

## SMARTENGINE INSTALLATION

The smartengine powers and communicates with smartgateways, smartsensors, and smart wall controllers to provide intelligent lighting control and building intelligence. The smartengine platform provides a sophisticated level of control, which significantly reduces energy consumption. Multiple smartengines can be clustered together to power and control up to 2000 smartengine endpoints with a smartdirector.

In regards to LED lighting, the smartengine provides AC to DC power conversion. Accepting either 200-250 VAC or 277 VAC input power, the smartengine converts it centrally to low-voltage constant current and distributes the power to fixtures via standard class 2, low-voltage cabling.



## ORDERING INFORMATION

PART NO.	DESCRIPTION
SENG-3-4834-250	Engine, 200-250 VAC
SENG-3-4834-277	Engine, 277 VAC
RackMount Brackets	Engine rack mount kit
WallMount-Tray-1G	Engine wall mount kit

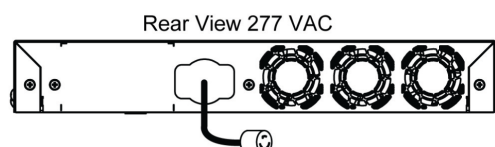
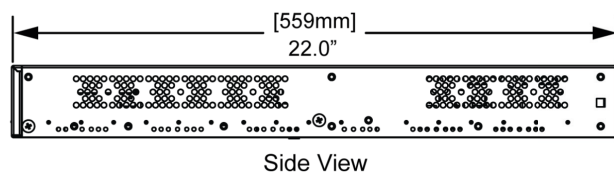
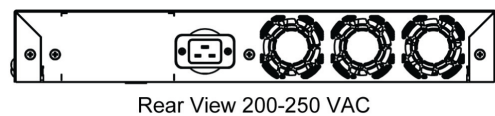
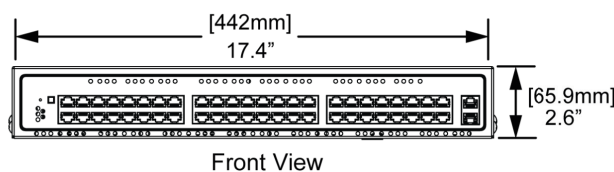

## SMARTENGINE INSTALLATION

### PREPARATION

1. Determine location for all fixtures and wall controllers
2. Determine location for all smartengines. The smartengine is a 1.5U rack mountable system and can be installed in a standard server rack using supplied rack-mounting L brackets, or to the wall with a wall mount smartkit.
3. Run low-voltage cable from smartengine location to each fixture location.
4. Run low-voltage cable from the smartengine location to each wall controller location.
5. Options for connector preparation:
  - If using the RJ45 connector, it can be wired as T568A (straight through) or T568B (crossover).
  - If using 18 AWG (1mm) wiring to connect to the smartengine, use a RJ45 smartinterface or Pivot Power RJ45 Assembly
6. Install light fixtures according to vendor's installation instructions.

### INSTALLATION

#### RACK MOUNT INSTRUCTIONS

1. Attach the two rack mount brackets to each side of the smartengine using 3 screws provided on each side as shown.
2. With power disconnected, install smartengine in a standard server rack, using mounting brackets (included). Ensure that air vents are not blocked and that the conditions support the ambient operation temperature of 32°F to 122°F (0°C to 50°C).
3. Connect the cables.

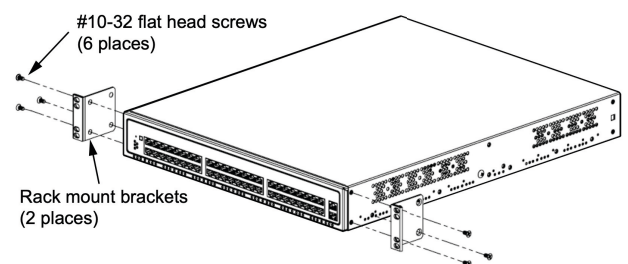

# SMARTENGINE INSTALLATION

## WALL MOUNT INSTRUCTIONS

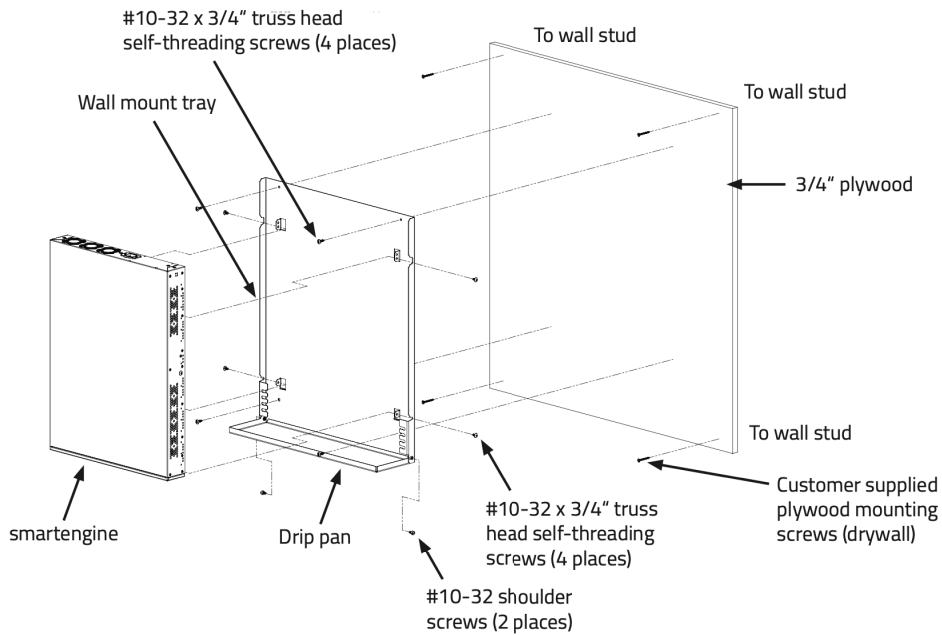

The smartengine can be installed flush against a wall using a smartengine wall mount kit as shown above. The wall mount kit contains two pieces, a wall mount tray and a drip pan. Use a 3/4" (19mm) plywood backing board (purchased locally). Plywood must be taller and wider than the wall mount tray and wide enough to span the wall studs.

4. Attach the 3/4" (19mm) plywood backing board to the wall studs using screws (not provided) that can hold at least 125 lbs (57kg). For a typical situation where the drywall is 5/8" (16mm) thick, a 2" (51mm) or longer drywall screw on each corner of the plywood is recommended.
5. Attach the wall mount tray to the plywood backing board using provided screws.
6. With power disconnected, attach the engine to the wall mount tray using provided screws. Mount the engine with the input power connection facing up and the port connectors facing down.
7. Attach the drip pan to the wall mount tray using the provided screws and rotate it to the position shown in the installed view of the wall mount assembly.
8. Connect the cables.

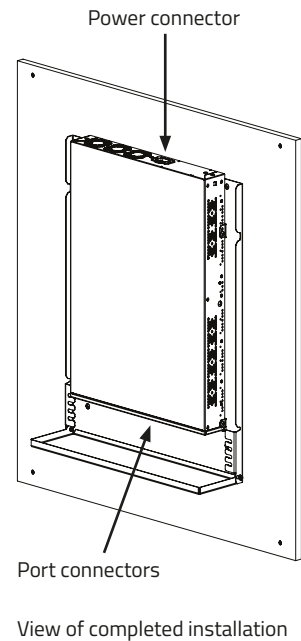

## SMARTENGINE INSTALLATION

### CABLING NOTE

The category cable should be punched down at the patch panels according to T568A or T568B standards, which are straight through or crossover arrangements.

1. Using a conventional method, connect the category cable wiring from the smartgateway to the punch downside of patch panel.
2. Use an RJ45 jumper cable (or patch cable) to connect the corresponding ports from patch panel.
3. Connect each smartengine to AC power and turn on AC power using the circuit breaker. Confirm that the smartengine power light comes on.
4. Connect all smartengines to the local network via Ethernet ports marked LAN.

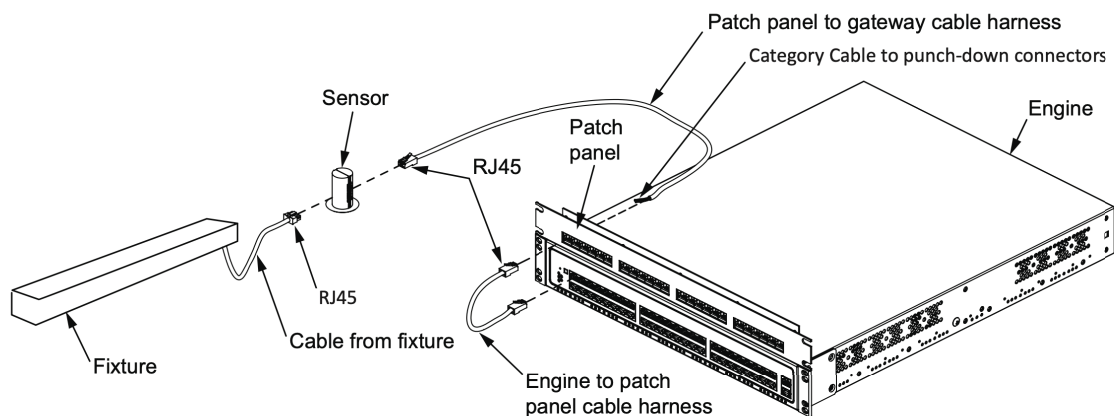

### SMARTENGINE POWER REQUIREMENTS

1. To ensure the smartengines operate continuously as designed, a dedicated branch circuit for the smartengines is recommended, preventing other loads on the same circuit from drawing too much current from the branch circuit. Provide the smartengine with a suitable disconnect in the input power distribution so that AC power is safely removed during servicing. The wiring must meet all NEC, state, and local electrical codes and needs to be installed by a qualified electrician.
2. smartengines are available as 200–250 VAC and 277 VAC power input versions.

## SMARTENGINE INSTALLATION

### 200 VAC-250 VAC VERSION

For the 200 VAC–250 VAC version, the smartengine requires a maximum 12A of current from the branch circuit to which it is connected when operating at full power. At minimum, a 15A branch circuit is required for a single smartengine, given the standard 80% de-rating.

- 200–220 VAC/12A, 50–60Hz
- 230 VAC–250 VAC/10A, 50–60Hz
- Max power consumption: 2,200W

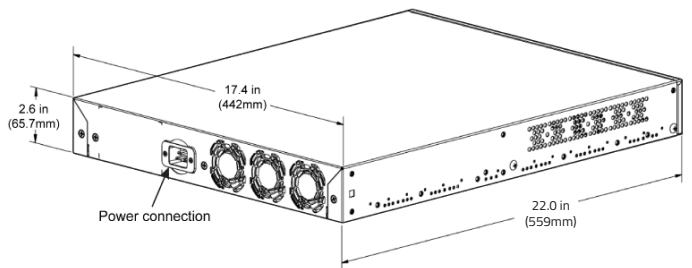

### NOTE

wtec does not furnish any pigtails, plugs, receptacles, conduit or flex cable.

### 277 VAC VERSION

For the 277 VAC version, the smartengine requires a maximum of 8A of current from the branch circuit to which it is connected when operating at full power. At a minimum, a 10A branch circuit is required for a single smartengine, given the standard 80% de-rating. The socket-outlet shall be installed near the equipment and shall be easily accessible.

- AC input: 277 VAC/8A, 50–60Hz
- Max power consumption: 2,200W

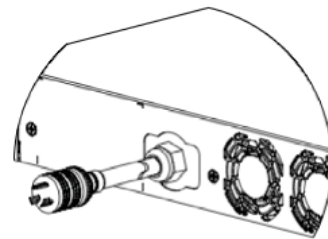

## SMARTENGINE INSTALLATION

### SMARTENGINE LED INDICATORS

The smartengine has a series of LEDs on the front panel to communicate the system’s status. These LEDs provide information on the smartengine’s operation and the status of port communication.

SMARTENGINE PORT LED INDICATORS



POWER LED INDICATOR

ETHERNET STATUS INDICATORS

#### POWER INDICATOR STATUS

POWER LED INDICATOR	ENGINE STATUS
Off	No power is delivered to the smartengine.
Blinking green	The engine is booting. Manager software is not yet running.
Solid green	The engine is on and functioning normally.
Solid amber	The engine is experiencing a problem. Call smartengine support.

#### POWER INDICATOR STATUS

Each port on the smartengine has a multi-color LED to communicate status for that port. After a period of inactivity, the LEDs are turned off to save energy. To activate the lights, press the **SHOW STATUS** button on the smartengine faceplate.

ENGINE PORT LED INDICATOR STATUS	PORT STATUS
Off	No device connection is detected on the port.
Solid green	The engine recognizes the device connection.
Blinking green	The engine is upgrading the firmware of a gateway.
Solid amber	The engine is in the process of discovering a fixture. Alternately, an error has occurred after discovery.

#### ETHERNET INDICATOR STATUS

ETHERNET INDICATOR STATUS	ETHERNET STATUS
Off	An Ethernet connection is not detected on this port.
Blinking green	The engine recognized the Ethernet connection.

## SMARTENGINE INSTALLATION

### IMPORTANT NOTES AND RECOMMENDATIONS

- For installations in Canada, no un-insulated live parts in the output from the smartengine shall be readily accessible, as defined by the Canadian Electrical Code (CES). Accessibility shall be determined using the risk of shock accessibility criteria such as use of the finger probe from the CSA standard(s) cited for the category associated with the c-UL Mark.
- Access to such parts should also be considered when removing panels that do not require the use of tools when removed. Insulated parts, such as wire or cabling with outer insulation or jacket that are certified and carry a sufficient voltage rating (>60V) are permitted to be accessible to contact.
- If a fixture requires more than one channel for power, use additional wiring (see each fixture's specification for requirements). Note that all additional channels for a 2- or 3-channel fixture must be connected to the same smartengine. Wiring for an individual fixture cannot be spread across multiple smartengines.
- It is recommended that the fixtures in a single space be interleaved across smartengine. This provides another level of redundancy — in the event of an electrical failure affecting a smartengine, only a portion of the lights in a room would turn off.
- 18 AWG (1mm) cable installations will be wired as with category cable, except that each 18AWG cable pair will be terminated with a RJ45- 18AWG smartterminator. These smartterminators will allow the 18AWG pair to be connected to the RJ45 jack with no other modifications required. Multi-pair 18AWG can be used with multiple RJ45- 18AWG smartterminators attached.
- The smartengine, smartdirector, smartsensors, smartgateways and wall smartswitches are designed for commercial use only and are not for residential use.

## SMARTENGINE INSTALLATION

The following section defines the limits to help avoid IT equipment damage and/or failure from particulates and gaseous contamination. If the levels of particulates or gaseous pollution are beyond the specified limits and cause equipment damage or failure, you may need to rectify the environmental conditions. Remediation of environmental conditions is the responsibility of the customer.

### SPECIFICATIONS

Data center air filtration as defined by ISO Class 8 per ISO 14644-1 with a 95% upper confidence limit.

**Note:** Applies to data center environment only. Air filtration requirements do not apply to IT equipment designed to be used outside a data center, in environments such as an office or factory floor.

**Note:** Air entering the data center must have MERV11 or MERV13 filtration. Air must be free of conductive dust, zinc whiskers, or other conductive particles.

**Note:** Applies to data center and non-data center environments.

- Air must be free of corrosive dust.
- Residual dust present in the air must have a deliquescent point less than 60% relative humidity.

Details:

<300 Å/month per Class G1 as defined by ANSI/ISA71.04-1985.

<200 Å/month as defined by AHSRAE TC9.9.

**NOTE:** Maximum corrosive contaminant levels measured at ≤50% relative humidity.

### IMPORTANT

The smartengine, smartdirector, smartgateways, smartsensors, and smartswitches are designed for commercial use only and are not for residential use.

---

#### REGULATORY COMPLIANCE/CERTIFICATIONS

Agency	Classification
RoHS 2011/65/EU	Compliant

