

SSEN-2-W INSTALLATION GUIDE

The SSEN-2-W works with smartengine-ready 3rd party LED fixture, collects data on light levels, temperature and motion, generates and detects beacons in iBeacon format. The smartsensor is easily installed in a ceiling tile or junction box near the fixture or a fixture itself and accepts standard category 5e, 6 or 6a cable via RJ45 connectors. The smartsensor can also be connected to an electrical light switch with 20 AWG (1mm) wiring via snap-in connectors to enable manual lighting control. The LED smartsensor SSEN-2-W must be used with software version 5.5 or newer.



ORDERING INFORMATION

PART NO.	DESCRIPTION
SSEN-2-W-c-GNEW1150	smartsensor with beacon, 150-349 mA
SSEN-2-W-c-GNEW1350	smartsensor with beacon, 350-500 mA
SSEN-2-W-c-GNEW1500	smartsensor with beacon, 500-700 mA
SSEN-2-W-c-SENSOR00	smartsensor with beacon, sensor only

c = W for white and E for black

SMARTSENSOR COMPONENTS AND DIMENSIONS

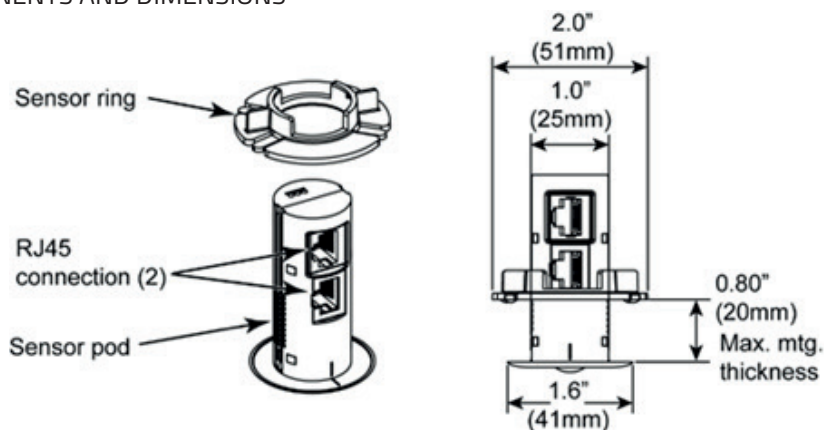

SSEN-2-W INSTALLATION GUIDE

IMPORTANT

- Be sure the smartsensor is clear of any other equipment above the tile.
- The plastic smartsensor cap should be tight against the ceiling tile.
- The smartsensor may be rotated inside the ceiling tile hole, but it must remain perpendicular to the tile.
- It is recommended to not place smartsensor near heating vents, AC units, or any other electrically dynamic system.
- The smartsensors have been tested by UL to UL2043 which ensure slow smoke-emitting characteristics and suitable fire resistance for equipment that may be installed in environmental air-handling spaces, as described in Article 300.22(c) of the NEC (2008).
- When the product is installed in air-handling spaces, such as above some suspended ceilings, the cabling employed should be suitable under NEC (2008) Article 800.154 and marked accordingly for use in plenums and air-handling spaces with regard to smoke propagation, such as CMP. The products and wiring should be installed in accordance with all applicable local regulations and practices.

PREPARATION

1. For a lay-in light fixture (2' x 2', 2' x 4', or 600mm x 600mm), smartsensors should be placed in the ceiling tile adjacent to the fixture. For downlights, smartsensors can be placed in the same ceiling tile. Fixtures come with attached RJ45 plugs and wires. The wire length may limit the distance of the smartsensor from the fixture.

2. smartsensors should be placed close to the fixture, preferably within 12" (305mm) in order to obtain accurate light level readings and enact daylight harvesting accurately. Determine where in the ceiling tile the smartsensor needs to be installed; refer to the diagram (Figure 1) on page 3.

NOTE

The motion coverage pattern diagram of the smartsensor is shown below. The diagram illustrates the expected motion sensing coverage for each smartsensor installed at a ceiling height of 10 feet (3m).

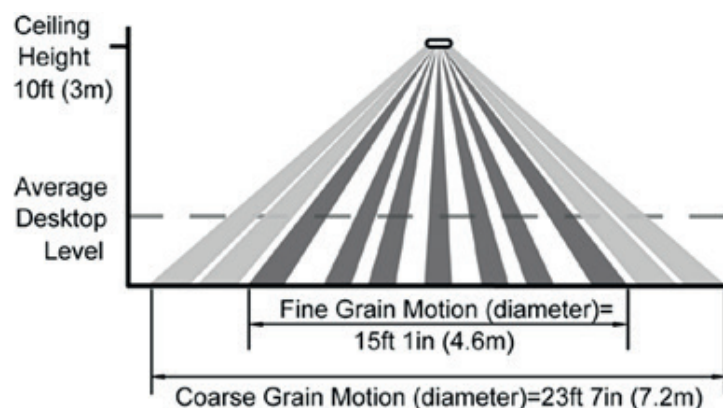

Fine and Coarse Grain Detection Ranges at Ceiling Height of 10 ft. (3m)

SSEN-2-W INSTALLATION GUIDE

INSTALLATION

1. Within 12" (305mm) of the fixture, drill a 1" (25mm) diameter hole in the ceiling tile.
2. Carefully push the smartsensor through the ceiling tile.
3. Twist and lock the adjusting height sensor ring to tighten the smartsensor against the tile.
4. Connect the fixture to the smartsensor by way of the white RJ45 jack.
5. Connect the black RJ45 jack from the smartsensor to the smartengine using category cable.

FIGURE 1

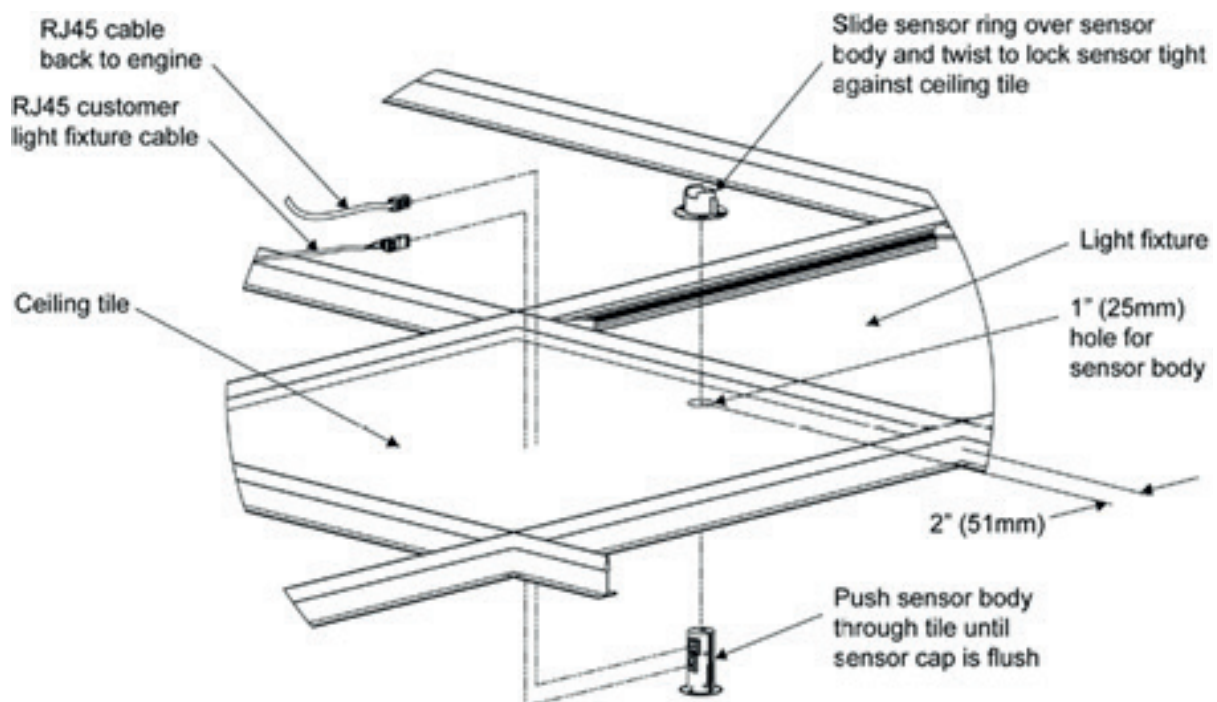

SSEN-2-W INSTALLATION GUIDE

OPTIONAL STEP - CONNECT SMARTSENSOR TO LIGHT SWITCH

NOTE

The smartsensor may be connected to a single-pole, single-throw (SPST or SPDT) light switch using 20 AWG (1mm) wire. When connected to an individual smartsensor in a designated room, the switch will control all the light fixtures in that room manually.

IMPORTANT

This is not an option for the smartdimmer or scene control wall smartswitch.

PREPARATION

1. Determine location for the wall switch and associated smartsensor.
2. Run two (SPST) or three (SPDT) low-voltage 20 AWG (1mm) cables from smartsensor to wall switch location.

Note: It is recommended to use jacketed 20/2 or 20/3 solid core bell wire for this application.

3. Strip 1/4" (6mm) of insulation from the end.
4. Cut or use an existing standard-sized wall plate opening for a NEMA standard, OTS electrical switch box with an open back.

INSTALLATION

1. With the light switch in the ON position, run 20 AWG (1mm) cable from the light switch to Port C on the smartsensor and the remaining end to either Port A or Port B for SPST and all three for SPDT.
2. Install the faceplate on the switch.

SSEN-2-W INSTALLATION GUIDE

COMPLIANCE

Important FCC Compliance Information for Device Operation: This device complies with part 15 of the FCC Rules. Operation is subject to the following two conditions: (1) This device may not cause harmful interference, and (2) this device must accept any interference received, including interference that may cause undesired operation. Changes or modifications not expressly approved by wtec GmbH could void the user's authority to operate the equipment.

Compliance with ISED's Licence-Exempt RSS: This device contains licence-exempt transmitter(s)/receiver(s) that comply with Innovation, Science and Economic Development Canada's licence-exempt RSS(s). Operation is subject to the following two conditions: (1) this device may not cause interference, and (2) this device must accept any interference, including interference that may cause undesired operation of the device.

Cet appareil contient un ou des émetteurs/récepteurs exempts de licence conformes aux RSS exempts de licence d'Innovation, Sciences et Développement économique Canada. Son fonctionnement est soumis aux deux conditions suivantes: (1) cet appareil ne doit pas causer d'interférences et (2) cet appareil doit accepter toute interférence, y compris les interférences susceptibles de provoquer un fonctionnement indésirable de l'appareil.

Registration number

FCCC ID 2BAE8-SSEN2 | IC 30107-SSEN2