

## Stylish Domes and Room in Room Structures for events, congresses and offices



Minimum assembly  
and disassembly time



Rooms for 1 to 1000+ people



Optimal acoustics  
& sound insulation



No fan noise



Sustainable and circular

# SHELL DOME



## General

This striking Shell Dome is an inflatable presentation booth and extremely suitable for, for example, marketing events, exhibition stands, workshops or presentations. The large front opening provides a broad view, so that a presentation can be held or a product can be displayed in an optimal way.



# Measurements

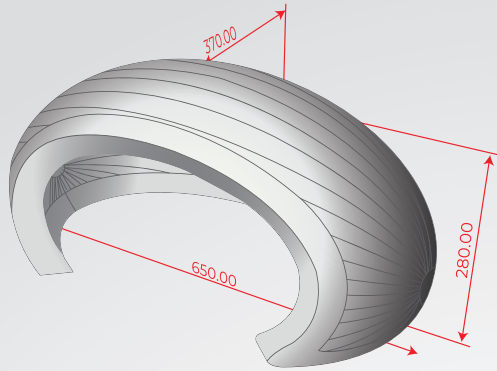

PRESPECTIVE

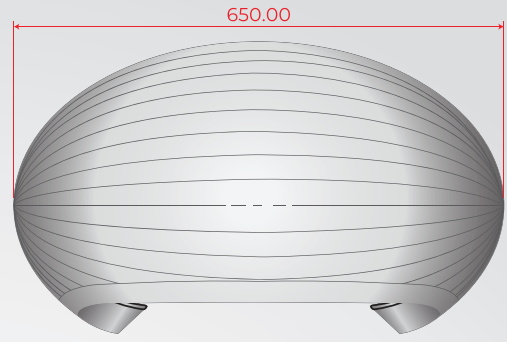

TOP



FRONT

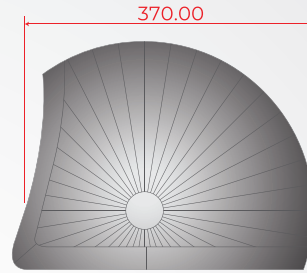

RIGHT



Length  
(outer / inner)

6.5 m  
5.5 m

Width  
(outer / inner)

3.7 m  
3.2 m

Height  
(outer / inner)

2.8 m  
2.1 m

Surface  
(inner)

12m<sup>2</sup>

Max chairs

8 - 12

Color

white

LED

RGB bars  
of 1m

Weight

20 kg

Power

220v  
250w no LED  
500w With LED

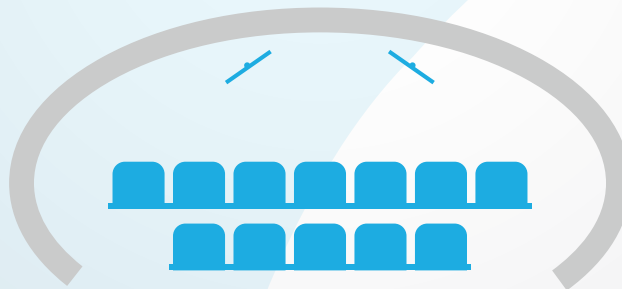

Max Seating  
~12 chairs

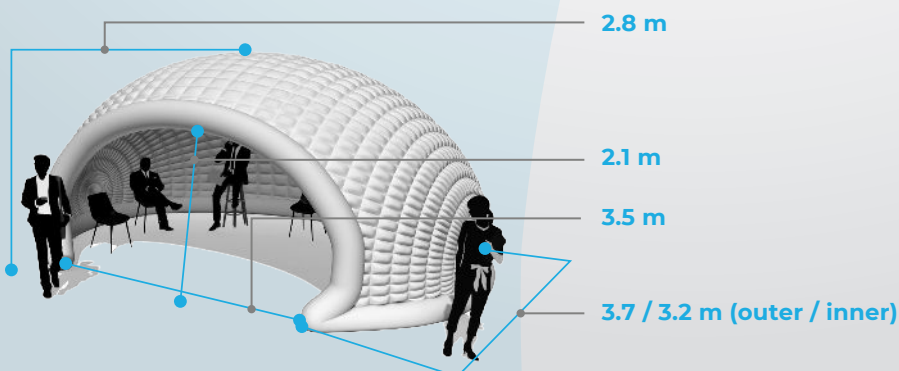

SHELL  
DOME

# Product Enhancement

## ACOUSTICS AND QUIET AIRFLOW

This Shell is optimized for acoustic properties, making them ideal for workshops and presentations or acoustic partitions, for example. In addition, this structure is equipped with an isolated blower system that is not audible.

## LED LIGHTING

This structure can be illuminated in any color using LED modules, creating a unique ambiance. This can be set both statically and dynamically.

## BRANDING

On request, this structure can be branded with your own branding, for example by theme colors, projection of logos or texts, or by means of TV screens or banners.

## FIRE SAFETY CERTIFICATES

All our structures have the most important fire safety certificates such as German B1, France M1 and American NFPA 701

## SUSTAINABILITY AND CIRCULARITY

With QuickSpace products, you don't create waste at your event. Our products are cleaned in an environmentally friendly way after use, making them new-worthy at every event. At the end of life, our products are processed into other products such as storage bags, contributing to a circular economy.

## QUICK INSTALLATION AND DISMANTLING

One of the benefits of QuickSpace products is the quick installation and dismantling. Hence, it is possible to install the structures at your convenient times, saving you costs and time. Our experienced teams will take care of the installation, disassembly and, if necessary, design of your event.

## LOCAL HEATING / ENERGY SAVING

Given the closed roof of this structure, it is possible to heat the structure inside. This gives the advantage that the space outside the structure does not necessarily need to be heated, such as a large hall for example. This allows to save high energy costs.



### Phone:

+31 6 41 67 57 07  
+31 6 12 98 62 31

### E-mail:

info@quickspace.eu

### QuickSpace B.V.

Lonnekerweg 298  
7532 RD Enschede  
Nederland



facebook.com/quickspace\_domes



instagram.com/quickspace\_eu

### Contact

### Phone:

+49 176 55071328

### E-mail:

info@quickspace.de

### QuickSpace Zeltsysteme GmbH

Buterlandstr. 89  
D-48599 Gronau  
Deutschland  
USt-ID: DE 322458558

quickspace.eu