

Product Specification Sheet

SONIC 100
CENTRIFUGAL BLOWER
 NEMA / BALDOR MOTORS
 60 HZ, 230/460V TEFC, 3600 RPM

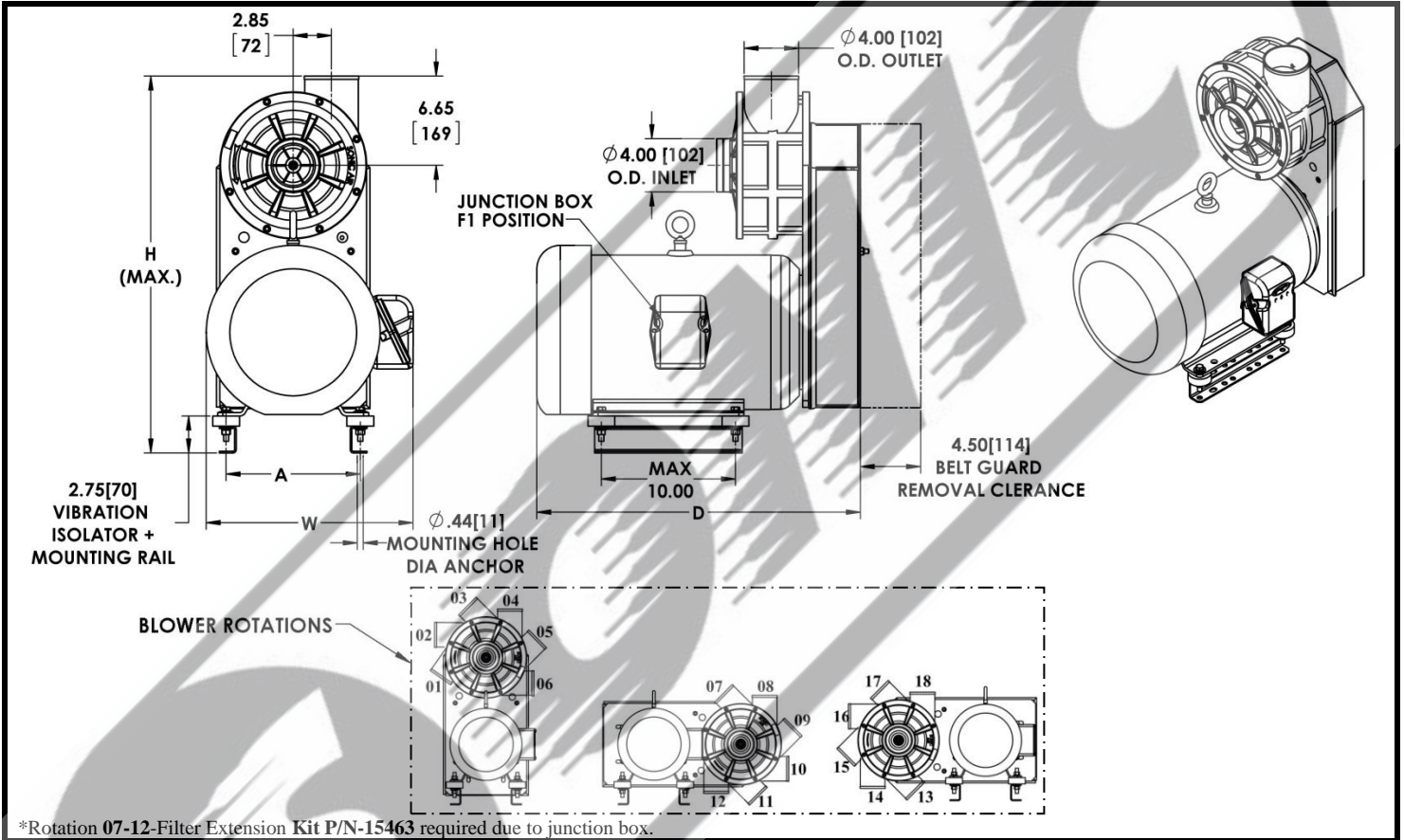

*Rotation 07-12-Filter Extension Kit P/N-15463 required due to junction box.

Dimensions in Inches, [] are in millimeters

Model / Description	Sonic 100 / Air Cooled		Sonic 100C / Water Cooled	
Assembly Part Number	Call Sonic		Call Sonic	
Output Flow Rate	100 cfm to 1,000 cfm (170 m ³ /hr to 1,700 m ³ /hr)		100 cfm to 1,000 cfm (170 m ³ /hr to 1,700 m ³ /hr)	
Ambient Temperature	32°F to 105°F (0°C to 40°C)		32°F to 105°F (0°C to 40°C)	
Inlet Air Temperature Range	32°F to 125°F (0°C to 52°C)		125°F to 400°F (52°C to 205°C)	
Motors / Frames	15 Hp/ 215	20 Hp/ 256	15 Hp/ 215	20 Hp/ 256
Width (W)	13.00 in [330]	15.42 in [392]	13.00 in [330]	15.42 in [392]
Depth (D)	20.86 in [530]	24.10 in [612]	20.86 in [530]	24.10 in [612]
Height (H)	28.15 in [715]	29.10 in [739]	28.15 in [715]	29.10 in [739]
Mounting Pattern (A)	8.50 in [216]	10.00 in [254]	8.50 in [216]	10.00 in [254]
Approximate Weight	291 lbs (132 Kg)	315 lbs (143 Kg)	291 lbs (132 Kg)	315 lbs (143 Kg)