

- 3.0 KHZ BROADBAND PROJECTOR
- HIGH POWER
- DIRECTIONAL BEAM PATTERN
- HIGH PERFORMANCE
- LONG RANGE TRANSMISSION
- LOW COST

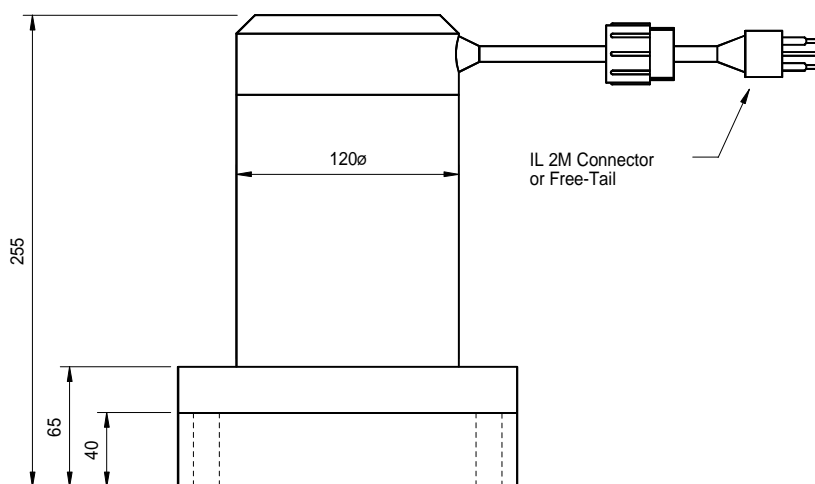
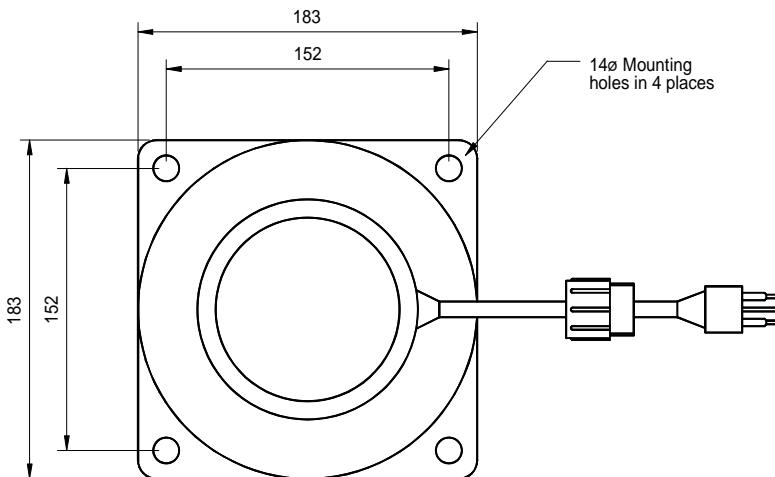

All dimensions in mm

The T335 is a single piston transducer offering a high power, broad band performance at an affordable price.

With a nominal operating frequency range from 2 kHz to 8 kHz transducers can be configured to form half lambda spaced arrays.

The robust design is tolerant of both dynamic and static pressure making it particularly suitable for Military applications.

The T335 is fitted with a standard internal tuning network to achieve the transmit response illustrated overleaf.

Alternative tuning arrangements providing different responses can be fitted upon request. The standard connector is an in-line Subconn type IL2M, alternative connectors are available.

Technical Specification

Resonant Frequency	3.0 kHz
Useful Frequency Band	2 kHz to 8 kHz
Beam Pattern	90 Degrees
Nominal Impedance	220 Ohms
Input Power Max	750 Watts
Receive Sensitivity	See Graph
Transmit Sensitivity	See Graph
Operating Depth	600 Metres
Cable / Connector Type	Sub-Conn IL2 M
Cable Length	200mm Standard
Operating Temperature	-5 to +40 °C
Storage Temperature	-40 to +80 °C

Receive Graph

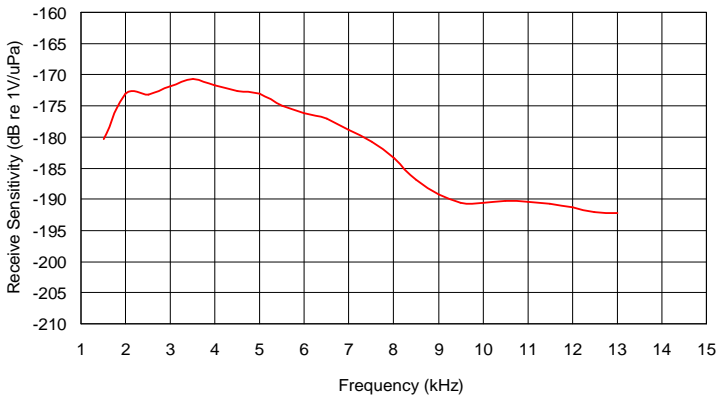

Admittance Plot

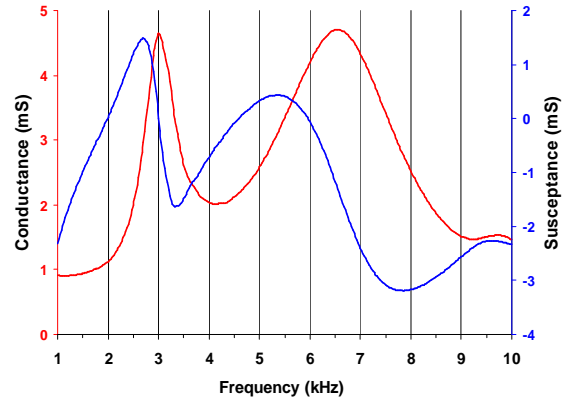

Transmit Graph

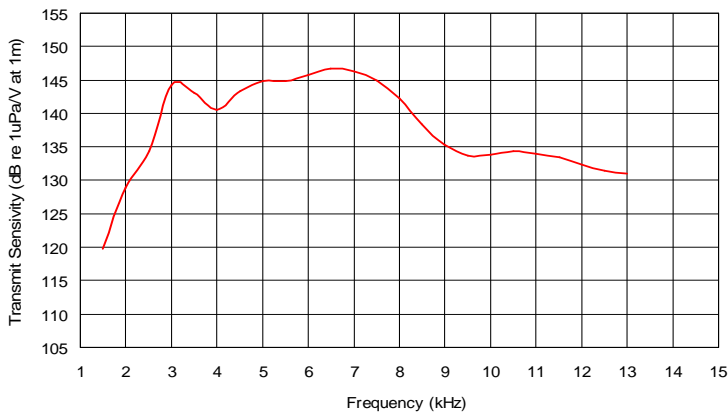

Beam Pattern at 3 kHz Vertical

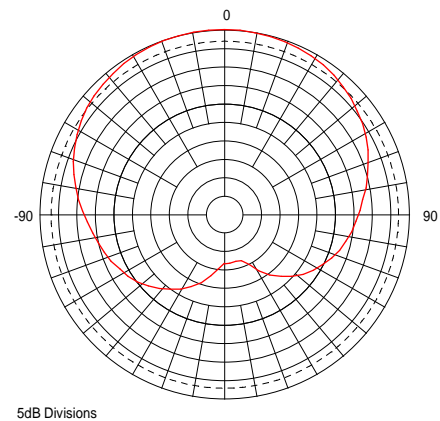

Data illustrated is taken from actual in-water measurements