

# X-650

Sprue Picker  
IMM RANGE 30 – 180 Ton



X-650	Metric		Standard	
<b>IMM Range</b>	kN	267 - 1601	30 - 180	US Tons
<b>Max Payload</b>	kg	2	4.41	lbs
<b>Stroke Vertical</b>	mm	650	25.59	in
<b>Stroke Crosswise</b>	mm	120	4.72	in
<b>Swing Angle</b>	Degree (°)	50-90	50-90	Degree (°)
<b>Gripper Angle</b>	Degree (°)	90	90	Degree (°)
<b>Drive System</b>	Drive	Pneumatic	Pneumatic	Drive
<b>Working Air Pressure</b>	kg/cm <sup>2</sup>	5 ~ 8	71.12 ~ 113.80	psi
<b>Air Consumption</b>	NL/cycle	7.6	256.99	Fluid oz
<b>Power Consumption</b>	KVA	0.2	0.2	KVA
<b>Power Supply</b>	Voltage/Phase/Hz	120 or 240/1P/60Hz	120 or 240/1P/60Hz	Voltage/Phase/Hz
<b>Weight</b>	kg	43	94.8	lbs



Rev: 1 - 03312021

508-792-4305 | [absoluterobot.com](http://absoluterobot.com)

# X-650

Sprue Picker  
IMM RANGE 30 – 180 Ton



## STANDARD FEATURES:

- 1 Vacuum Circuit with Confirmation
- 1 Gripper Circuit
- 4 Spare Input/Output signals
- Easy changeover between operator and non-operator part drop
- Dual rail strip axis allows for fast and stable movement with low vibration
- Linear vertical rails with Bosch Rexroth bearings
- Sprue grip with unique pressure differential detection switch, which eliminates verification switch adjustment
- Two-way solenoid valve on the vertical arm allows for safe (not spring loaded) emergency stop
- Easy to follow preloaded program templates
- Internal transformer allows for 120V/240V (1P) power



## OPTIONS:

- Riser/Adapter Plate
- Dual-Arm
- Extended Pendant Cable
- Custom End-Of-Arm-Tooling
- Downstream Equipment (Guarding, Conveyors, Labeling, Packaging, etc.)



Rev: 1 - 03312021

508-792-4305 | [absoluterobot.com](http://absoluterobot.com)

# X-650

Sprue Picker  
IMM RANGE 30 – 180 Ton



Model	A	B	C	D	E	F	G	H	I	J	K	L
X-650	1400	1330	160	130	417	550	260	178	181	55	390	650

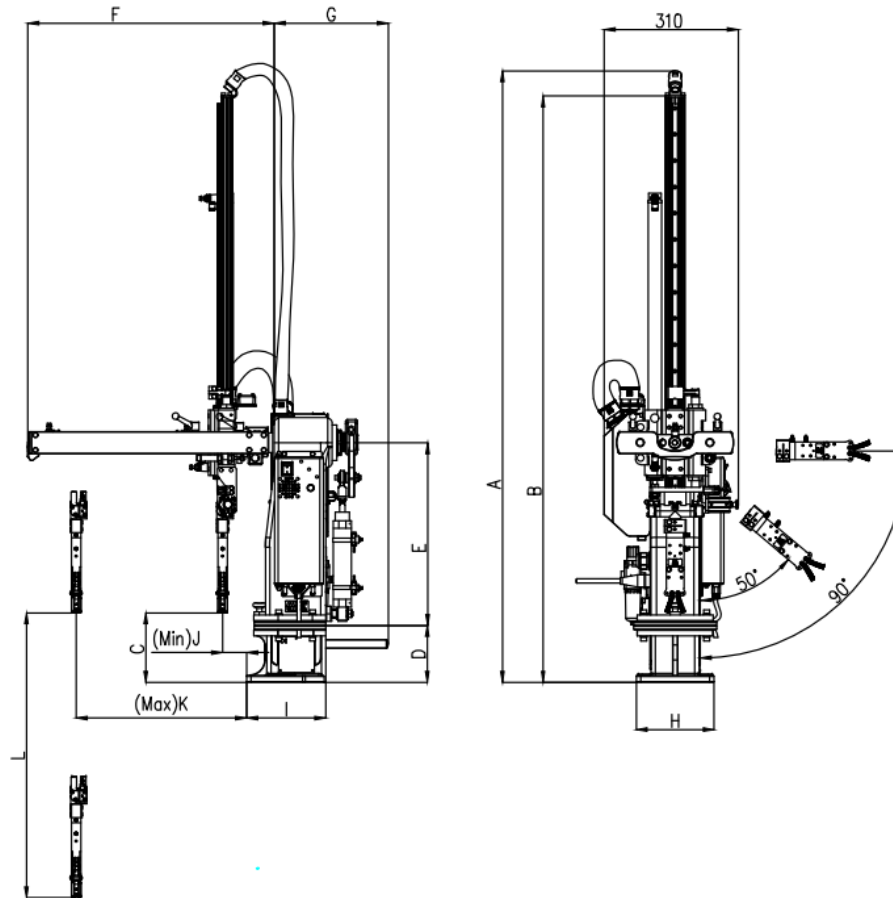

Specifications are subject to change