

VC-12MX-M/C 180 VC-25MX-M/C 72 VC-25MX-M/C 81 D

High Speed & High Resolution CMOS Digital Camera
with CoaXPress Interface



The VC-12MX-180, VC-25MX-72 and VC-25MX-81 D, the latest members of industrial proven VC series, are based on the latest CMOS global shutter imagers. The VC-12MX-180 features 12 megapixel resolution with frame rates of up to 181 fps, the VC-25MX-72 features 25 megapixel resolution with frame rates of up to 72 fps and the VC-25MX-81 D features 25 megapixel resolution with frame rates of up to 81 fps. These combinations of resolution, frame rate, and global shutter set a new standard for Industrial, Scientific, and Surveillance digital imaging applications. Customers in the industrial market can take advantage of common coax cabling to transmit images at rates and distance above and beyond previous standards. With these cameras, image data can be transmitted at up to 6.25 Gbps using a single coaxial cable and up to 25 Gbps using four cables. These high speed and high resolution models are ideal for wide range of demanding applications including PCB and semiconductor inspections.

VC-12MX-180 / VC-25MX-72 / VC-25MX-81 D

High Speed & High Resolution CMOS Digital Camera with CoaXPress Interface

Main Features

- 12 & 25 Megapixel Resolutions
 - High-Speed Progressive Scan CMOS Imager
 - Global Shutter CMOS Technology
 - CoaXPress Interface up to 181 fps at 25 Gbps using 4 CH (VC-12MX-180)
 - Flat Field Correction
 - DSNU and PRNU Correction (VC-25MX-72/VC-25MX-81 D)
 - Low Noise with Optimized Heat Treatment
- PCB Inspection
 - Semiconductor Inspection
 - 3D Inspection
 - High-end Surveillance

Applications

Specifications

Model	VC-12MX-M/C 180	VC-25MX-M/C 72	VC-25MX-M/C 81 D	
Resolution (H × V)	4096 × 3072	5120 × 5120	5120 × 5120	
Sensor	CMOSIS CMV 12000	On Semi. VITA-25K	On Semi. PYTHON-25K	
Sensor Size	22.5 mm × 16.9 mm (Diagonal: 28.1 mm)	23.04 mm × 23.04 mm (Optical Format: 35 mm)	23.04 mm × 23.04 mm (Diagonal: 32.6 mm)	
Sensor Type	High Speed CMOS Image Sensor			
Pixel Size	5.5 μm × 5.5 μm	4.5 μm × 4.5 μm	4.5 μm × 4.5 μm	
Interface	CoaXPress			
Max. Frame Rate	1 CH: 46 fps @ 6.25 Gbps	1 CH: N/A	1 CH: N/A	
	2 CH: 92 fps @ 6.25 Gbps	2 CH: 46 fps @ 6.25 Gbps	2 CH: 44 fps @ 6.25 Gbps	
	4 CH: 181 fps @ 6.25 Gbps	4 CH: 72 fps @ 6.25 Gbps	4 CH: 81 fps @ 6.25 Gbps	
Exposure Time† (1 μs step)	43 μs – 60 s	1 μs – 60 s		
Partial Scan (Max. Speed)	15151 fps at 4 Lines	7692 fps at 4 Lines (H: 256)	10989 fps at 4 Lines (H: 256)	
Pixel Data Format	8 bit	8 bit, 10 bit	8 bit	
Electronic Shutter	Global Shutter			
Gain Control	1× ~ 4×			
Black Level Control	0 – 16 LSB at 8 bit	0 – 16 LSB at 8 bit 0 – 64 LSB at 10 bit	0 – 16 LSB at 8 bit	
Trigger Synchronization	Free-Run, Timed, Trigger Width			
Dynamic Range	54 dB			
Dimension / Weight	80 mm × 80 mm × 102 mm, 610 g (F-mount)			
Temperature	Operating: -5°C ~ 40°C, Storage: -40°C ~ 70°C			
Lens Mount	F-mount			
Power	External	10 ~ 38 V DC, Typ. 12 W	10 ~ 38 V DC, Typ. 10.5 W	10 ~ 38 V DC, Typ. 12 W
	PoCXP	24 V DC, Minimum of two PoCXP cables required		
Compliance	CE, FCC, KC			
API SDK	Vieworks Imaging Solution 7.X			

† The minimum actual exposure time varies depending on the camera model.

VC-12MX-180 / VC-25MX-72 / VC-25MX-81 D

High Speed & High Resolution CMOS Digital Camera with CoaXPress Interface

Spectral Response

VC-12MX-M/C 180

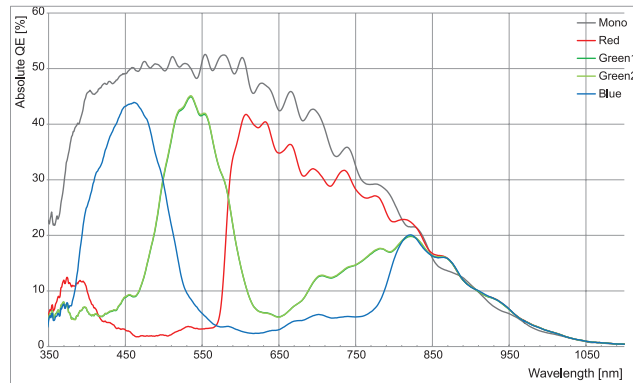

VC-25MX-M/C 72

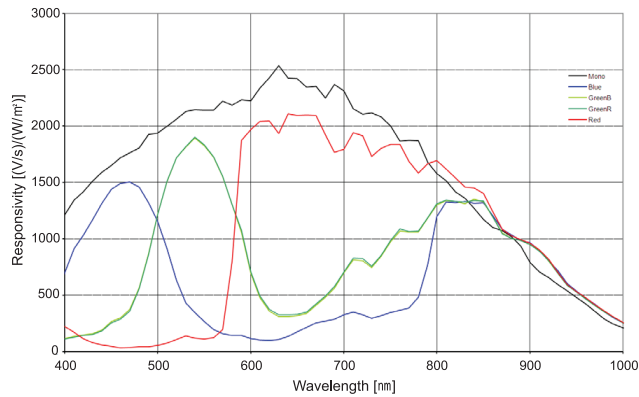

VC-25MX-M/C 81 D

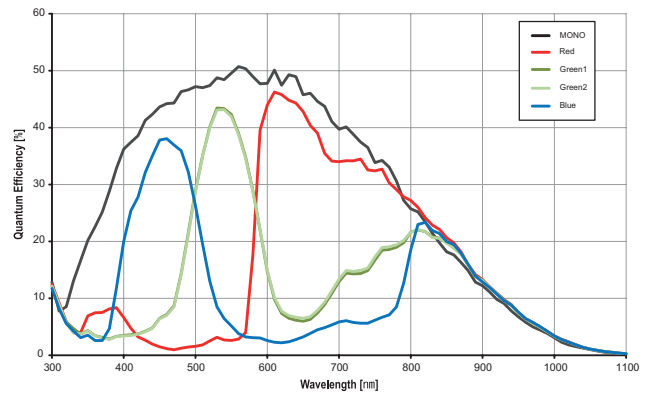

Ordering Scheme

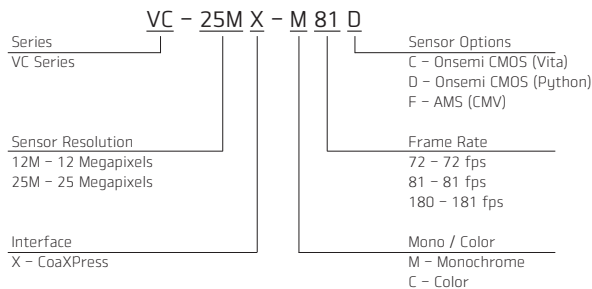

Connector Specification

Power



1, 2, 3: +12V DC
4, 5, 6: GND
(HR10A-7R-6PB)

Control



1: Trigger IN+ 2: Trigger IN-
3: DC Ground 4: Strobe OUT+
(HR10A-7R-4S)

Data Transfer/Communications

BNC



CH1



CH2



CH3



CH4

DIN



CH1 CH2 CH3 CH4

CH1: Master Connection (75 Ω, DIN 1.0/2.3)

Connectors on camera body

VC-12MX-180 / VC-25MX-72 / VC-25MX-81 D

High Speed & High Resolution CMOS Digital Camera with CoaXPress Interface

Mechanical Dimensions

Unit: mm

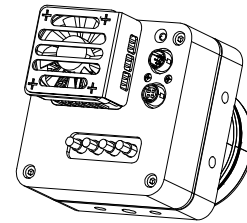
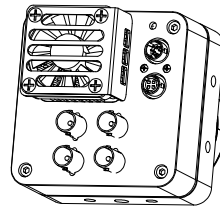
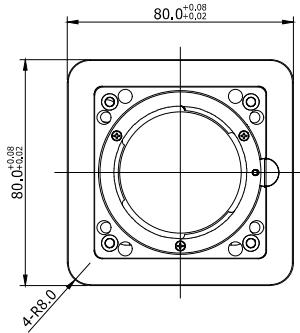

BNC-Type

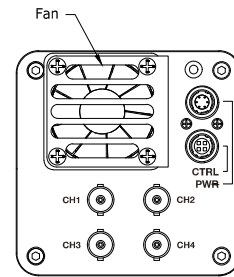
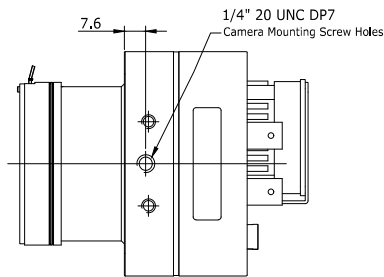
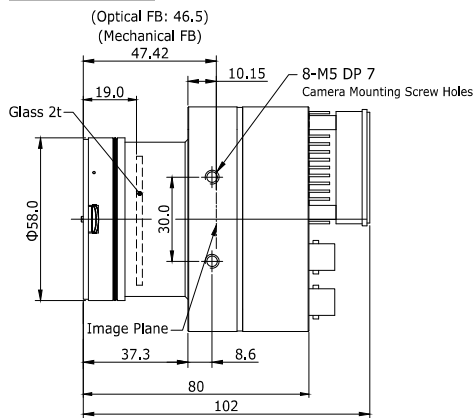

DIN-Type

