

ICC-ES Evaluation Report

ESR-3031

Reissued December 2023

This report also contains:

- CBC Supplement

Subject to renewal December 2025

- LABC Supplement

ICC-ES Evaluation Reports are not to be construed as representing aesthetics or any other attributes not specifically addressed, nor are they to be construed as an endorsement of the subject of the report or a recommendation for its use. There is no warranty by ICC Evaluation Service, LLC, express or implied, as to any finding or other matter in this report, or as to any product covered by the report.

Copyright © 2023 ICC Evaluation Service, LLC. All rights reserved.

<p>DIVISION: 05 00 00— METALS</p> <p>Section: 05 12 00— Structural Steel Framing</p>	<p>REPORT HOLDER: CAST CONNEX CORPORATION</p>	<p>EVALUATION SUBJECT: CAST CONNEX® HIGH- STRENGTH CONNECTORS™</p>	
--	--	---	---

1.0 EVALUATION SCOPE

Compliance with the following codes:

- 2018, 2015, 2012 and 2009 [International Building Code® \(IBC\)](#)

For evaluation for compliance with codes adopted by Los Angeles Department of Building and Safety (LADBS), see [ESR-3031 LABC Supplement](#).

Property evaluated:

- Structural

2.0 USES

Cast ConneX® High-Strength Connectors™ are used as steel brace-to-gusset plate connections in seismic-resistant steel concentrically braced frame construction. The connectors are also used in non-seismic structural applications as connectors for structural steel elements loaded predominantly in tension and/or compression.

3.0 DESCRIPTION

3.1 General:

Cast ConneX® High-Strength Connectors™ provide brace-to-gusset plate connections for use in Special Steel Concentrically Braced Frame (SCBF) and Ordinary Steel Concentrically Braced Frame (OCBF) systems as defined in the AISC Seismic Provisions. The connectors are configured as a single-piece element with two parallel flat plates at one end, which transition to a single circular shape at the opposite end. The circular end includes a preparation which forms a 60-degree groove angle between the wall of the round HSS or pipe when mated to the connector. Five connector sizes are available, which are coordinated to fit the outer diameter of standard round hollow structural section (HSS) or pipe sections used to construct the brace:

Model	HSS and Pipe outside diameter
HSC-102	4-inch (102 mm)
HSC-141	5 ⁹ / ₁₆ -inch (141 mm)
HSC-168	6 ⁵ / ₈ -inch (168 mm)
HSC-219	8 ⁵ / ₈ -inch (219 mm)
HSC-273	10 ³ / ₄ -inch (273 mm)
HSC-12.75	12 ³ / ₄ -inch (324 mm)
HSC-14.00	14-inch (356 mm)

The connectors must be shop-welded by a registered and approved fabricator to round HSS or pipe brace elements using complete joint penetration (CJP) groove welds; and the resulting brace-connector assembly

must be field-bolted or field-welded to single gusset plates connected to the beam-column intersections of a structural steel frame at each end of the brace-connector assembly. The flat plates of the connectors must be prepared with holes by the registered and approved fabricator to allow for bolted connections. Illustrative details are provided in [Figures 1, 2, and 3](#).

3.2 Materials:

3.2.1 Cast ConneX[®] High-Strength Connectors[™]: The proprietary connectors are produced by Cast ConneX Corporation from cast steel complying with ASTM A958 Grade SC 8620 Class 80/50, including supplementary requirements set forth in Appendix A of ANSI/AISC 358 (-16, -10 and -05) and additional requirements in the approved quality documentation. The minimum strength properties are $F_y = 50$ ksi (345 MPa) and $F_u = 80$ ksi (552 MPa).

3.2.2 Structural Shapes: Structural steel shapes that must be used in conjunction with Cast ConneX[®] High-Strength Connectors[™] include round hollow structural sections (HSS) conforming to ASTM A500 Grade B or C, ASTM A501 Grade A or B, and ASTM A1085 Grade A; and pipe conforming to ASTM A53 Grade B. The HSS and pipe must also comply with requirements in Sections F1.5 or F2.5 of ANSI/AISC 341 (-16 and -10), and Sections 14.2 or Section 13.2 of ANSI/AISC 341-05 for OCBFs or SCBFs, respectively, as applicable.

3.2.3 Welds: The welded joint between a Cast ConneX[®] High-Strength Connector[™] and the connected HSS or pipe brace member must provide complete joint penetration (CJP). When the brace-connector assembly is to be field-welded to the gusset plate rather than field-bolted, the connection between a Cast ConneX[®] High-Strength Connector[™] and the gusset plate must be made using fillet welds. All welded joints must comply with the requirements stipulated in ANSI/AISC 360 (-16, -10 and -05) and ANSI/AWS D1.1 (-15, -10 and -04). For structures located in Seismic Design Category D, E, or F, welded joints must additionally comply with requirements stipulated in ANSI/AISC 341 (-16, -10 and -05) and ANSI/AWS D1.8 (-16, -09 and -05), as applicable, for demand-critical welded connections. Weld filler metal must comply with Charpy V-Notch (CVN) toughness requirements set forth in Section J of ANSI/AISC 341 (-16 and -10), Appendix W and Appendix X of ANSI/AISC 341-05, as applicable. As the cast steel material of the connectors is not prequalified as set forth in Clause 3 of ANSI/AWS D1.1 (-15, -10 and -04) and heat treatment may include quenching and tempering, welds must be qualified by procedure qualification records in accordance with Clause 4 of ANSI/AWS D1.1 (-15, -10 and -04).

3.2.4 Bolts: The high-strength bolts used between the Cast ConneX[®] High-Strength Connector[™] and the gusset plate must comply with ASTM A325, ASTM F1852 or ASTM A490.

3.2.5 Structural Plates: The structural steel material used for the gusset plates must comply with Section A3 of ANSI/AISC 360 (-16, -10 and -05). For structures assigned to Seismic Design Category D, E, or F, the structural steel material must also comply with applicable Sections in ANSI/AISC 341 (-16, -10 and -05).

4.0 DESIGN AND INSTALLATION

4.1 SCBF or OCBF System Design:

The structural design procedures must be in accordance with Chapters 16 and 22 of the 2018, 2015, 2012 and 2009 IBC, as applicable, as Load and Resistance Factor or Allowable Stress Design. The design procedures must also be in accordance with ANSI/AISC 360 (-16,-10 and -05), as applicable, and the 2018 Cast ConneX[®] High-Strength Connector[™] Design Guide, 4th edition. As set forth in IBC Section 2205.2, when used as a portion of the seismic load-resisting system in Seismic Design Category D, E, or F, seismic design and detailing must comply with ASCE/SEI 7 (-16, -10 and -05) and ANSI/AISC 341 (-16, -10 and -05), as applicable. The connector must be considered to be within a protected zone and subject to provisions of Sections D1.3 and F2.5c of ANSI/AISC 341 (-16 and -10), and Sections C7.4 and C13.6 of ANSI/AISC 341 (-05), as applicable.

4.2 Brace Connection Design:

The connections must be designed and detailed in accordance with ANSI/AISC 341 (-16, -10 and -05) when the assemblage is a portion of a seismic load-resisting system, or ANSI/AISC 360 (-16, -10 and -05) for non-seismically loaded applications. When used to create an SCBF or OCBF in Seismic Design Category D, E, or F, the connections must develop the required strength in accordance with Sections F1 or F2 of ANSI/AISC 341 (-16, and -10), and Section 14 or Section 13 of ANSI/AISC 341 (-05), respectively, as applicable. The SCBF design must also comply with the requirements for the exception listed in Section F1.6 of ANSI/AISC 341 (-16 and -10), and Section 13.3b of ANSI/AISC 341 (-05), as applicable, as illustrated in Figure 3, or alternatively provide a rationale for using an alternative design and detailing method to ensure that the plastic

hinge at a brace end forms within the gusset plate and not within the connector, the connection between the connector and the gusset plate, nor within the brace.

The welded joint between a Cast ConneX[®] High-Strength Connector[™] and the connected hollow section brace member must provide complete joint penetration (CJP).

When the brace-connector assembly is to be field-bolted to the gusset plate, the bolted joint between the Cast ConneX[®] High-Strength Connector[™] and the gusset plate must be designed in accordance with ANSI/AISC 360 (-16, -10 and -05). For structures located in Seismic Design Category D, E, or F, design must also comply with Section D2.2 of ANSI/AISC 341 (-16 and -10), and Section C7.2 of ANSI/AISC 341 (-05), as applicable, using pretensioned high-strength bolts in joints with slip-critical faying surfaces conforming to Class A or Class B requirements.

When the brace-connector assembly is to be field-welded to the gusset plate, the connection between a Cast ConneX[®] High-Strength Connector[™] and the gusset plate must be made using fillet welds. The design must comply with ANSI/AWS D1.1 (-15, -10 and -04) with the modifications in ANSI/AISC 360 (-16, -10 and -05), as applicable.

Combining bolts and fillet welds is not allowed.

4.3 Fabrication and Erection:

The welded joint between a Cast ConneX[®] High-Strength Connector[™] and the connected HSS or pipe brace member must provide complete joint penetration (CJP), and this welding operation must be performed in the shop of a registered and approved fabricator.

A Welding Procedure Specification (WPS), prepared in accordance with Clause 6.6 of ANSI/AWS D1.8:2016, and Clause 6.1 of ANSI/AWS D1.8 (:2009 and :2005), and Section 1705.2 of the 2018, 2015 and 2012 IBC, Sections 1704.3 and 1708 of the 2009 IBC, must be developed by the steel fabricator for each base steel type, welding position, weld type, welding process, electrode manufacturer, and filler metal trade name for the electrode type selected; and for all essential variable changes set forth in Clause 7.7 of ANSI/AWS D1.1 (-15, -10 and -04) in the Procedure Qualification Record (PQR) that exceed allowable tolerances. For structures assigned to Seismic Design Categories D, E, and F, the WPS must also comply with supplemental requirements in Clause 6.1 of ANSI/AWS D1.8 (-16, -09 and -05) and Section J of ANSI/AISC 341 (-16 and -10), and Section 18 and Appendix Q of ANSI/AISC 341 (-05). Each WPS must be qualified in accordance with a documented PQR in accordance with Clause 4 of ANSI/AWS D1.1 (-15, -10 and -04).

[Table 1](#) provides a suggested test WPS for performing PQR, and the related WPS for production, assuming the test WPS is used.

Erection must be in conformance with ANSI/AISC 303 (-16, -10 and -05), Section 7, and must be consistent with the requirements noted in Chapter 22 of the IBC. The brace-connector assembly's connection to the gusset plate using either welds or bolts must be made either at an approved fabricator's shop or at the jobsite by the erector.

4.4 Quality Assurance:

4.4.1 Cast ConneX[®] High-Strength Connectors[™]: Non-destructive testing must be conducted by the manufacturer's qualified inspectors. The procedures for qualification of inspectors must be in accordance with American Society for Nondestructive Testing, Inc. (ASNT), TC-1A or an equivalent standard as set forth in the manufacturer's approved quality documentation. Applicable testing requirements include the following:

4.4.1.1 Tensile Requirements: Tensile tests must be performed for each heat in accordance with ASTM A370 and ASTM A781, and show compliance with requirements for the cast steel grade in accordance with ASTM A958 Grade SC8620 Class 80/50.

4.4.1.2 Charpy V-Notch (CVN) Requirements: CVN testing must be performed for each heat in accordance with ASTM A370 and ASTM A781. Three notched specimens must be tested with the first heat, and with each subsequent 20th ton (18 100 kg) of finished material. The specimens must have a minimum CVN toughness of 20 ft-lb (27 J) at 70°F (21°C).

4.4.1.3 Non-destructive Testing (NDT) of Castings:

4.4.1.3.1 Procedures: Radiographic testing (RT) as set forth in the approved quality documentation is conducted according to the procedures prescribed in ASTM E446 and ASTM E186, with an acceptance of Level III or better. Ultrasonic testing (UT) as set forth in the approved quality documentation is conducted according to the procedures set forth in ASTM A609 Procedure A, with an acceptance of Level 3 or better. Magnetic particle testing (MT) as set forth in the approved quality documentation is conducted according to

the procedures prescribed by ASTM E709 with an acceptance of Level III or better in accordance with ASTM A903. Visual inspection as set forth in the approved quality documentation must be performed in accordance with ASTM A802, with an acceptance of Level I.

4.4.1.3.2 Required NDT: First Article: The first article is defined as the first production casting made from a permanently mounted and rigged pattern. First Article Inspection (FAI) must be performed on the first casting produced from each pattern. The first article casting dimensions must be measured and recorded. FAI must include RT and MT.

4.4.1.3.3 Production Castings: UT, MT, and visual inspection must be performed on 100 percent of the casting production.

4.4.1.4 Weld Repair Procedures: Production castings with discontinuities that exceed the requirements of Section 4.4.1.3 of this report must be weld-repaired. Weld-repair of castings must be performed in accordance with ASTM A488. The same testing method that discovered the discontinuities must be repeated on repaired castings to confirm the removal of all discontinuities that exceed the requirements of Section 4.4.1.3 of this report.

4.4.2 Fabrication and Installation of Brace–Connector Assemblies:

4.4.2.1 Fabrication of Brace–to–Connector Assemblies: Cast ConneX[®] High-Strength Connectors[™] are supplied by Cast Connex Corporation. Fabrication of brace–connector assemblies must be performed by a registered and approved fabricator. The approved fabricator must comply with Section 1704.2.5 of the 2018, 2015 and 2012 IBC, or Section 1704.2.2 of the 2009 IBC, as applicable. For structures assigned to Seismic Design Category C, D, E or F, visual inspection and non-destructive testing (NDT) in accordance with Section 1705 of the 2018, 2015 and 2012 IBC, or Sections 1704 and 1707 of the 2009 IBC, as applicable must be performed. A visual inspection and testing program must be established by the registered design professional and must include the following items, at a minimum:

- a. Visual and Ultrasonic testing of Complete Joint Penetration (CJP) groove welds between the Cast ConneX[®] High-Strength Connector[™] and the round HSS or Pipe brace element in accordance with Chapter J of ANSI/AISC 341 (-16 and -10) or Appendix Q5 of ANSI/AISC 341-05, as applicable. This inspection and testing is to be conducted at the shop of the fabricator.
- b. Qualification of NDT personnel, and compliance with Clause 6.14.6 of ANSI/AWS D1.1 (-15, -10 and -04), as applicable, and ASTM E164, as appropriate.

4.4.2.2 Jobsite: The approved construction documents for each project must include a written quality assurance program, which, at a minimum, must include the following:

- A statement of special inspection complying with Section 1704 and 1705 of the 2018, 2015 and 2012 IBC, or Sections 1705, 1706, and 1707 of the 2009 IBC as applicable, must be included in the structural design drawings and specifications prepared by the registered design professional.
- Special inspection provisions for steel construction must comply with Sections 1704.2.5, 1705.2 and 1705.12 of the 2018, 2015 and 2012 IBC, or Sections 1704.2, 1704.3 and 1707.2 of the 2009 IBC, as applicable, and Chapter J of ANSI/AISC 341 (-16 and -10) or Section 18 and Appendix Q of ANSI/AISC 341-05, as applicable, and must be included in the statement of special inspection.
- Special inspection must verify compliance of steel with specifications, steel identification, and identification of high-strength bolts, nuts, washers, if applicable, in accordance with IBC Section 2203 and the approved construction documents.
- When the brace–connector assembly is to be field-bolted to the gusset plates, inspection of high-strength bolt installation must comply with Section 1705.2.1 of 2018, 2015 and 2012 IBC, or Section 1704.3.3 of 2009 IBC as applicable, and Chapter J7 of ANSI/AISC 341 (-16 and -10), or Appendix Q5.3 of ANSI/AISC-341-05, as applicable.
- When the brace–connector assembly is to be field-welded to the gusset plates, special inspection must verify weld filler metal compliance with specifications, weld filler metal identification, qualification of welders, use of appropriate welding materials, storage conditions for welding materials, welded joint preparations, conformance of welding procedures with applicable ANSI/AISC 341 (-16, -10 and -05) and ANSI/AWS D1.1 (-15, -10 and -04) requirements, and fabrication tolerances. For structures assigned to Seismic Design Categories C, D, E and F (IBC or ASCE/SEI 7), visual inspection and non-destructive testing (NDT) in accordance with Sections 1704 and 1705 of the 2018, 2015 and 2012 IBC, or Sections 1704 and 1707 of the 2009 IBC, as applicable, must be performed. A visual inspection and testing program must be

established by the registered design professional in the statement of special inspection and must include the following items, at a minimum:

- Visual inspection of all fillet welds between the Cast ConneX[®] High-Strength Connector[™] and the gusset plate in accordance with Chapter J6 of ANSI/AISC 341 (-16 and -10), or Appendix Q5, of ANSI/AISC 341-05, as applicable.
- Qualification of NDT personnel, and compliance with Clause 6.14.6 of ANSI/AWS D1.1 (-15, -10 and -04), as applicable, and ASTM E164, as appropriate.

5.0 CONDITIONS OF USE:

The Cast ConneX[®] High-Strength Connectors[™] described in this report comply with, or are suitable alternatives to what is specified in, those codes listed in Section 1.0 of this report, subject to the following conditions:

- 5.1 Connection described in Sections 3.2.3, 3.2.4 and 3.2.5 of this report must be designed in accordance with this report, the applicable code, and the “Cast ConneX[®] High-Strength Connector[™] Design Guide,” and must be prepared by a registered design professional.
- 5.2 Structural design drawings and specifications, shop drawings, and erection drawings must comply with Section A4 of ANSI/AISC 360 (-16, -10 and -05), and Section I of ANSI/AISC 341 (-16 and -10), or Section 5 of ANSI/AISC 341-05, as applicable.
- 5.3 Fabrication and erection of brace–connector assemblies must comply with Sections 4.3 and 4.4 of this report and the “Cast ConneX[®] High-Strength Connector[™] Design Guide,” and must either be done by a fabricator approved by the building official, as set forth in Section 1704.2.5 of the 2018, 2015 and 2012 IBC, or Section 1704.2.2 of the 2009 IBC, as applicable, or must be under special inspection as set forth in Section 1705 of the 2018, 2015 and 2012 IBC, or Section 1704 of the 2009 IBC, as applicable.
- 5.4 Quality assurance must be provided in accordance with Section 4.4 of this report.

6.0 EVIDENCE SUBMITTED

Data in accordance with the [ICC-ES Acceptance Criteria for Cast ConneX[®] High-Strength Connectors[™] for Use as Bracing Connections in Accordance with AISC 341 \(AC427\)](#), dated October 2011 (editorially revised October 2018).

7.0 IDENTIFICATION

- 7.1 Each Cast ConneX[®] High-Strength Connector[™] as described in this report is identified by raised markings on the connector that show the manufacturer’s logo (a stylized “X”); the connector name in metric diameter size [for example, HSC-168 corresponds to a Cast ConneX[®] High-Strength Connector[™] accommodating hollow section elements of 6⁵/₈ inches (168 mm) outer diameter]; and a serial number which provides traceability to heat number, chemical and physical analysis reports, and reports of non-destructive testing. Product labeling includes the report holder’s name, the manufacturer’s name and address, the evaluation report number (ESR-3031) and the name of the inspection agency (ICC-ES LLC).
- 7.2 The report holder’s contact information is the following:

CAST CONNEX CORPORATION
100 CONSILIUM PLACE, SUITE 311
TORONTO, ONTARIO M1H 3E3
CANADA
(416) 806-3521
www.castconnex.com
info@castconnex.com

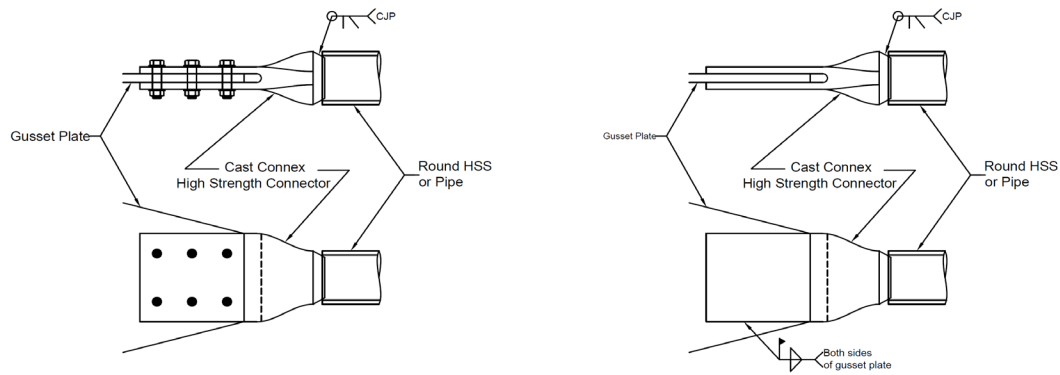

FIGURE 1—CAST CONNEX HIGH-STRENGTH CONNECTOR

TABLE 1—SUGGESTED TEST WPS FOR PERFORMING PQR

RECOMMENDATIONS FOR PQR	RECOMMENDATIONS FOR WPS (see ANSI/AWS D1.1:2010 Tables 3.6, and 4.5)
ASTM A958 SC8620 80/50 to ASTM A500 grade B	no change
Thickness: 5/16"	5/32" to 5/8"
Weld type: TYK single bevel CJP groove weld (see AWS D1.1:2010 Figure 3.8 and 3.9, Detail A)	no change
Position: test both 2G and 5G	all
Root Opening: 1/8"	+/- 1/16" (1/16" – 3/16")
Groove Angle: 60 degrees	+ 10, - 5 degrees (55 – 70 degrees)
Process: FCAW-G	no change
Filler Metal Manufacturer: Lincoln Electric Co.	no change
Product Name: UltraCore 71A85	no change
Classification(s): E71T-1M-H8, E71T -9M-H8	no change
Diameter: 0.045"	no change
Shielding Gas: 80% Argon, balance CO2	75-85% Argon, balance CO2
Shielding Gas Flow Rate: 45 CFH	+ 30%, - 20% (36 – 58 CFH)
Current and Polarity: DC+	no change
Output: CV	no change
Contact Tube to Work Distance: 1"	+/- 1/4" (3/4" – 1 1/4")
Voltage: 26 V	+/- 7% (24.2 – 27.8 V)
Amperage: 190 A	+/- 10% (171 – 209 A)
Wire Feed Speed: 350 ipm	+/- 10% (315 – 385 ipm)
Travel Speed: 6 ipm	+/- 25% (5.5 – 7.5 ipm)
Heat Input: (Voltage * Amperage * 0.06 / Travel Speed) = 49 kJ/inch	+ 0, - 20 kJ/inch (29 – 49 kJ/inch)
minimum preheat: 225F	no change
Measured PQR preheat and interpass temperatures	+ not to exceed maximum interpass temperature - 25 degrees
maximum preheat and interpass temperature: 400F	no change
Notes:	
For the physical properties and bend tests of the completed weld, plate testing similar to Figure 4.11 of ANSI/AWS D1.1:2015, with a 60 degree single bevel groove weld shall be conducted. The test plates for the ASTM A958 SC8620 80/50 material can be supplied by Cast Connex Corporation.	
For the ASTM A500 material, the test plates shall be cut from the flat side of a large box tube of the same specification and grade of steel being used for the brace (for round HSS braces), or of a flattened section of cut pipe wall.	

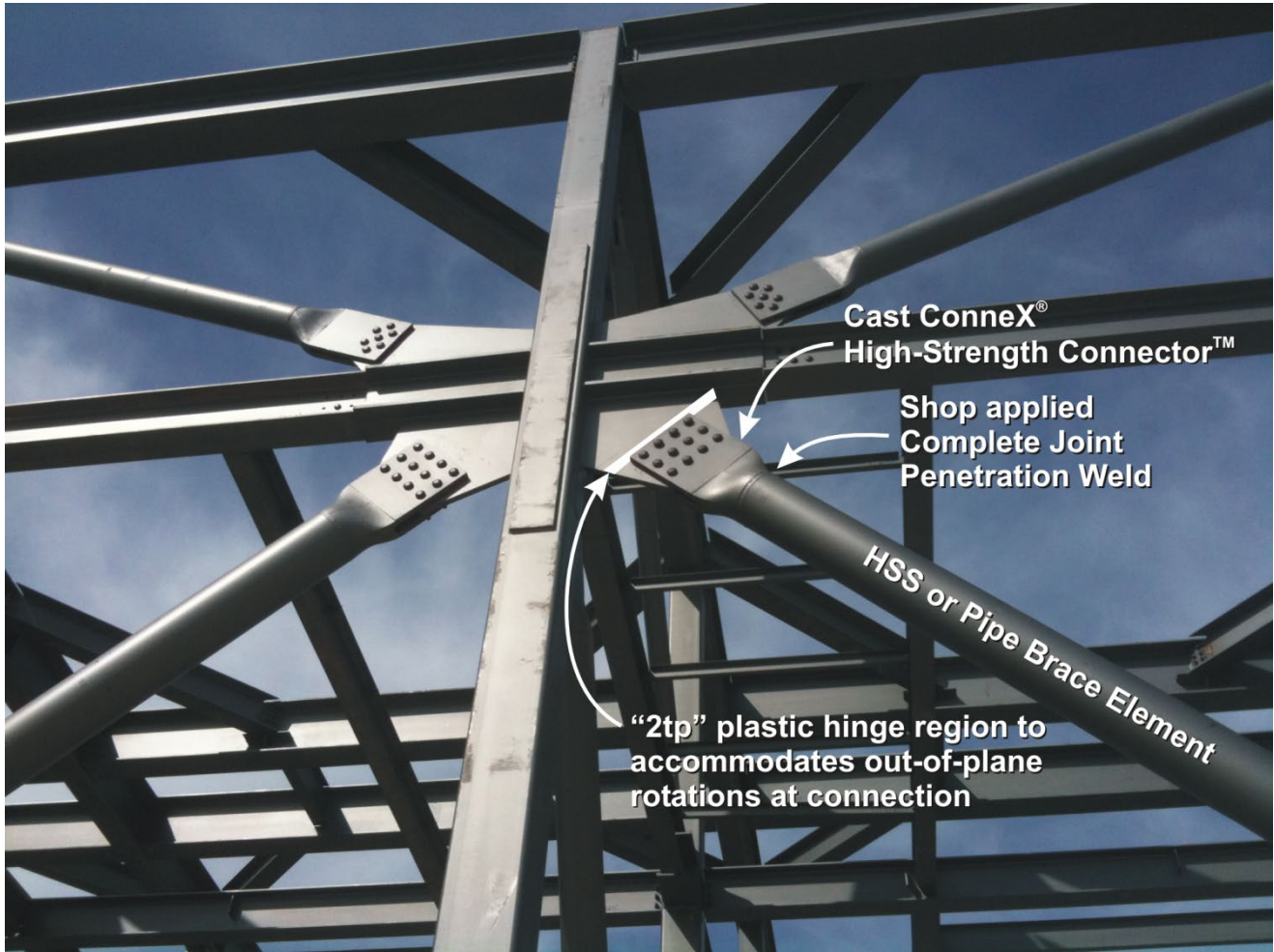

FIGURE 2—CAST CONNEX[®] HIGH-STRENGTH CONNECTOR[™] SHOWN IN FIELD-BOLTED CONFIGURATION IN BRACED FRAME

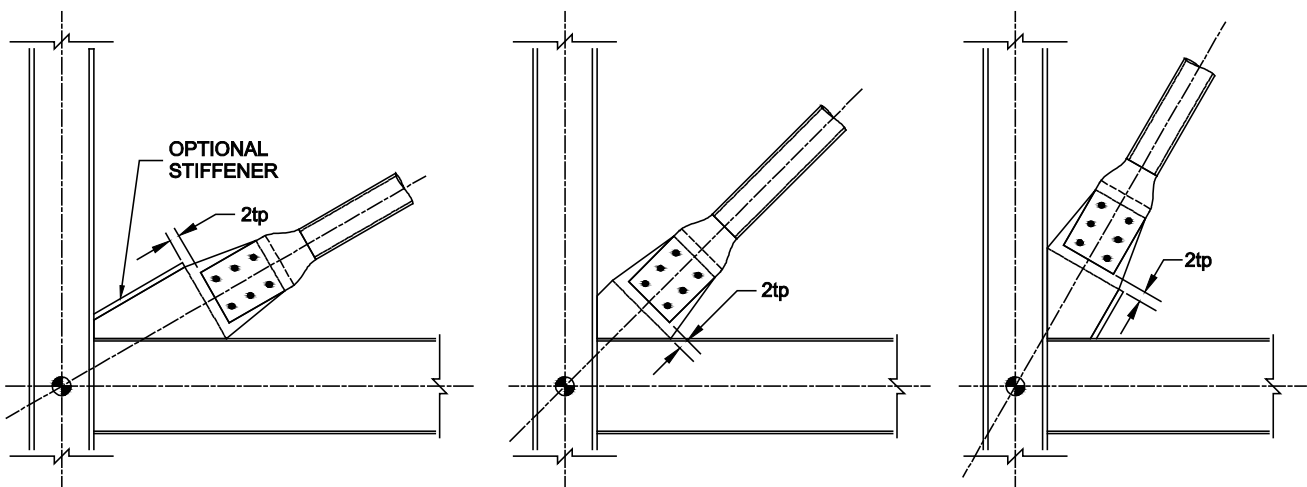

FIGURE 3—GUSSET PLATE DETAILING IN SCBF TO ACCOMMODATE OUT-OF-PLANE INELASTIC DEFORMATION OF BRACE FOR VARIOUS BRACING ANGLES

DIVISION: 05 00 00—METALS
Section: 05 12 00—Structural Steel Framing

REPORT HOLDER:

CAST CONNEX CORPORATION

EVALUATION SUBJECT:

CAST CONNEX® HIGH-STRENGTH CONNECTORS™

1.0 REPORT PURPOSE AND SCOPE**Purpose:**

The purpose of this evaluation report supplement is to indicate that Cast ConneX® High-Strength Connectors™, described in ICC-ES evaluation report [ESR-3031](#), have also been evaluated for compliance with the code noted below as adopted by the Los Angeles Department of Building and Safety (LADBS).

Applicable code edition:

2020 *City of Los Angeles Building Code* (LABC)

2.0 CONCLUSIONS

The Cast ConneX® High-Strength Connectors™, described in Sections 2.0 through 7.0 of the evaluation report [ESR-3031](#), complies with the LABC Chapter 22, and is subject to the conditions of use described in this supplement.

3.0 CONDITIONS OF USE

The Cast ConneX® High-Strength Connectors™ described in this evaluation report supplement must comply with all of the following conditions:

- All applicable sections in the evaluation report [ESR-3031](#).
- The design, installation, conditions of use and identification of the connectors are in accordance with the 2018 *International Building Code*® (IBC) provisions noted in the evaluation report [ESR-3031](#).
- The design, installation and inspection are in accordance with additional requirements of LABC Chapters 16 and 17, as applicable.
- When the connectors are used with special concentrically braced frames, the additional requirements of LABC Section 2205.3 must apply.
- Welding must comply with the requirements of LABC Section 2204.1

This supplement expires concurrently with the evaluation report, reissued December 2023.

DIVISION: 05 00 00—METALS

Section: 05 12 00—Structural Steel Framing

REPORT HOLDER:

CAST CONNEX CORPORATION

EVALUATION SUBJECT:

CAST CONNEX® HIGH-STRENGTH CONNECTORS™

1.0 REPORT PURPOSE AND SCOPE

Purpose:

The purpose of this evaluation report supplement is to indicate that Cast ConneX® High-Strength Connectors™, described in ICC-ES evaluation report ESR-3031, has also been evaluated for compliance with the code noted below.

Applicable code edition:

2019 *California Building Code*® (CBC)

For evaluation of applicable chapters adopted by the California Office of Statewide Health Planning and Development (OSHPD)AKA: California Department of Health Care Access and Information (HCAI) and the Division of State Architect (DSA), see Sections 2.1.1 and 2.1.2 below.

2.0 CONCLUSIONS

2.1 CBC:

The Cast ConneX® High-Strength Connectors™, described in Sections 2.0 through 7.0 of the evaluation report ESR-3031, comply with CBC Chapter 22, provided the design and installation are in accordance with the 2018 *International Building Code*® (IBC) provisions noted in the evaluation report and the additional requirements of CBC Chapters 16, 17 and 22, as applicable.

2.1.1 OSHPD:

The applicable OSHPD Sections and Chapters of the CBC are beyond the scope of this supplement.

2.1.2 DSA:

The applicable DSA Sections and Chapters of the CBC are beyond the scope of this supplement.

This supplement expires concurrently with the evaluation report, reissued December 2023.