



PERFORMANCE FEATURES

UL Listing

Suitable for damp locations

Lifespan:

Lumen Maintenance, L70 > 54,000 hours
 Rated Life: 100,000 hours

LEDs:

Long-life, high-efficacy, micro-power LEDs

Finish

Long lasting white finish with high durability

Optional Accessories

- Suspension mount kit
- Cable suspending mounting kit
- V-hooks & Chain suspending mounting kit
- Right angle connection kit
- Wire guards, square profile or arc profile optional
- Occupancy sensor
- EM battery

IESNA LM-79 & IESNA LM-80 Testing:

LED luminaires have been tested based on IESNA LM-79 and LM-80 by a third-party laboratory

Housing and lens

Sheet metal stamping

Mounting

Surface mount cover plate included

Dimming Driver:

Driver includes dimming control wiring for 0-10V dimming systems. The dim-to-off voltage threshold of optional 12V AUX integrated driver ranges from 0.1V to 0.5V.

SKU GUIDE

Model Section		STR4-40W-CCT-DV2-F-WHSM						
STR4		40W	CCT	DV2		F	WHSM	
BODY TYPE PREFIX	MODEL NAME	WATTAGE	CCT (if selectable = CCT)	DRIVER	VOLTAGE	ELECTRICAL OPTIC/LENS	HOUSING FINISH	MOUNTING
STR	2 - 2FT 4 - 4FT	25W - 15/20/25 40W - 25/30/40	3500/4000/ 5000 3500/4000/ 5000	D - 0-10V Dimming	V2 - 120-277V (Universal Voltage)	F-Frosted Lens	WH-White Finish	SM-Surface Mount

Available Options	
Emergency Backup	Controls
EM1400 1400lm EM2000 2000lm	OS Occupancy Sensor OSDL Occ. Sensor w/ Daylight OSDL/BT Wireless Bluetooth Occupancy Sensor OSDL/IR Multi-Level Occ Sensor w/ wireless config. OSDL/BTEZ-B Simple Occupancy Sensor

SKU SPECIFICATION

SKU #	Nominal Wattage	CCT	Lumens	Efficacy (LPW)	CRI	Input Voltage	Operating Temp.	Certifications	Avail Options
STR2-25W-CCT-DV2-MS-F-WHSM	15/20/25	3500/ 4000/ 5000K	3250/ 2600/ 1950	130	>80	120-277V	-4(Degree) F/ -20(Degree)C to 122(Degree) F/ -50(Degree) C	UL listed DLC listed	Occupancy sensor, EM battery
STR4-40W-CCT-DV2-MS-F-WHSM	25/30/40	3500/ 4000/ 5000K	5200/ 3900/ 3250	130	>80	120-277V	-4(Degree) F/ -20(Degree)C to 122(Degree) F/ -50(Degree) C	UL listed DLC listed	Occupancy sensor, EM battery

PRODUCT DIMENSIONS

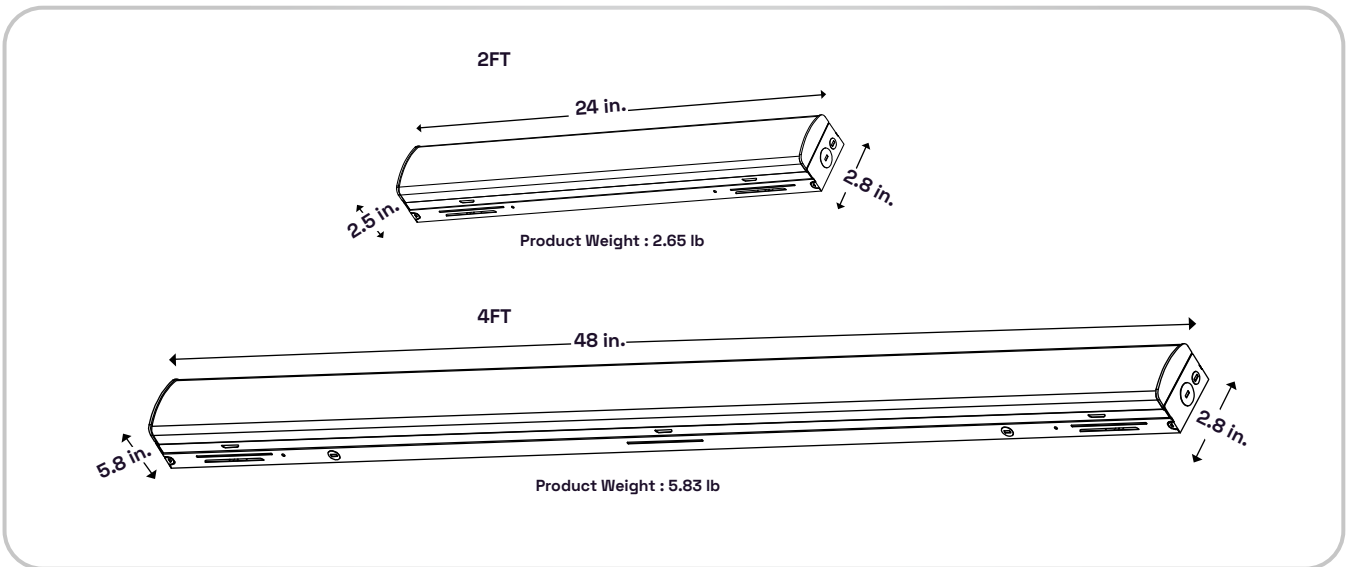

PACKAGING DIMENSIONS

SKU #	Standard Pack	Dimension
STR2-25W-CCT-DV2-MS-F-WHSM	2 Pack	L 23.2 in x W 5.9in x H 4.8in
STR4-40W-CCT-DV2-MS-F-WHSM	2 Pack	L 48.3in x W 5.9in x H 4.8in

ACCESSORIES

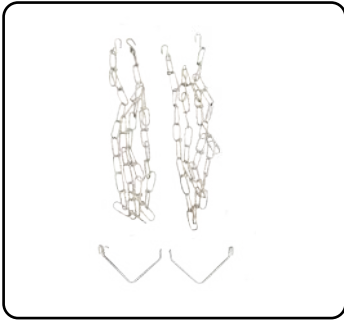

V-Hook
Mounting Kit

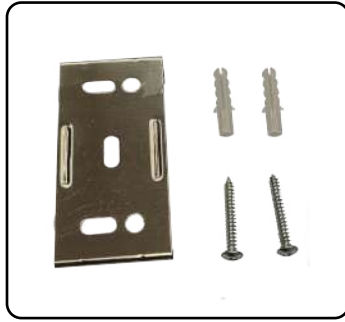

Strip_SMK



Row connector

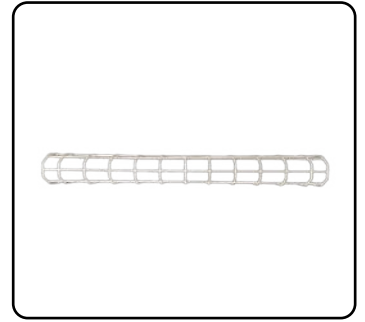

Strip Wire Guards



6' Whip

PHOTOMETRICS

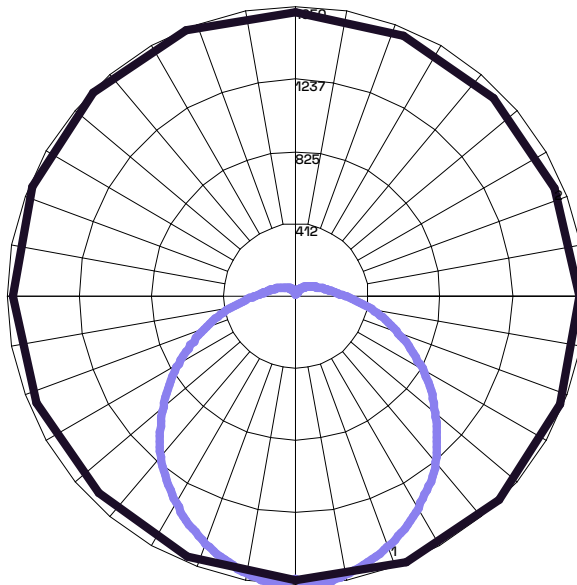

Maximum Candela = 1649.7 Located At Horizontal Angle = 292.5, Vertical Angle = 5
1 - Vertical Plane Through Horizontal Angles (292.5 - 112.5) (Through Max. Cd.)
2 - Horizontal Cone Through Vertical Angle (5) (Through Max. Cd.)