

# LED Strip Light Installation Instructions



**THIS INSTALL MANUAL IS APPLICABLE FOR  
MODEL NO : STR2-25W / STR4-40W**

## SAFETY INFORMATION

### IMPORTANT

THIS PRODUCT MUST BE INSTALLED IN ACCORDANCE WITH THE APPLICABLE NATIONAL ELECTRICAL CODE AND LOCAL BUILDING CODES BY A PERSON FAMILIAR WITH THE CONSTRUCTION AND OPERATION OF THE PRODUCT AND THE HAZARDS INVOLVED.

### PRECAUTIONS

- Please read and understand this entire manual before attempting to assemble, install, or operate this light fixture.
- This light fixture requires a 120-277 Volt AC power source.
- Some codes require installation by a qualified electrician.
- This light fixture must be properly grounded.
- Make sure connections are secure using wire nuts, crimp-on lugs or other approved connecting devices.
- This light fixture should be installed indoors to a ceiling, recessed mount application



**WARNING:** Turn the power off at the circuit breaker or fuse. Place tape over the circuit breaker switch and verify power is off at the light fixture.



**CAUTION:** Burn hazard. Allow the light fixture to cool before touching.



**NOTICE:** If using dimming function, only connect to 0-10V approved dimming switches or control system



**NOTICE:** FCC Regulations state that any unauthorized changes or modifications to this equipment not expressly approved by the manufacturer could void the user's authorization to operate this equipment.



**INFORMATION:** The device is tested and found to comply with Part 15 of the FCC Rules. Operation is subject to two conditions: (1) This device may not cause harmful interference and, (2) this device must accept any interference received, including any interference that may cause undesired operation. These limits are designed to provide reasonable protections against harmful interference when the equipment is operated in a commercial environment.

**NOTE:** This equipment has been tested and found to comply with the limits for a Class B digital device, pursuant to part 15 of the FCC rules. These limits are designed to provide reasonable protection against harmful interference in a residential installation. This equipment generates uses and can radiate radio frequency energy and, if not installed and used in accordance with the instructions may cause harmful interference to radio communications. However, there is no guarantee that interference will not occur in a particular installation. If this equipment does cause harmful interference to radio or television reception, which can be determined by turning the equipment off and on, the user is encouraged to try to correct the interference by one or more of the following measures

- Reorient or relocate the receiving antenna
- Increase the separation between the equipment and receiver.
- Connect the equipment into an outlet on a circuit different from that to which the receiver is connected
- Consult the dealer or an experienced radio/TV technician for help

**NOTICE:** Green ground screw provided in proper location. Do not relocate.

**NOTICE:** Minimum 90° supply conductors.

**NOTICE:** Specifications and dimensions subject to change without notice.

**NOTICE:** Suitable for Dry or Damp location,

### General Wiring Diagram

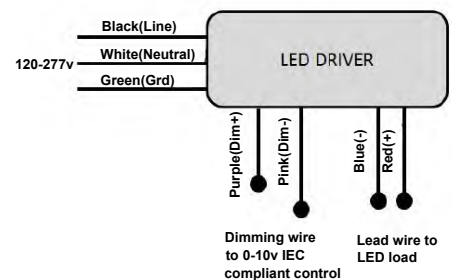

# LED Strip Light Installation Instructions



## INSTALLATION

### A:Chain Suspended Mounting

1. Take out the light fixture and accessories package from the box.

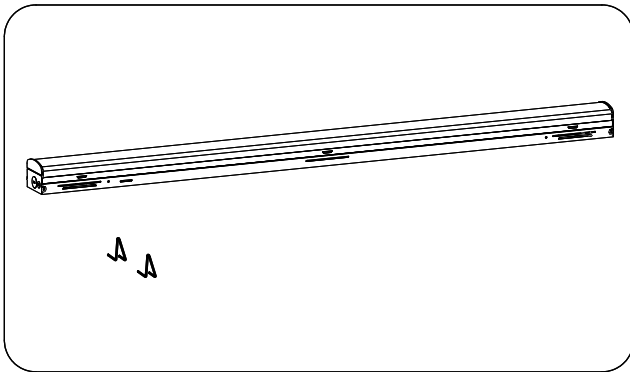

2. Connect the V-hook to the lamp.

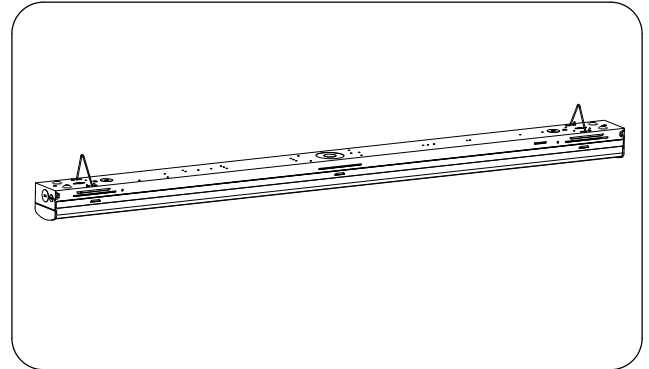

3. Attach chain to the V-hooks.

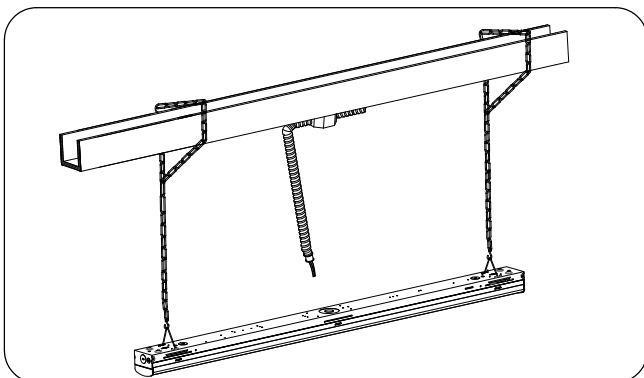

4. Connect the AC wires.

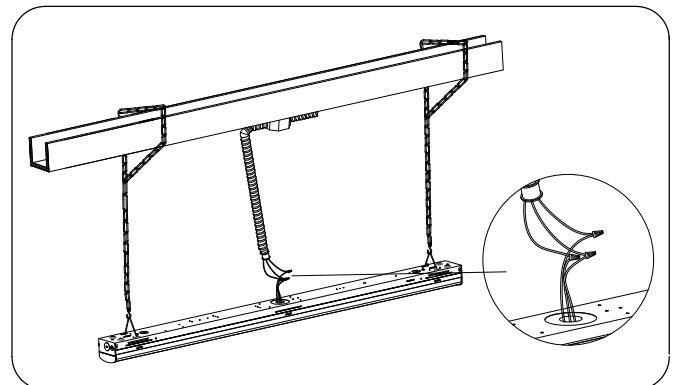

5. The installation is completed.

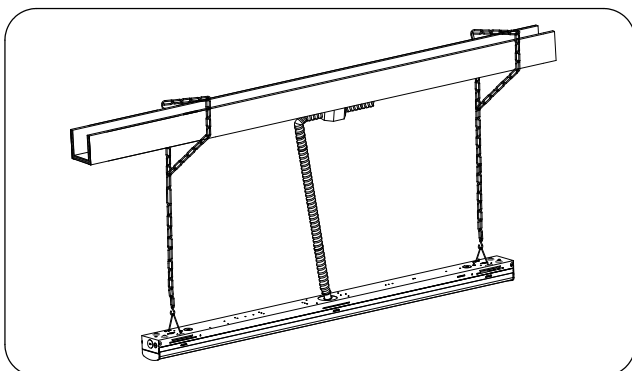

# LED Strip Light Installation Instructions



## INSTALLATION

### B: Surface Mounting

1. Take out the light fixture and accessories package from the box.

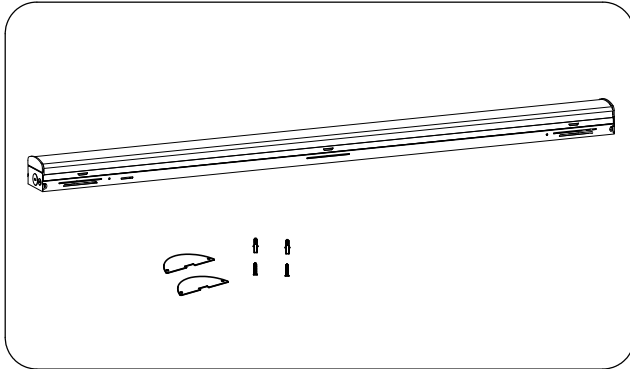

2. Fix the baffle on the lamp.

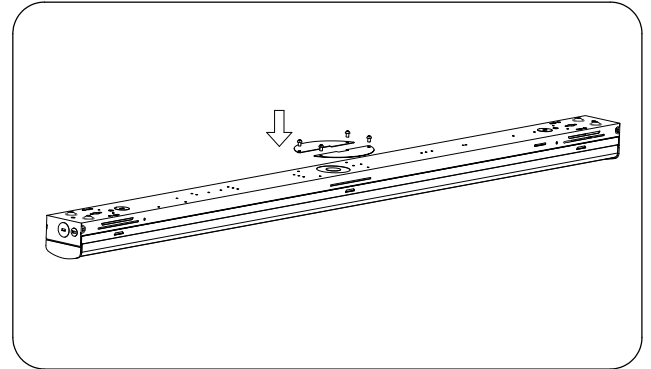

3. Open the module board down.

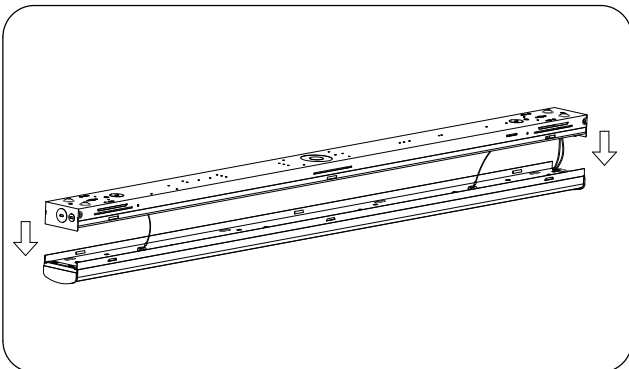

4. Fix the lamp to the ceiling with the plastic sleeve and screws provided.

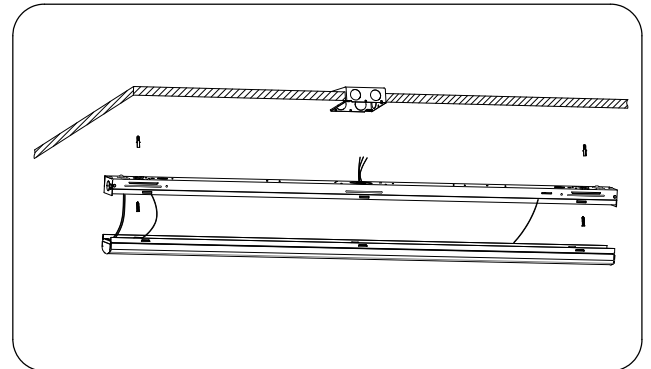

5. Wire to main power through the junction box.

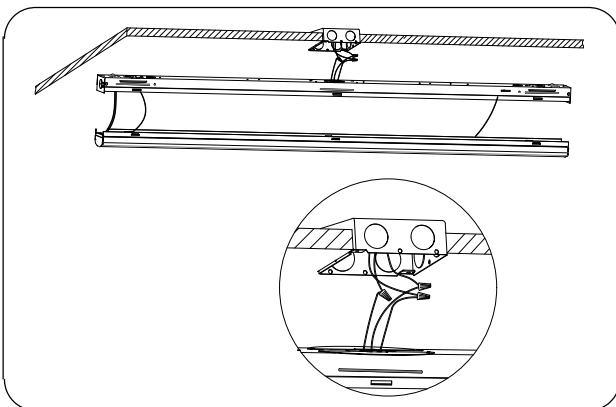

6. Assemble the module board upwards.  
The installation is completed.

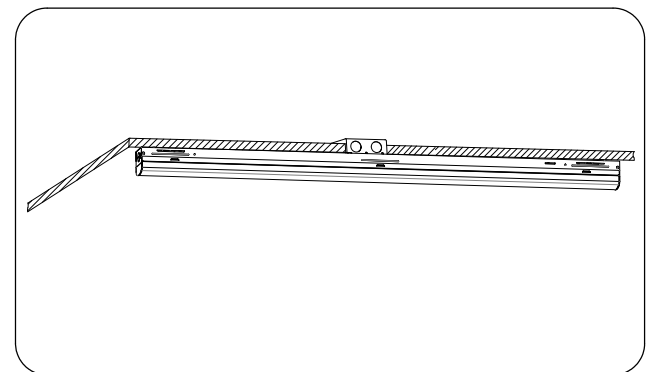

# LED Strip Light Installation Instructions



## INSTALLATION

### Field-Adjustable Wattage & CCT

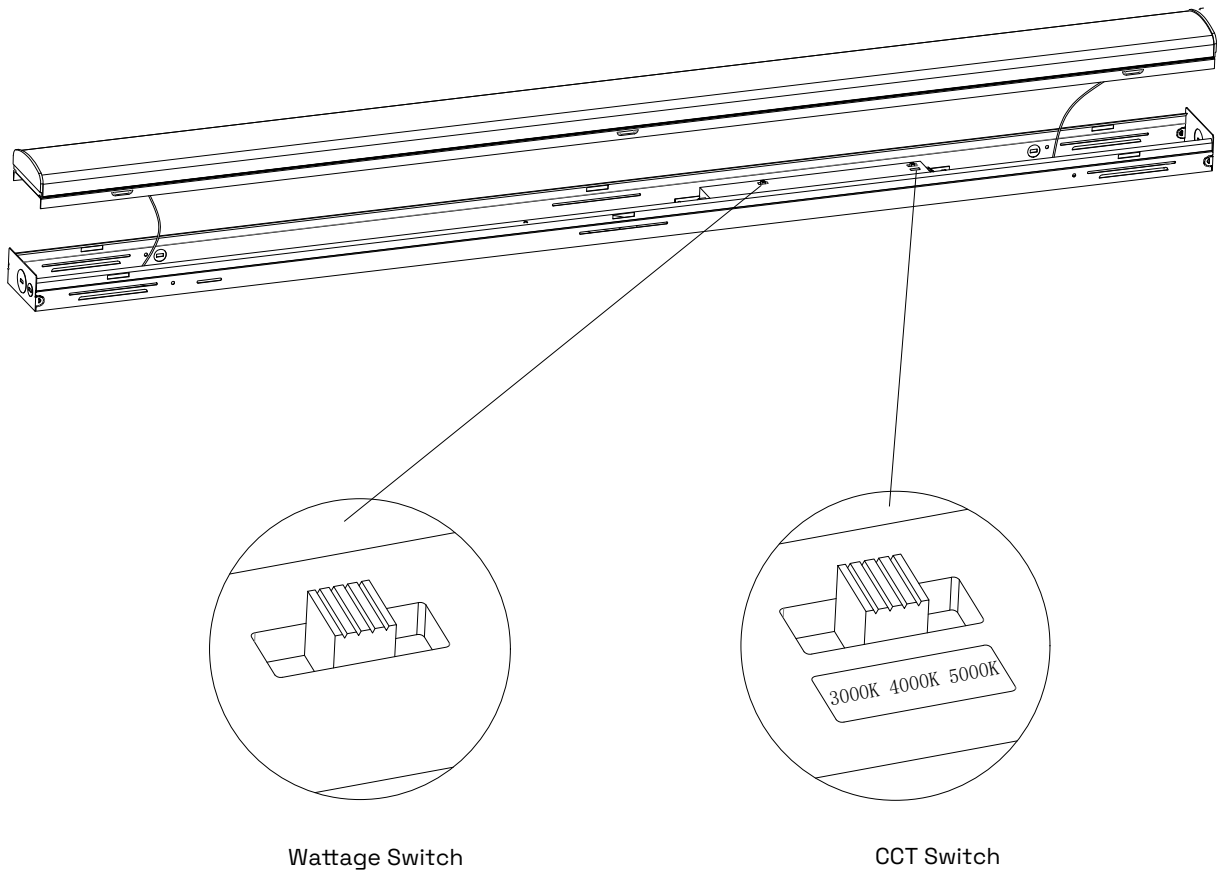

Wattage Switch

CCT Switch

The end users may adjust the color temperature and lumen output respectively by the two DIP switch. Each DIP switch is accommodated with 3 options (left, middle and right), corresponding to 3 color temperatures and 3 powers respectively, which can perform the desired color temperature and lumen output combination.

1. DIP switches are located on the side of the fixture.
2. Select a wattage and color temperature by sliding switch left or right respectively to the desired value.