

DUAL HEAD EMERGENCY LIGHT

Installation Instructions



**THIS INSTALL MANUAL IS APPLICABLE FOR
MODEL NO : DH-EL-SQ**

SAFETY INFORMATION

IMPORTANT

THIS PRODUCT MUST BE INSTALLED IN ACCORDANCE WITH THE APPLICABLE NATIONAL ELECTRICAL CODE AND LOCAL BUILDING CODES BY A PERSON FAMILIAR WITH THE CONSTRUCTION AND OPERATION OF THE PRODUCT AND THE HAZARDS INVOLVED.

PRECAUTIONS

- Please read and understand this entire manual before attempting to assemble, install, or operate this light fixture.
- This light fixture requires a 120-277 Volt AC power source.
- Some codes require installation by a qualified electrician.
- This light fixture must be properly grounded.
- Make sure connections are secure using wire nuts, crimp-on lugs or other approved connecting devices
- Equipment should be mounted securely in locations and at heights where it will not be readily subjected to tampering by unauthorized personnel.



WARNING: Turn the power off at the circuit breaker or fuse. Place tape over the circuit breaker switch and verify power is off at the light fixture.



CAUTION: Burn hazard. Allow the light fixture to cool before touching.



NOTICE: FCC Regulations state that any unauthorized changes or modifications to this equipment not expressly approved by the manufacturer could void the user's authorization to operate this equipment.



INFORMATION: The device is tested and found to comply with Part 15 of the FCC Rules. Operation is subject to two conditions: (1) This device may not cause harmful interference and, (2) this device must accept any interference received, including any interference that may cause undesired operation. These limits are designed to provide reasonable protections against harmful interference when the equipment is operated in a commercial environment.

NOTE: This equipment has been tested and found to comply with the limits for a Class B digital device, pursuant to part 15 of the FCC rules. These limits are designed to provide reasonable protection against harmful interference in a residential installation. This equipment generates uses and can radiate radio frequency energy and, if not installed and used in accordance with the instructions may cause harmful interference to radio communications. However, there is no guarantee that interference will not occur in a particular installation. If this equipment does cause harmful interference to radio or television reception, which can be determined by turning the equipment off and on, the user is encouraged to try to correct the interference by one or more of the following measures

- Reorient or relocate the receiving antenna
- Increase the separation between the equipment and receiver.
- Connect the equipment into an outlet on a circuit different from that to which the receiver is connected
- Consult the dealer or an experienced radio/TV technician for help

DUAL HEAD EMERGENCY LIGHT

Installation Instructions



INSTALLATION

IMPORTANT

Let the battery charge up for at least 24 hours. Then normal operation of this unit should take effect. To check, press the "TEST" button. The LED lamps on the unit should turn ON. During an electrical power failure, the LED lamps will automatically come on for a minimum of 90 minutes. In accordance with NFPA 101, your emergency lighting system must be tested monthly for a minimum of 30 seconds and annually for 90 minutes. Refer to your local codes for any additional requirements that may apply.

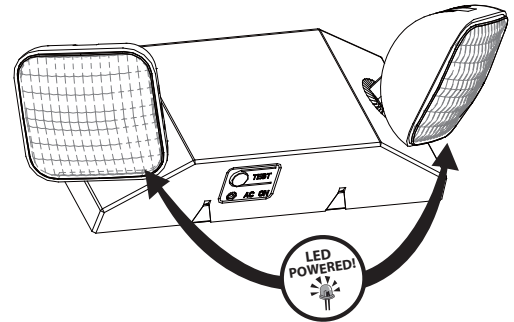

IMPORTANT SAFEGUARDS

When using electrical equipment, basic safety precautions should always be followed including the following:

READ AND FOLLOW ALL SAFETY INSTRUCTIONS

1. Do not use outdoors.
2. Equipment should be mounted in locations and at heights where it will not be subject to tampering by unauthorized personnel.
3. Do not mount near gas or electric heaters.
4. The use of accessory equipment not recommended by the manufacturer may cause an unsafe condition.
5. Do not use this equipment for anything other than its intended use.
6. Servicing of this equipment should be performed by qualified personnel.
7. Disconnect AC power before servicing.

SAVE THESE INSTRUCTIONS

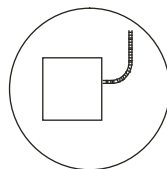
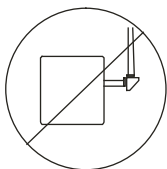

FLEXIBLE CONDUIT ONLY

INSTALLATION (J-BOX MOUNTING)

1. Feed fixture leads through the back plate and connect to AC power supply (Fig A). For 120V use black and white wires and for 277V, use red and white wires.
2. Attach back plate to J-Box and secure with screws.
3. Complete the battery connection. (Fig. B)
4. Align snaps and push housing directly onto the back plate (Fig. C). Apply continuous AC power and press "TEST" button to check light.

INSTALLATION (CONDUIT)

1. Secure back plate to wall surface. Route wires through hole in conduit flange and make conduit connection. For 120V, use black and white wires and for 277V, use red and white wires.
2. Complete the battery connection (Fig. B).
3. Align snaps and push housing directly onto the back plate (Fig. C). Apply continuous AC power and press "TEST" button to check light.

Contact us : For support & assistance, please feel free to contact us below.

E-Mail: info@medinahpower.com | Web: www.medinahpower.com | Ph: +1 (844) 870-5337

DUAL HEAD EMERGENCY LIGHT

Installation Instructions



INSTALLATION I:

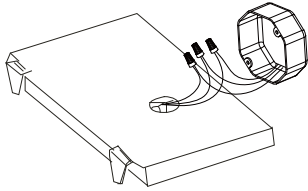

Fig.A (J-Box)

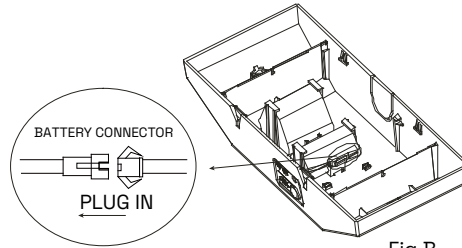

Fig.B

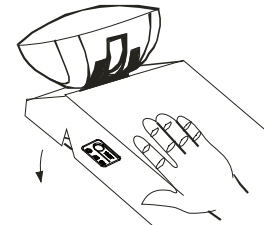

Fig.C

WARNING:

Unused wires must be capped using enclosed wire nuts.

OPERATION

1. During an electrical power failure, the LED lamps will automatically come on for a minimum of 90 minutes.
2. To test, depress the "TEST" switch. The emergency LED lamps will illuminate. When the switch is released, the lamps will go off.

WIRING DIAGRAM

REMOTE CAPABLE

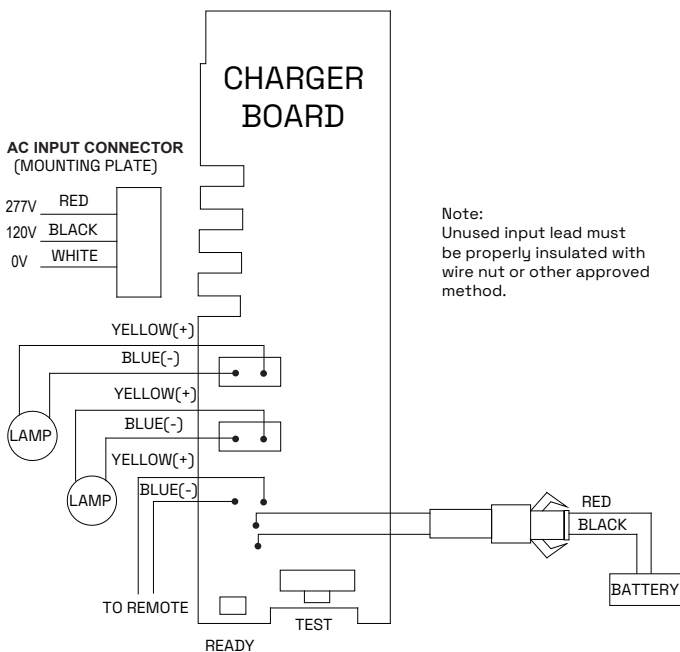

Note:
Use 18-22 AWG stranded wire to connect remote lamp heads.

REGULAR

