

H HEAD

PROVEN DESIGN WITH COUNTLESS CONFIGURATIONS



Wide Range of Pipe Sizes



Extensive Catalog of Configurations



Modular Construction



Commercially Available Consumables



Extended Cross Seam Adjustment



Remote Welding Capabilities

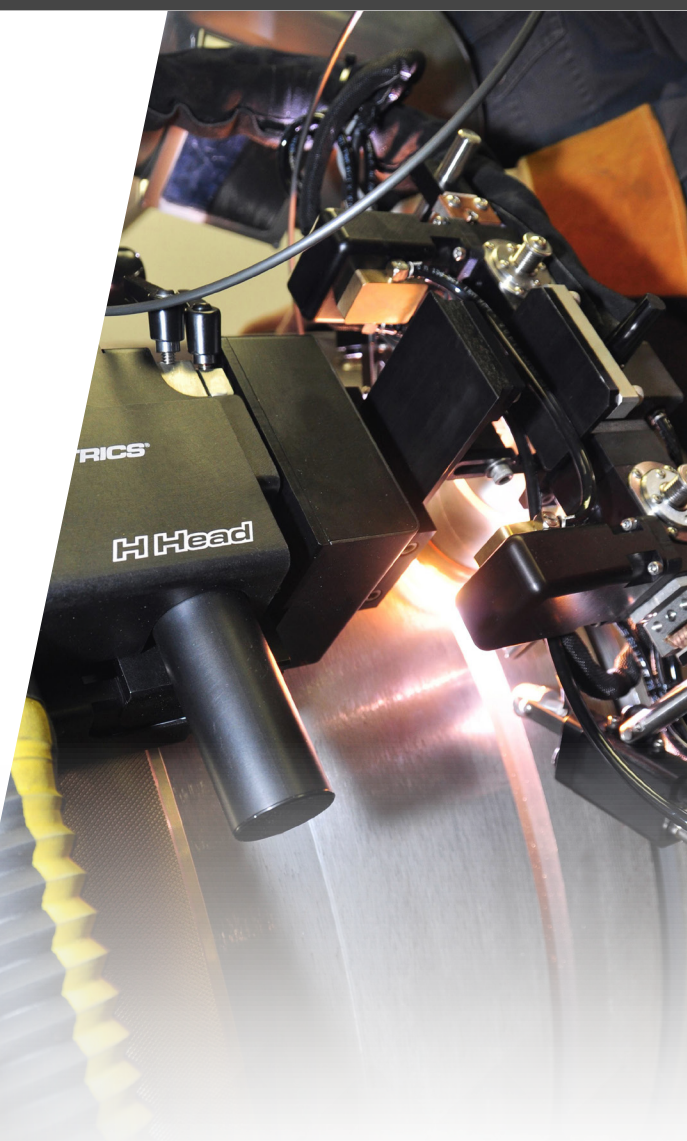
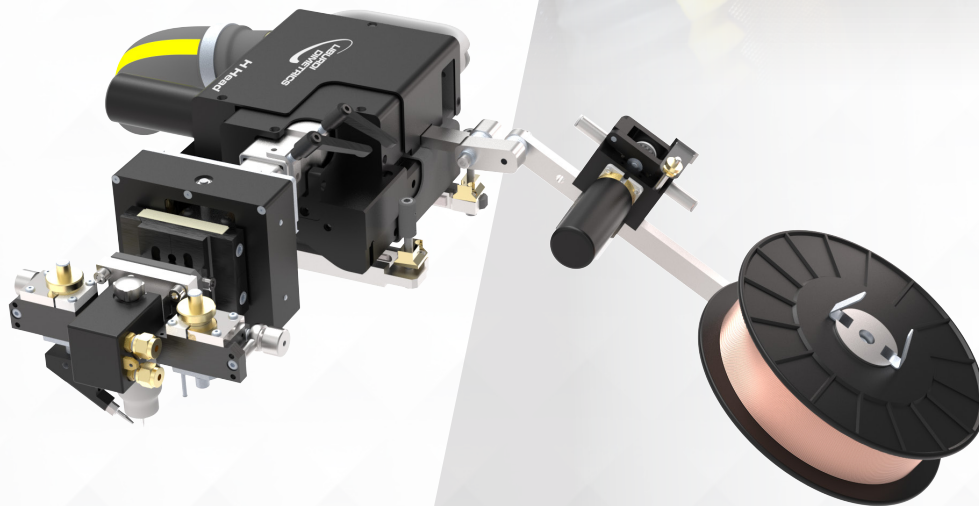

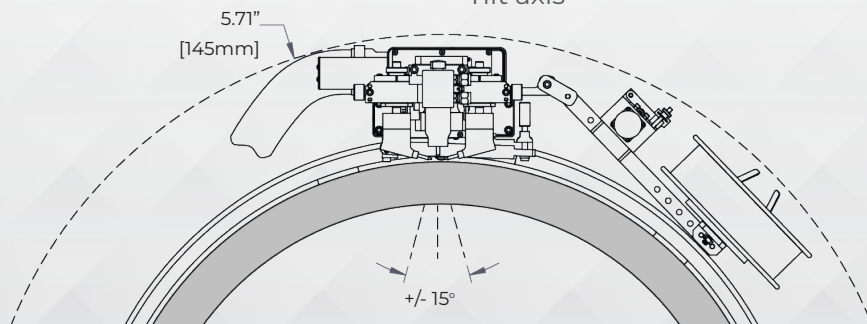
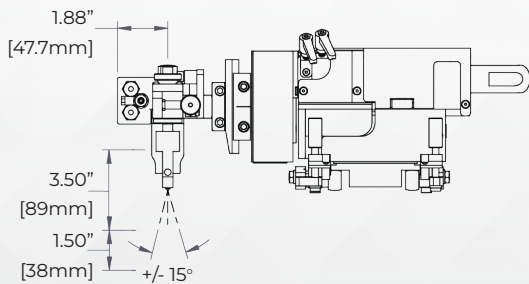
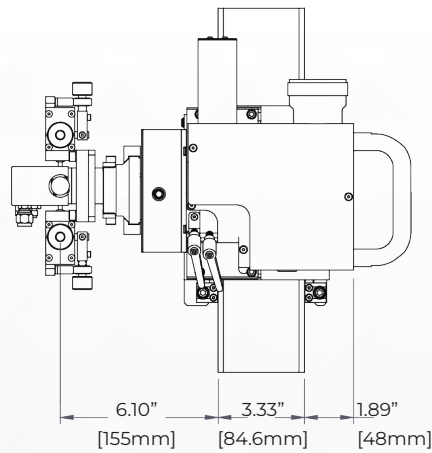
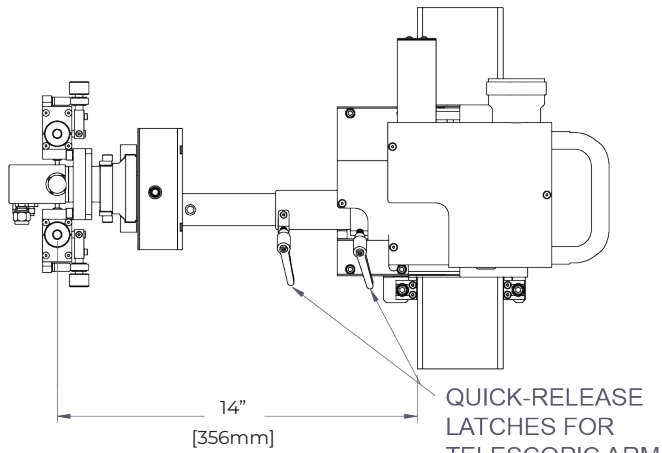

■ Specifications

- Travel speed: 0 to 20IPM [0.5m/min]
- Arc Voltage Control (AVC) stroke: 1.5" [38mm]
- Manual vertical torch adjustment: 3.5" [89mm]
- Torch oscillation/steering stroke: 1.9" [48mm]
- Telescoping torch extension: 0" to 6" [152mm]
- Torch tilt, lead/lag: +/-15 degrees
- Torch tilt, in/out: +/- 15 degrees
- Cable length: 35ft [11m]
- Weight: 25lbs [11kg] (without cable or wire)
- OD welding range: 2" [51mm] to infinity
- ID welding range: 20" [51cm] to infinity (requires ID adapter kit)
- Wire size range: 0.030" [0.8mm] to 0.062" [1.6mm]

■ Features

- Wire feeders: 100IPM [2.5m/min] or 400IPM [10m/min], single or dual
- Wire spools: 4" [101.6mm] or 8" [203.2mm], single or dual
- Wire nozzle adjustment (up/down, left/right), manual or motorized

■ Options

- Torch configurations: Conventional, NG Blade, NG Flood Cup
- Hot Wire
- Water cooled weld monitoring cameras
- ID adapter kit
- Wire straightener
- Extension cables
- Extended AVC
- Tilt axis