

HEMISPHERIX AS, A20 & SPS
INSTALLATION GUIDE



Congratulations on choosing Krix

Your Krix speakers are designed to reproduce the highest quality sound. To get the best performance from your speakers please read these installation instructions thoroughly as there are many factors that influence the performance of your speakers. If you have any difficulties please contact one of our friendly authorised Krix dealers.

SETUP IN BRIEF

The following setup procedure will help you gain the best performance from your in-ceiling speaker:

1. Unpacking

Remove your speaker from the packaging

2. Introduction

Learn about the Hemispherix AS, Hemispherix A20 and Hemispherix SPS

3. Before you begin

Determine a suitable location for your speakers

4. Installation

Cut mounting hole, connect cabling and install speaker

5. Listen and enjoy

Listen to your favourite music/movies and enjoy

Disclaimer

Drilling into anything can be dangerous. You should make sure you know what is behind or inside the surface that you are drilling before you start to drill. For example, you might strike an electrical cable.

You must install the speaker securely to the surface that you are fixing it to. If you don't, injury or damage may occur.

If you do not feel entirely confident about installing this product, contact a professional installer.

To the extent permissible by law:

All warranties, conditions, representations, promises and statements relating howsoever to this product whether express or implied and whether in contract or tort are excluded to the extent permitted by law; and

Our liability to you under a condition or warranty (if any) implied into this sale and purchase agreement relating to these brackets by the Trade Practices Act 1974 (as amended) or any other law (whether a law of Australia or any other country) other than a condition implied by Section 69 of the said Act is limited at our option to:

the replacement of the product; or

the supply of an equivalent product; or

the repair of the product.

If you do not accept the above conditions, return this product (in the original packaging) with proof of purchase for a full refund.

INTRODUCTION

Introduction

The Hemispherix AS and A20 are in-ceiling loudspeakers featuring fully sealed back-boxes to control and maximise bass response, whilst keeping out dust and other ceiling inhabitants.

The Hemispherix A20 employs an acoustically optimised front baffle angled at 20 degrees, allowing its sound output to be projected towards your primary listening area.

The Hemispherix AS employs a flat front baffle for uniform sound coverage in all directions

The Hemispherix SPS features a stereo pair of inputs and a slim semi-open back box, providing a stereo effect from a single source (figure 1).

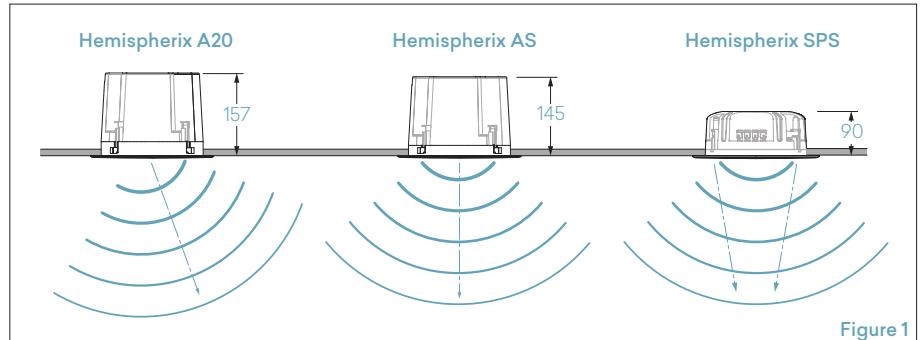

Figure 1

Applications best suited to Hemispherix AS

The wide uniform coverage of the Hemispherix AS makes it the ideal choice for 2 channel stereo and background music applications. Its uniform coverage is ideally suited to any applications where the listening area is not confined to a specific part of the room. For example, hallways, dining rooms, office spaces, bedrooms and multipurpose rooms (figure 2).

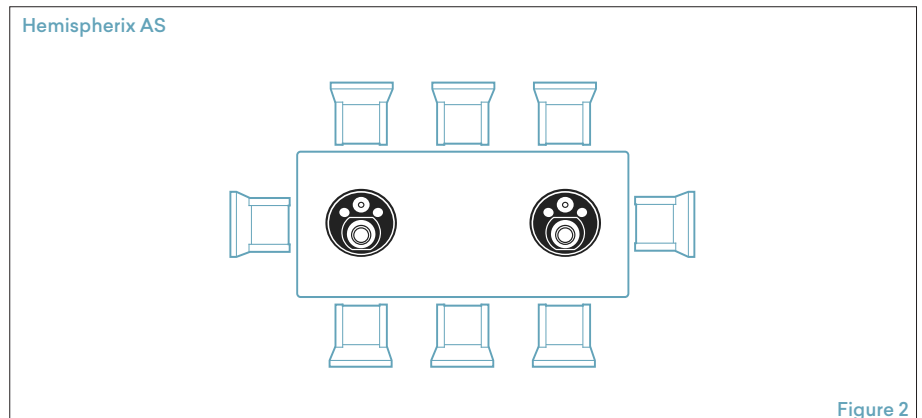

Figure 2

Applications best suited to Hemispherix A20

The ability of the Hemispherix A20 to project sound toward your primary listening area makes it ideally suited to home cinema applications (figure 3). Dialogue will become more articulate, music will have better definition and surround effects will become more involving and realistic. The A20's ability to direct more sound towards the listener results in less sound reflecting off walls and other surfaces in the room, creating a clearer, more three dimensional soundstage. The A20 may also be useful for background music applications where the speaker must be placed near a side wall for aesthetic or structural reasons. In this application the A20 can be used to project the sound towards the centre of the room.

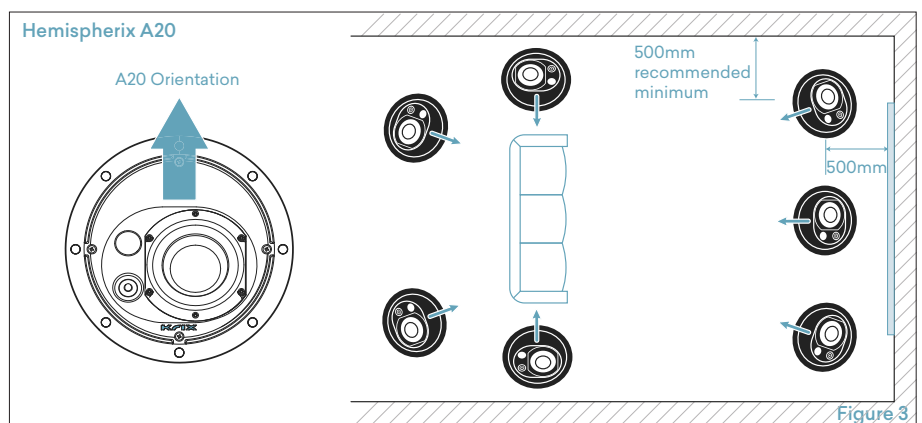

Figure 3

Applications best suited to Hemispherix SPS

The Hemispherix SPS is perfect in small rooms where there is difficulty fitting a stereo pair of loudspeakers (figure 4). It can also be used where there is limited ceiling height.

If desired, two Hemispherix SPS loudspeakers may be wired together in parallel, or a single Hemispherix SPS may have both inputs wired in parallel from a single output.

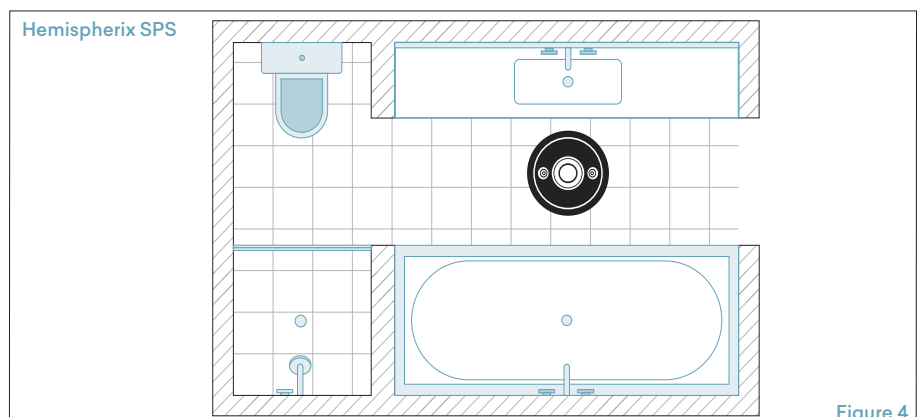

Figure 4

INSTALLATION

Before you begin

⚠ Please read the disclaimer on page 2 of this manual.

- To determine the best location for your loudspeakers, refer to page 3 of this manual and discuss with your local Krix dealer, or installation consultant. Be sure to check for any obstructions, such as electrical wiring, plumbing, stud work or air conditioning ducts before commencing the installation (figure 5).

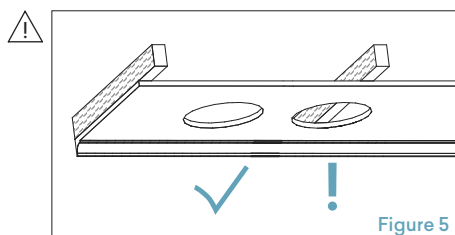

- Also ensure that there is enough ceiling/wall space to accommodate the speaker enclosure.

Connecting

To ensure optimum performance, it is important that your speaker system is connected properly:

⚠ Turn off all electronic equipment and disconnect from the power point.

- Follow the connection instructions supplied with your amplifier and media player.
- Install speaker cable in the wall or the ceiling cavity. Allow approximately 300mm of excess cable to facilitate the loudspeaker installation.
- Follow the connection instructions supplied with your amplifier to connect the speaker cables to amplifier. Take care to assign the same cable colour or trace to the positive (+) connector on the amplifier as the positive (+) connector on the speaker.
- Prepare the speaker cables for connecting to speakers by neatly stripping the cable ends.

Care should be taken to eliminate loose strands of wire that may present a short circuit hazard.

Installation

- Once the correct placement has been determined, use the cardboard insert marked 'template' (from the internal packing) to trace the required cut-out onto the ceiling/wall (figure 8).
- Drill a hole inside the marked cut-out. Using a fine gyprock saw, cut around the inside of the marked cut-out (figure 9).
- Remove the circular offcut and insert the speaker to check the hole is the correct size. Enlarge the cut-out if required.

⚠ **Hemispherix A20 only:**
Determine the correct orientation for your speaker. It is recommended that the Krix logo is aimed towards your primary listening area for best results (figure 3).

- Pull the stripped speaker cable through the ceiling/wall opening. Push and hold down the positive (+) red binding post on the speaker and insert the positive (+) wire through the hole in the post. Take care to assign the same cable colour or trace to the positive (+) connector on the amplifier, as the positive (+) connector on the speaker. Repeat the connection process with the negative (-) black binding post and the negative (-) wire (figure 10).
- Ensure all the mounting clamps are turned back against the speaker enclosure (figure 10), so that the speaker can be easily inserted into the ceiling cut-out. Once the speaker has been located in the ceiling/wall, use a Phillips head screwdriver to tighten all the mounting screws. As the screws are tightened, the mounting clamps will automatically swing out over the plaster board and clamp the speaker in place. Be careful not to overtighten the screws, as this may strip the clamp, or crush the plaster board surface (figure 11).
- The Hemispherix AS features a pivoting tweeter which allows the high frequency sound to be directed as desired. Gently press on the round outer edge of the tweeter frame to tilt the tweeter to the desired position. Be careful not touch the tweeter diaphragm, as this may damage the tweeter (figure 12).
- Gently fit the magnetic grille to the front of the speaker housing (figure 13).

Painting

- If the speaker grille requires painting it is recommended to use a spray can for ease of application. Alternatively, it is possible to apply acrylic or enamel paint using a small foam roller but this will require more applications to achieve a good result.

Spray can application

- Use a spray can to apply a light coat of paint. Rotate the product at 90° intervals and apply three more light coats to ensure an even coverage (figure 6).
- Be careful in applying single heavy coats of paint as there is a higher probability of blocking the holes in the grille. If the grill does become blocked by paint, use a small pin or similar to release the blockage, while the paint is still wet.

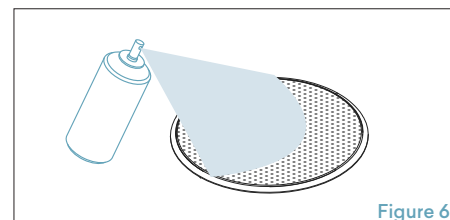

Roller application

- Load a foam roller with a light coverage of thin paint and then roll onto the grille. Try to avoid blocking the holes in the grille. If the grille does become blocked by paint, use a small pin or similar to release the blockage, while the paint is still wet.
- Allow the paint to dry. Apply three or more light coats to ensure an even coverage (figure 7).

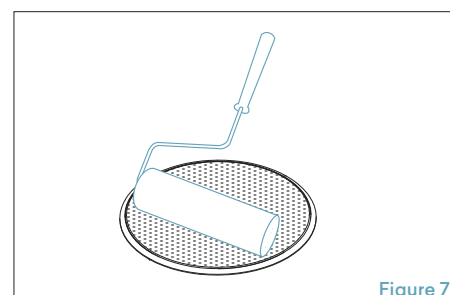

INSTALLATION

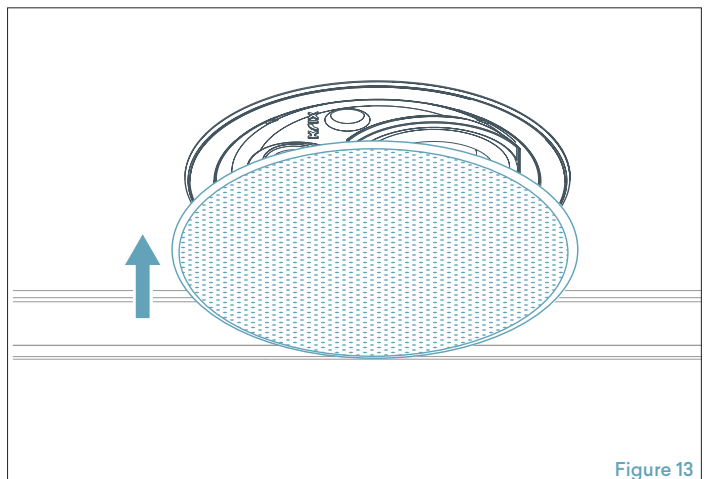
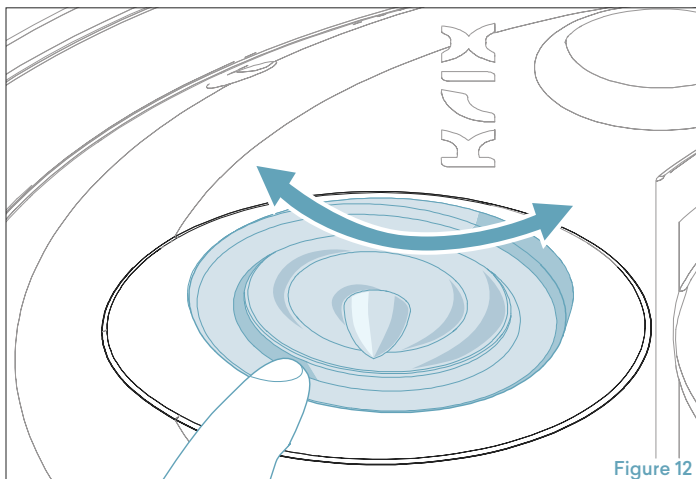
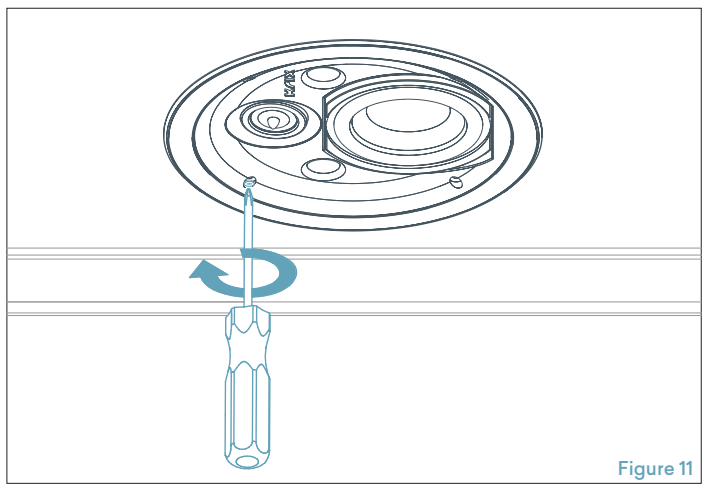
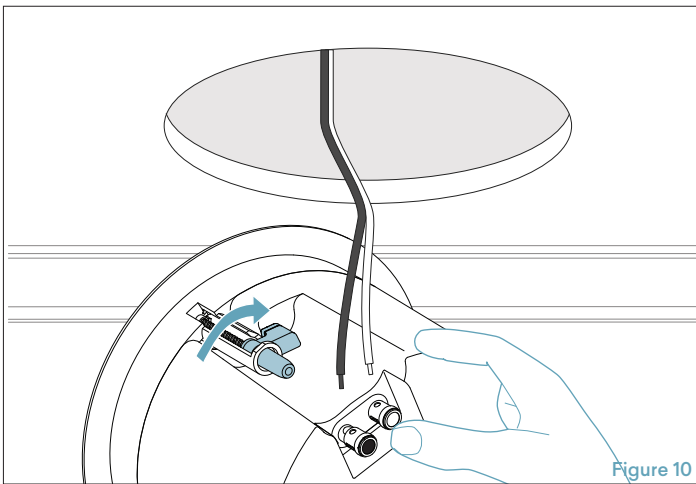
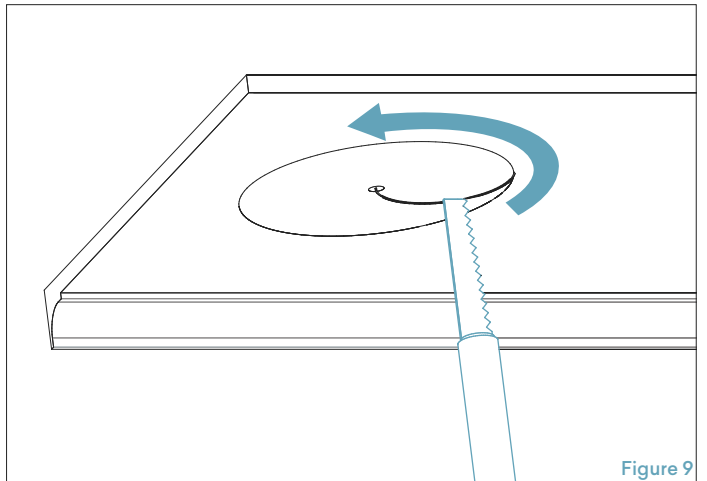
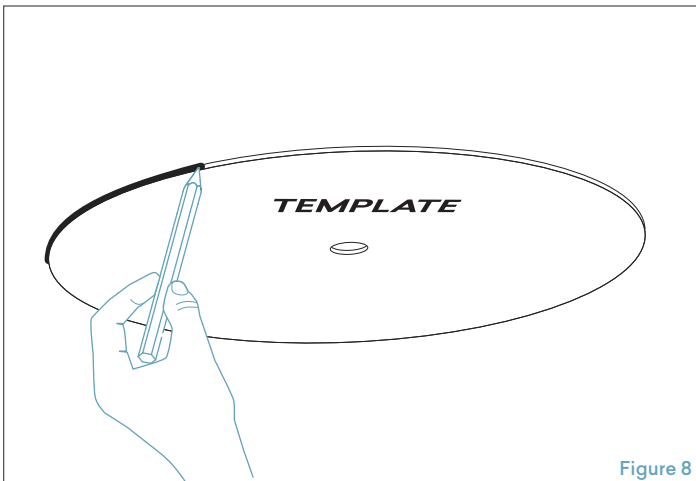

SPECIFICATIONS

Warranty

Lifetime limited warranty applies to the cabinet and speaker.

(Refer to the details on the warranty card supplied)

Queries

If you have any queries regarding the Hemispherix or any other Krix product, please contact your nearest Krix dealer or Krix directly. Contact details are on the back cover of this booklet.

Hemispherix AS

Frequency range	65Hz - 40kHz in room response
Power handling	20-100 watts RMS recommended amplifier power
Sensitivity	86dB for 2.83 volts at 1 metre
Configuration	2-way
Bass Driver(s)	Nominal 100mm (4") doped paper cone. 25mm (1") voice coil wound on high temperature Kapton former
Tweeter	20mm (¾") ring radiator, adjustable 'eyeball'
Crossover Points	2.1kHz
Impedance	Nominally 6 ohms (minimum 4.2 ohms)
Enclosure Type	Bass reflex, front vented
Dimensions	255mm diameter x 145mm mounting depth
Mounting cut-out diameter	207mm
Finish	White (can be painted to match your décor)
Input Terminals	Push type connectors
Weight	2kg each

Hemispherix A20

Frequency range	65Hz - 40kHz in room response
Power handling	20-100 watts RMS recommended amplifier power
Sensitivity	86dB for 2.83 volts at 1 metre
Configuration	2-way with 20° angle
Bass Driver(s)	Nominal 100mm (4") doped paper cone. 25mm (1") voice coil wound on high temperature Kapton former
Tweeter	20mm (¾") ring radiator
Crossover Points	2.1kHz
Impedance	Nominally 6 ohms (minimum 4.2 ohms)
Enclosure Type	Bass reflex, front vented
Dimensions	255mm diameter x 157mm mounting depth
Mounting cut-out diameter	207mm
Finish	White (can be painted to match your décor)
Input Terminals	Push type connectors
Weight	2kg each

SPECIFICATIONS

Hemispherix SPS

Frequency range	70 Hz - 40 kHz in room response
Power handling	5-50 watts RMS recommended amplifier power per channel
Sensitivity	85 dB for 2.83 volts at 1 metre
Configuration	Dual 2-way
Bass Driver(s)	1 x 125mm (5") polypropylene cone, 35mm dual voice coil
Tweeter	2 x 20mm (¾") ring radiator
Crossover Points	2.4 kHz
Impedance	Nominally 8 ohms per channel (Minimum 6.4 ohms)
Enclosure Type	Semi-open back
Dimensions	255mm diameter x 90mm mounting depth
Mounting cut-out diameter	207mm
Finish	White (can be painted to match your décor)
Input Terminals	Push type connectors
Weight	1.8 kg each

Krix Loudspeakers Pty Ltd
14 Chapman Road
Hackham SA 5163
Australia

T 61 8 8384 3433
F 61 8 8384 3419
listen@krix.com

Rev #10003

krix.com