

PWR	
DT13-08PA	
1	B+
2	KSW
3	CAN_L
4	CAN_H
5	SWG1
6	SWG2
7	SWG3
8	B-

DETAIL A
SCALE 1.5 : 1

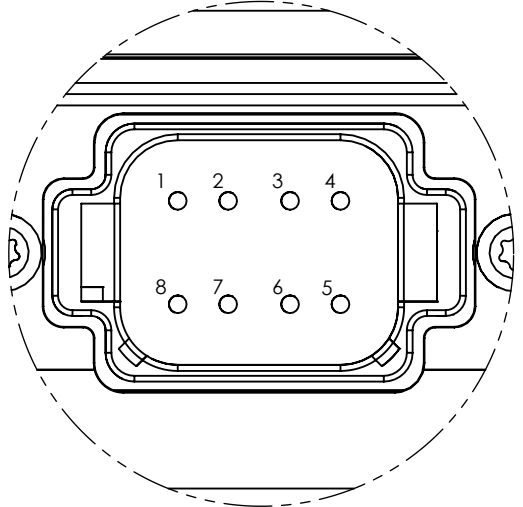

T1 CONNECTOR 2325088-1	
1	T+
2	T-

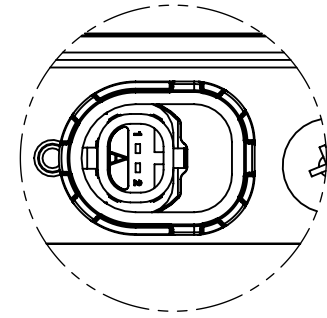

DETAIL B
SCALE 1 : 1
960-00236-2 ONLY

ENET	
M12-X/F	
1	A+
2	A-
3	B+
4	B-
5	D+
6	D-
7	C-
8	C+

DETAIL C
SCALE 3 : 1

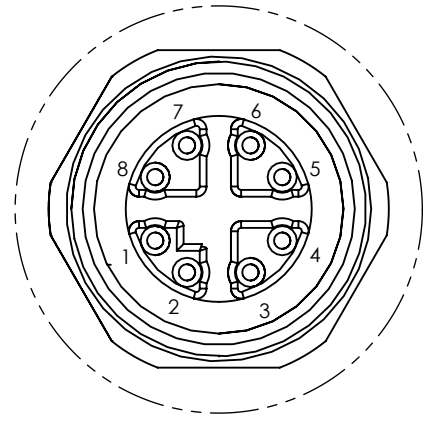

REVISION HISTORY			
REV	DESCRIPTION	DATE	APPROVED
A	INITIAL RELEASE	2022-04-22	MPD

DETAIL D
SCALE 2 : 1

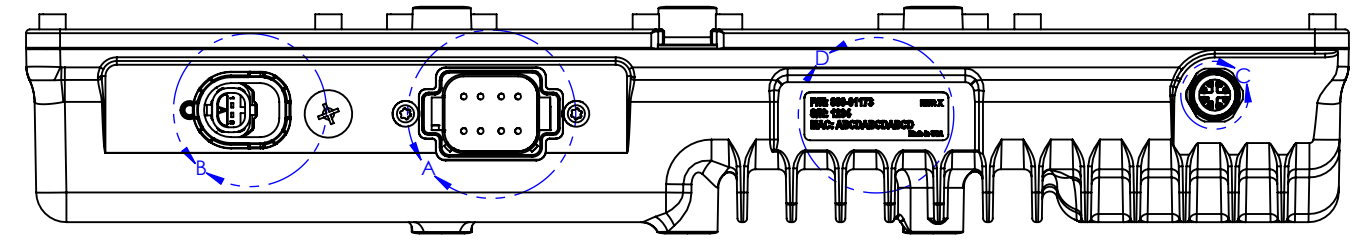
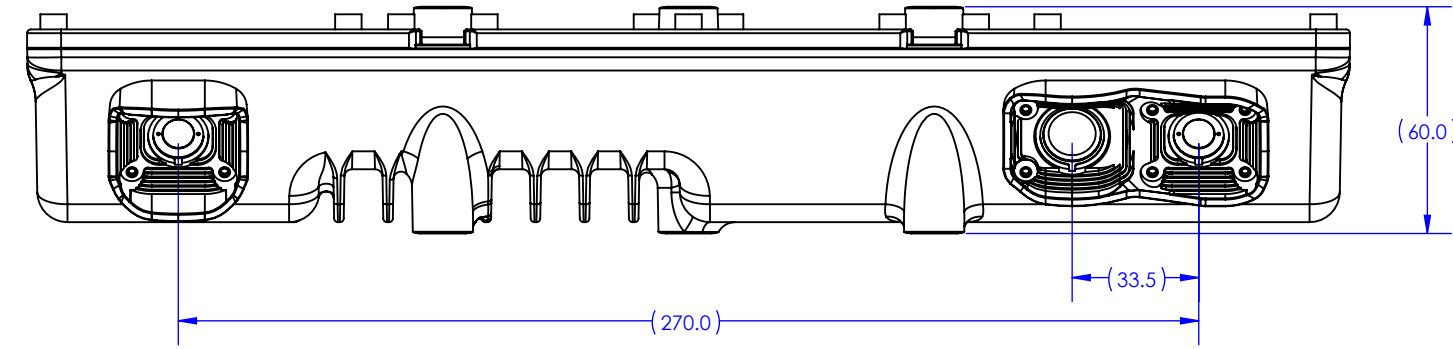
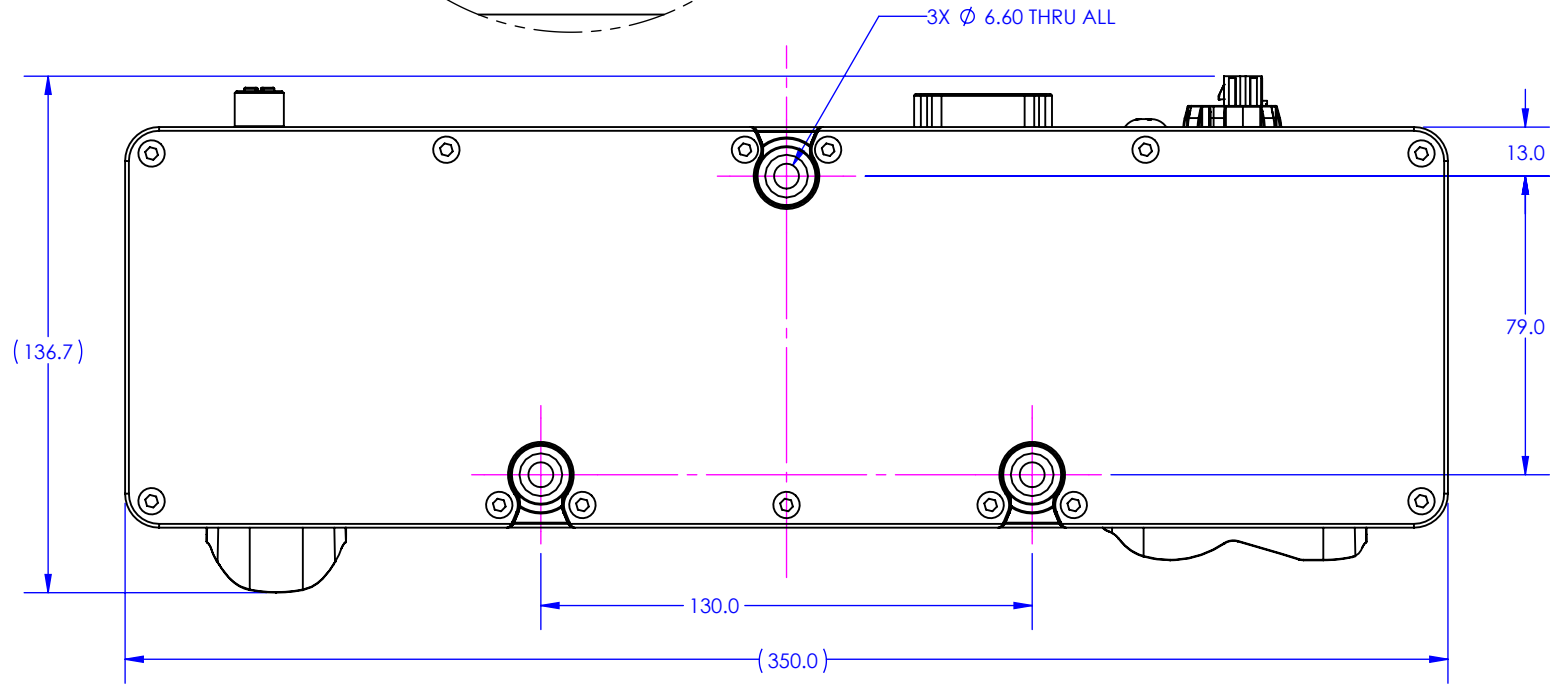
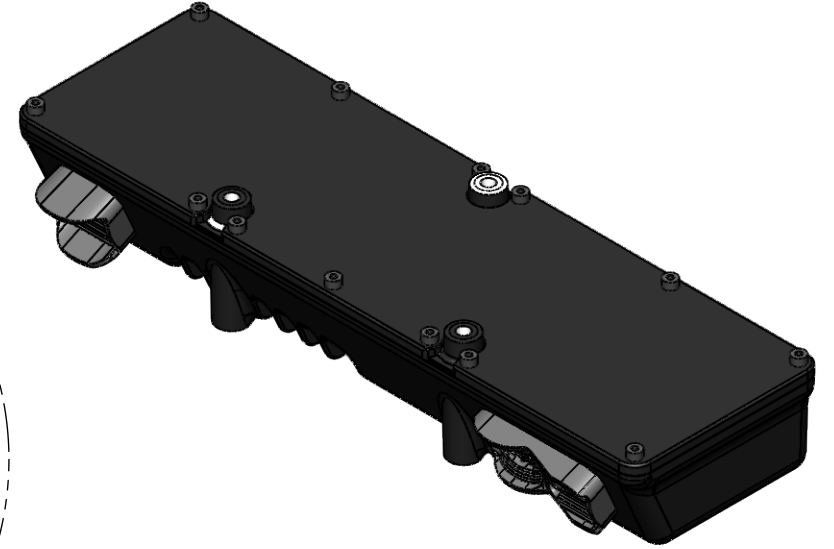
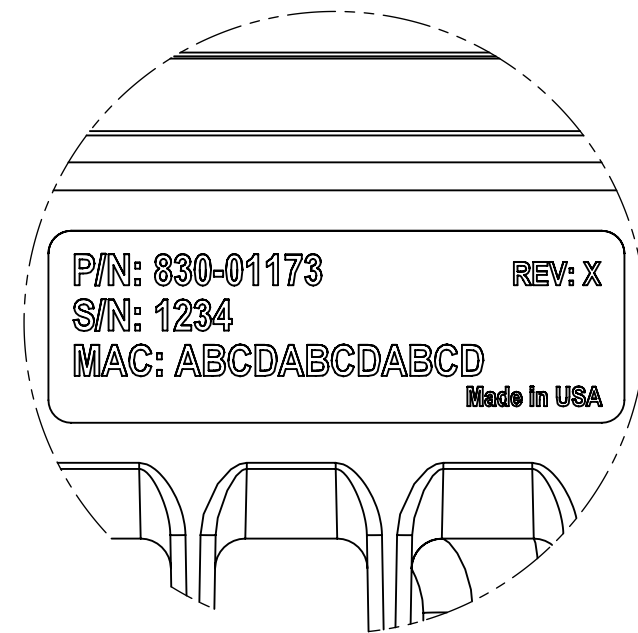

ITEM NO.	QTY.	TOP LEVEL PART NUMBER	TOP LEVEL DESCRIPTION	PART NUMBER	DESCRIPTION
1	1	960-00236-2	ICD, GENERIC S27, GIGABIT	830-01173-2	ASSY, STEREO, 27CM, 3CAM, ZU5, GIGABIT, GENERIC
1	1	960-00236-5	ICD, GENERIC S27, GIGABIT, NO T1	830-01173-5	ASSY, STEREO, 27CM, 3CAM, ZU5, GIGABIT, NO T1, GENERIC

NOTES (UNLESS OTHERWISE SPECIFIED):

- WEIGHT: ~2.1 KG
- COLOR: BLACK
- STEREO LENS FOV: 91° HFOV, 54° VFOV
- COLOR LENS FOV: 137° HFOV, 83° VFOV
- INPUT VOLTAGE: 9-48 VDC
- OPERATING TEMP: -40~85 C
- ENVIRONMENTAL SEALING: IP67

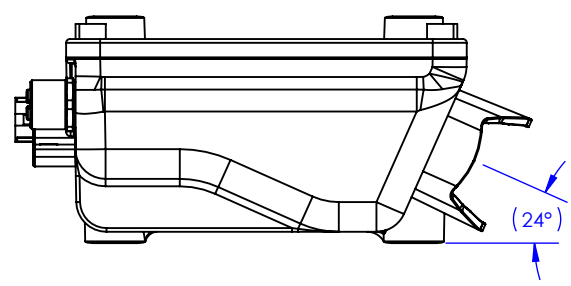

Carnegie Robotics
4501 HATFIELD STREET
PITTSBURGH, PA 15201
CARNEGIEROBOTICS.COM
CAGE CODE: 4QND3

THE INFORMATION CONTAINED IN THIS DRAWING IS THE SOLE PROPERTY OF CARNEGIE ROBOTICS LLC. ANY REPRODUCTION IN PART OR AS A WHOLE WITHOUT THE WRITTEN PERMISSION OF CARNEGIE ROBOTICS LLC IS PROHIBITED.

	ENGR	DATE
DRAWN	DR	2022-02-18
CHECKED	MD	2022-05-05
ENGR	DR	2022-02-18
APPROVED	MD	2022-05-04

UNLESS OTHERWISE SPECIFIED DIMENSIONS ARE IN MILLIMETERS
TOLERANCES: ANGULAR ± 0.5° SURFACE FINISH: 1.6
X ± 1.3
X.X ± 0.5
X.XX ± 0.13

ICD, GENERIC S27

SIZE B	PART NUMBER 960-00236	REV A
MATERIAL N/A	FINISH N/A	DO NOT SCALE
SHEET 1 OF 1		