

AC POWER CONTROLLERS

Your passengers want and need the convenience of 115VAC or 230VAC electrical power in the cabin to remain productive, use and recharge their Personal Electronic Device (PEDs) or just provide a more enjoyable and entertaining in-flight experience.

Mid Continent Controls offers a Cabin AC Power System that is specifically designed to operate within the aircraft environment. This system can be installed with optimal GFIs, power controllers and AC outlets to accommodate either 115VAC or 230VAC depending on aircraft requirements.

Mid Continent Controls' AC Power Controllers manage the distribution of AC power to outlets within the aircraft. AC outlets are supplied with electrical current only when a plug has been inserted into the outlet. Once the plug is removed, the Power Controller halts the flow of current to the outlet. Our power controllers also control the amperage delivered to outlets. These power controllers are offered in multiple configurations of inputs, outputs and amperage ranges.

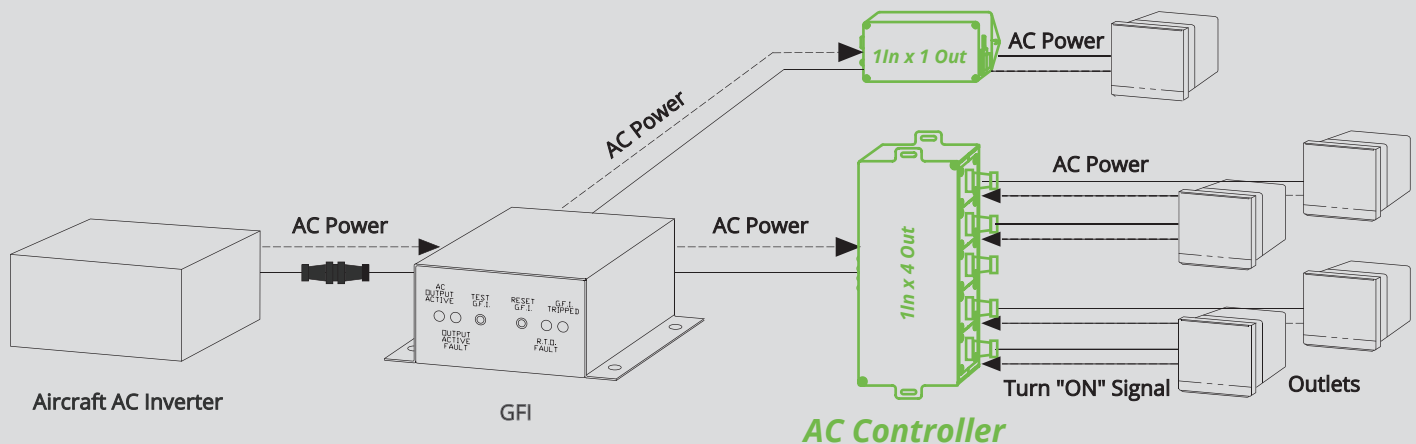

AC POWER CONTROLLERS

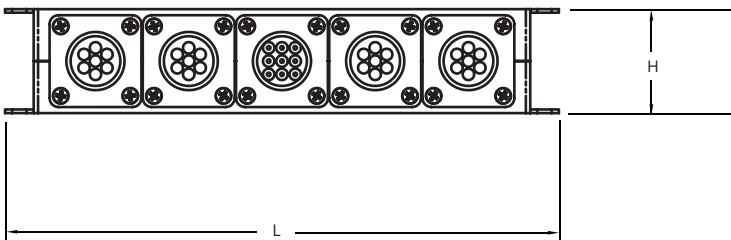
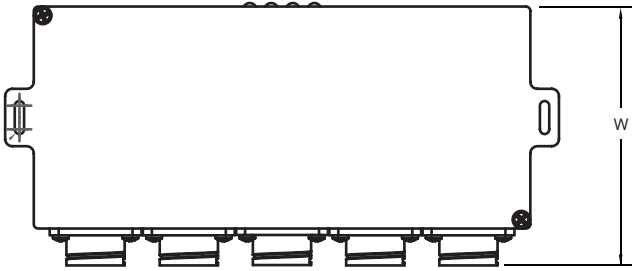

Part Number..... 106282 Series
 Power Distribution..... 1 In x 4 Out
 Case Size..... 3.61 (W) x 7.72 (L) x 1.45 (H)
 NTE Weight..... 14oz
 DC Power Input..... 28VDC
 DC Circuit Breaker (Recommended)..... 1A
 AC Voltage..... 115VAC/230VAC
 AC Current Max Input..... 15A
 106282-1 (Each Output Internally Limited)..... 115VAC@5A, 230VAC@3A
 106282-2 (Each Output Internally Limited)..... 115VAC@3A, 230VAC@.45A
 106282-3 No Internal Current Limit, External Limit
 106282-4 (Each Output Internally Limited)..... 115VAC@2A, 230VAC@1A

Part Number..... 106350 Series
 Power Distribution..... 1 In x 4 Out
 Case Size..... 4.94 (W) x 7.72 (L) x 1.45 (H)
 NTE Weight..... 19oz
 DC Power Input..... 28VDC
 DC Circuit Breaker (Recommended)..... 1A
 AC Voltage..... 115VAC/230VAC
 AC Current Max..... 15A
 106350-1 (Each Output Internally Limited)..... 115VAC@2A, 230VAC@1A
 106350-2 (Each Output Internally Limited)..... 115VAC@3A, 230VAC@1.5A

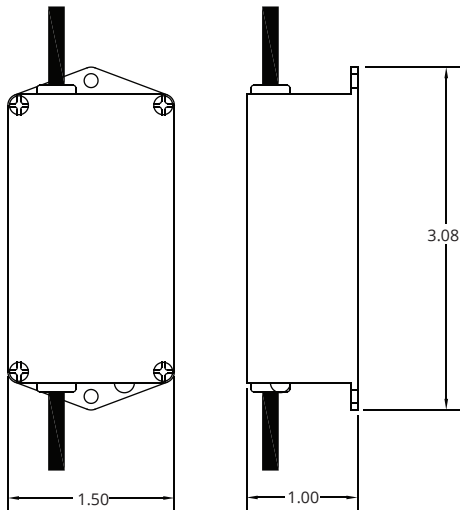

Part Number..... 106070-1
 Power Distribution..... 1 In x 1 Out
 NTE Weight..... .5oz
 DC Power Input..... 28VDC
 AC Voltage..... 115/230VAC
 AC Current Maximum..... 5A

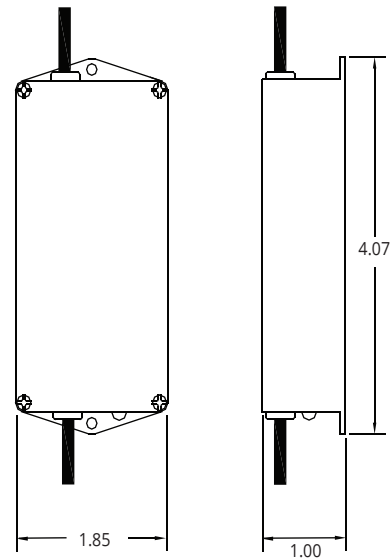

Part Number..... 106075-1
 Power Distribution..... 1 In x 1 Out
 NTE Weight..... .9oz
 DC Power Input..... 28VDC
 AC Voltage..... 115/230VAC
 AC Current Maximum..... 15A