



 **FORGE/os 5**
UR CB-Series Startup Guide



The documentation, best practices, and recommendations provided by READY Robotics do NOT constitute safety advice. Products sold through READY Robotics are not by themselves a fully integrated workcell. As required in ISO 10218-2, READY Robotics strongly recommends performing a complete risk assessment of the integrated workcell per ISO 12100. You may wish to use the methodology found in the ANSI/RIA TR R15.306 Task-based Risk Assessment Methodology.

CONTENTS

- Overview 4
- Hardware Requirements 5
- Software Requirements 7
 - Confirming Software Requirements 8
- Connecting the UR Control Box 10
- Connecting the READY pendant 15
- Powering On 20
- Preparing Polyscope on a CB-Series Robot 21
- Signing In to Forge/OS 26
- Transferring Configuration Files 28
- Adding the UR Robot in Device Configuration 35
- Appendix A: Setting Up Forge/OS 39
 - Installing Forge/OS 39
 - Activating Forge/OS with a License Code 48
 - Choosing Preferences 51
- Resources 53

OVERVIEW

This document walks you through setting up your CB-Series Universal Robot and Forge/OS 5.

You will complete the following steps:

1. Connect your IPC to the UR Control Box.
2. Connect your UR robot to the UR Control Box.
3. Connect the READY pendant to the UR Control Box.
4. Power on the system.
5. Install a supported Polyscope version and set the robot's IP address on the UR pendant.
6. Install and set up Forge/OS.
7. Add your robot in the Device Configuration app on the READY pendant.



Note: This document assumes that you have mounted your robot following UR guidelines. You can find their documentation at universal-robots.com/download/.

HARDWARE REQUIREMENTS







Image	Part Name	Description	Vendor	Part Number
	Industrial PC (IPC)	Hosts Forge/OS. Note: Refer to the Forge/OS 5 User Manual for IPC requirements.		
	READY pendant	The touch screen interface for Forge/OS.	READY Robotics	112563
	UR Teach Pendant and Control Box	Powers and controls the robot (pendant required to up Forge/OS).	Universal Robots	-
	UR Control Box Key	Opens the UR Control Box.	Universal Robots	-
	Cat5e Bulkhead Ethernet Connector	Attaches at the base of the UR Control Box to connect two Ethernet cables.	Mouser	1546413-3

Image	Part Name	Description	Vendor	Part Number
	<p>Cat5e STP Ethernet Cable (x3)</p>	<ul style="list-style-type: none"> ▪ Routes from the internals of the UR Control Box to the Cat5e Bulkhead Ethernet Connector. ▪ Routes from the Cat5e Bulkhead Ethernet Connector to the IPC. ▪ Connects the READY pendant to the IPC. 		
	<p>Ethernet Bulkhead Dust Cover</p>	<p>Protects the Cat5 Bulkheads Ethernet Connector when the outside Ethernet Cable is not plugged in.</p>	<p>Mouser</p>	<p>1-1546406-1</p>
	<p>Cable Gland</p>	<p>Provides strain relief for safety cabling going into the UR Control Box</p>	<p>Automation Direct</p>	<p>BSPAX-11-W</p>

SOFTWARE REQUIREMENTS

The native UR software that runs on the UR Teach pendant is called **Polyscope**. Refer to the table below for the Polyscope version requirement.

Controller	Minimum Software Version
CB-Series (all robots)	3.14.3

Important: *If the robot controller is not running the minimum supported Polyscope version, it will not communicate with Forge/OS.*

CONFIRMING SOFTWARE REQUIREMENTS

Follow these steps to check the software version on a UR robot controller.

- 1 Power on your UR controller.
- 2 On the UR teach pendant, go to the **About** page.

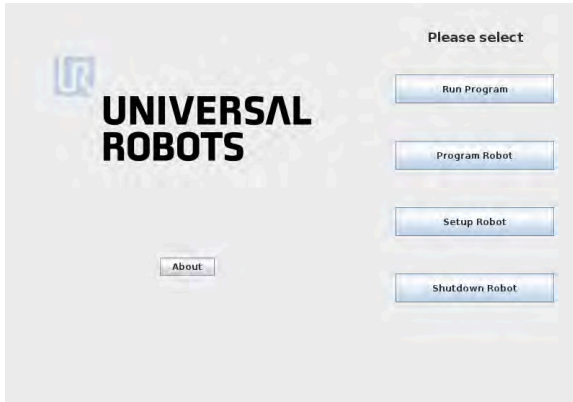

CB-Series: About Button (on Home Screen)

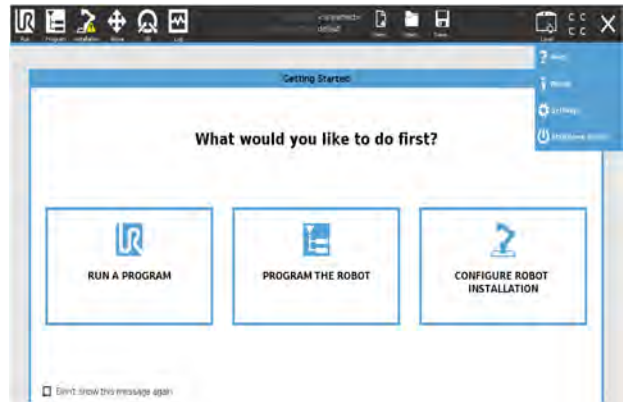

e-Series: About Button (in Hamburger Menu)

- 3 In the **Version** tab, look for the **Universal Robots Software** version.



CB-Series: Version Tab



e-Series: Version Tab

- 4 If your UR software is older than the requirement, download an update at Universal Robots Support site: www.universal-robots.com/articles/ur/documentation/all-legacy-download-center.

Note: *If you have a CB-Series robot with an old Polyscope version, you may need to update sequentially before jumping to the latest version. Refer to UR guidelines for more info.*

CONNECTING THE UR CONTROL BOX

- 1 Open the UR Control Box by inserting the controller key and turning it clockwise.

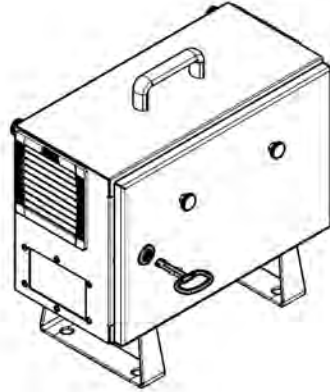

- 2 Remove the nut on the Cat5 Bulkhead Ethernet Connector.

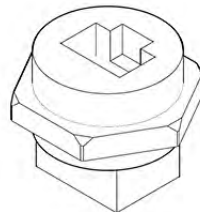

- 3 Place the Dust Cover's loop over the connector and seat it against the gasket.

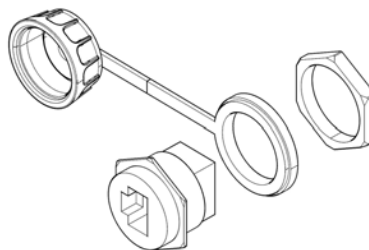

- 4 At the bottom of the UR Control Box, remove one of the rubber plugs or metal knockouts.

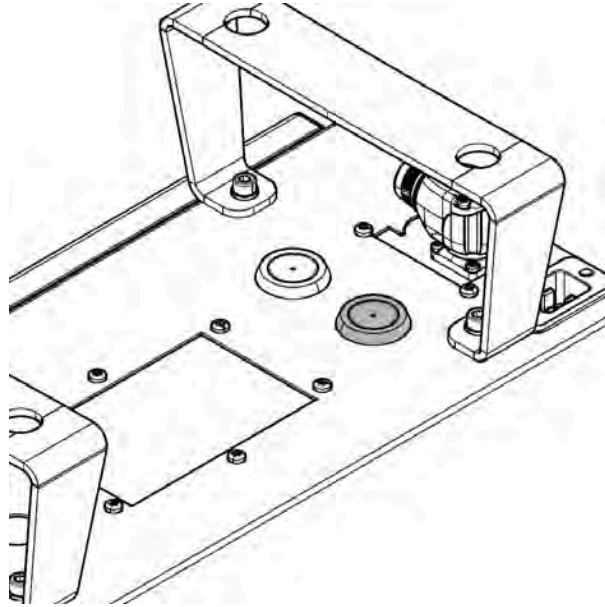

- 5 Insert the silver side of the Ethernet Connector into the hole.

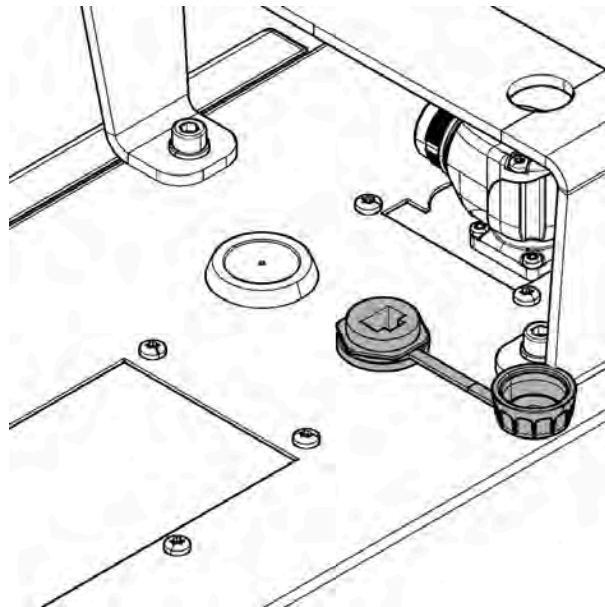

- 6 Find the nut that you removed from the Ethernet Connector. Screw the nut onto the Connector until it is hand-tight against the Control Box wall.

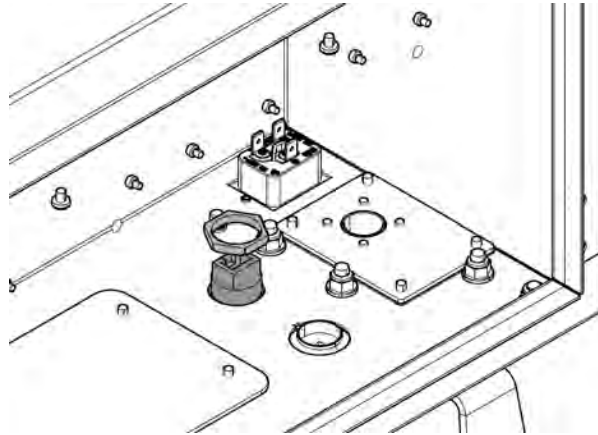

- 7 Plug the shorter Ethernet cable into the Ethernet Connector.

- 8 Plug the other end of the cable into the Ethernet port in the UR controller.

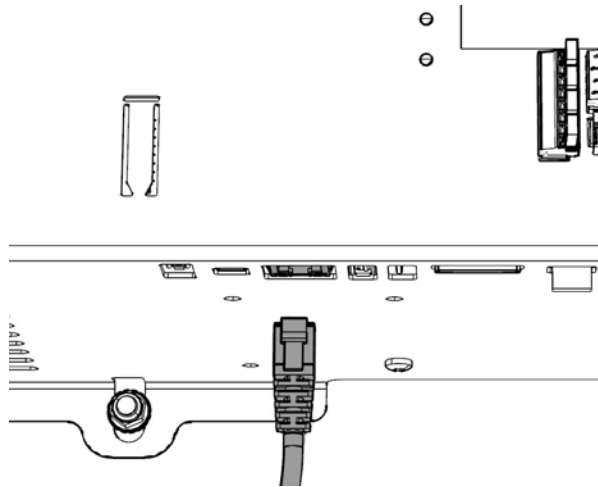

- 9 Plug one end of the longer Ethernet cable into the outside end of the Ethernet Connector.

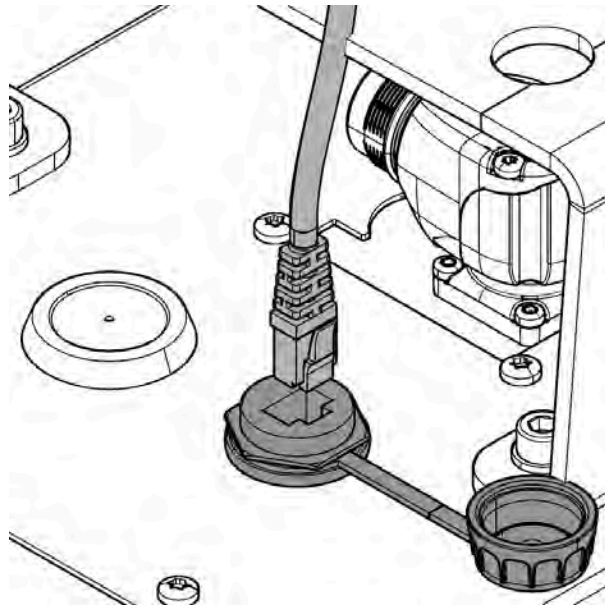

10 Plug the other end of the Ethernet cable into a **LAN** port on your IPC.

11 Plug the robot's cable connector into the metal socket at the base of the UR Control Box. Push the cable against the socket and turning the collar clockwise.

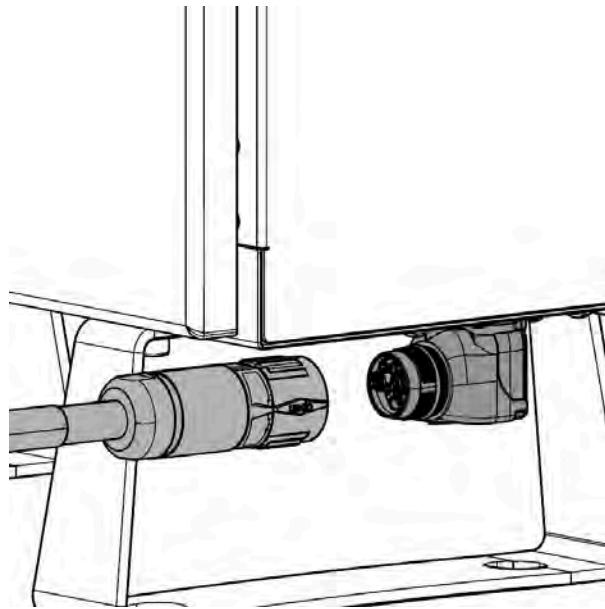

- 12 Plug the UR control box power cable into the port at the base of the UR Control Box. Do not plug the controller into a power source yet.

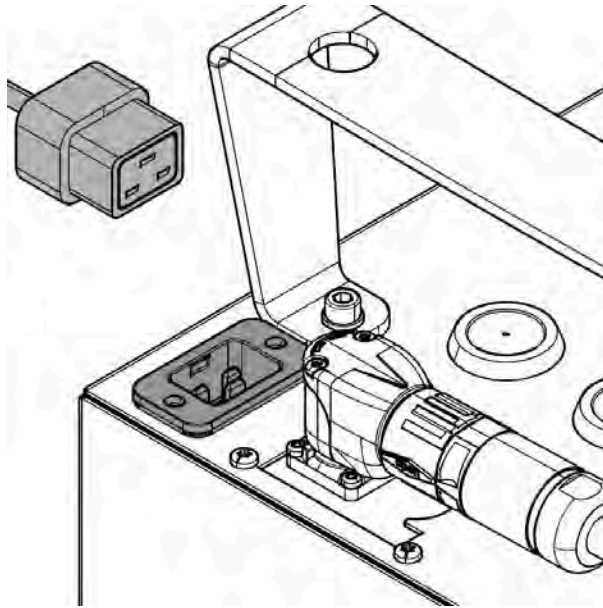

CONNECTING THE READY PENDANT

The READY pendant includes these safety outputs:

1. Key Switch (Robot Operation Mode)
2. Three-Position Enabling Switch
3. Emergency Stop Button



The end of the READY pendant cable includes:

1. One RJ45 Ethernet cable for communication with the IPC.
2. 15 Flying leads—2 for power, 12 for safety I/O, and 1 unused lead.

Note: You'll connect the **READY pendant** Emergency Stop to the UR controller. The UR robot won't use the **READY pendant** key selector switch or the three-position enabling switch. You can connect the three-position enabling switch if you configure Polyscope to use an enabling device.



Electric Shock Warning: Disconnect all components from power sources before attempting this installation.

- 1 Open the UR Control Box by inserting the controller key and turning it clockwise.

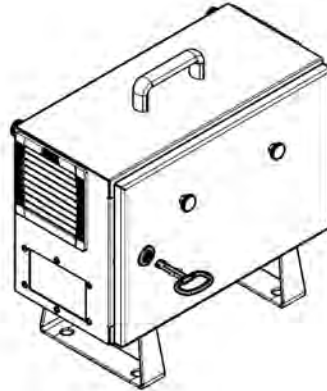

- 2 Remove an unused knockout on the bottom of the UR Control Box.

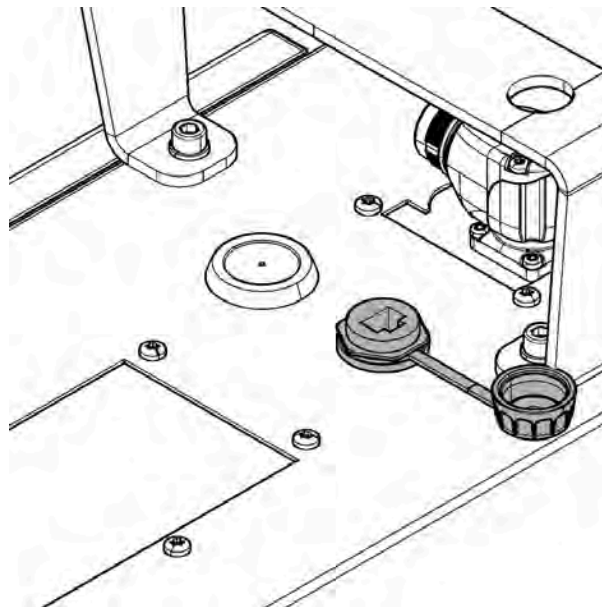

- 3 Insert a cable gland into the hole.

Note: This cable gland will maintain IP rating and provide strain relief to the safety cable.

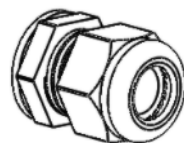

4 Route the READY pendant flying leads to the UR Control Box. Follow the diagram and table below.

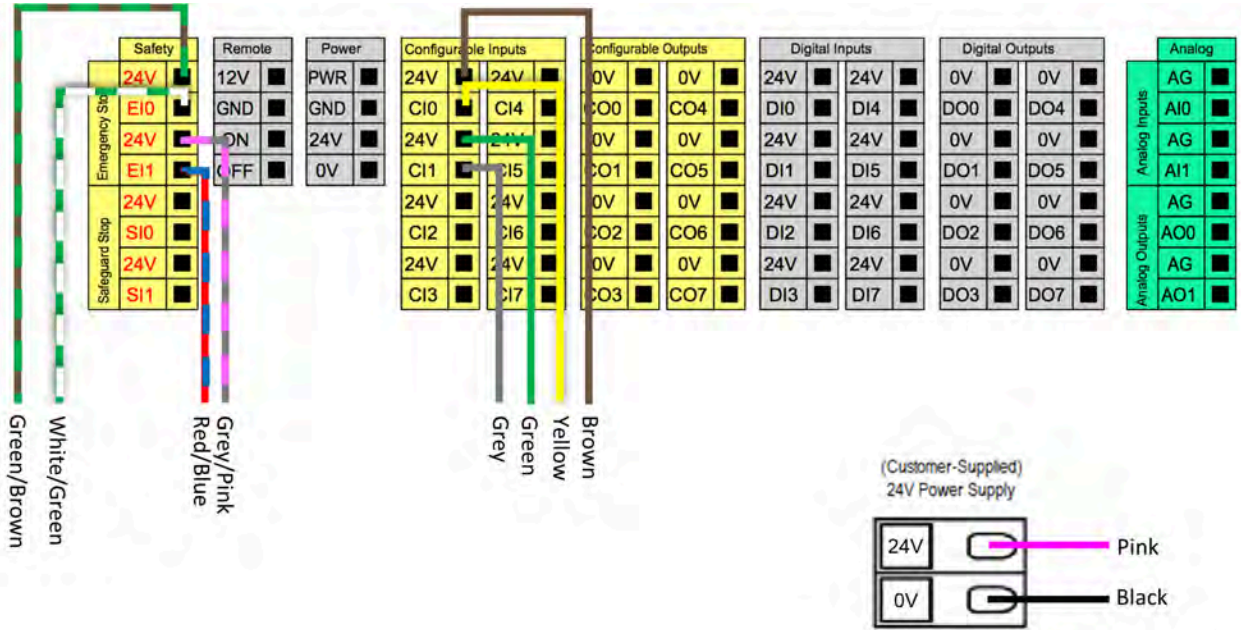

Pendant Cable	Safety Block	Configurable Input Block	Exterior 24V Power Supply	Function
Brown		(Optional) 24V		Enabling Switch Circuit 1
Yellow		(Optional) CI0		Enabling Switch Circuit 1
Green		(Optional) 24V		Enabling Switch Circuit 2
Gray		(Optional) CI1		Enabling Switch Circuit 2
Pink			24 VDC	24 VDC
Green/ Brown	24V			Emergency Stop Circuit 1
White/Green	EI0			Emergency Stop Circuit 1
Gray/Pink	24V			Emergency Stop Circuit 2
Red/Blue	EI1			Emergency Stop Circuit 2
Black			0 VDC	0 VDC
Violet				Key Switch Circuit 1 (NC)
White/Pink				Key Switch Circuit 1 (NC)
White				Key Switch Circuit 2 (NC)
Blue				Key Switch Circuit 2 (NC)
White/Blue				NC

Note: Leave the Safeguard Stop terminals jumpered if you're not using them. Make sure the **SI0** terminal is jumpered to the **24V** terminal above it and the **SI1** terminal is jumpered to the **24V** terminal above it.

- 5 Close the UR Control Box and turn the key counterclockwise to lock the door shut.

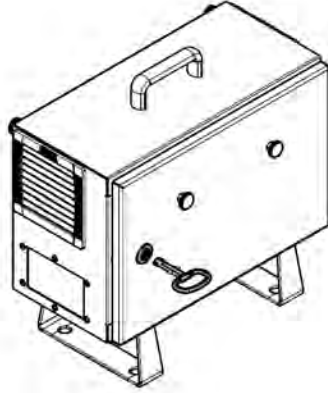

- 6 There is a black Ethernet cable connected to the READY pendant. This cable allows the READY pendant to communicate with the IPC. Route the Ethernet cable to a LAN port on your IPC.

POWERING ON

- 1 Plug your IPC's power cable into a power outlet.
- 2 Plug the UR Control box's power cable into a power source.
- 3 Power on your IPC.
- 4 Press the power button on the UR Teach pendant to turn it on. The power button turns green.



PREPARING POLYSCOPE ON A CB-SERIES ROBOT

- 1 Move the UR robot to a safe position close to the base of the robot. This reduces the chance of the robot faulting during the initialization process.

Note: Remove the end effector to position the robot without causing a protective stop. After setting the default payload and TCP, re-attach the end effector, then initialize the robot arm.

Note: If you don't know how to move the UR robot with the UR pendant, refer to UR documentation.

- 2 Set the default TCP and initialize the robot:

- a Tap **Setup Robot**.

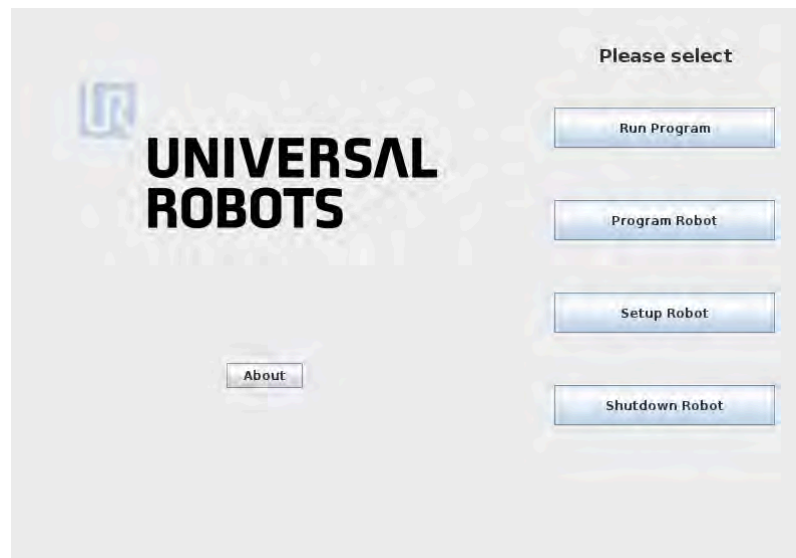

b Tap **Initialize Robot**.



c Tap **Configure TCP**.



d Set your Tool Center Point (TCP), payload, and center of gravity. The settings save when you tap **Exit**.

Note: The TCP is where the end effector interacts with the rest of the workcell.

Note: The payload is the amount of weight attached to the end of the robot. Make sure that you account for the weight of your end effector and the weight of any parts that it will grab.

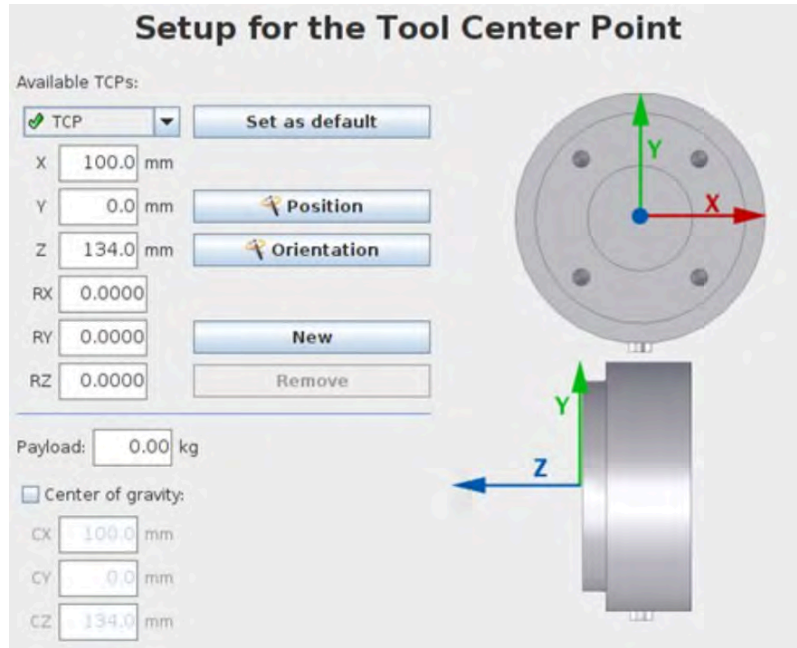

e Tap **ON** to enable the servos. The green dot turns yellow to indicate that the robot is idle.



f Tap **START** to release the brakes. The robot will make some clicking sounds and small movements.

Note: Make sure that the robot arm is not touching an object (e.g., a table). A collision between the robot arm and an obstacle might damage a joint gearbox.



g Press **OK** in the bottom-right corner to apply the initialization.

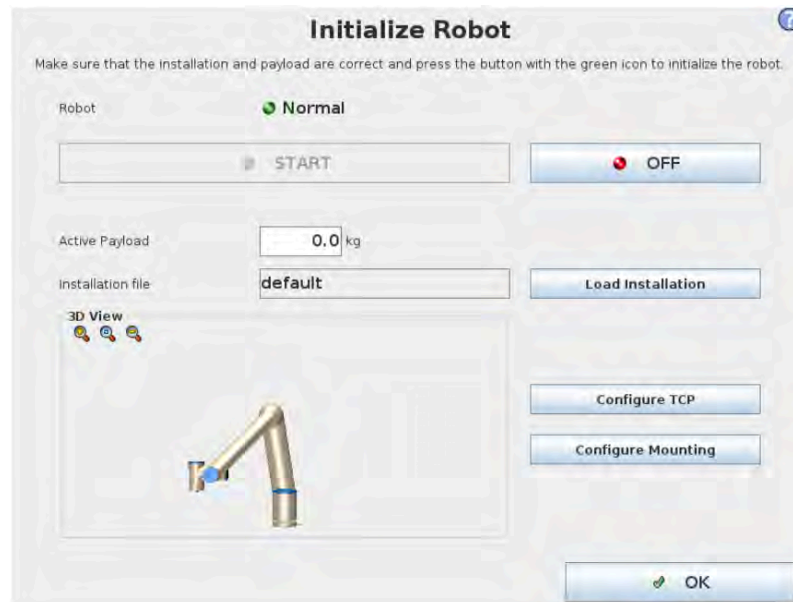

3 Change the network settings to connect with Forge/OS:

a Tap **Network**.



b Tap **Static Address**.



c Set the **IP Address** to **192.168.1.20** and set the **Subnet Mask** to **255.255.255.0**.

d Tap **Apply**.

SIGNING IN TO FORGE/OS

Follow these steps to pair the READY pendant with the IPC and sign in to Forge/OS 5.

- 1 If you need to install Forge/OS 5 on your IPC, stop here and follow all the steps in [Appendix A](#), then come back to these steps.

- 2 The READY pendant automatically finds and pairs with the IPC. The three LEDs on the screen help you track the status:

- **Pendant Network Connection:** This condition is satisfied when the READY pendant has a valid network connection (i.e., the Ethernet cable is plugged in).
- **Forge/OS IPC Detected:** This condition is satisfied when the READY pendant detects a Forge/OS IPC on the network.
- **Forge/OS IPC Paired:** This condition is satisfied when the READY pendant successfully pairs with the IPC. If pairing fails, it is automatically retried indefinitely.

When a condition is not satisfied, the LED is red. When a condition is in progress of becoming satisfied, a spinner around a READY logo appears to the right of the text. When a condition becomes satisfied, the LED turns green.

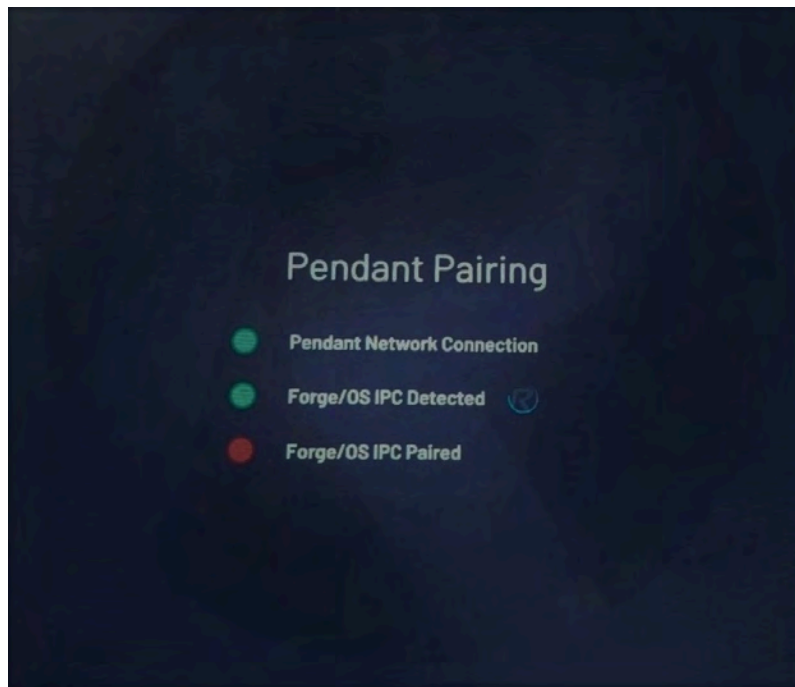

The UI shows the real-time state of each step. For example, if the pendant loses its network connection during pairing, all steps become undone.

If the READY pendant spends more than 60 seconds on any step, troubleshooting text displays. Common things

to check are if the READY pendant network cable is plugged in, if the IPC is powered on, if the READY pendant and IPC are connected to the same network, and if there's only one READY pendant and one IPC on that network.

Note: The **READY pendant** IP Address is preset to 172.16.255.253. The network interface that the pendant connects to should use IP Address 172.16.255.250 and Subnet mask 255.255.255.0.

3

Tap **Admin** and sign in. The default Admin password is "forgeadmin".

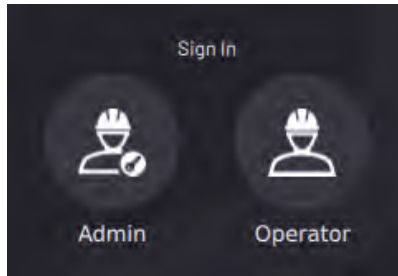

4

If Forge/OS is inactive, it opens the Settings app and prevents you from opening other apps. If you see the screen below, follow [Activating Forge/OS with a License Code](#) in Appendix A.

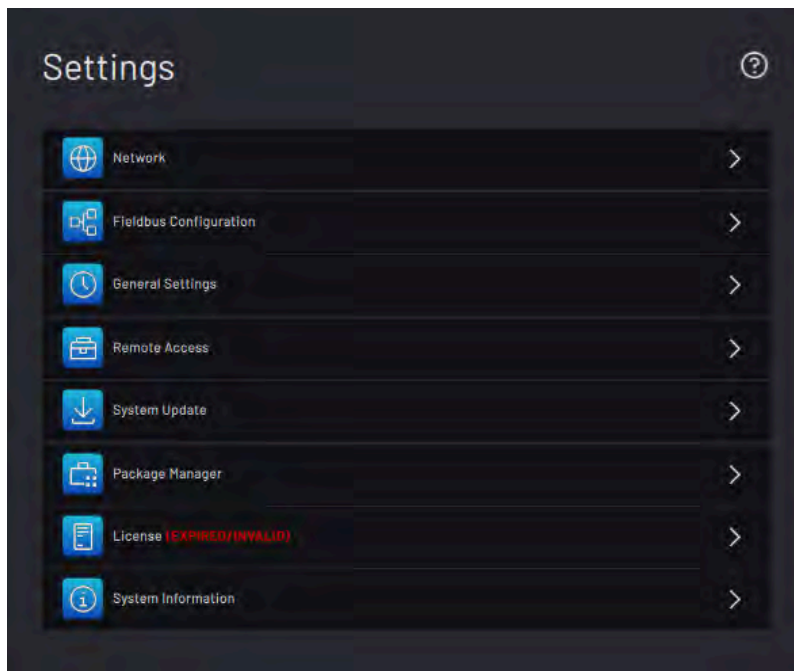

5

With Forge/OS active, move on to the next section.

TRANSFERRING CONFIGURATION FILES

In Forge/OS 5.3.0 and later, CB-Series UR robots require you to load a file on the UR controller.

Follow these steps to create a new UR robot device.

Note: If you are upgrading from a previous version of Forge/OS, **edit** your existing robot device in the Device Configuration app. Follow these instructions starting from the "Copy Configuration Files" step.

- 1 In the **Admin** role, open the **Device Configuration** app.



- 2 Tap **New +** to open the Device Library.

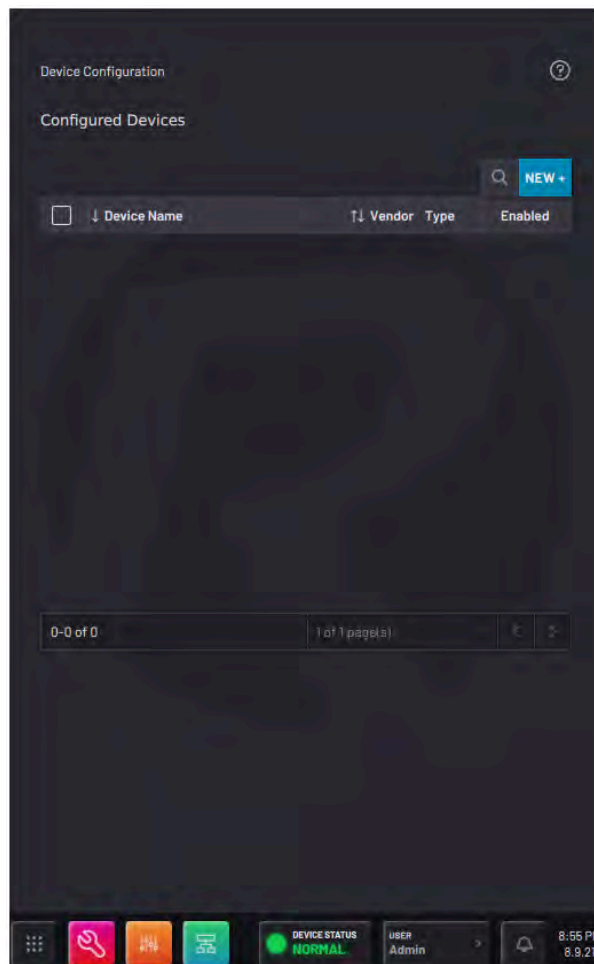

3 In the Device Library list, select **Universal Robots Robot**. Then tap **NEXT**.

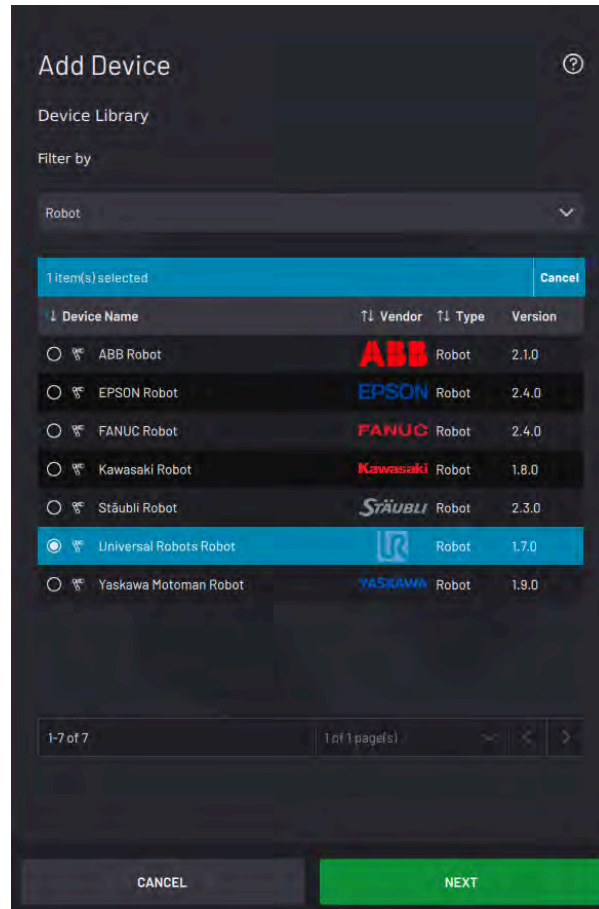

- 4 Select the robot **Controller Model**, then select the **Robot Model**. You can fill in the other information later.

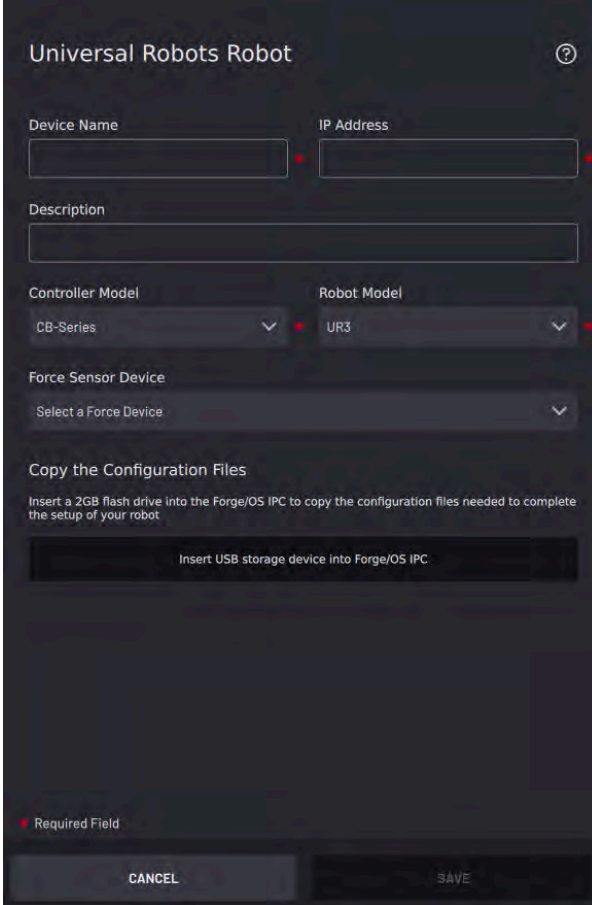

Universal Robots Robot

Device Name IP Address

Description

Controller Model Robot Model

CB-Series UR3

Force Sensor Device

Select a Force Device

Copy the Configuration Files

Insert a 2GB flash drive into the Forge/OS IPC to copy the configuration files needed to complete the setup of your robot.

Insert USB storage device into Forge/OS IPC

Required Field

CANCEL SAVE

- 5 If you are using Forge/OS 5.3.0 or later, insert a USB flash drive into the IPC as instructed on the screen. Use an empty flash drive with at least 2GB of storage.

Tip: Do not connect the USB flash drive to the READY pendant.

- 6 Tap **Start Transfer** and wait for it to finish.
- 7 Remove the USB flash drive when prompted.
- 8 Insert the USB drive into the USB port of the UR pendant.

- 9 On the UR pendant home screen, tap **Program Robot**.

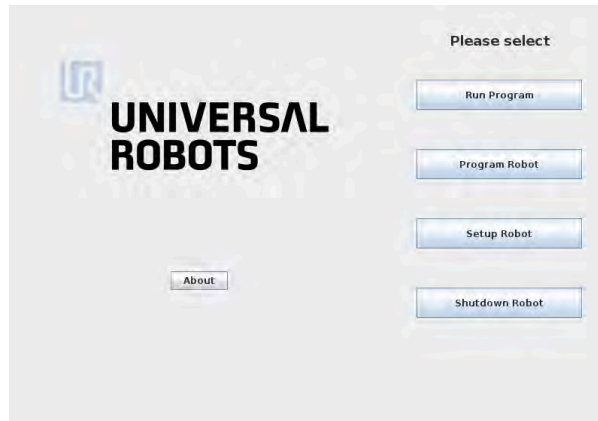

- 10 In the **File** menu in the upper-right corner, tap **Load Program**.

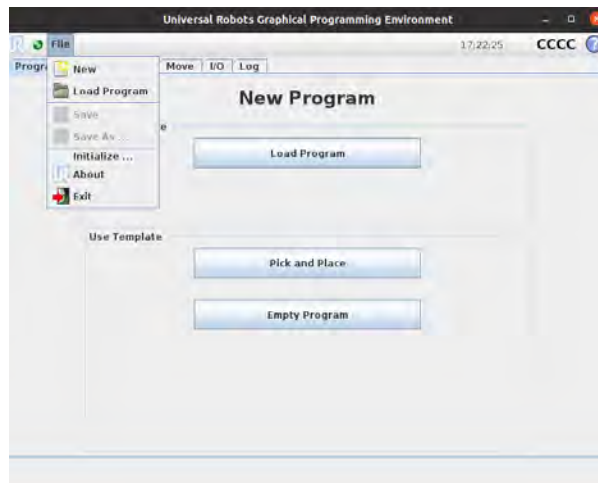

- 11 In the Current Directory of `"/programs"`, tap **usbdisk**.

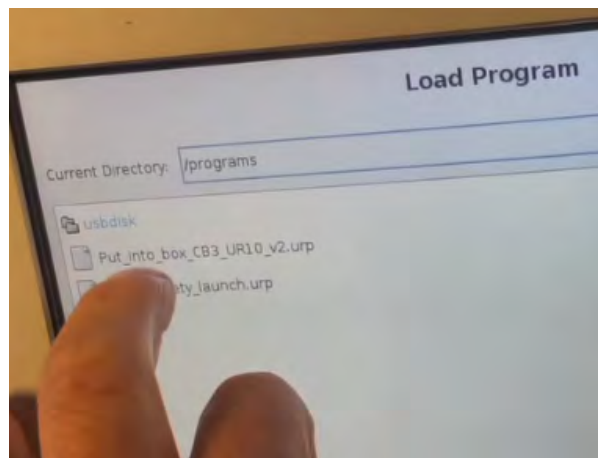

12 Tap **forge-os**.

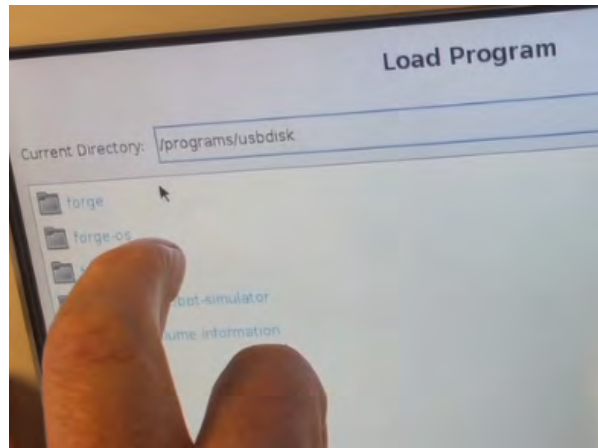

13 Tap **ready-universal-robots-driver**.

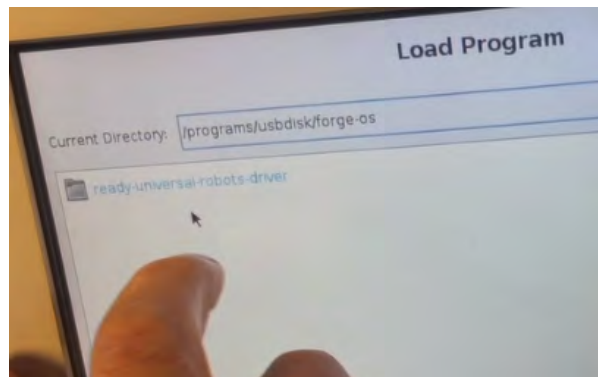

14 Select **ForgeOS.urp**. Then tap **Open**.

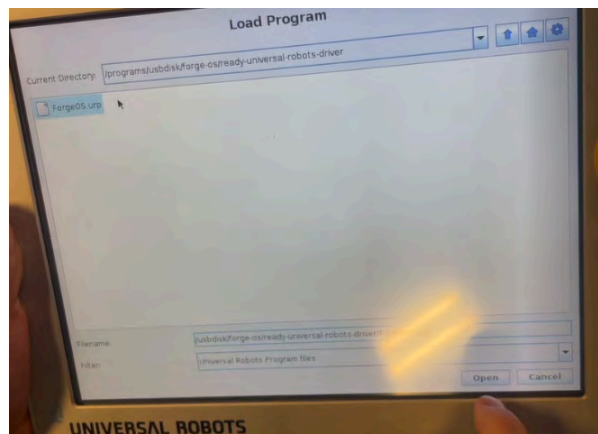

- 15 If you see a pop-up that reads, "Installation file could not be found. Would you like to use the currently loaded installation?"; tap **YES**.

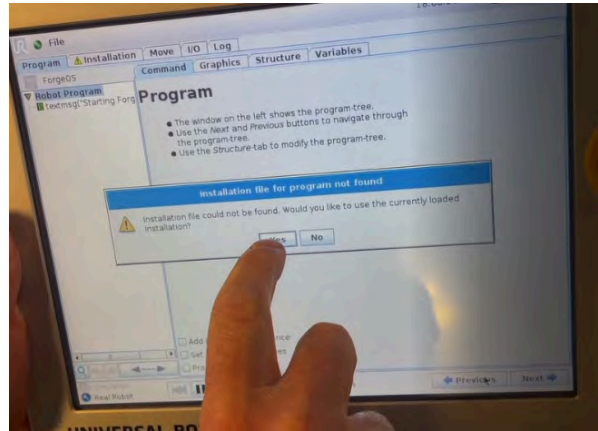

- 16 In the **File** menu, tap **Save As...**

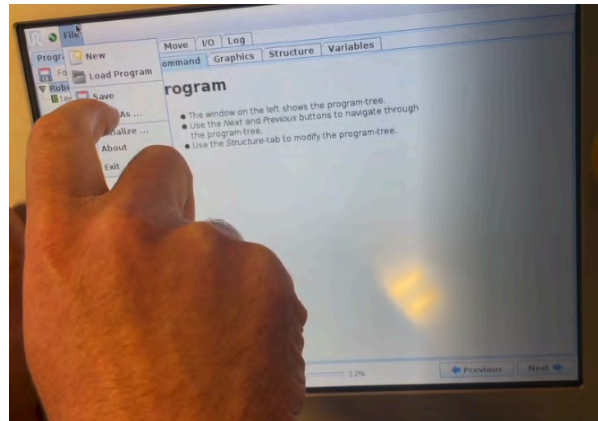

- 17 In the upper-right corner, tap the **Home** button (the middle icon). This returns the Current Directory to "/>

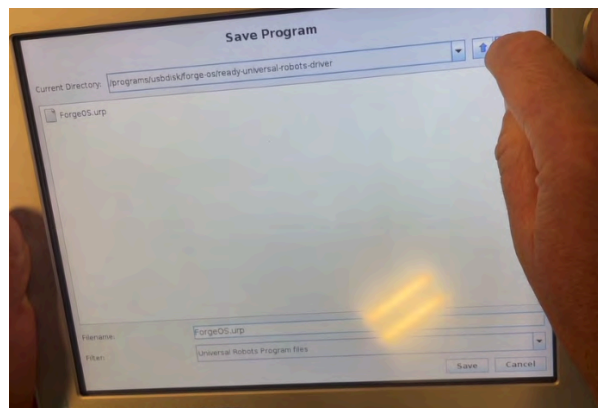

18 Tap **Save**.

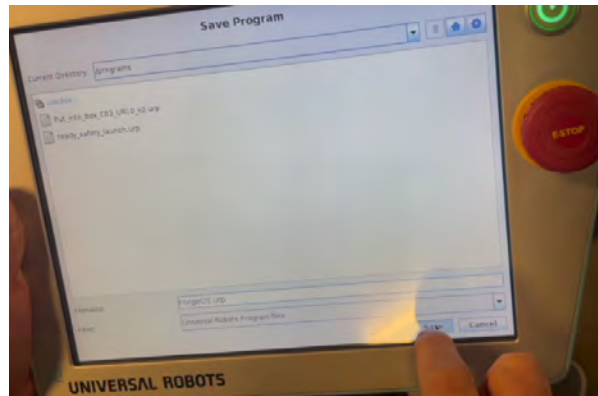

19 The pendant returns to the screen shown below.

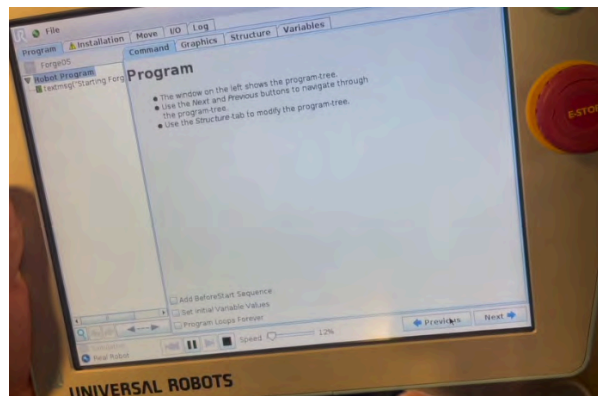

ADDING THE UR ROBOT IN DEVICE CONFIGURATION

1 In Forge/OS, finish entering your device information:

- a Give your device a **name**.
- b Type in the device **IP Address** that you entered in the PolyScope network settings.
- c If you are using a **Force Sensor Device**, select it from the dropdown. The dropdown lists configured force sensor devices.

2 In Forge/OS, confirm your device settings and tap **SAVE**. Forge/OS attempts to connect with the robot controller for up to 20 seconds.

Note: When you first connect to a robot, it's normal to see some robot errors and/or warnings on the **READY pendant**. Ignore these for now. You will clear them after you finish adding the robot to Forge/OS.

a If the robot controller fails to connect, you see this pop-up.

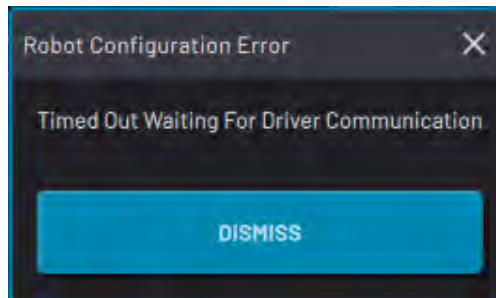

Click **DISMISS**, do the following, then try to tap **SAVE** again:

- Check the Ethernet connection between the robot controller and IPC.
- Check the network settings on the robot controller.
- Check if the robot controller is on and in the correct operating mode (in auto or remote mode).
- Select the correct robot controller and robot models in Device Configuration.

- 3 Leave the **Tool Center Points (TCPs)** and **Payloads** as the Default values. Instead of adding new TCPs and payloads here, set them up in Polyscope. Tap **NEXT**.

Note: For more information on setting up TCPs and payloads in Polyscope, refer back to the "Preparing Polyscope" section.

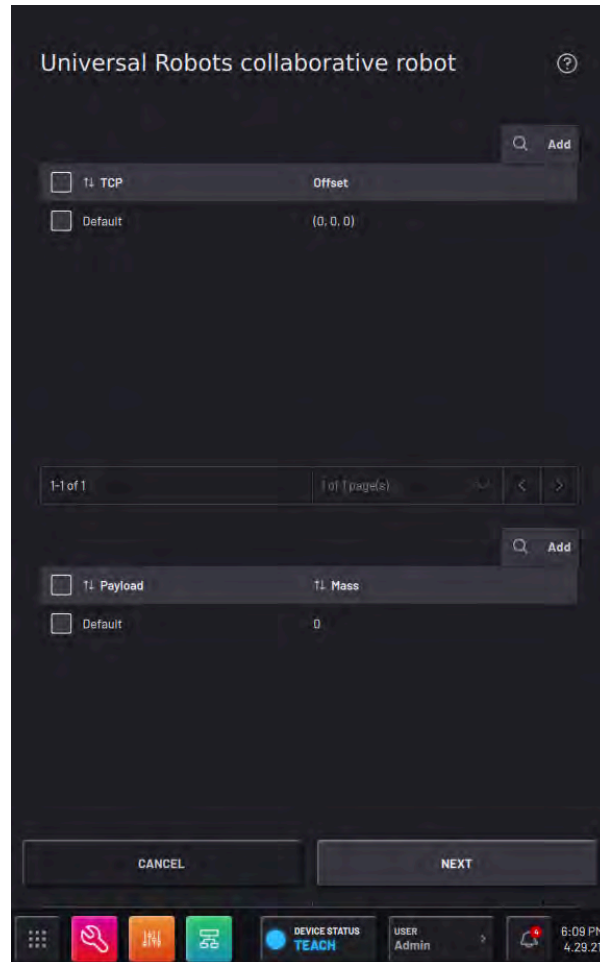

4 (Optional): Set up the robot controller's Input/Output (IO) signals for use in the Device Control Panel and Task Canvas.

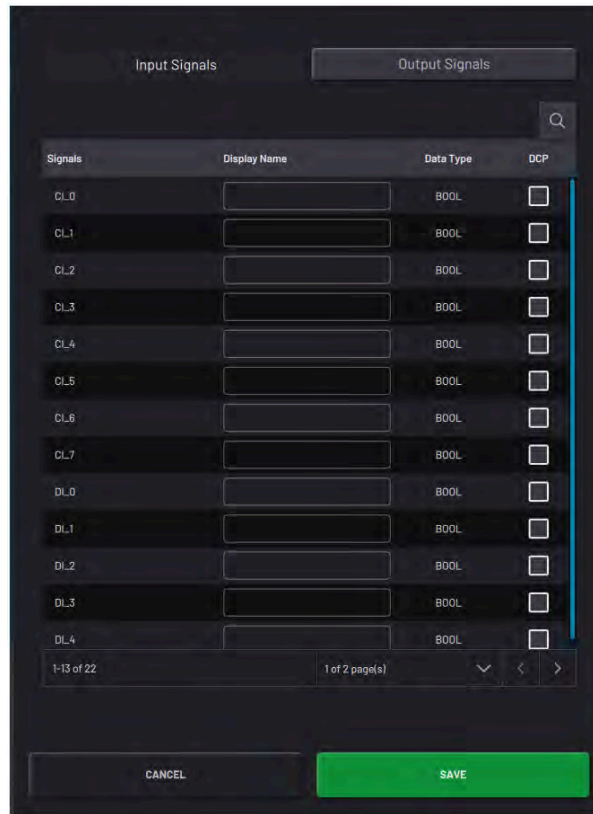

a Enter a **Display Name** (i.e. "Open Machine Door", "Open Pneumatic Vise", or "Start Machining Cycle") to show what each signal does in other apps.

b If you want a signal to appear in the Device Control Panel, check the **DCP** box next to that signal.

Note: To use these I/O signals, integrate your I/O devices with the robot controller.

c Tap **SAVE**. Forge/OS returns to the Configured Devices list, which shows the new robot as **enabled**.

Note: A device is **enabled** when its switch is green and toggled to the right.

5 Follow these steps to clear robot errors:

a Tap the **Device Status** button on the Toolbar to expand the Device Status Panel. The robot is listed with two buttons: **MORE** and **RESET**.

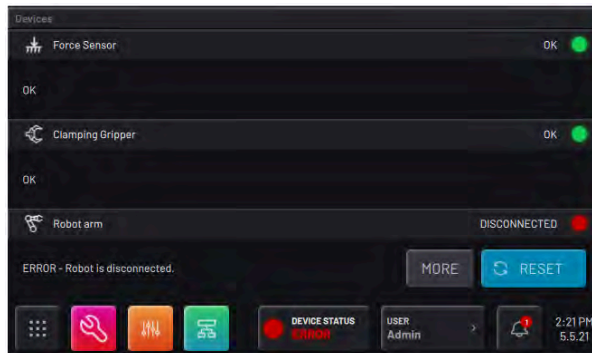

b Tap **RESET** to try to recover from the errors. If you can't **RESET** an error, tap **MORE** to get more details and instructions.

Congratulations! You are ready to control your robot in the Device Control Panel and Task Canvas apps.

APPENDIX A: SETTING UP FORGE/OS

INSTALLING FORGE/OS

Follow these steps to install Forge/OS and sign in to the Admin role. Installation takes about 30 minutes, depending on the resources of the IPC.

- 1 To install Forge/OS, follow these substeps. You need a Forge/OS installation USB flash drive. Contact your READY Robotics distributor for an installation USB drive.

Important: Installing Forge/OS will erase all data on the target hard drive.

- a Connect a monitor, keyboard, and mouse to the IPC where you want to install Forge/OS.



- b Plug the Forge/OS installation USB flash drive into the IPC.

Tip: If you need more USB ports, use a USB 3.0 hub.

- c Restart the IPC. While the IPC is powering on, press the keyboard hotkey that takes you to the Boot Menu.

Tip: The key that opens the Boot Menu depends on the **IPC** model. The most common keys that do this are ESC, F10, F11, or F12. Refer to your computer's documentation for boot options.

- d From the boot options, select **Install Forge/OS** to boot from the installation USB flash drive.

- e The installer may take several minutes to load. Wait until the installation wizard opens.

f Select your language. Then click **Install Forge**.

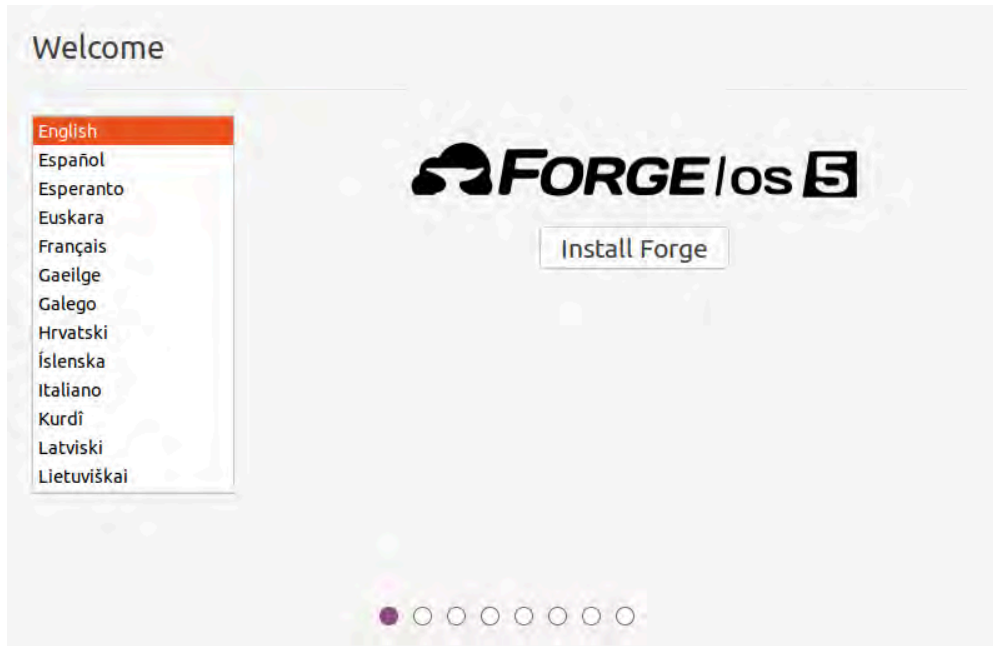

g Choose a keyboard layout. Then click **Continue**.

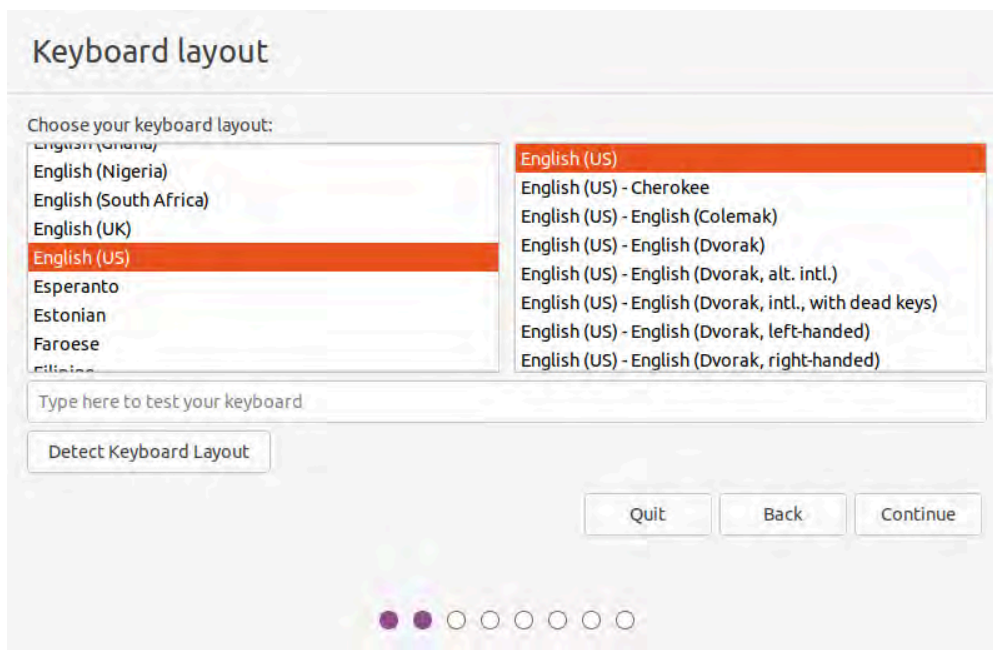

h

Select **Minimal installation**. Uncheck **Download updates while installing forgeos**. Then click **Continue**.

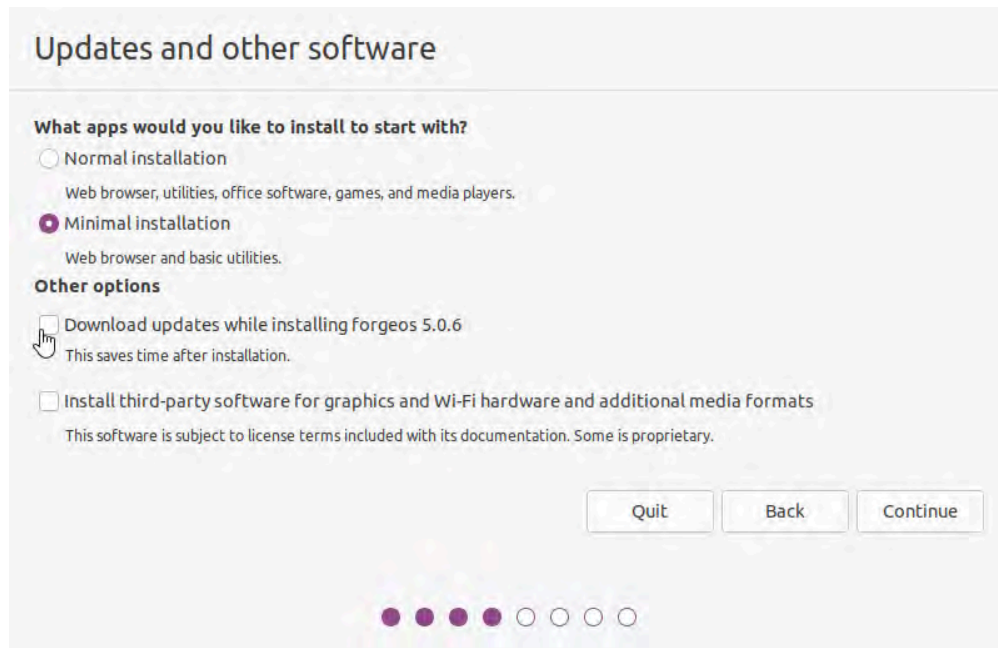

i

Select **Erase disk and install forgeos**. Then click **Continue**.

Note: If Forge/OS is already installed, the installation wizard will show additional options. The goal is to erase the entire disk for a brand new installation.

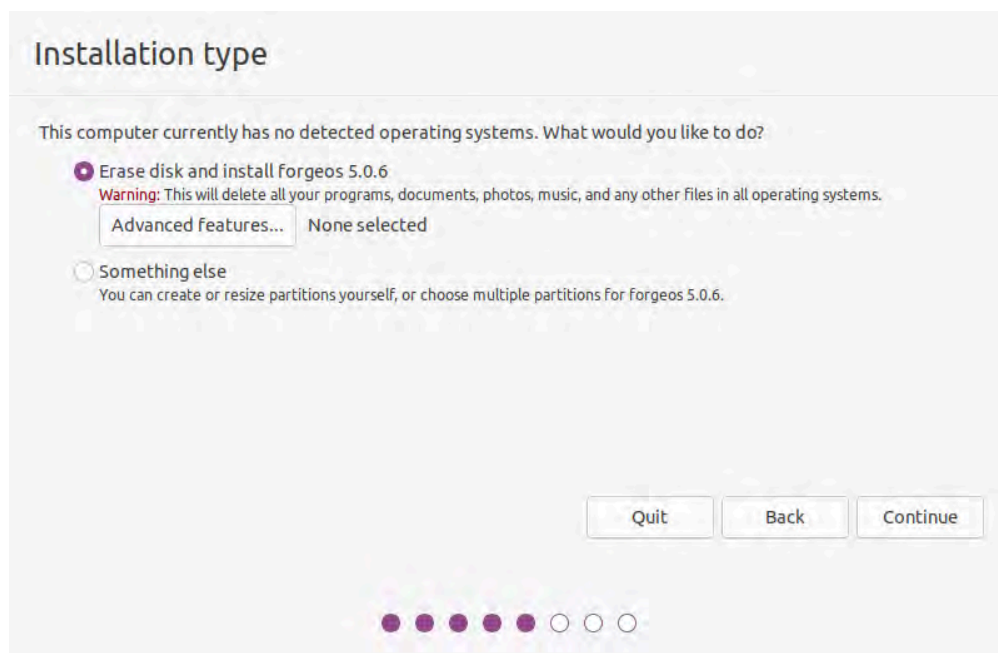

j Select the IPC hard drive for Forge/OS and click **Install Now**.

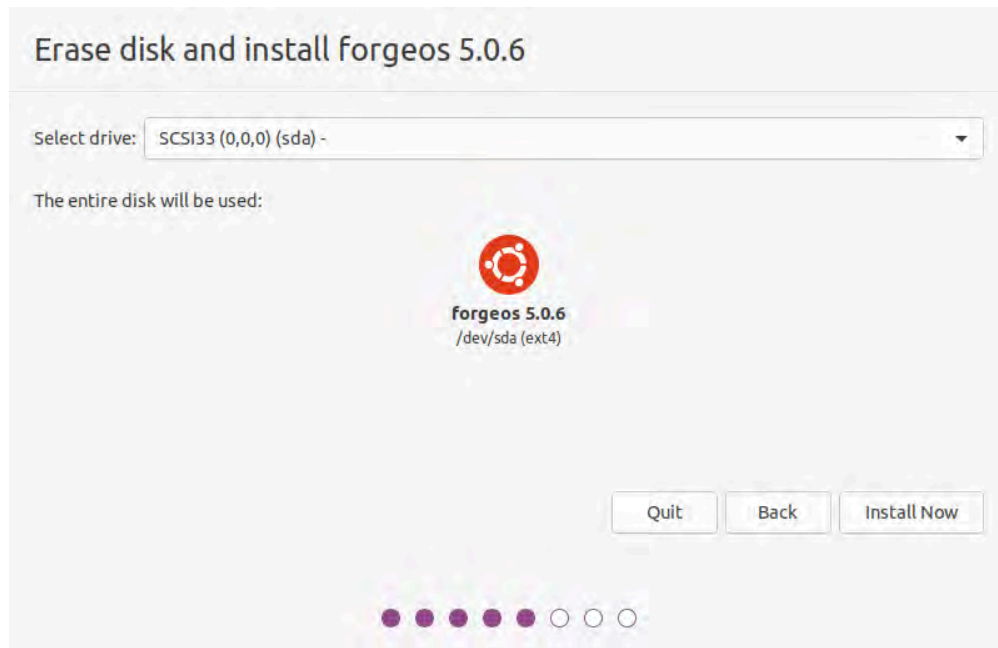

k Confirm that you want to erase the entire disk by clicking **Continue**.

l Make a note of the pendant instructions. If you're using a Forge/Ctrl, select the checkbox next to **This hardware is a Forge CTRL**.

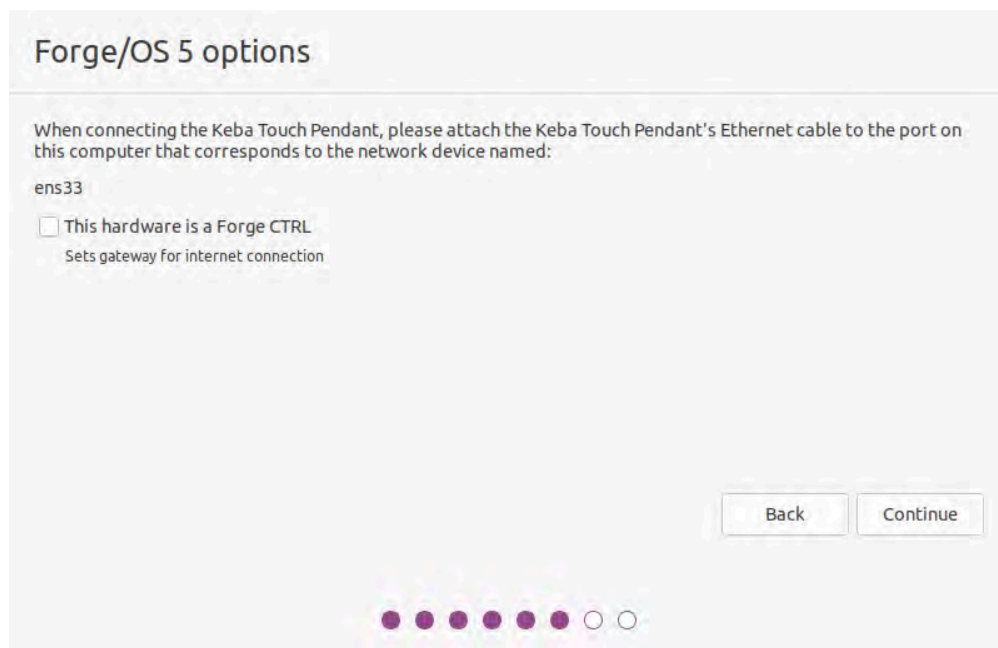

m Choose your timezone. Then click **Continue**.

n Choose your IPC's host name. The host name identifies the IPC on the network. Pick a username and password. Then click **Continue**.

Note: The username and password that you create here are for accessing the IPC desktop. They are NOT for signing into Forge/OS on the **READY pendant**.

- o Wait for the installer to copy and install Forge/OS.

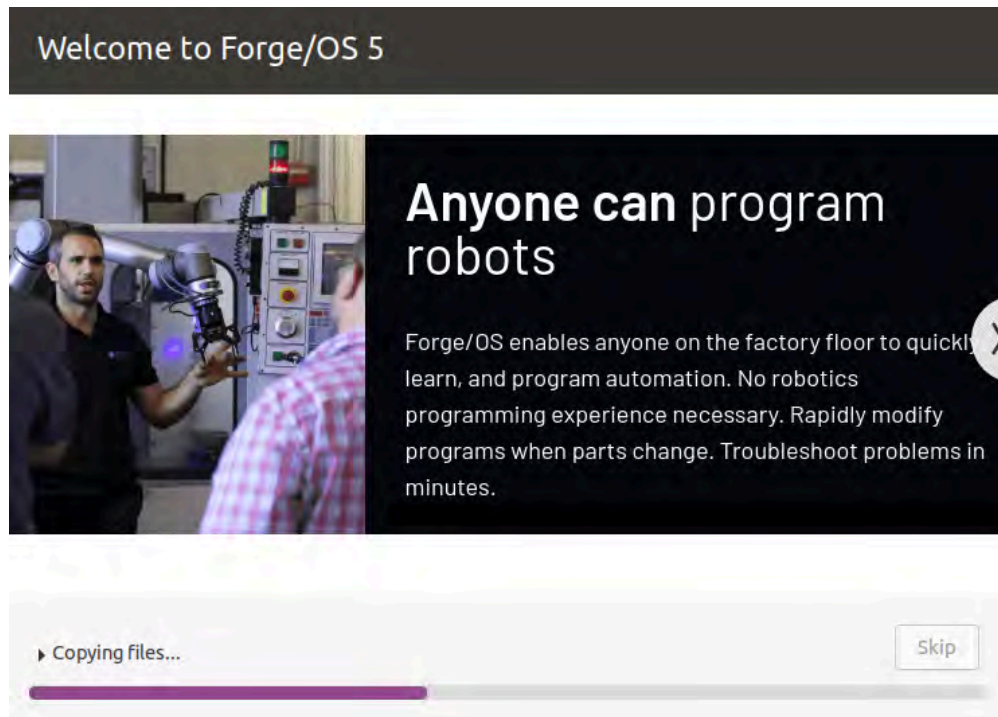

- p Once the installation completes, click **Restart Now**.

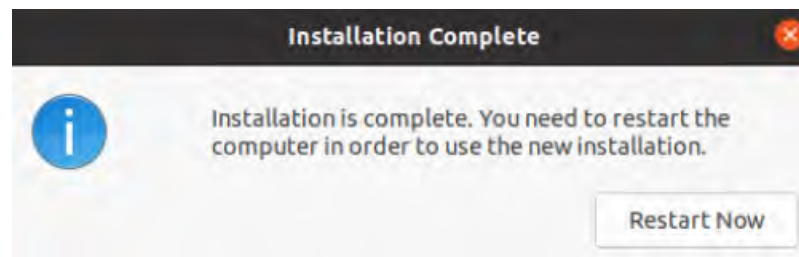

- q When prompted, remove the installation flash drive. Then reboot.

```
Please remove the installation medium, then reboot.  
_
```

- r Wait for Forge/OS to finish booting.

S

When you see the login screen with the Forge/OS 5 logo, Forge/OS is ready to run on the READY pendant! You don't need to sign in to the desktop. Disconnect the monitor, keyboard, and mouse that you used to install Forge/OS.

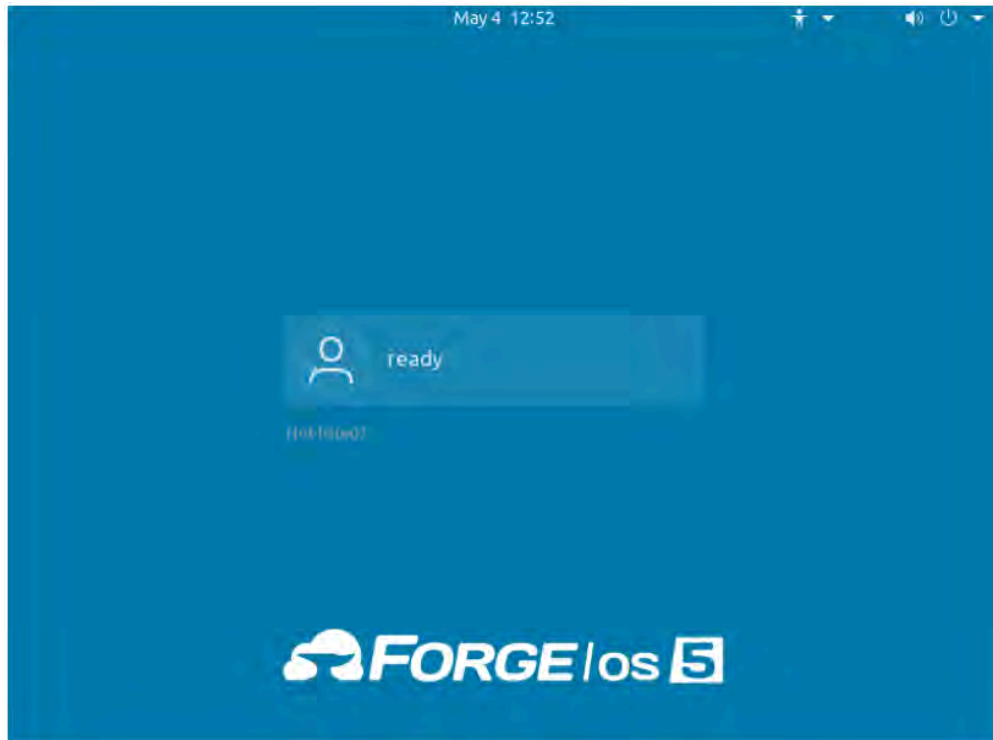

2 The READY pendant automatically finds and pairs with the IPC. The three LEDs on the screen help you track the status:

- **Pendant Network Connection:** This condition is satisfied when the READY pendant has a valid network connection (i.e., the Ethernet cable is plugged in).
- **Forge/OS IPC Detected:** This condition is satisfied when the READY pendant detects a Forge/OS IPC on the network.
- **Forge/OS IPC Paired:** This condition is satisfied when the READY pendant successfully pairs with the IPC. If pairing fails, it is automatically retried indefinitely.

When a condition is not satisfied, the LED is red. When a condition is in progress of becoming satisfied, a spinner around a READY logo appears to the right of the text. When a condition becomes satisfied, the LED turns green.

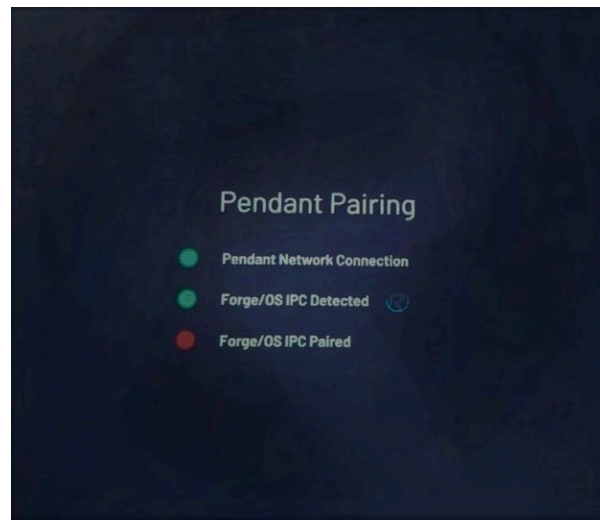

The UI shows the real-time state of each step. For example, if the pendant loses its network connection during pairing, all steps become undone.

If the READY pendant spends more than 60 seconds on any step, troubleshooting text displays. Common things to check are if the READY pendant network cable is plugged in, if the IPC is powered on, if the READY pendant and IPC are connected to the same network, and if there's only one READY pendant and one IPC on that network.

Note: The **READY pendant** IP Address is preset to 172.16.255.253. The network interface that the pendant connects to should use IP Address 172.16.255.250 and Subnet mask 255.255.255.0.

- 3 Tap **Admin** and sign in. The default Admin password is "forgeadmin".

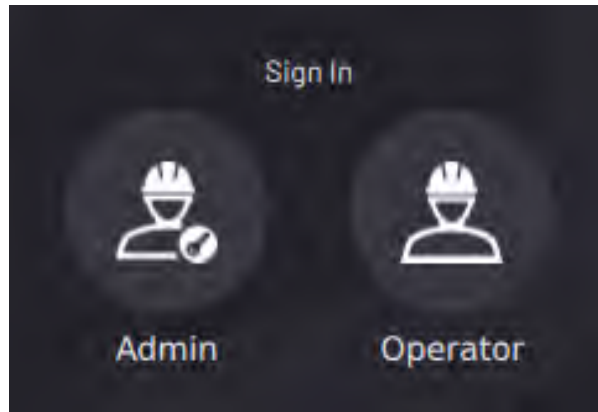

Note: After installation, you have limited access to Forge/OS until you activate it with a license code. See [Activating Forge/OS with a License Code](#).

ACTIVATING FORGE/OS WITH A LICENSE CODE

There are two methods to activate Forge/OS: **Online license activation** and **offline license activation**.

The table below lists the requirements for each method.

Online License Activation	Offline License Activation
<ul style="list-style-type: none"> An internet-connected Forge/OS A valid Forge/OS license code 	<ul style="list-style-type: none"> A 2GB or larger USB flash drive An internet-connected PC A valid Forge/OS license code

Tip: Connect a USB keyboard to the port on the bottom of the **READY pendant** to type in any text field in Forge/OS.

1 On the Settings app main screen, tap **License**.

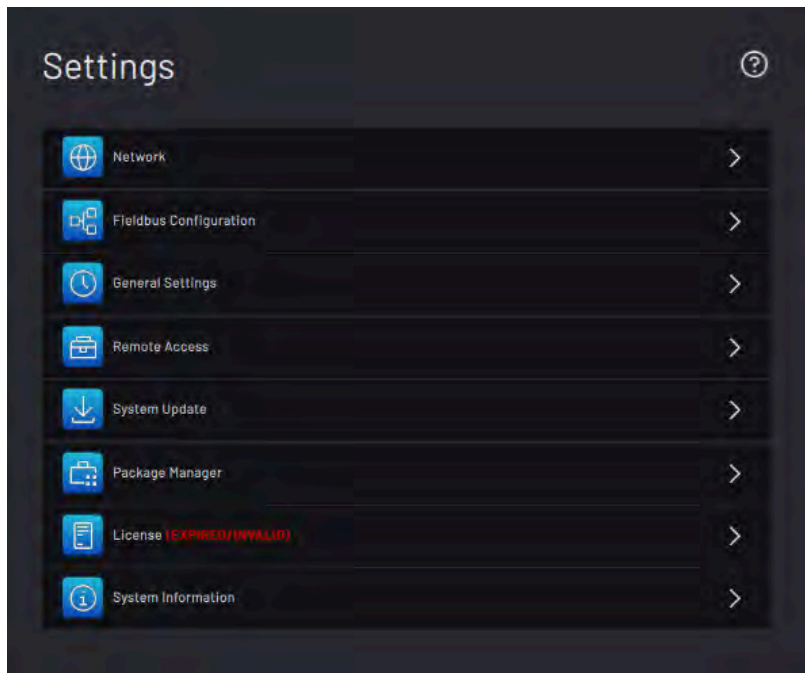

2 Type in your license code.

- 3 Choose **ONLINE LICENSE ACTIVATION** if Forge/OS is connected to the internet. If not, choose **OFFLINE LICENSE ACTIVATION**.

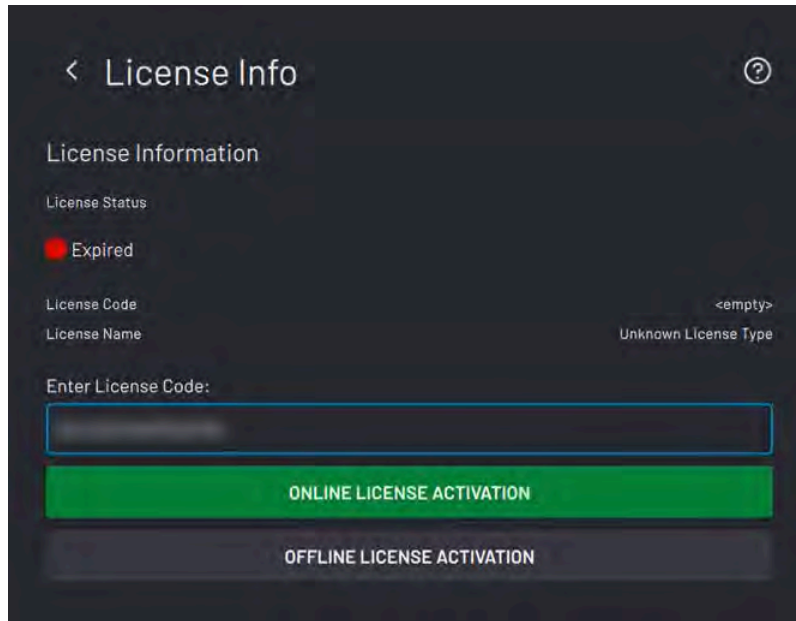

- 4 If you chose online license activation, you're done!

- 5 If you chose offline license activation, follow these substeps:

- a Insert the USB flash drive into your IPC. Tap **START WRITING CERTIFICATE TO USB DRIVE**.

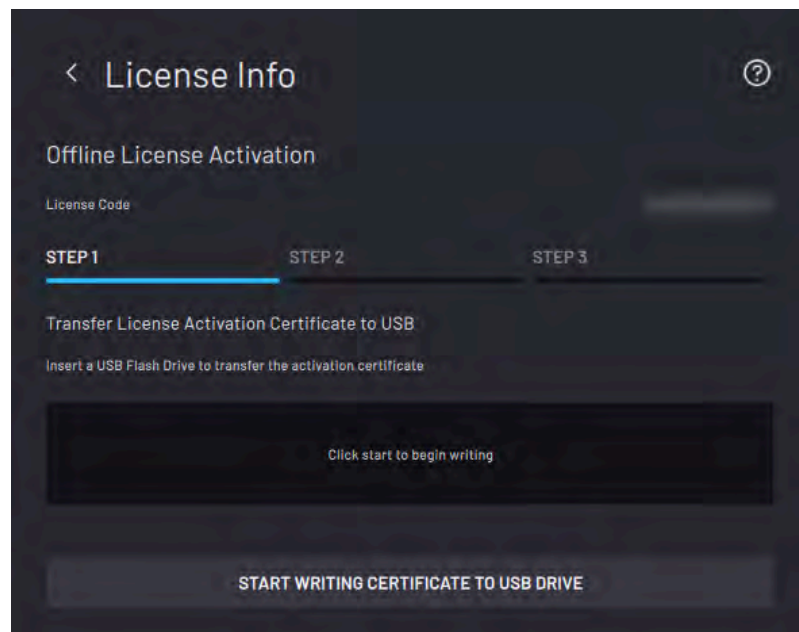

- b** When the files finish transferring, tap **NEXT**. Follow the instructions on the screen to convert the Activation Certificate to an Unlock Certificate using an internet-connected PC.

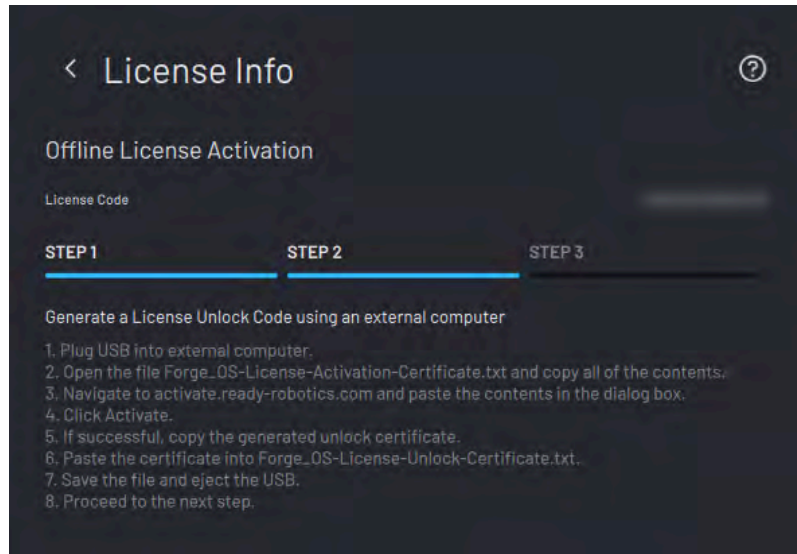

- c** Insert the USB flash drive back into your IPC. Tap **UNLOAD UNLOCK CERTIFICATE FROM USB DRIVE**.

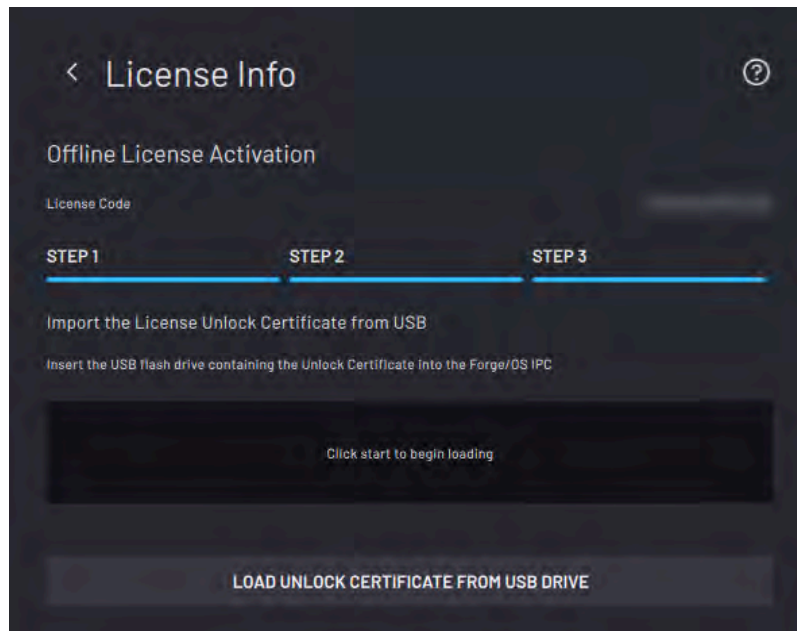

- d** Wait for the file to finish transferring. When the file transfer is complete, remove the USB flash drive and tap **SAVE**.
- e** Forge/OS returns to the licensing home screen and shows an active license. If the license status isn't active, restart these license activation steps. Double-check your license code.

CHOOSING PREFERENCES

These steps help you choose system preferences, including language, units, time, and network settings.

1 To change preferences for the first time, go to General Settings:

a On the Settings app main screen, tap **General Settings**.

b Change the Units of Measure, Time and Date settings, or the Admin login password.

Note: If you later forget your password, contact READY Robotics to reset it.

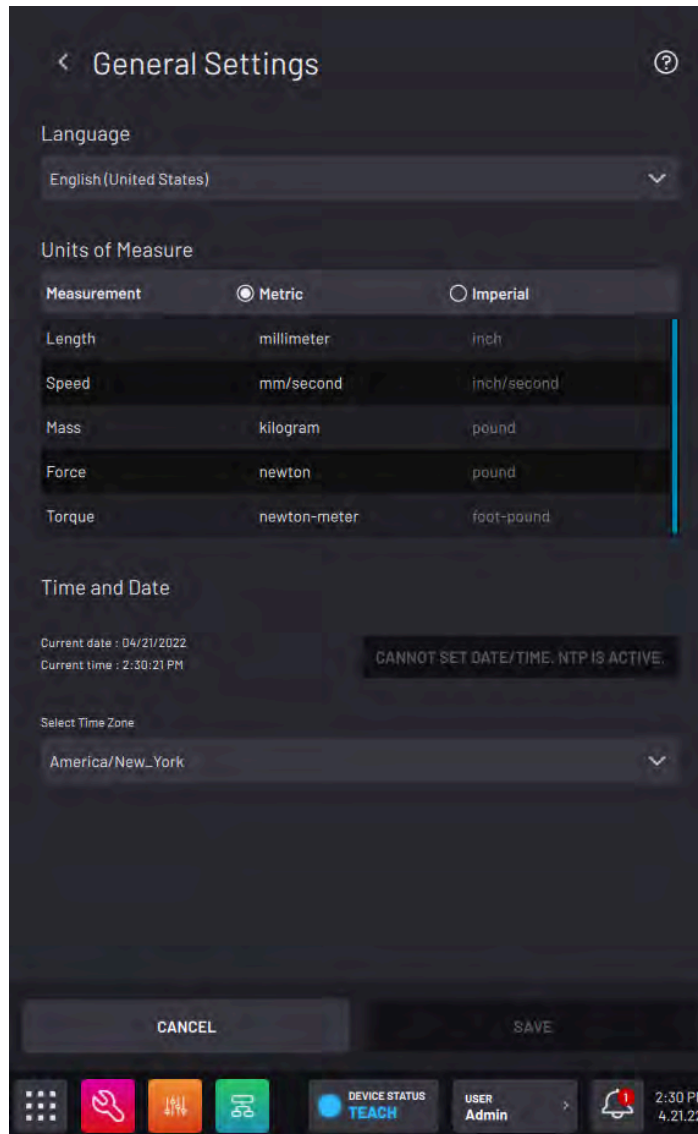

c Tap **SAVE** to save changes and exit the General Settings menu.

2 Check the Network settings in Forge/OS and set them as you want.

a On the Settings main screen, tap **Network**.

b The table below lists the available network interfaces on your IPC. By default, the first interface is for the READY pendant. You can't edit the pendant's interface in Forge/OS. Select another interface and tap **Edit** to see the network settings.

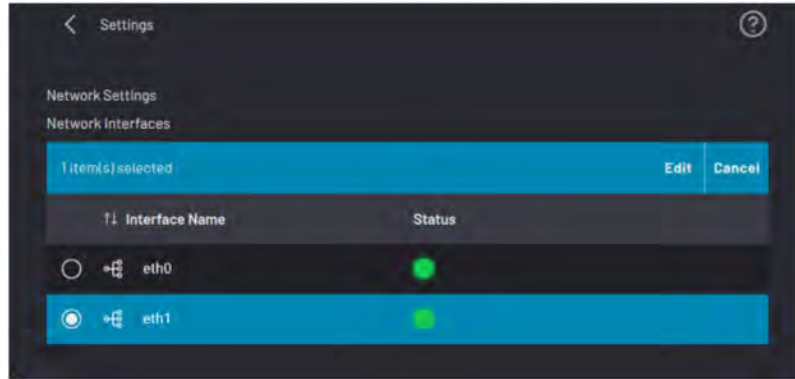

c Change the network interface to match the settings in the image below. Connect robots and other devices to this interface through an Ethernet switch.

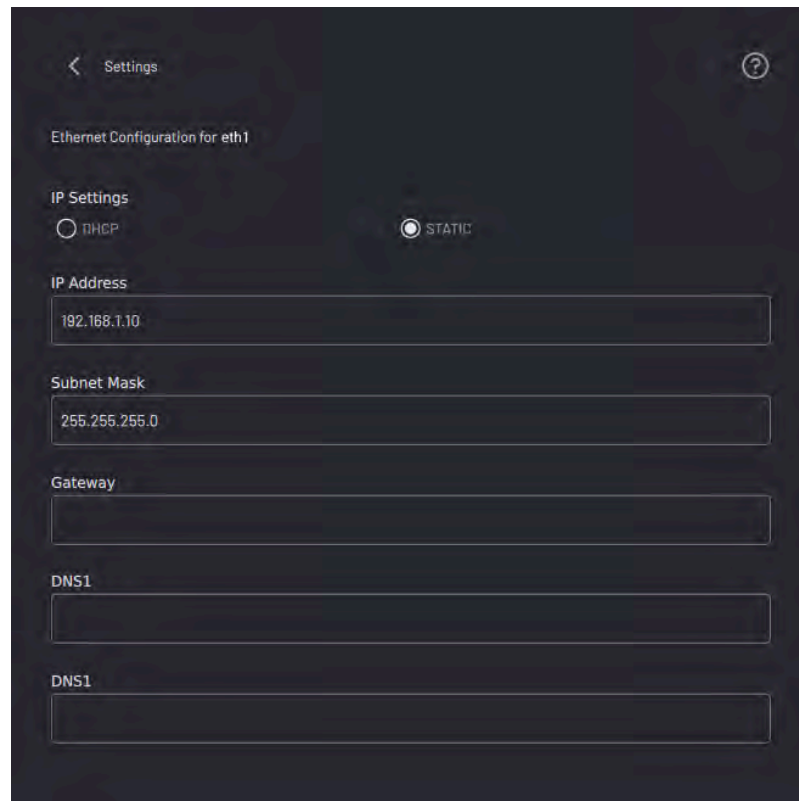

d Tap **SAVE**.

RESOURCES

Want to learn more about how Forge/OS can empower you?

Visit **READY.academy** (ready.academy) for *FREE* hands-on courses to help you deploy a robotic system.

Visit **READY.market** (market.ready-robotics.com) for products and services offered by READY and our partners.

Visit our **Support** site (support.ready-robotics.com) for robot startup guides, FAQs, and more.

Visit our **Resources** page (ready-robotics.com/resources) for articles, whitepapers, and other resources.

If you encounter a problem and need to talk to someone, reach out to us.

- Email READY Robotics: support@ready-robotics.com
- Call READY Robotics: +1-833-732-3977

