



3 Person Clearlight® Premier Far Infrared Sauna | IS-3

FAR INFRARED SAUNA

- True Wave Carbon/Ceramic Far Infrared Heaters
- Grade-A Western Red Canadian Cedar
- Digital Touchpad Control
- Bluetooth/AUX Connectivity*
- Built-in Stereo Speakers
- Built-in Ergonomic Backrest
- Standard Chromotherapy with 15 LED / 6 Colours
- Flat and Ergonomic bench (reversible)



Built-in Charging & Audio Station

Charge your smart device, and connect your audio via Bluetooth or AUX inputs



Reversible Ergonomic bench

Choose between a contoured or flat profile surface



Low EMF

Our True Wave™ heaters are the only infrared heaters with virtually no EMF



No Harmful VOCs

Our saunas are free of any harmful VOCs (Volatile Organic Compounds)



Eco-certified Wood Construction

Eco-certified Grade "A" Clear Western Red Canadian Cedar



Multi Purpose Door Handle

Rest your tablet or smart device on the door handle for ease of use

Features

Innovative Heating technology

Exclusively utilising our patent-pending True Wave™ heaters - an innovative fusion of carbon and ceramic, providing optimal, efficient, and safe therapeutic heat.

Heater upgrade available

The Clearlight® Premier Sauna has the ability to upgrade from Far Infrared to Full Spectrum with the addition of the True Wave™ Full Spectrum Heaters, which provide our highest output heat source, producing near, mid and far infrared wavelengths all at once.

Zero EMF and ELF

Our True Wave™ heaters output virtually zero EMF and ELF, and combined with our EMF shielding technology, we ensure the lowest and safest EMF and ELF exposure on the market.

360° Infrared Heat

Our saunas have heaters on the front wall, back wall, side walls and underneath the bench, heating your body from every direction, which targets your core, rather than just heating the sauna cabin air.

Ergonomically Designed

The chiropractor-designed backrest and reversible bench ensures ultimate comfort for long periods of relaxation. The seat is double-sided, with a contoured profile on one side, and flat on the reverse.

Traditional Sauna Design

The Clearlight® Premier range takes a traditional approach to design, all whilst incorporating cutting-edge technologies to bring this ancient wellness practice into the 21st century, with far-infrared heating and EMF shielding technology.

* For Residential customers only. Warranty on Commercial saunas are 5 years.

** Extra charges for very remote or difficult to access locations

Clearlight®

3 Person Clearlight® Premier Far Infrared Sauna | IS-3

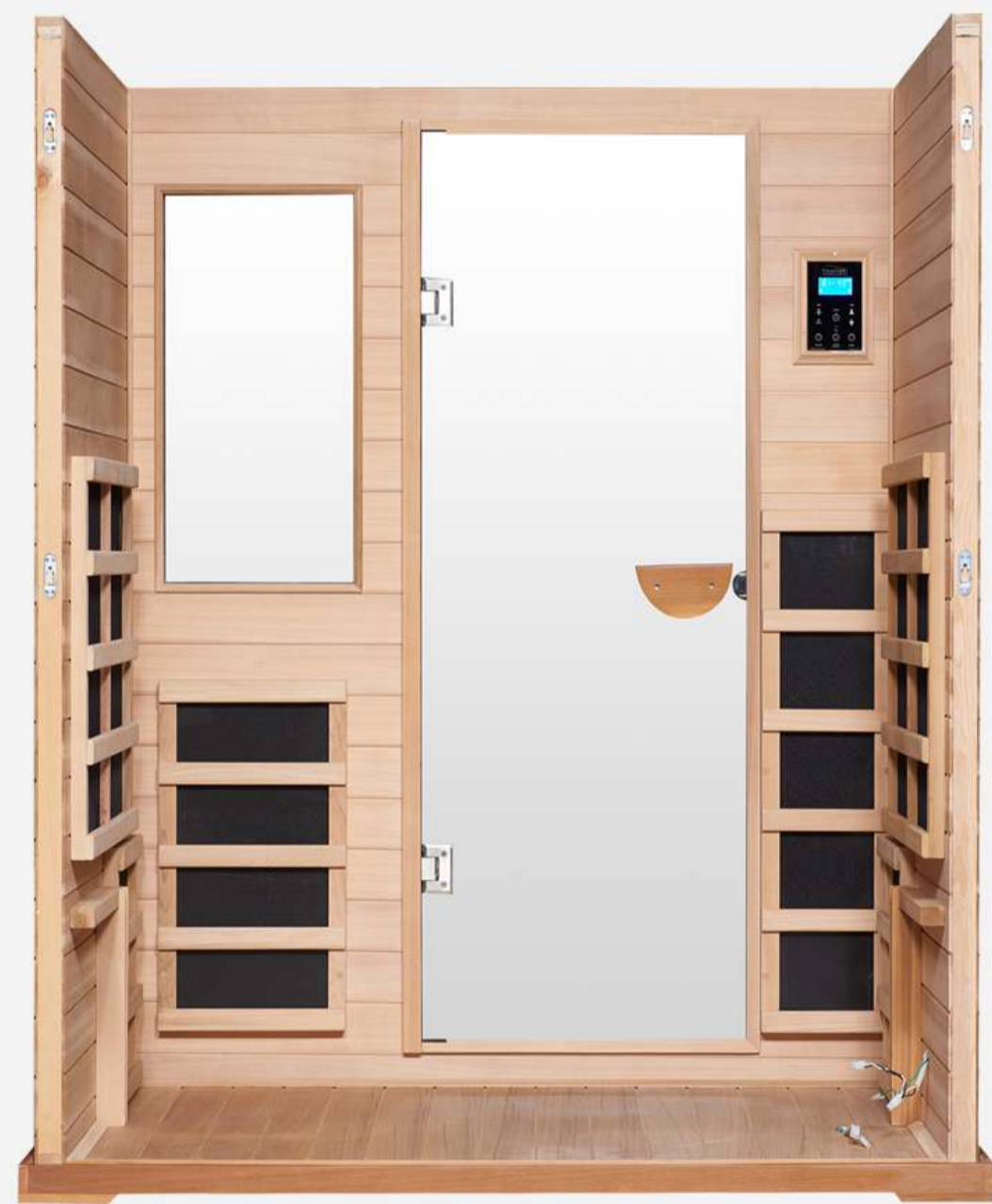

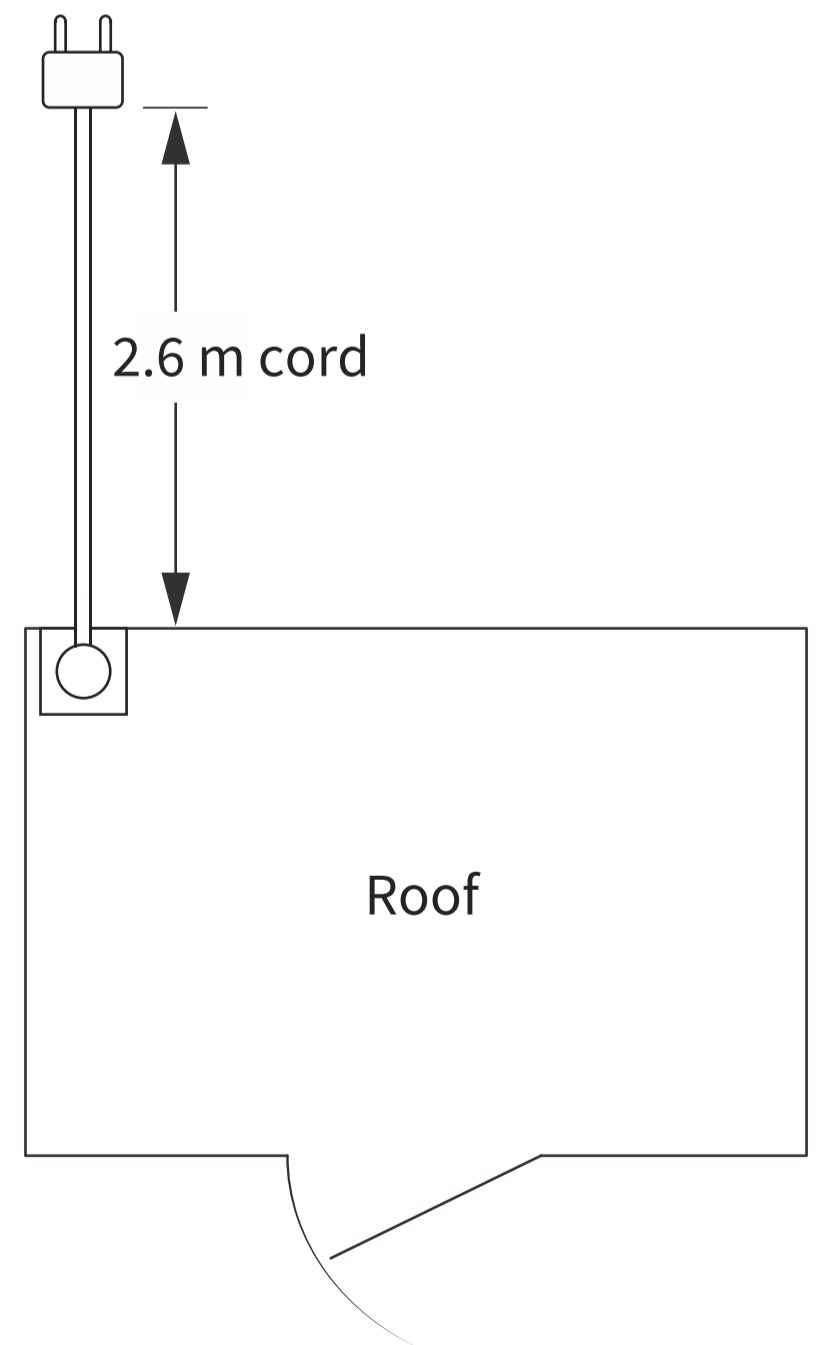
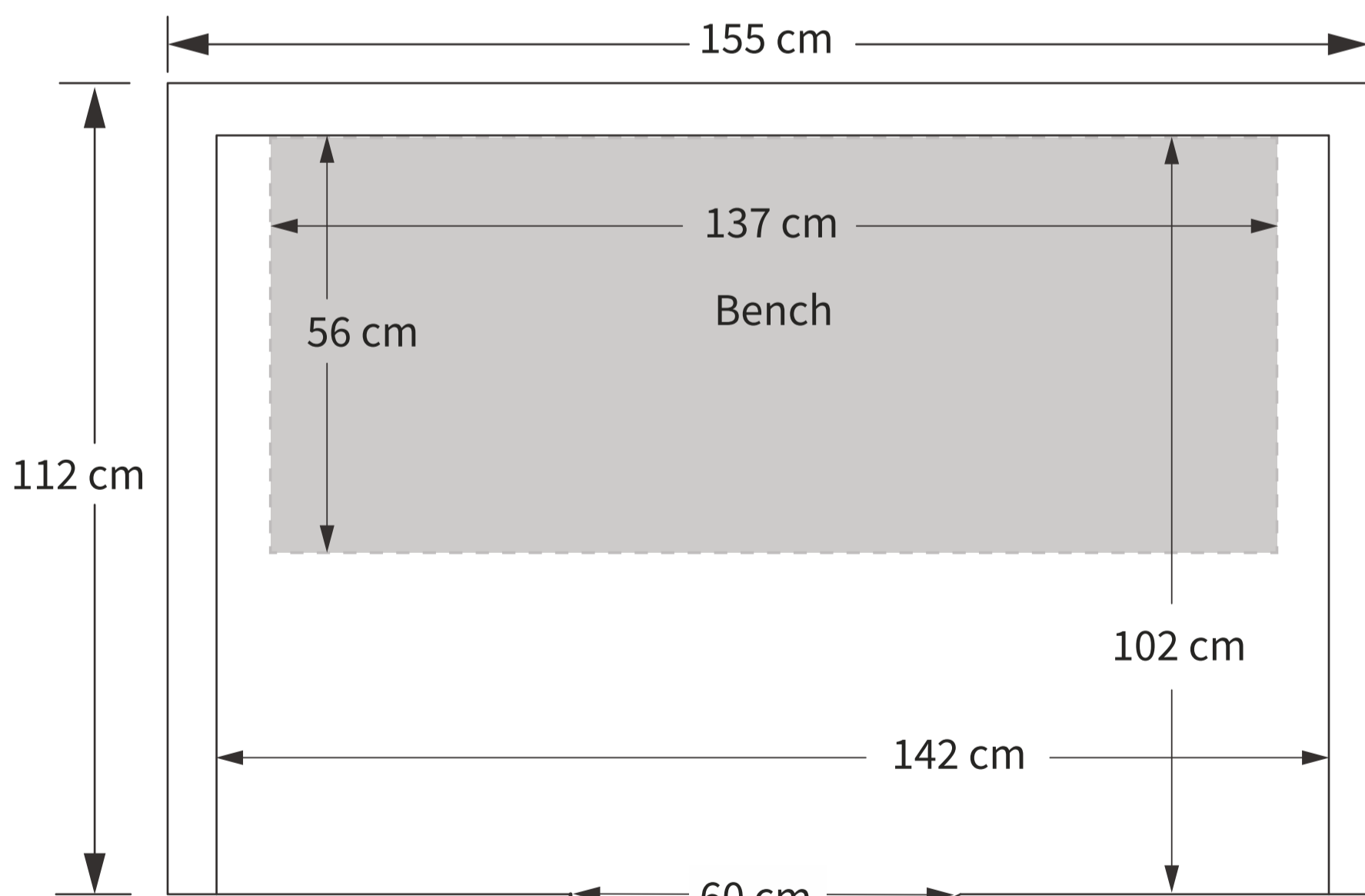
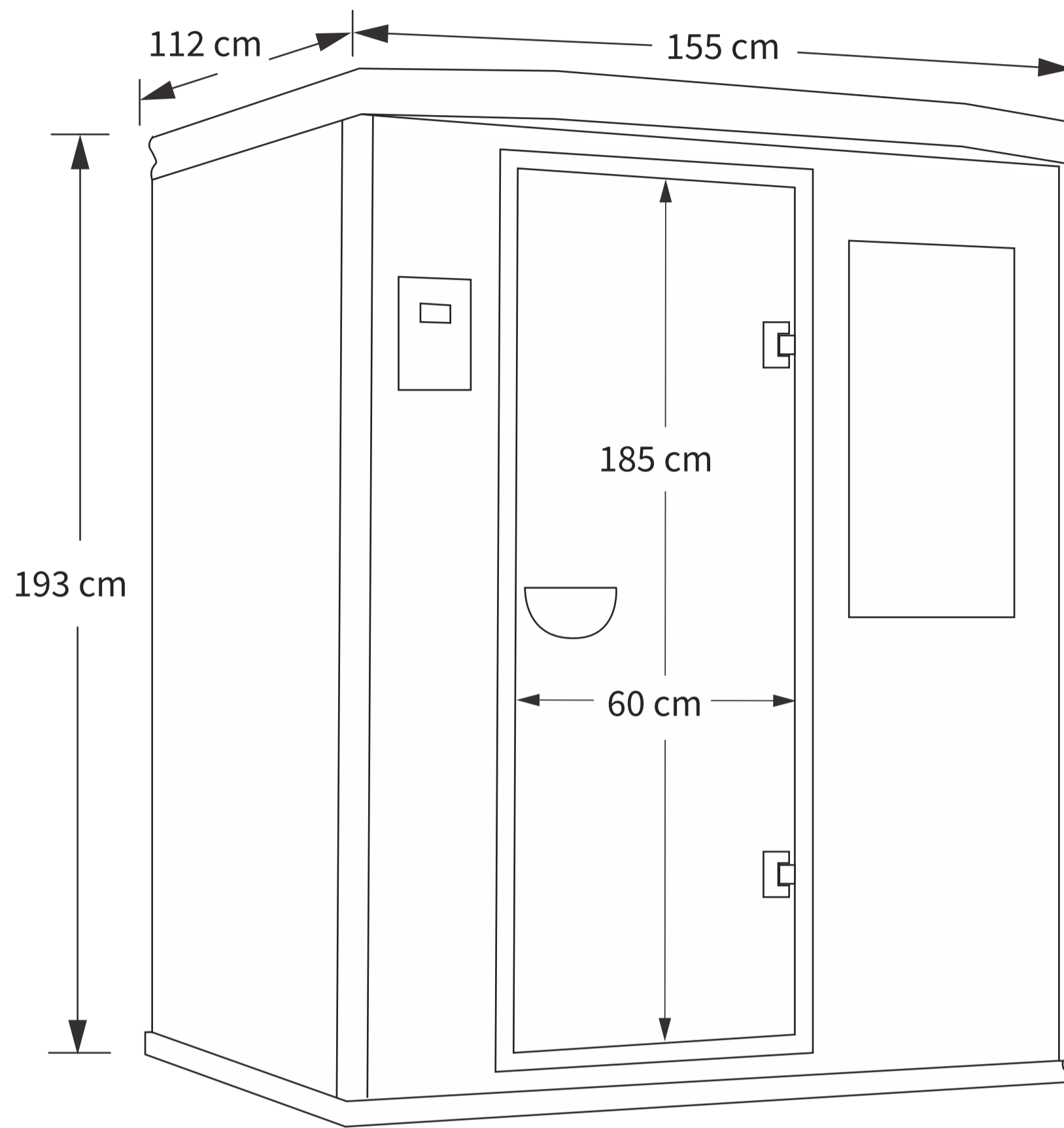

Specifications | IS-3

Dimensions & Weight	INTERIOR	EXTERIOR	WEIGHT
	Width	142 cm	Width 155 cm
Depth	102 cm	Depth 112 cm	
Height	180 cm	Height 193 cm	
Bench	137 x 56 cm		

- Installation Requirements**
- Choose a location with a flat, level surface
- Allow **5 cm** clearance on the sides and at the rear of your sauna
 - Allow **30 cm** of space above the sauna roof
 - Ensure access to the powerpoint at all times, to allow for hard reset
 - Check your sauna specs for required power amperage

Since every location is different, it's a great idea to connect with your sales consultant. They can provide valuable guidance in choosing the perfect sauna model for your specific space. A pre-install site inspection may also be possible, depending on your location.

Heaters

True Wave™ Carbon & Ceramic Low EMF/ELF Heaters:
Far Infrared heaters on the back wall, side walls, under the bench and in the floor.

Power & Electrical Specs

230 V
1,850 W
8.4 A
The sauna uses a standard 16 A household plug

Design

Eco Certified Grade "A" Hypoallergenic Western Red Cedar
Zero volatile organic compounds
6mm tempered safety glass door, window and ceiling
Double wall tongue and groove construction

Warranty

Your Clearlight® sauna comes with another exclusive – the Clearlight Infrared® Saunas Lifetime Warranty for residential use.

For legal reasons we have to call it a Limited Lifetime Warranty. Why "Limited"? We cover parts and shipping for the entire lifetime, however labour is not included for a lifetime. We do however provide the parts and pay for shipping, and we will also provide instructions on how to resolve possibly issues with your sauna.

EU

Clearlight Saunas Europe GmbH
+49 (0) 4040 110 162
info@clearlightsaunas.eu
www.clearlightsaunas.eu