

EQUIPMENT NEEDED

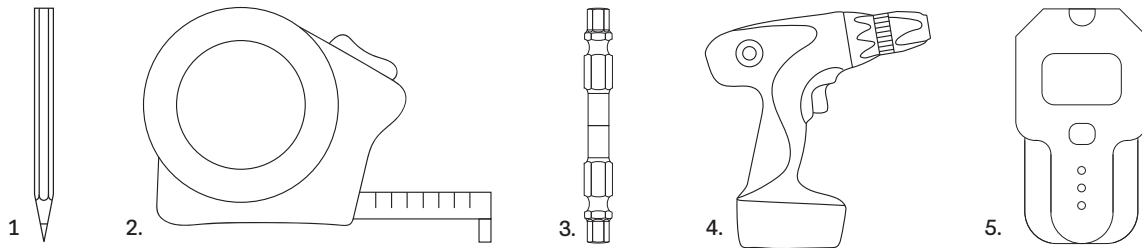

1. Pencil | 2. Tape Measure | 3. Hex Drill Bit | 4. Drill | 5. Stud Finder (optional)

SCULPTURE PARTS

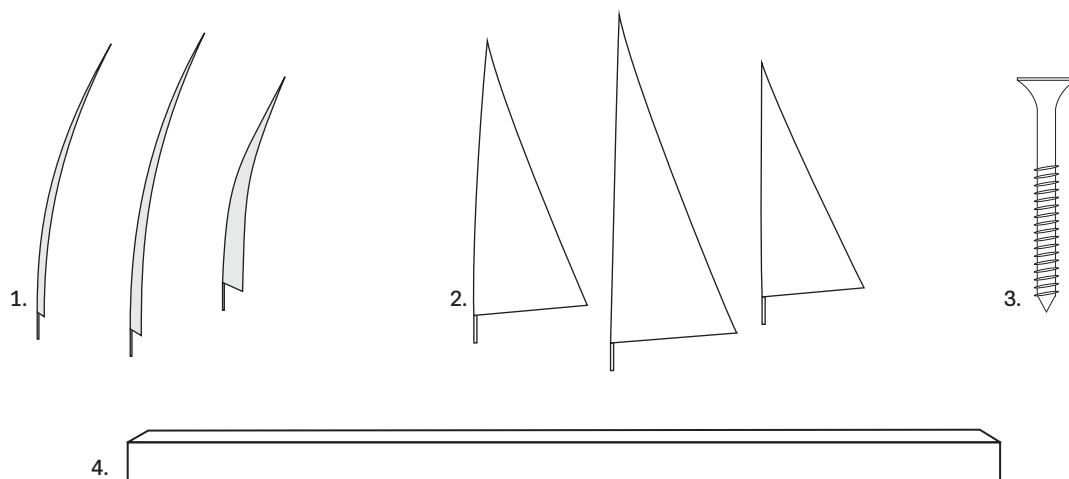

1. 3x Jib Sails | 2. 3x Main Sails | 3. 2x Bugle Screws | 4. Base

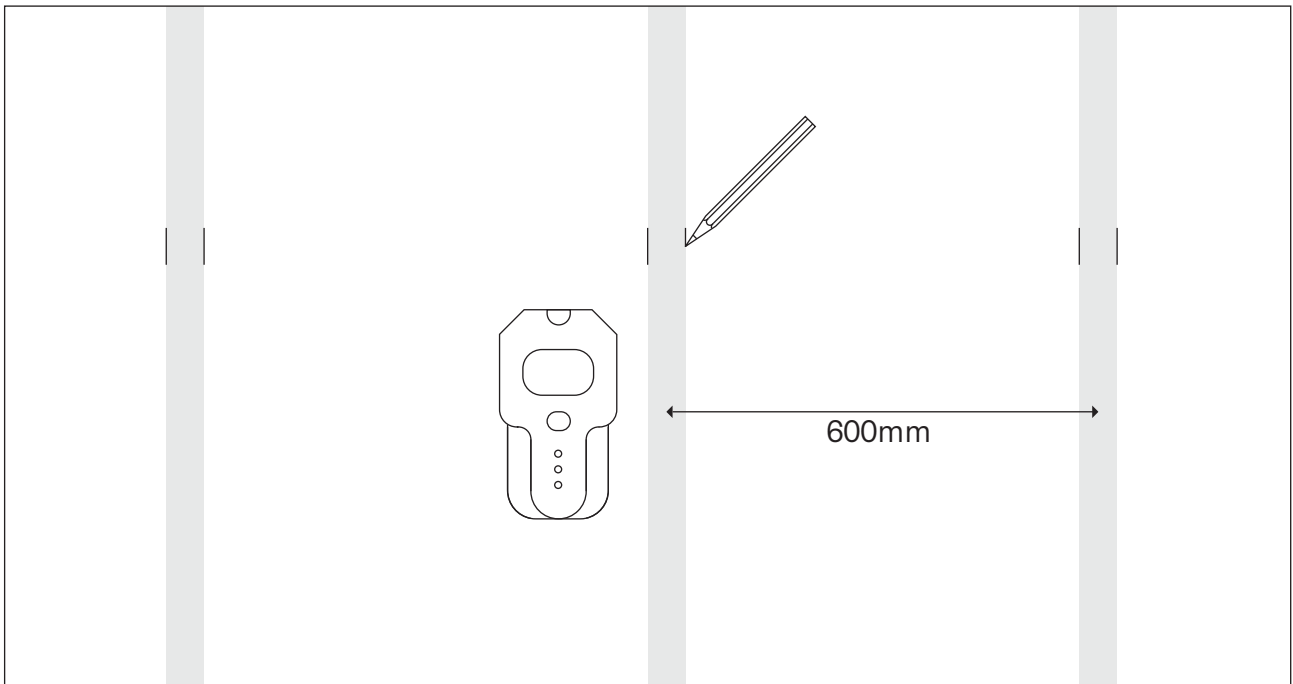

Using a stud finder, mark where the studs are in your wall around the area you want to mount the sculpture. Each stud should be about 600mm apart. If you do not have a stud finder, you can tap on the wall until you hear a 'muffled' sound.

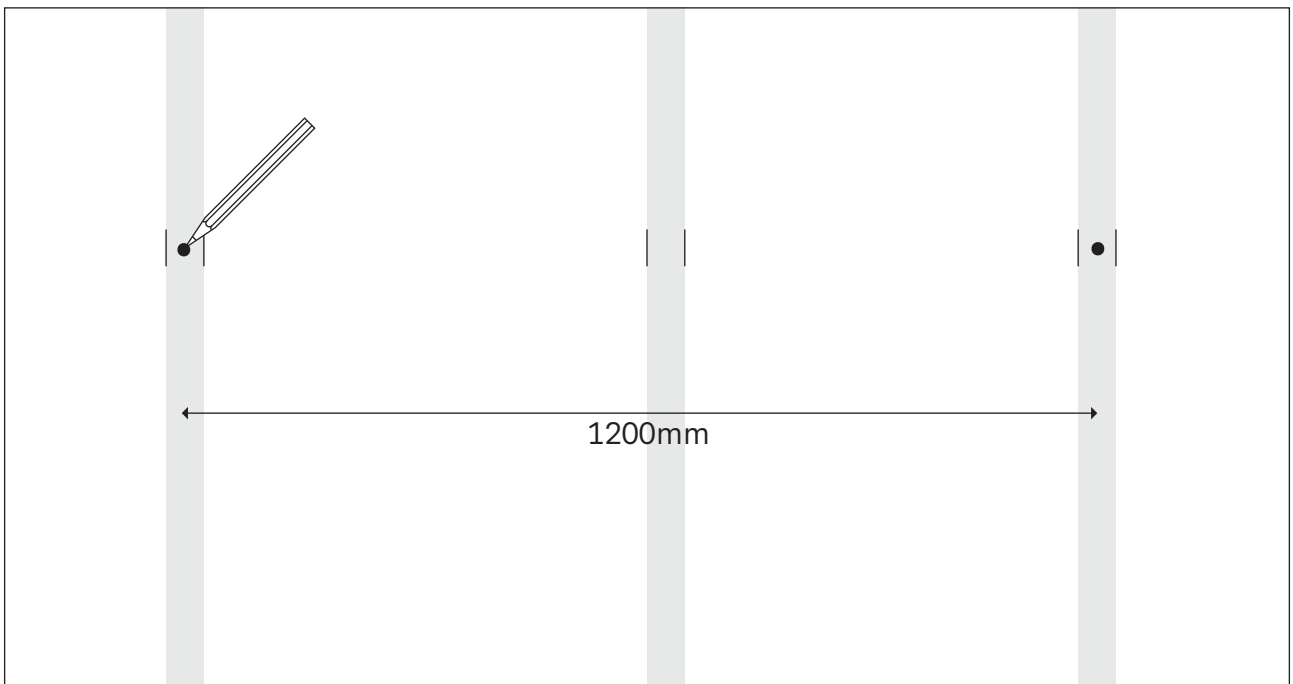

Using a tape measure, measure and mark two points on your wall, 1200mm apart. By choosing to place these two points over the studs you will be adding strength to the fixture of the sculpture as well as avoiding electrical cables.

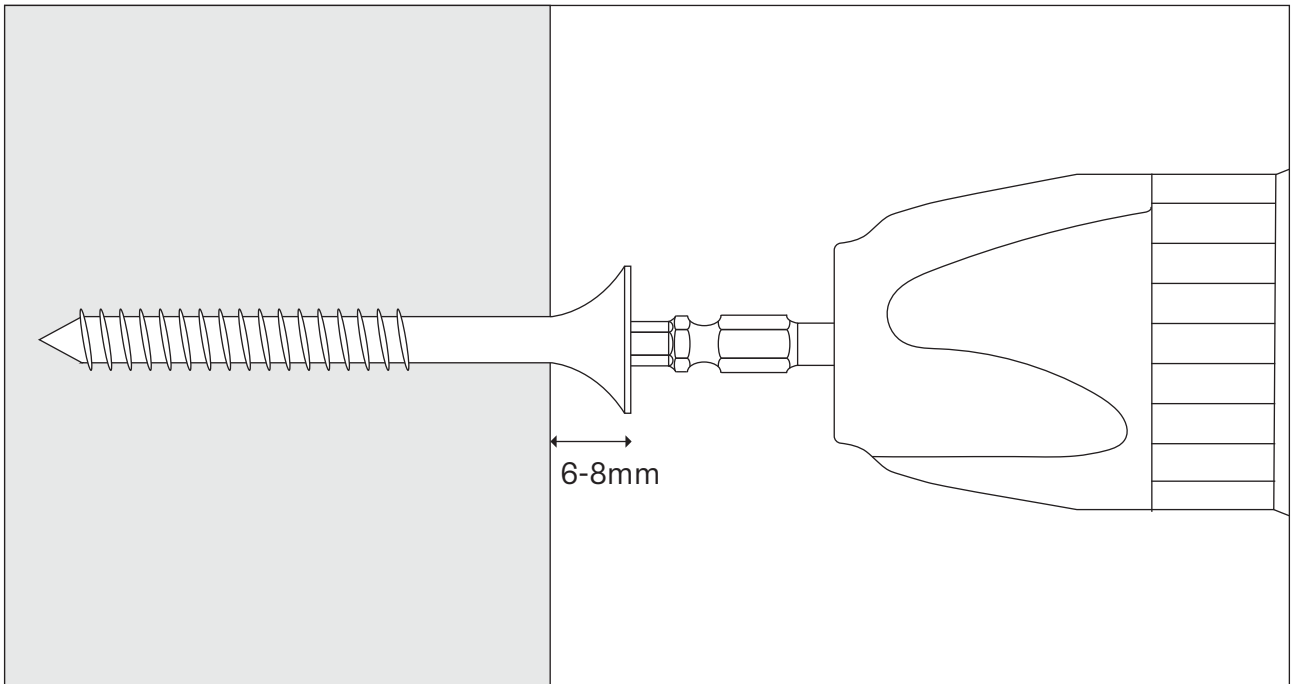

Using a hex drill bit, drill the bugle screws into the marked points on your wall, ensuring that the screws protrude about 6-8mm out of the wall.

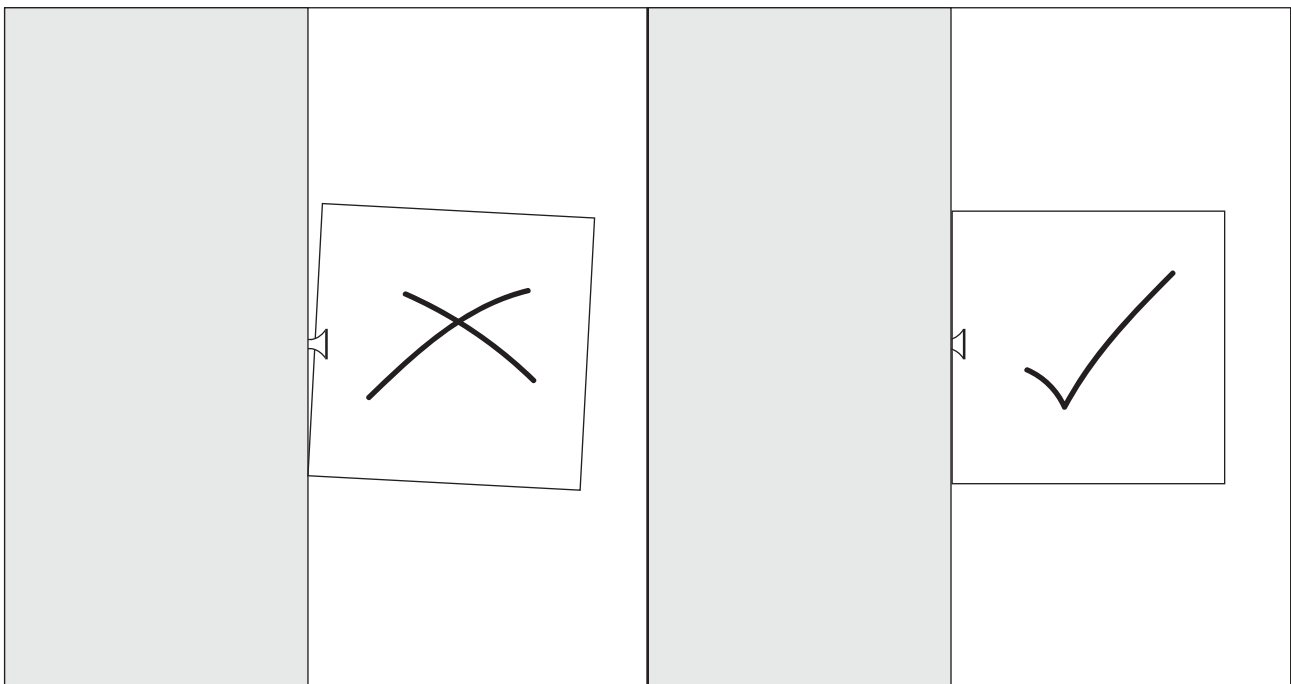

Place the base of the sculpture over the two screws, aligned with the holes in the back of the base. Then slide the base to the left to lock it into place. If the base is not tight against the wall, you will need to adjust the depth of the screws.

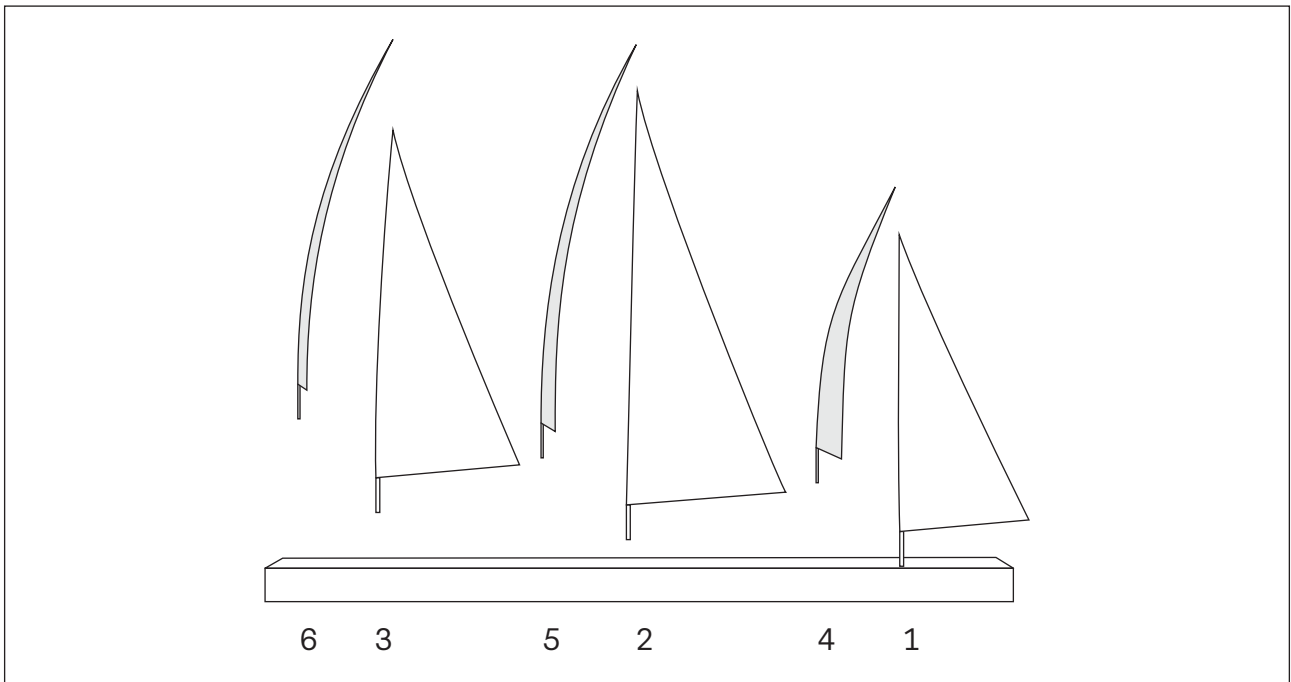

Remove the base off the wall. Screw in the sailing pieces by hand, following the order shown in the diagram.

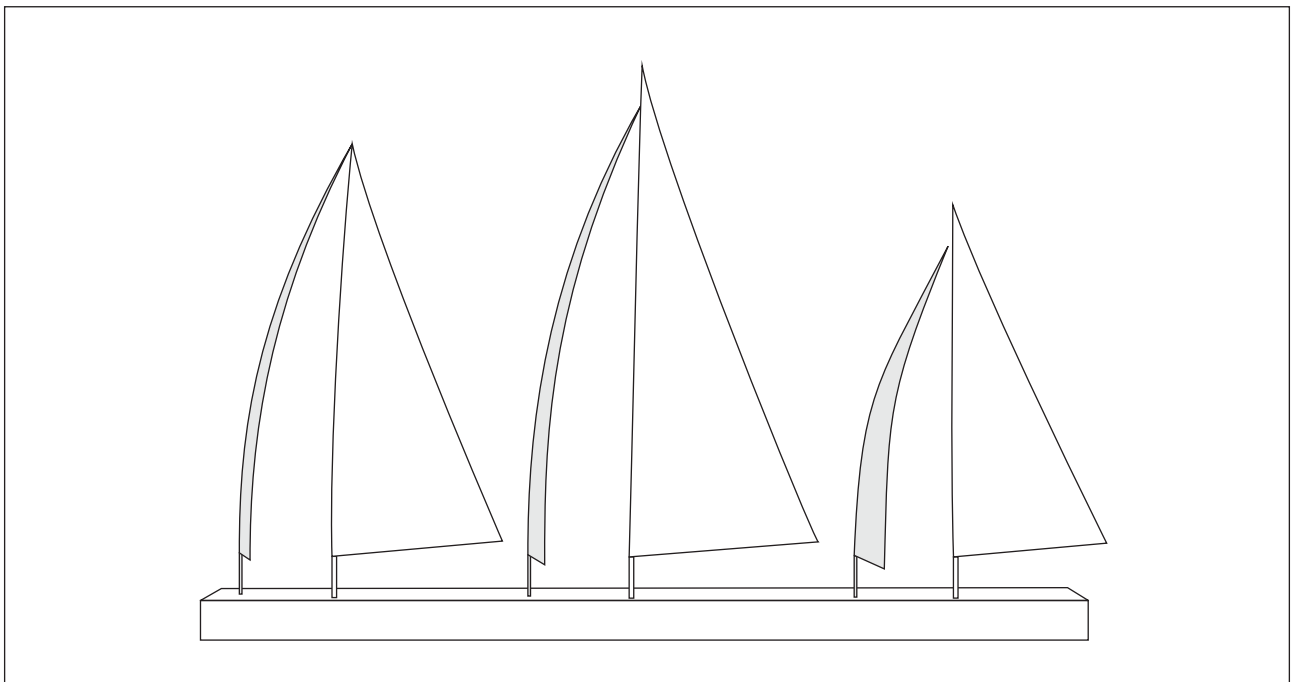

Once the sculpture is assembled you can hang it back on the wall. Make sure to slide it to the left to lock it into place so it won't fall off the wall.