

EQUIPMENT NEEDED

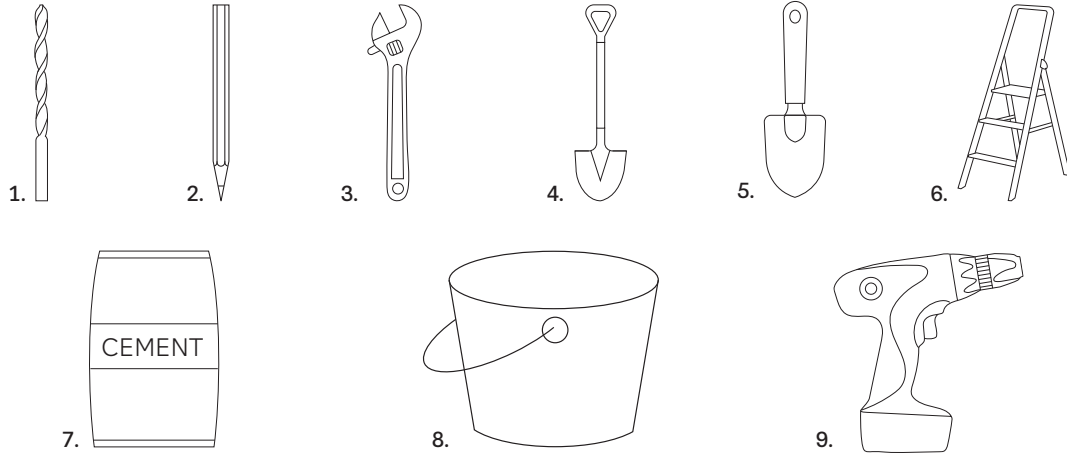

1. 120mm x 10mm Masonry Drill Bit | 2. Pencil | 3. Adjustable Wrench |
4. Large Spade | 5. Small Spade | 6. Step Ladder | 7. 60-80kg Cement |
8. Large Bucket | 9. Hammer Drill

SCULPTURE PARTS

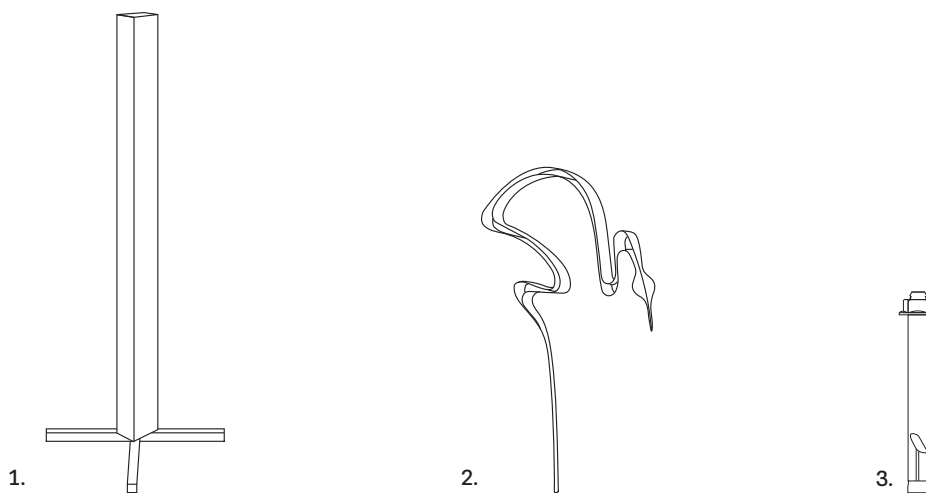

1. Base | 2. Birds | 3. 4x DynaBolt - M10 x 100mm

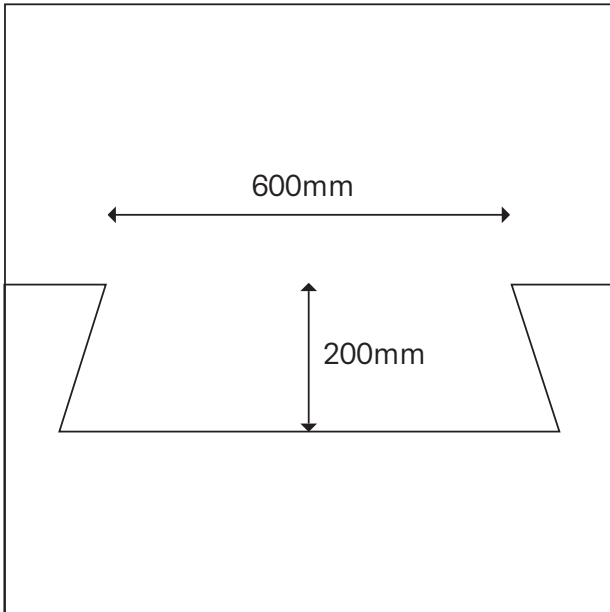

Dig a hole with a large spade 200mm deep and 600mm in diameter. We recommend digging the hole in a slight bell shape, as shown in diagram.

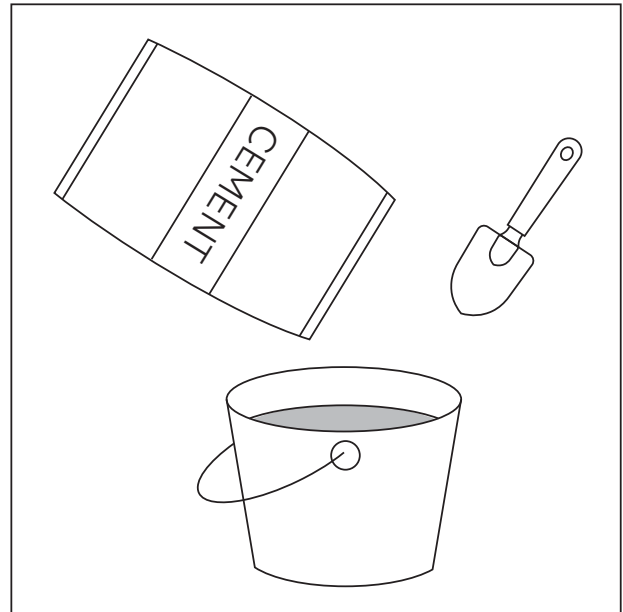

Prepare cement, following the bag's instructions. Use a large bucket and small spade to mix.

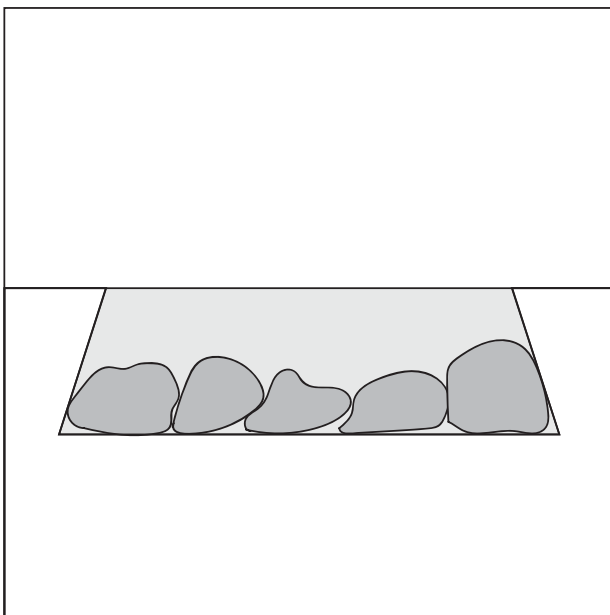

Fill hole with concrete. You may choose to add some rocks at the bottom to save on concrete.

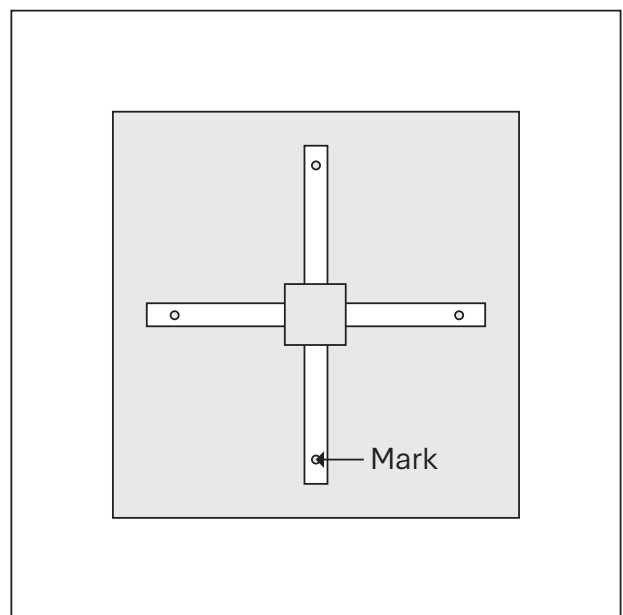

Once concrete is set, place the sculpture base on top of the concrete pad. With a pencil, mark where the four holes in the metal cross meet the concrete.

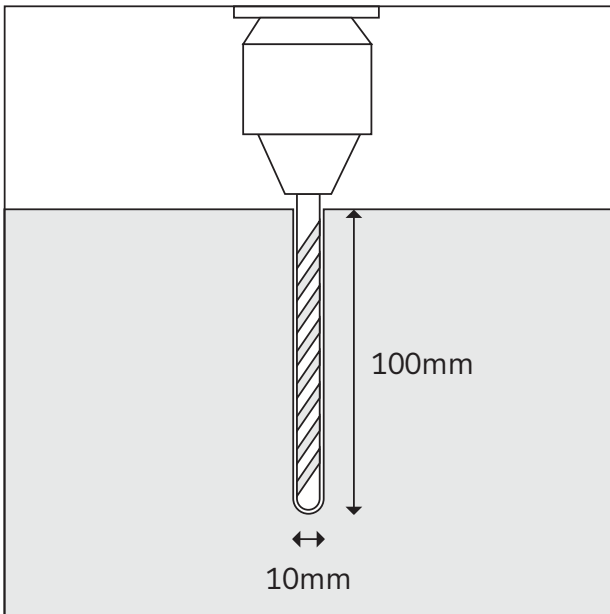

Remove the base. Drill four 10mm diameter holes, 100mm deep.

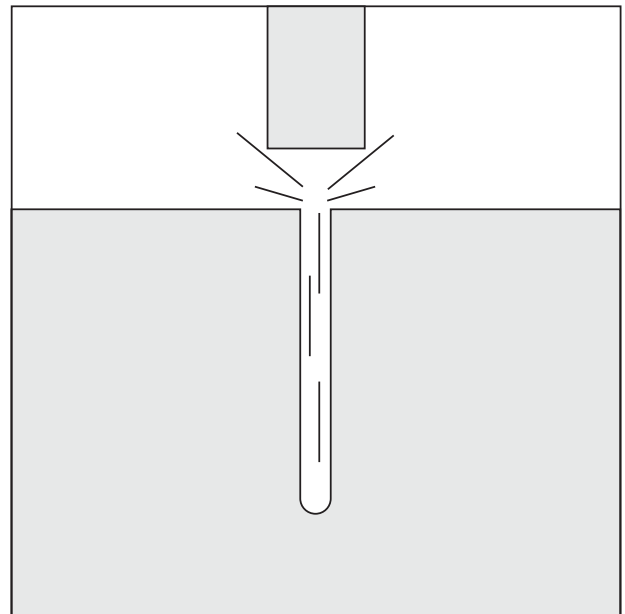

Remove debris by way of a vacuum or hand pump, compressed air, ect.

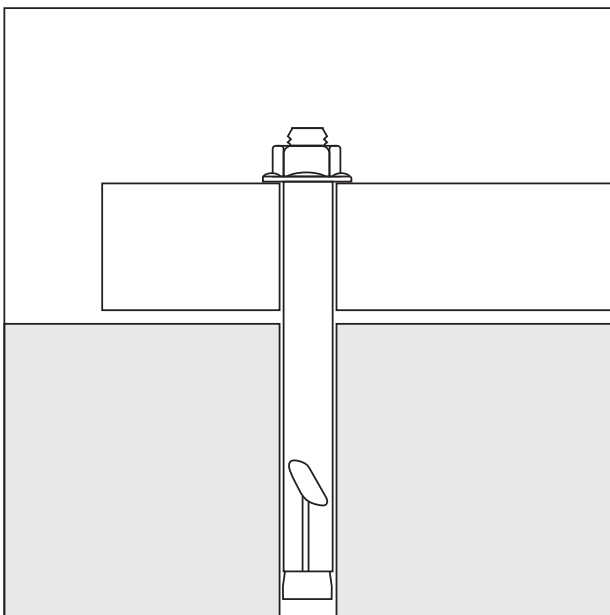

Place base back on concrete pad, lining up with the drilled holes. Insert the bolt and tighten with an adjustable spanner.

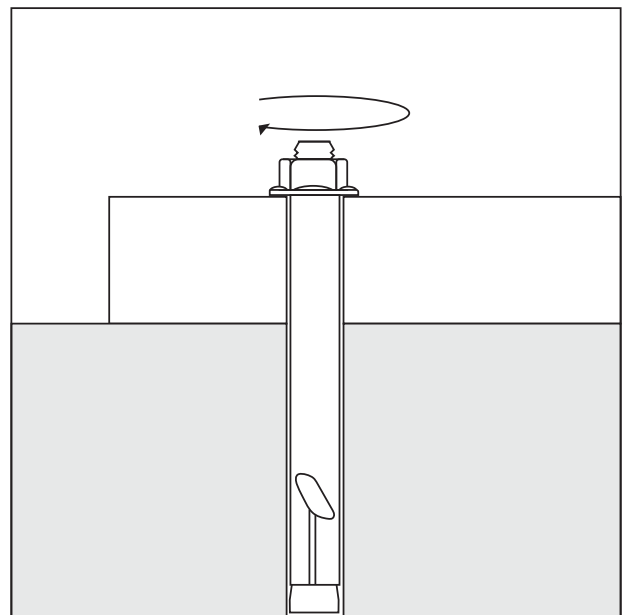

Continue tightening, allowing the sleeve to twist and pull down the base firmly into the concrete pad.

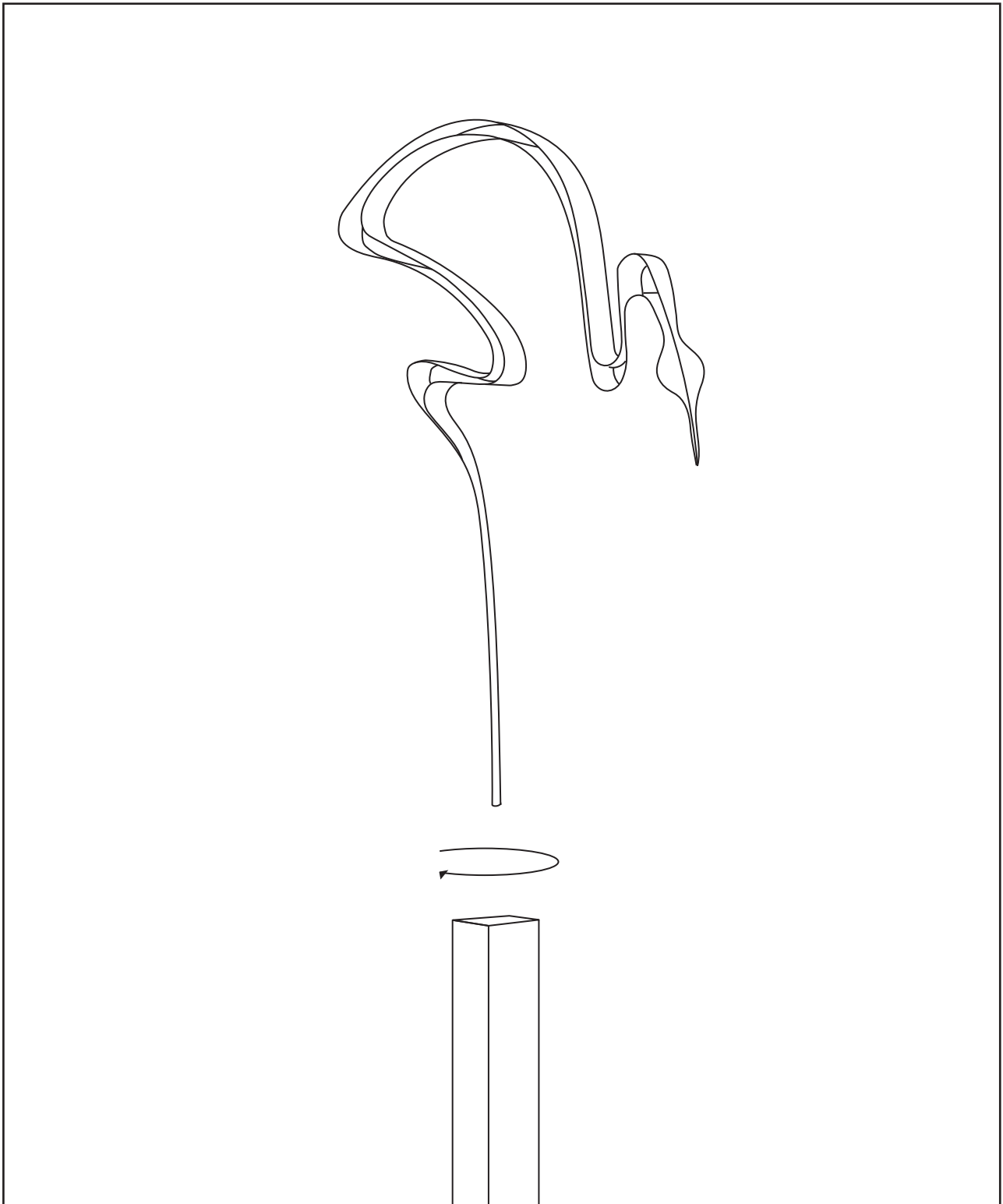

Once the base is firmly set into the ground, you can place the birds on top. You will need a step ladder for this part. Twist the bird by hand into the base until tight, the thread is about 30mm. Twist the birds into whichever position you like.