

# XCT80\_Y 汽车起重机 / Truck Crane

## 技术规格书

Technical Specifications

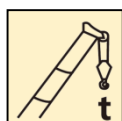

80t

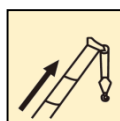

45.5 m

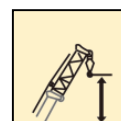

60.9 m



# 目录

## Contents

### 目录

#### Contents

|   |       |
|---|-------|
| 尺寸参数<br>Dimensions                            | 3-4   |
| 技术规格<br>Technical specifications              | 5-10  |
| 重量/作业速度<br>Weight / Working speeds            | 11    |
| 臂架组合方案<br>Boom / Jib combinations             | 12    |
| 主臂<br>Boom                                    | 13-15 |
| 副臂<br>Jib                                     | 16-17 |
| 注意事项<br>Notes                                 | 18    |
| 符号标识<br>Description of symbols                | 19    |
| 主要技术参数表<br>Table of main technical parameters | 20-21 |

# 尺寸参数 (右驾 Right-hand drive)

## Dimensions

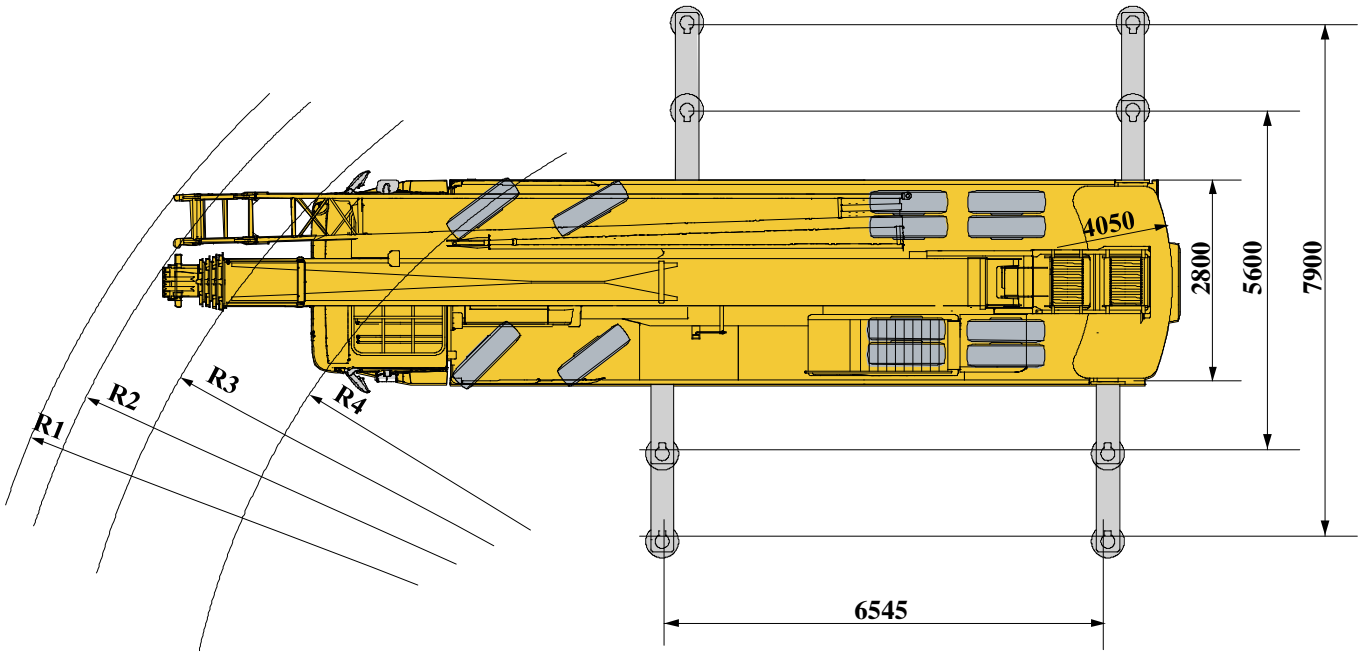
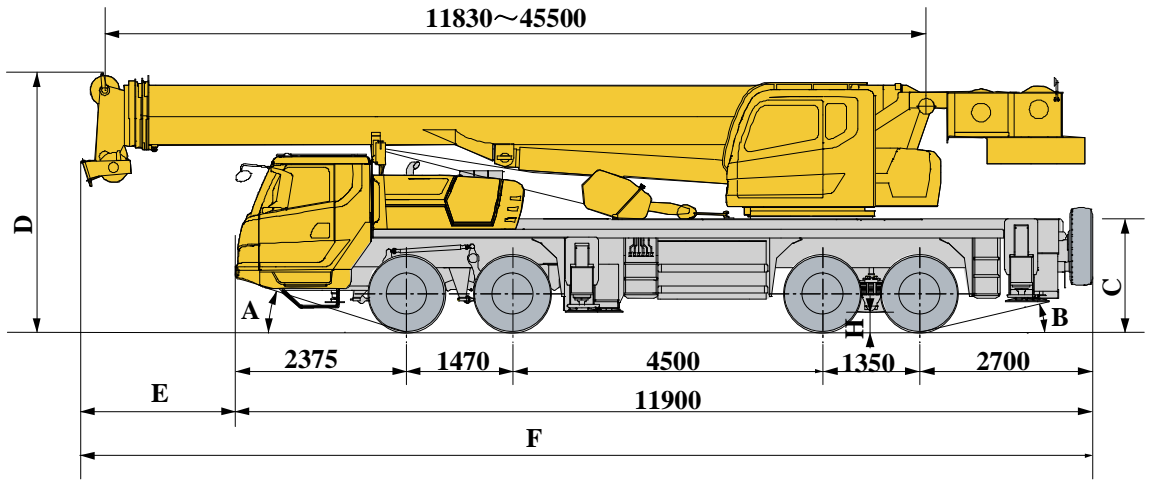

|  | A   | B   | C    | D    | E    | F     | R1    | R2    | R3    | R4    | H   |
|---|-----|-----|------|------|------|-------|-------|-------|-------|-------|-----|
| 12.00R24  | 22° | 13° | 1725 | 3770 | 1690 | 14085 | 14500 | 14100 | 13500 | 12000 | 305 |

# 技术规格

## Technical specifications

|  底盘   | 配置 |
|---|----|
| <b>车架</b> 徐工设计、制造，全覆盖式走台板，防扭转箱型结构，高强度钢材制造。  | ●  |
| <b>支腿</b> 4支腿，带第五支腿。纵向H形布置，双级水平支腿，操作杆控制液压动作。可由底盘任意一侧同时或单独控制各支腿的动作，设有水平仪。带第五支腿，支腿油缸均设有单向阀，且垂直支腿带有双向液压锁。支脚盘尺寸：Φ450mm<br>最大起重量时支腿反力：700kN  | ●  |
| <b>发动机</b> 东风康明斯，直列、水冷、四冲程、增压中冷、高压共轨；<br>QSL8.9-C360-30，额定功率264kW/2100rpm，最大扭矩1500Nm/1100-1500rpm，EU Stage IIIA、BS-III排放标准；<br>燃油箱容积：300L。<br>中国重型汽车集团，直列、水冷、四冲程、增压中冷、高压共轨；<br>WD615.334，额定功率247kW/2200rpm，最大扭矩1350Nm/1100-1600rpm，国三排放标准；<br>燃油箱容积：300L。 | ●  |
| <b>变速箱</b> 采用陕齿10JSD140TB机械式变速箱，手动远距离软轴操纵，全同步器；10个前进档，2个倒档，工作稳定、可靠。   | ●  |
| <b>车桥</b> 高强度桥，性能可靠。  | ●  |

|             |   |   |
|-------------|---|---|
| <b>悬挂</b>   | 后悬挂系统，采用V型推力杆结构、橡胶悬架，增加底盘行驶稳定性，减少轮胎的磨损。   |   |
| <b>轮胎</b>   | 12.00R24，行驶噪音低，承载力强。  | ● |
| <b>制动</b>   | 行车制动：脚踏板操纵的双回路气压制动。第一回路作用于一、二轴车轮上，第二回路作用于三、四轴车轮上。<br>驻车制动：弹簧储能制动，作用于二、三、四轴车轮上；<br>辅助制动：发动机缸内制动、排气制动，安全可靠，延长制动摩擦片使用寿命。 | ● |
| <b>转向</b>   | 机械式转向机构，带有液压助力。   | ● |
| <b>驾驶室</b>  | 豪华驾驶室。配备电动升降器的安全玻璃、可调式座椅、简易卧铺、电动调节后视镜、可调节高度及角度方向盘、液晶显示器和收放机等。标配冷暖空调。  | ● |
| <b>电气系统</b> | 直流24伏特，串联12伏特的电池组2个。<br>发电机：28±0.3伏特，70安培。  | ● |
| <b>安全装置</b> | 液压双向锁   | ● |
|             | 旋转报警灯   | ○ |
|             | 倒车影像  | ○ |
|             | ABS   | ○ |

# 技术规格

## Technical specifications

|  | 上车   | 配置 |
|--|--|----|
| <b>结构</b>  | 徐工设计、制造，高强度钢材制造。   | ●  |
| <b>液压系统</b>  | 底盘发动机驱动变量柱塞泵，用于起升、变幅、伸缩。负载敏感式比例多路换向阀，带有抗冲击阀、防气蚀阀；风冷式液压油散热器；              | ●  |
| <b>操纵方式</b>  | 液控先导操纵系统，由左右2个操纵手柄控制，由液压泵和比例阀进行液压先导式控制起重机的全部动作                           | ●  |
| <b>主起升机构</b>   | 液压控制调速，装有双折线绳槽卷筒，由液压马达通过行星齿轮减速器驱动，内置常闭式制动器并带有平衡阀；                        | ●  |
| <b>副起升机构</b>   | 液压控制调速，装有双折线绳槽卷筒，由液压马达通过行星齿轮减速器驱动，内置常闭式制动器并带有平衡阀；                        | ●  |
| <b>回转机构</b>  | 四点接触球式回转支承，由液压马达驱动行星齿轮回转机构减速器驱动，可连续回转360°；具有动力控制或自由回转的功能，可无级调速回转杆设有鸣响开关； | ●  |
| <b>变幅机构</b>  | 单支双作用前置液压变幅油缸，带有平衡阀。   | ●  |

|             |  |   |
|-------------|--|---|
| <b>操纵室</b>  | 新型钢制操纵室，装有无视野死角的前景窗，安全玻璃，车窗装有遮阳板，推拉式车门，座椅靠背可倾斜定位，操纵杆安装在座椅两侧的扶手台上；带推拉踏板；前窗顶窗装有雨刮器；标配单冷空调； | ● |
| <b>组合配重</b> | 总重5.3t，有5.3t和2.2t两种组合。   | ● |
| <b>安全装置</b> | 液压平衡阀；液压溢流阀；力矩限制器；操纵杆弹簧式回中系统；三圈保护器，防止钢丝绳过放；臂头设置高度限位，防止钢丝绳过卷；自由滑转；回转锁止                    | ● |
|             | 卷扬监视装置   | ○ |
|             | 三色报警灯  | ○ |
|             | 回转警示灯  | ○ |
| <b>起重钩</b>  | 80t吊钩  | ● |
|             | 4.5t吊钩   | ● |
|             | 35t吊钩  | ○ |

# 技术规格

## Technical specifications

|  臂架系统     | 配置 |
|---|----|
| <b>主臂</b><br>由1节基本臂和4节伸缩臂组成，采用U形截面的筒形焊接结构、抗扭曲设计，高强度结构钢制造。单缸绳排伸缩机构。<br>主臂长度：11.83m ~ 45.5m | ●  |
| <b>侧置副臂</b><br>2节桁架式焊接结构，具有0°、15°、30°三种固定副臂安装角<br>固定副臂长度：9.5m/16m                         | ●  |
| <b>臂端单滑轮</b><br>单滑轮，安装在主臂顶端用于单股钢丝绳起重作业，起重性能与主臂相同，但最大起重量不超过4.5t。                           | ●  |

产品各部件明细如上所述，具体部件明细请参照产品报价单

符号说明：

- —— 表示标准配置；
- —— 表示选装配置。

# 技术规格

## Technical specifications

|  Chassis | Configuration   |   | Axles   | ● |
|--|---|---|---|---|
| <b>Frame</b>   | Designed and manufactured by XCMG, it is made of high strength steel with fully covered walking surface and anti-torsion box-typed structure.   | ● | <b>Suspensions</b> Rubber spring suspensions with V-type push rods are adopted for rear suspension system, leading to improved chassis stability and reduced tire wear.   | ● |
| <b>Outriggers</b>  | Four outrigger arranged, with 5th jack is available. Four outriggers arranged in H-shape are hydraulically controlled by control levers. Double-stage outrigger beam is adopted. There is an outrigger control station located at each side of the chassis, and there is a level gauge on each control station. The outrigger movements can be simultaneously or separately controlled at any side of the chassis. With 5th jack is available. There is a check valve fitted in each outrigger cylinder, and a double-way hydraulic valve fitted in each jack cylinder.<br>Outrigger float diameter: φ450 mm<br>Reaction force of outrigger at max. lifting load: 700kN | ● | <b>Tires</b> 12.00R24, low noise during traveling and strong bearing capacity .   | ● |
| <b>Engine</b>  | Dongfeng Cummins, In line, water cooled, four-stroke, supercharging, high pressure common rail QSL8.9-C360-30, with rated power of 264kW/2100rpm and max. torque of 1500Nm/1100-1500rpm, compliant to EU Stage IIIA、BS-III standard.<br>Fuel tank capacity: 300L.<br>CHINA NATIONAL HEAVY DUTY TRUCK GROUP, In line, water cooled, four-stroke, supercharging, high pressure common rail  | ● | <b>Braking</b> Service braking: foot pedal operated double-circuit air pressure brake. 1st circuit acts on the wheels of 1st and 2nd axles, and 2nd circuit acts on the wheels of 3rd and 4th axles.<br>Parking brake: spring-loaded brake, acting on wheels of axles 2,3 and 4;<br>Auxiliary brake: engine exhaust brake, which is safe and reliable, and will prolong the service life of brake lining. | ● |
|  | WD615.334, with rated power of 247 kW/2200 rpm and max. torque of 1350 Nm/1100-1600 rpm, compliant to China III emission standard.<br>Fuel tank capacity: 300L.   | ○ | <b>Steering</b> Mechanically steering mechanism with a hydraulic booster.   | ● |
| <b>Transmission</b>  | Mechanical transmission 10JSD140TB, made by Shaanxi Fast Gear Co., Ltd., manual flexible shaft control, 10-forward speed and 2-reverse speed with a synchronizer.   | ● | <b>Driver's cab</b> Luxurious driver's cab. Safety glass, electrically operated door window lifters, adjustable seats, electrical adjustable mirrors, steering wheel adjustable in height and angle, liquid crystal display and radio-cassette player are equipped. Heater and air conditioner are standard.  | ● |
|  |   |   | <b>Electrical system</b> 24V DC, two sets of 12 V battery in series.<br>Generator: 28±0.3 V-70 A  | ● |
|  |   |   | <b>Safety devices</b> Double-way hydraulic valve  | ● |
|  |   |   | Beacon lamp   | ○ |
|  |   |   | Backup camera   | ○ |
|  |   |   | ABS   | ○ |

# 技术规格

## Technical specifications

|  | Superstructure   | Configuration | Operator's cab   |                               |
|--|--|---------------|--|-------------------------------|
| <b>Frame</b>   | Designed and manufactured by XCMG, made of high strength steel.  | ●             | New steel cab with a full-view windshield, safety glass, sun shield and adjustable operator's seat. Windshield wiper and roof window wiper are fitted. Crane control levers are integrated into armrests. A sliding door and a pull-out step are designed for easy and safe access to the cab. Air conditioning is standard. | ●                             |
| <b>Hydraulic system</b>  | Variable pump driven by chassis engine, used for hoisting, elevating and telescoping operations. Load sensing proportional multi-way change valve with impact resistance valve and cavitation-proof valve integrated; air-cooled hydraulic oil radiator.   | ●             |  | <b>Combined counterweight</b> |
| <b>Operating mode</b>  | Pilot hydraulic control is used for controlling the superstructure. All crane movements are controlled by hydraulic pump and proportional valve through two control levers at left and right sides.  | ●             | <b>Safety devices</b>  | ●                             |
| <b>Main winch system</b>   | Hydraulic control is used for speed regulation. The system is driven by a hydraulic motor through a planetary gear reducer, with a normally closed brake, a balance valve and a grooved drum equipped.   | ●             | Hydraulic balance valve, hydraulic relief valve, LMI, spring centering system for control levers, lowering limiter for preventing wire rope from over-releasing, and anti-two block at boom head for preventing wire rope from over-winding. Free sliding, slewing locking.  |                               |
| <b>Auxiliary winch system</b>  | Hydraulic control is used for speed regulation. The system is driven by a hydraulic motor through a planetary gear reducer, with a normally closed brake, a balance valve and a grooved drum equipped.   | ●             | Winch monitoring device  | ○                             |
| <b>Slewing system</b>  | Four-point contact-ball slewing ring is driven by the planetary gear reducer of slewing mechanism, which is driven by a hydraulic motor, and may continuously slew 360°. Power control and free slewing function as well as stepless speed regulation are available. There is a horn switch fitted on the slewing control lever. | ●             | Tri colored light bar  | ○                             |
| <b>Elevating system</b>  | A front support double-acting hydraulic cylinder is equipped for elevating operation, with a balance valve fitted.   | ●             | Beacon lamp for slewing  | ○                             |
|  |  |               | <b>Hook block</b>  | ●                             |
|  |  |               | 80t hook block   | ●                             |
|  |  |               | 4.5t hook block  | ●                             |
|  |  |               | 35t hook block   | ○                             |

# 技术规格

## Technical specifications

|  Boom and jib system   | Configuration |
|--|---------------|
| <b>Boom</b><br>Comprised of one basic boom and four telescoping boom sections, with U-shaped cross-section, welded structure and adopts anti-distortion design and is made of high strength structural steel. Single-cylinder plus ropes telescoping system<br>Boom length: 11.83m~45.5m | ●             |
| <b>Swing-away jib</b><br>Two-section lattice jib, welded structure. Three offset angles of 0°, 15° and 30°.<br>Fixed jib length: 9.5m~16m.   | ●             |
| <b>Single top</b><br>Installed at the boom top, used for single line operation. Its lifting performance is the same as that for boom, but the max. lifting load could not exceed 4.5t.   | ●             |

Product parts list is as mentioned above. Please refer to the product quotation for specific parts.

Symbol explanation:

- —it means the standard configuration;
- —it means the optional configuration.

## 重量 Weight



| 车桥<br>Axle | 1  | 2  | 3  | 4  | 总重量<br>Total weight |
|------------|----|----|----|----|---------------------|
| t          | 10 | 10 | 13 | 13 | 46                  |



| 吊钩<br>Hook | 倍率<br>Parts of lines | 吊钩重量<br>Weight (kg) | 吊钩尺寸<br>Dimensions (mm) | 备注<br>Remarks                |
|------------|----------------------|---------------------|-------------------------|------------------------------|
| 80t        | 13                   | 616                 | 1325×544×537            | 单钩 Single hook , 标配 Standard |
| 35t        | 6                    | 370                 | 1427×570×308            | 单钩 Single hook , 选装 optional |
| 4.5t       | 1                    | 100                 | 536×298×298             | 单钩 Single hook , 标配 Standard |

## 作业速度 Working speeds



12.00R24



2~48 ( 印度市场 Indian market ) /  
2~90 ( 其它区域 other regions )



40%



作业机构  
Drive

作业速度  
Working speed

最大单绳拉力  
Max. single line pull

钢丝绳直径/长度  
Rope diameter/ length



0-145 m/min , 单绳 , 第四层  
m/min, single line, 4th layer

6.5t

20 mm/230m



0-90 m/min , 单绳 , 第四层  
m/min, single line, 4th layer

6.5t

20mm/145m



0-2r/min



从-1°抬起至81°约55s  
Approx. 55s for boom elevation from -1° to 81°



从11.83m伸出至45.5m约110s  
Approx. 110s for boom extension from 11.4m to 43.5m

## 臂架组合方案

### Boom / Jib combinations



主臂  
Telescopic boom

T : 11.83~45.5m

副臂  
Jib

T : 45.5m  
J : 9.5m/16m

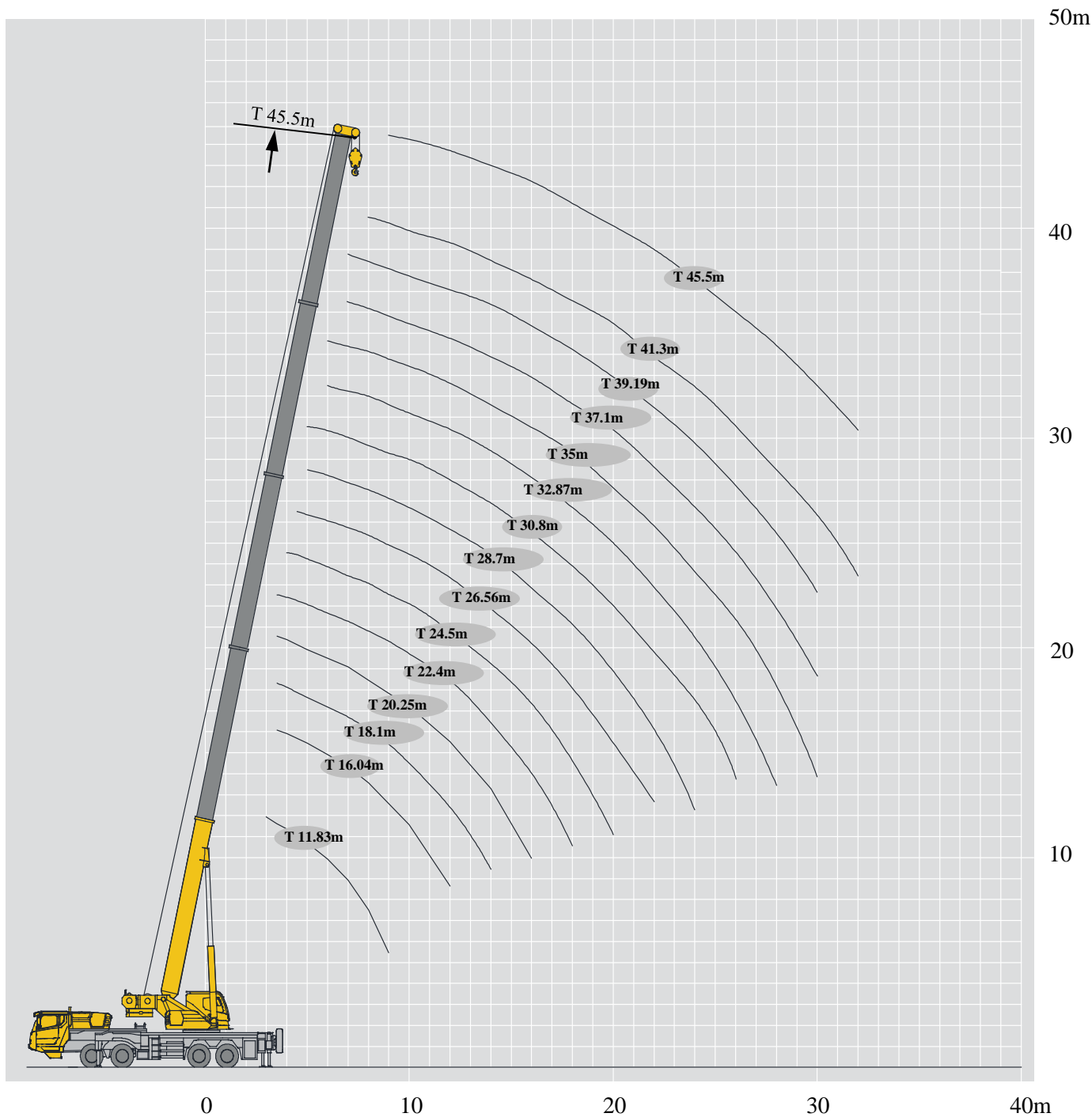

# 起重性能表

## Lifting capacities

T 11.83~45.5m

| m   | 11.83-45.5m |       | 6.545m×7.9m |       | 360° |      | 5.3t  |      |      |       |      |      |       |      |      |  |     |  | m |
|-----|-------------|-------|-------------|-------|------|------|-------|------|------|-------|------|------|-------|------|------|--|-----|--|---|
|     | 11.83       | 16.04 | 18.1        | 20.25 | 22.4 | 24.5 | 26.56 | 28.7 | 30.8 | 32.87 | 35   | 37.1 | 39.19 | 41.3 | 45.5 |  |     |  |   |
| 3   | 80          |       |             |       |      |      |       |      |      |       |      |      |       |      |      |  | 3   |  |   |
| 3.5 | 75          | 55    |             |       |      |      |       |      |      |       |      |      |       |      |      |  | 3.5 |  |   |
| 4   | 65          | 55    |             |       |      |      |       |      |      |       |      |      |       |      |      |  | 4   |  |   |
| 5   | 52          | 50    | 31          | 40    | 30   | 29.5 |       |      |      |       |      |      |       |      |      |  | 5   |  |   |
| 6   | 44          | 42    | 31          | 36    | 30   | 27.2 | 30    | 29.2 | 19.9 | 22.5  |      |      |       |      |      |  | 6   |  |   |
| 7   | 36.5        | 35    | 30.5        | 32.5  | 30   | 25.1 | 28    | 28.3 | 18.5 | 21.4  | 18.4 | 14.0 | 15.5  |      |      |  | 7   |  |   |
| 8   | 27.5        | 27.2  | 28.8        | 26.9  | 29   | 23.6 | 25.5  | 26.5 | 17.2 | 19.8  | 17.4 | 13.6 | 15.3  | 11.6 | 9.8  |  | 8   |  |   |
| 9   | 21.7        | 21.4  | 23.7        | 21.1  | 23   | 22.4 | 22.6  | 24   | 16.2 | 18.4  | 16.4 | 12.9 | 14.5  | 11.6 | 9.6  |  | 9   |  |   |
| 10  |             | 17.4  | 19.5        | 17.1  | 18.9 | 20.3 | 18.4  | 19.7 | 15.2 | 17.1  | 15.6 | 12.0 | 13.6  | 11.5 | 9.6  |  | 10  |  |   |
| 12  |             | 12.1  | 14.1        | 11.8  | 13.5 | 14.8 | 13.1  | 14.2 | 13.5 | 13.8  | 14.0 | 10.8 | 12.2  | 10.7 | 9.6  |  | 12  |  |   |
| 14  |             |       | 10.6        | 8.6   | 10.1 | 11.3 | 9.7   | 10.8 | 11.8 | 10.4  | 11.3 | 9.6  | 10.9  | 9.8  | 8.9  |  | 14  |  |   |
| 16  |             |       |             | 6.2   | 7.8  | 9    | 7.4   | 8.5  | 9.4  | 8.1   | 8.9  | 8.5  | 8.5   | 8.6  | 8.2  |  | 16  |  |   |
| 18  |             |       |             |       | 6.1  | 7.3  | 5.7   | 6.7  | 7.6  | 6.4   | 7.2  | 7.6  | 6.8   | 7.5  | 7    |  | 18  |  |   |
| 20  |             |       |             |       |      | 5.9  | 4.4   | 5.4  | 6.3  | 5     | 5.8  | 6.5  | 5.5   | 6.1  | 5.8  |  | 20  |  |   |
| 22  |             |       |             |       |      |      | 3.4   | 4.4  | 5.2  | 4     | 4.8  | 5.5  | 4.4   | 5.1  | 4.7  |  | 22  |  |   |
| 24  |             |       |             |       |      |      |       | 3.6  | 4.4  | 3.2   | 4    | 4.6  | 3.6   | 4.2  | 3.9  |  | 24  |  |   |
| 26  |             |       |             |       |      |      |       |      | 3.7  | 2.5   | 3.3  | 3.9  | 2.9   | 3.5  | 3.2  |  | 26  |  |   |
| 28  |             |       |             |       |      |      |       |      |      | 1.9   | 2.7  | 3.3  | 2.3   | 3    | 2.6  |  | 28  |  |   |
| 30  |             |       |             |       |      |      |       |      |      |       | 2.2  | 2.8  | 1.9   | 2.5  | 2.1  |  | 30  |  |   |
| 32  |             |       |             |       |      |      |       |      |      |       |      | 2.4  | 1.5   | 2    | 1.7  |  | 32  |  |   |
| 34  |             |       |             |       |      |      |       |      |      |       |      |      |       | 1.7  | 1.4  |  | 34  |  |   |

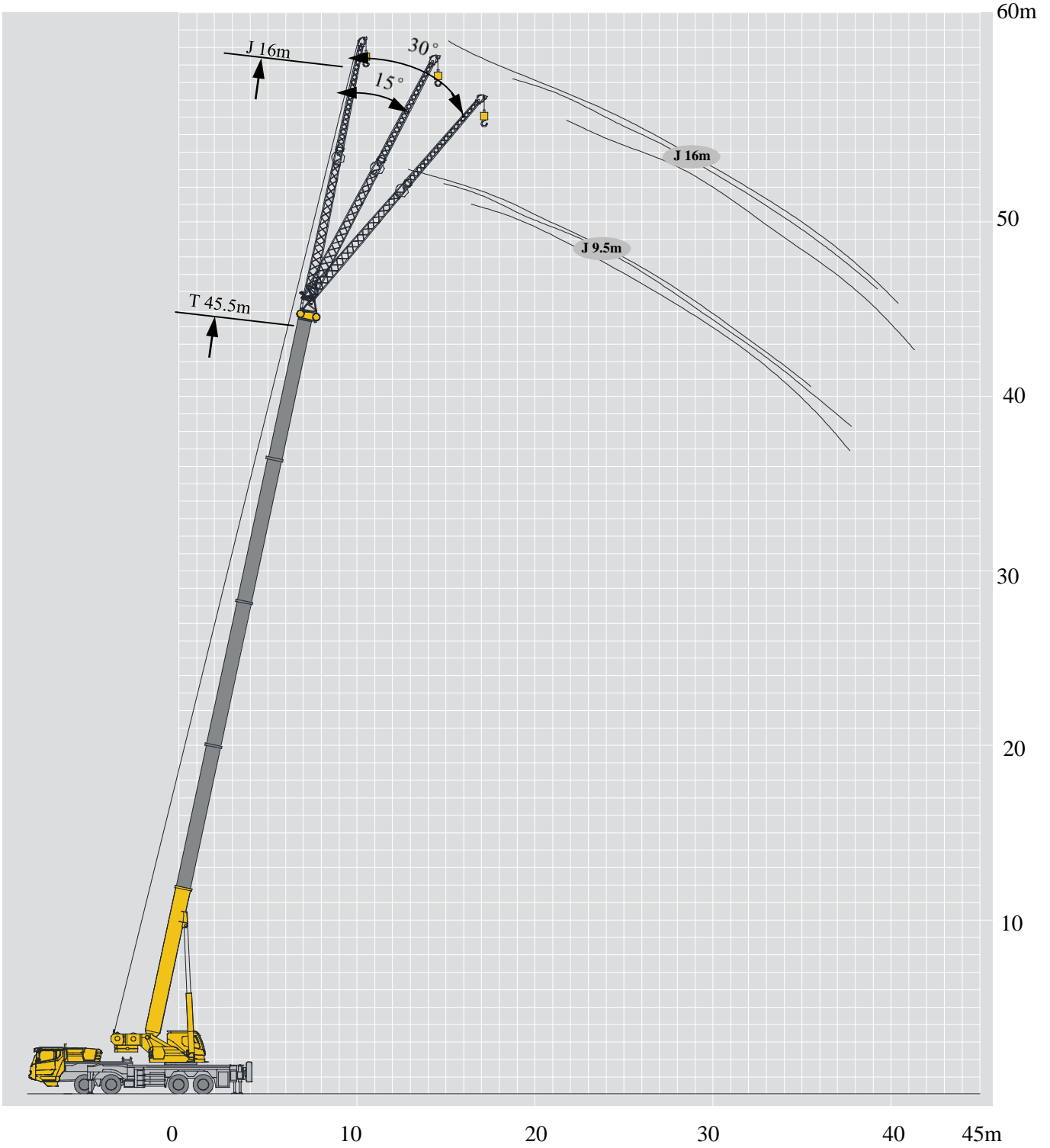

# 起重性能表

## Lifting capacities

T 45.5m

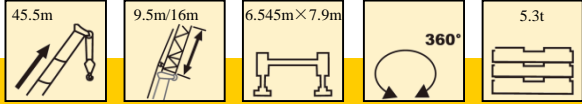

|     | 9.5m |     |     | 16m |     |     |     |
|-----|------|-----|-----|-----|-----|-----|-----|
|     | 0°   | 15° | 30° | 0°  | 15° | 30° |     |
| 80° | 4.5  | 4   | 3.2 | 2.9 | 2.4 | 1.3 | 80° |
| 78° | 4.2  | 3.8 | 3.2 | 2.9 | 2   | 1.1 | 78° |
| 75° | 4    | 3.7 | 3   | 2.8 | 1.6 | 1   | 75° |
| 72° | 3.8  | 3.5 | 2.7 | 2.5 | 1.4 | 0.9 | 72° |
| 70° | 3.6  | 3.2 | 2.6 | 2.2 | 1.2 | 0.9 | 70° |
| 65° | 2.6  | 2.4 | 2.2 | 1.6 | 1   | 0.9 | 65° |
| 60° | 1.7  | 1.6 | 1.5 | 1.2 | 0.9 | 0.8 | 60° |
| 55° | 1.2  | 1.1 | 1   | 0.9 | 0.8 | 0.7 | 55° |
| 50° | 0.7  | 0.7 | 0.7 |     |     |     | 50° |

## 注意事项

### Notes

1. 表中额定总起重量值，是在平整的坚固地面上本起重机能够保证的最大总起重量，包括吊钩和吊具的重量，所以为了估算重物重量，必须减去上述的装置重量。
2. 表中的工作幅度为起吊重物离地时起重物到起重机回转轴线的水平距离，是包括起重臂变形量在内的实际值，因而起吊前应考虑起重臂变形量。
3. 只允许在5级(瞬时风速14.1m/s，风压125N/m<sup>2</sup>)风以下进行作业。
4. 吊重前操作者必须对物体的重量和工作范围了解后选择合适的作业工况，严禁超出表中的数值。幅度及臂长在相邻两个数值之间时，应依据两个数值中较小值确定起重作业。
5. 应按主臂仰角范围作业，即使是空载，也不应使主臂仰角处于范围外，谨防整机倾翻。
6. 表中的主臂长度应要按照每节臂的伸缩要求进行伸出。

1. The total rated loads given in the rated load charts are the maximum lifting capacity when the crane is set up on firm and level ground, which includes the weight of the hook block and slings. The weight of above-mentioned devices should be deducted to correctly calculate the load weight.
2. The working radius shown in the rated load charts is the radius when the load is lifted off the ground, and it is the actual value including loaded boom deflection.
3. A lifting operation is permissible only when the wind force is below grade 5 (instantaneous wind speed is 14.1 m/s, wind pressure is 125 N/m<sup>2</sup>).
4. Before beginning lifting operation, the operator should know the weight of the load to be lifted and its working range, and then select proper working conditions. Never operate the crane beyond the limit shown in the chart. Use the lower value from the chart when the boom length or working radius is between the range of values.
5. Observe the boom angle limit. Never operate the crane with the boom angle beyond the recommended limit even if a load is not being carried. Otherwise, the crane will tip.
6. The boom length given in the rated load charts should accord with the telescoping code of boom sections .

# 符号标识

## Description of symbols

### 常规标识

#### General symbols

|  |  |   |                                       |
|--|--|---|---------------------------------------|
|    | 上车<br>Superstructure   |    | 底盘<br>Chassis                         |
|    | 起重能力<br>Lifting capacity                                       |    | 车桥<br>Axle                            |
|    | 吊臂长度<br>Boom length  |    | 行驶速度<br>Driving speed                 |
|    | 工作幅度<br>Radius   |    | 爬坡能力<br>Grade ability                 |
|    | 吊臂仰角<br>Boom angle   |    | 轮胎<br>Tires                           |
|   | 主臂起升高度<br>Hoist height with boom                               |   | 支腿<br>Outriggers                      |
|  | 固定副臂长度<br>Fixed jib length                                     |  | 吊钩<br>Hook block                      |
|  | 副臂安装角<br>Jib offset angle                                      |  | 平衡重<br>Counterweight                  |
|  | 副臂起升高度<br>Hoist height with jib                                |  | 卷扬<br>Winch                           |
|  | 使用第五支腿360°全回转<br>360° operation of the boom with 5th jack down |  | 360°全回转<br>360° operation of the boom |

# 主要技术参数表

## Table of main technical parameters

| 类别<br>Category     | 项目<br>Item   | 单位<br>Unit  | 参数<br>Parameter  |                |
|--------------------|--|-------------|--|----------------|
| 尺寸参数<br>Dimensions | 外形尺寸 (长×宽×高)<br>Dimensions (length×width×height)         | mm          | 14085×2800×3770  |                |
|                    | 轴距 Wheel base  | mm          | 1470+4500+1350   |                |
|                    | 轮距 (前/后) Track (Front/ Rear)                             | mm          | 2316/2063  |                |
|                    | 前悬/后悬 Front/ Rear overhang                               | mm          | 2375/2700  |                |
|                    | 前伸/后伸 Front/ Rear extension                              | mm          | 1690/0   |                |
| 重量参数<br>Weight     | 最大允许总质量<br>Total vehicle mass in travel configuration    |             | kg   | 46000          |
|                    | 轴荷<br>Axle load  | 一轴 1st axle | kg   | 10000          |
|                    |  | 二轴 2nd axle | kg   | 10000          |
|                    |  | 三轴 3rd axle | kg   | 13000          |
|                    |  | 四轴 4rd axle | kg   | 13000          |
| 动力参数<br>Power      | 发动机型号 Engine model                                       | —           | QSL8.9-C360-30   | WD615.334      |
|                    | 额定功率/转速 Rated power/rpm                                  | kW/(r/min)  | 264/2100   | 247/2200       |
|                    | 最大净功率/转速 Max. net power/rpm                              | kW/(r/min)  | —  | 245/2200       |
|                    | 最大输出扭矩/转速<br>Max. output torque/rpm                      | N.m/(r/min) | 1500/1100-1500   | 1350/1100-1600 |
| 行驶参数<br>Travel     | 最高车速 Max. travel speed                                   | km/h        | 48 ( 印度地区 Indian market )<br>/90 ( 非印度地区 other regions ) |                |
|                    | 最低稳定车速 Min. stable travel speed                          | km/h        | 2~3  |                |
|                    | 最小转弯直径 Min. turning diameter                             | m           | ≤24  |                |
|                    | 臂头最小转弯直径<br>Min. turning diameter at boom tip            | m           | ≤29  |                |
|                    | 最小离地间隙<br>Min. ground clearance                          | mm          | 303  |                |
|                    | 接近角 Approach angle                                       | °           | 22   |                |
|                    | 离去角 Departure angle                                      | °           | 13   |                |
|                    | 制动距离 ( 制动初速度为30km/h )<br>Braking distance ( at 30 km/h ) | m           | ≤10  |                |
|                    | 最大爬坡能力<br>Max. grade ability                             | %           | ≥40  |                |
|                    | 百公里油耗<br>Fuel consumption per 100 km                     | L           | 38   |                |
| 噪音<br>Noise        | 加速行驶机外噪声<br>Exterior noise level                         | dB(A)       | ≤84  |                |
|                    | 驾驶员耳旁噪声<br>Noise level at seated position                | dB(A)       | ≤90  |                |

# 主要技术参数表

## Table of main technical parameters

| 类别<br>Category   | 项目<br>Item  |                                      | 单位<br>Unit   | 参数<br>Parameter |     |
|--|---|--------------------------------------|--------------|-----------------|-----|
| 主要性能参数<br>Main performance   | 最大额定总起重量 Max. total rated lifting capacity        |                                      | t            | 80              |     |
|  | 最小额定工作幅度 Min. rated working radius                |                                      | m            | 3               |     |
|  | 转台尾部回转半径<br>Turning radius at turntable tail      | 平衡重处 Counterweight                   | mm           | 4050            |     |
|  |   | 卷扬处 winch                            | mm           | 4190            |     |
|  | 最大起重力矩<br>Max. load moment                        | 基本臂 Base boom                        | kN.m         | 2587            |     |
|  |   | 最长主臂 Fully-extended boom             | kN.m         | 1286            |     |
|  |   | 最长主臂+副臂<br>Fully-extended boom + Jib | kN.m         | 706             |     |
|  | 支腿跨距<br>Outrigger span                            | 纵向 Longitudinal                      | m            | 6.545           |     |
|  |   | 横向 Lateral                           | m            | 7.9             |     |
|  | 起升高度<br>Hoist height                              | 基本臂 Base boom                        | m            | 12.2            |     |
|  |   | 最长主臂 Fully-extended boom             | m            | 46              |     |
|  |   | 最长主臂+副臂<br>Fully-extended boom + Jib | m            | 60.9            |     |
|  | 起重臂长度<br>Boom length                              | 基本臂<br>Base boom                     | m            | 11.83           |     |
|  |   | 最长主臂<br>Fully-extended boom          | m            | 45.5            |     |
| 最长主臂+副臂<br>Fully-extended boom + Jib                                       |   | m                                    | 61.5         |                 |     |
| 副臂安装角 Jib offset angle   |   | °                                    | 0, 15, 30    |                 |     |
| 工作速度参数<br>Working speed  | 起重臂起臂时间 Boom raising time                         |                                      | s            | ≤55             |     |
|  | 起重臂全伸时间 Boom fully extending time                 |                                      | s            | ≤110            |     |
|  | 最大回转速度 Max. slewing speed                         |                                      | r/min        | ≥2              |     |
|  | 支腿收放时间<br>Outrigger extending and retracting time | 水平支腿<br>Outrigger beam               | 收 Retracting | s               | ≤30 |
|  |   |                                      | 放 Extending  | s               | ≤30 |
|  |   | 垂直支腿<br>Outrigger jack               | 收 Retracting | s               | ≤30 |
|  |   |                                      | 放 Extending  | s               | ≤40 |
| 起升速度<br>(单绳,第四层,空载)<br>Hoisting speed<br>(single line, 4th layer, no load) | 主起升机构 Main winch                                  | m/min                                | ≥145         |                 |     |
|  | 副起升机构 Auxiliary winch                             | m/min                                | ≥90          |                 |     |
| 噪声<br>Noise  | 机外辐射 Exterior noise level                         |                                      | dB ( A )     | ≤122            |     |
|  | 司机位置处 Noise level at seated position              |                                      | dB ( A )     | ≤90             |     |



**地址：**江苏省徐州市经济技术开发区高新路68号  
**Add :** No. 68 Gaoxin Road,  
Economic and Technological Development Zone,  
Xuzhou, Jiangsu, China  
**电话(Tel) :** +86-516-83462242/83462350  
**质量监督电话(Quality Inquiry Tel) :** +86-516-  
87888268  
**备件电话(Spare Parts Tel) :** +86-516-83461542  
**邮编(Post Code) :** 221004  
**网址(Web) :** www.xcmg.com/qizhongji

**服务热线 Service Tel**

**400-110-9999**

**400-001-5678**



本印刷品不属于合同。出于产品不断改进的需要，我们保留对产品型号、参数、配置进行变更的权利，恕不另行通知。图片仅供参考，具体产品以实物为准。图片中产品可能并非标准配置，部分部件可能需要另行购置。办理牌照和上路行驶需遵守当地法规。

This print does not belong to the contract. We reserve the right to modify the design (such as product model, parameters and configuration) without notice for improvement. The pictures are just for reference. The product in the picture may not be standard configuration. Some parts need to be purchased separately. Conform to the local laws for license application and road traveling.