

PRODUCT SPECIFICATIONS

# X3 (Gen 2)

The X3 prints strictly engineering-grade plastic parts. It leverages the incredible material qualities of Onyx—twice the strength and stiffness of standard printing plastics—with an advanced sensor suite to deliver unparalleled reliability. Parts meet tight tolerances with beautiful surface finish and are perfect for production line equipment.

<b>Printer Properties</b>	<b>Process</b>	Fused filament fabrication
	<b>Build Volume</b>	330 x 270 x 200 mm (13 x 10.6 x 7.9 in)
	<b>Weight</b>	46 kg (102 lbs)
	<b>Machine Footprint</b>	584 x 483 x 914 mm (23 x 19 x 36 in)
	<b>Print Bed</b>	Kinematic coupling — flat to within 80 µm
	<b>Laser</b>	Bed leveling, active print calibration
	<b>Extrusion System</b>	Second-generation extruder, out-of-plastic detection
	<b>Power</b>	100–240 VAC, 150 W (2 A peak)
	<b>RF Module</b>	Operating Band 2.4 GHz Wi-Fi Standards 802.11 b/g/n
<b>Materials</b>	<b>Plastics Available</b>	Onyx, Onyx FR, Onyx ESD
	<b>Fibers Available</b>	None
	<b>Tensile Strength</b>	52 MPa (1.7x ABS) *
	<b>Tensile Stiffness</b>	4.2 GPa (1.9x ABS) *
<b>Part Properties</b>	<b>Layer Height</b>	100 µm default, 50 µm minimum, 200 µm maximum
	<b>Infill</b>	Closed cell infill: multiple geometries available
<b>Software</b>	<b>Supplied Software</b>	Eiger Cloud (Other options available at cost)
	<b>Security</b>	Two-factor authentication, org admin access, single sign-on

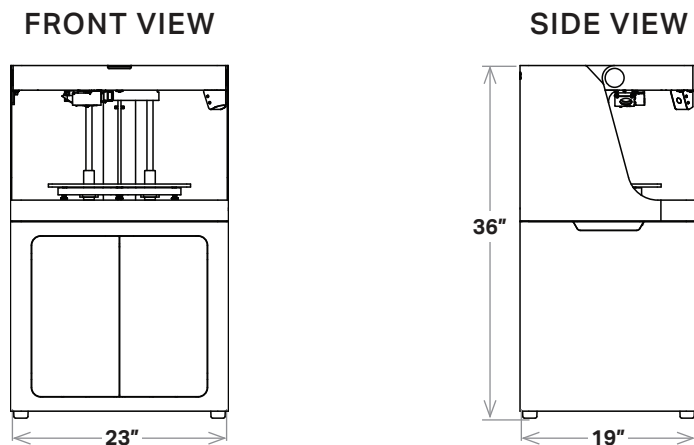

\* Onyx ESD data. **Note:** All specifications are approximate and subject to change without notice.