

GENESIS / **30T**

DETACHABLE OR PERMANENT

The GENESIS 30T is thoughtfully designed to be compact and balanced, making it a superior choice for towing and recovery work in tight areas and where recovery space is limited. Zacklift's innovative reinforced secondary boom gives the Genesis 30T one of the highest extended ratings on the market coming in at 22,000 lbs. The unit's under lift is rated at a very capable 35,000 lbs of lift and 80,000 lbs towing capacity.



GENESIS / 30T

DETACHABLE OR PERMANENT

**THE WORLD LEADER IN HEAVY DUTY
DETACHABLE TOWING.**



The Zacklift GENESIS 30T is a fifth-wheel, detachable, 30 TON integrated boom and under lift system. Finally, a tow system that gives the user superior flexibility with zero compromises made on capability and quality. The innovative GENESIS 30T system gives the user the ability to "Build-A-Fifthwheeler"™ exactly as they need without the expense and limitations that come with standard heavy duty tow trucks.

The GENESIS 30T is thoughtfully designed to be compact and balanced, making it a superior choice for towing and recovery work in tight areas and where recovery space is limited. Zacklift's innovative reinforced secondary boom gives the Genesis 30T one of the highest extended ratings on the market coming in at 22,000 lbs. The unit's under lift is rated at a very capable 35,000 lbs of lift and 80,000 lbs towing capacity. The GENESIS 30T ships ready to work with minimal installation required. The signature durability Zacklift is known for has been engineered into the Genesis and will hold up to strenuous demands required by today's heavy duty towing professional. The flexibility and industry leading price point of the GENESIS makes it a solid investment in today's aggressive and unpredictable towing industry. The GENESIS 30T drops in place on recommended wheelbase tractors with no major modification or welding required. The GENESIS 30T is easily loaded or unloaded and stows easily off the tractor when needed. Permanent units are also available.

Optional accessories include a range of modular tool boxes, winches, fenders, wireless remote and pintle/ball/fifthwheel hitch. The GENESIS 30T is a truly customizable and upgradeable heavy duty towing system.

* SHOWN WITH OPTIONAL EXTRA TOOL BOXES AND FENDERS.



GENESIS 30T

DETACHABLE OR PERMANENT

PART #/ G-30T-WP/G-30T-VIPP

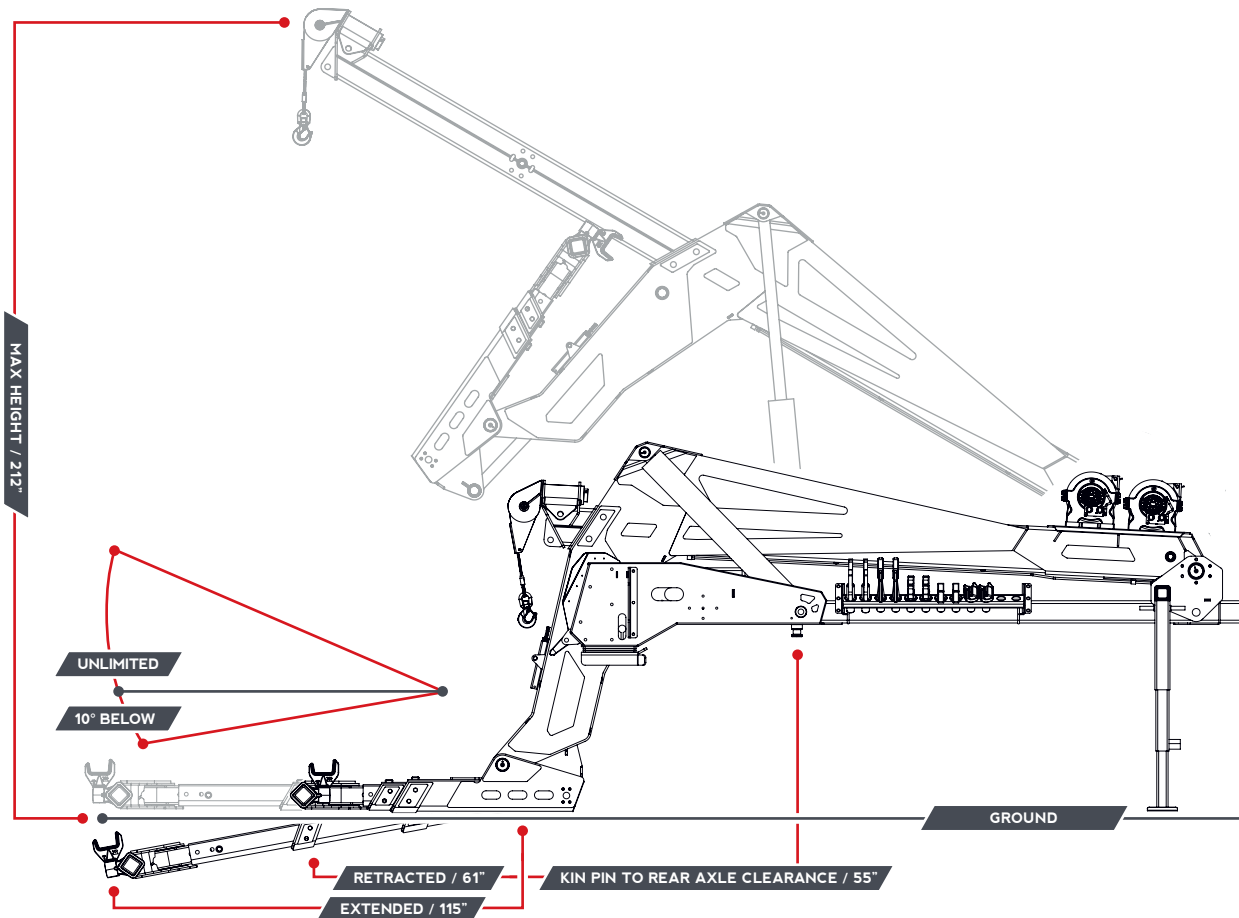

STANDARD / OPTIONAL

GENESIS 30T STANDARD EQUIPMENT Wrecker & VIP Packages:

- Aerodyne Toolboxes
- 38k Stifflegs w/ 18" Flip Feet (Bolt On)
- 2ea 30k Hydraulic Winch w/ 200' 5/8" Wire Rope
- 12 Button Wireless Remote
- Fork Rack
- 1" x 2.5" Fork (Pair)
- Torsion Bar Fork (Pair)
- 6" x 6.5" Fork (Pair)
- 9" x 4" Fork (Pair)
- Chain Fork slotted for 1/2" to 5/8" Chain (Pair)
- Chain Blocks (Pair)
- Universal Fork Receiver (Pair)
- 12" Reach Extender (Pair)
- 2ea Safety Chains & Storage
- Breakaway Cable Tie-Back (Patent Pending)
- 36" LED wireless light bar
- EZ Hook Up (QD for Hydraulic Power & Glad Hands for Air)
- Quick Disconnect for Air Brakes & Air Tools
- Stop, Turn and Tail Lights

GENESIS 30T OPTIONS

- Saddle Bag Toolbox w/ Roll Up Door & Adjustable Shelves
- Zacklift Aerodyne Toolboxes
- Warn 20k or 30k Hydraulic Winch w/ 200' 1/2" Wire Rope
- Custom Aluminum Round or Straight Style Fenders
- Fifthwheel Hitch with 20k Pintel & 2-5/16" Ball Combination
- Zacklift Aluminum Light Pylon
- LED Work Lights
- Heavy Duty Wheel Lift
- Specialty Forks
- Custom Graphic Toolbox Wrap
- Custom Paint

* Minor Assembly Required



UNDERLIFT CAPACITY SPECIFICATIONS

UNDERLIFT CAPACITY - RETRACTED / 35,000 LBS

UNDERLIFT CAPACITY - EXTENDED / 16,000 LBS

UNDERLIFT MAX TOW CAPACITY / 85,000 LBS

UNDERLIFT TILT BELOW GROUND / 10 DEG

UNDERLIFT REACH RETRACTED / 61 IN

UNDERLIFT REACH EXTENDED / 115 IN

UNDERLIFT MAX REACH W/ 12" EXTENSION / 131 IN

BASE UNIT WEIGHT / 13,000 LBS

BOOM CAPACITY SPECIFICATIONS

BOOM (RETRACTED @ 30 DEG) / 60,000 LBS

BOOM MAX HOOK HEIGHT / 194"

BOOM (EXTENDED @ 30 DEG) / 22,000 LBS

BOOM HYDRAULIC EXTENTION / 96 IN

AVAILABLE GENESIS PACKAGE OPTION DETAILS BELOW

WRECKER PACKAGE:

G-30T-WP

FEATURES: DETACHABLE 30 TON INTEGRATED BOOM WITH 8' HYDRAULIC EXTENSION AND 35,000 LB UNDERLIFT WITH 85,000 TOWING CAPACITY

PACKAGE INCLUDES:

PACKAGE INCLUDES:

- 1EA - BASE UNIT GENESIS 30T BOOM, STIFFLEGS, AND UNDERLIFT (P/N ZA000045-A)
- 2EA - AERODYNE TOOLBOX 72" X 16" X 28.5" DEEP (P/N TB-72X16)
- 2EA - 30K WARN WINCH: INCLUDES 5/8" X 200' WIRE ROPE AND 7 TON HOOK (P/N WRN-3000)
- 1EA - 36" WIRELESS SAFETY LIGHT BAR
- 1EA - 12 BUTTON WIRELESS REMOTE
- 5EA - STANDARD FRAME FORK SETS WITH FORK RACK
- 1EA - CABLE TIE-BACK SYSTEM (PATENT PENDING)
- 1EA - EZLOAD STAND
- 2EA - SAFETY CHAIN (1/2" GR70 CHAIN 12' LONG)
- PAINTED ZACKLIFT RED OR BLACK UNLESS OTHERWISE QUOTED

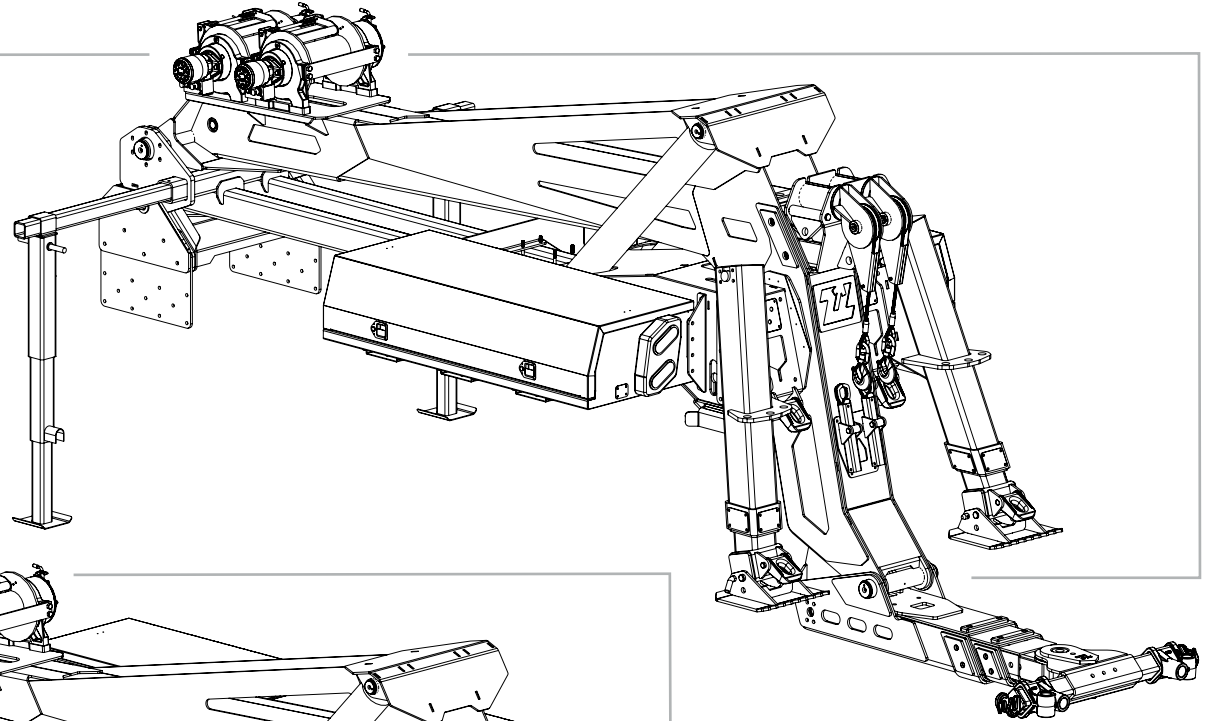

VIP PACKAGE:

G-30T-VIPP

FEATURES: DETACHABLE 30 TON INTEGRATED BOOM WITH 8' HYDRAULIC EXTENSION AND 35,000 LB UNDERLIFT WITH 85,000 TOWING CAPACITY

PACKAGE INCLUDES:

PACKAGE INCLUDES:

- 1EA - BASE UNIT GENESIS 30T BOOM, STIFFLEGS, AND UNDERLIFT (P/N ZA000045-A)
- 2EA - AERODYNE TOOLBOX 72" X 24" X 28.5" DEEP (P/N TB-72X24-AERO)
- 2EA - AERODYNE TOOLBOX 60" X 24" X 28.5" DEEP (P/N TB-60X24-AERO)
- 2EA - MILITARY STYLE FENDER WITH MUD FLAP (P/N FB-1000-M-EXT)
- 2EA - 30K WARN WINCH: INCLUDES 5/8" X 200' WIRE ROPE AND 7 TON HOOK (P/N WRN-3000)
- 1EA - 36" WIRELESS SAFETY LIGHT BAR
- 1EA - 12 BUTTON WIRELESS REMOTE
- 5EA - STANDARD FRAME FORK SETS WITH FORK RACK
- 1EA - CABLE TIE-BACK SYSTEM (PATENT PENDING)
- 1EA - EZLOAD STAND
- 2EA - SAFETY CHAIN (1/2" GR70 CHAIN 12' LONG)
- PAINTED ZACKLIFT RED OR BLACK UNLESS OTHERWISE QUOTED

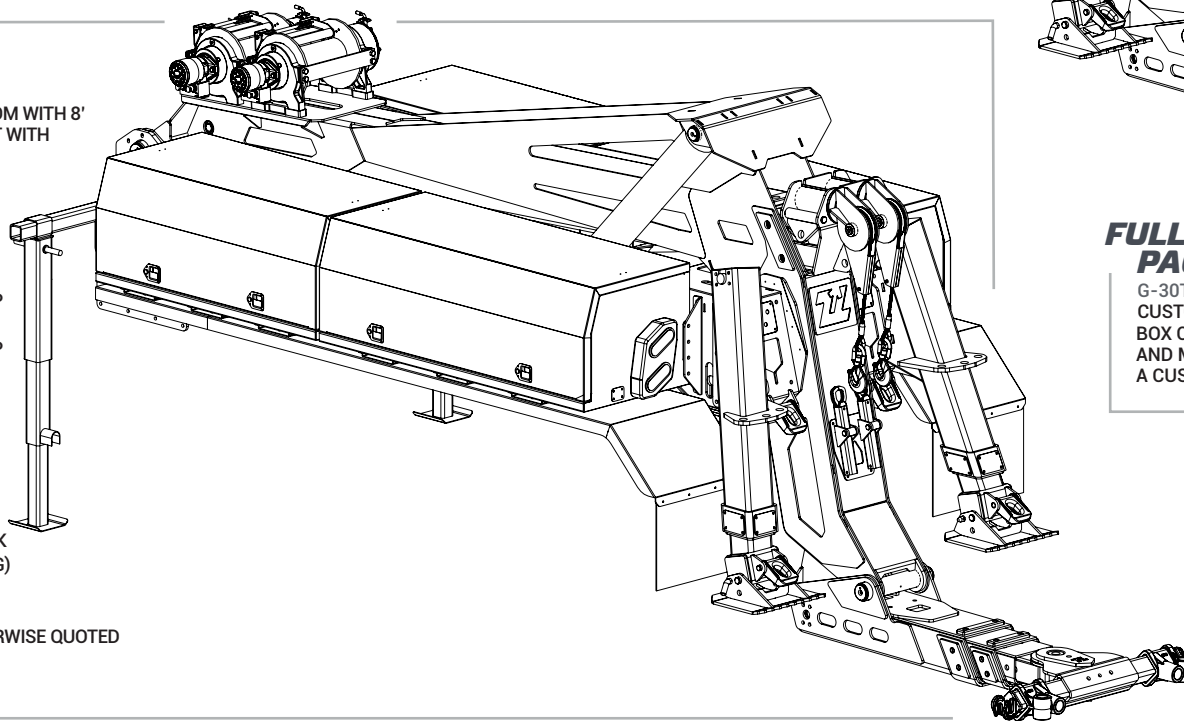

FULL CUSTOM PACKAGE:

G-30T-WP

CUSTOM PAINT COLORS, CUSTOM TOOL BOX CONFIGURATIONS, GRAPHIC WRAPS, AND MORE. CONTACT SALES TODAY FOR A CUSTOM BUILD SHEET AND MORE INFO

