

FIFTHWHEELER / Z252 Z353 Z453

CHASSIS RECOMMENDATIONS

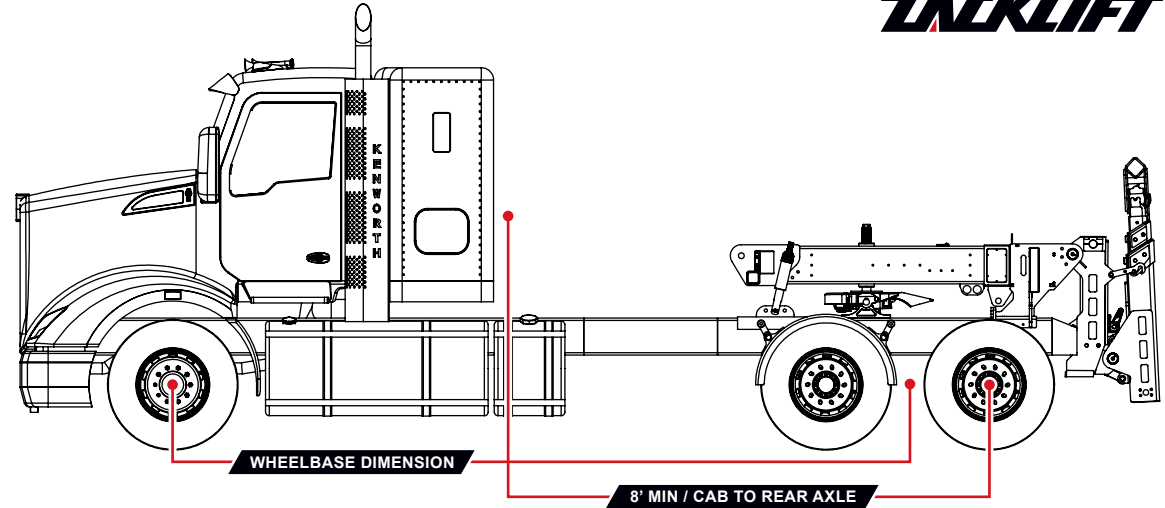

MINIMUM WHEELBASE RECOMMENDATIONS

NOTE: COUNTER WEIGHT MAYBE REQUIRED FOR SHORTER WHEELBASES

| MODEL | IMPERIAL | METRIC |
|-------|----------------|----------------|
| Z252 | 240" + | 6096 MM + |
| Z353 | 280 - 300" | 7112 - 7620 MM |
| Z453 | 300 - 320 MM + | 8128 MM+ |

HYDRAULIC REQUIREMENTS FOR PTO / PUMP (Z1304-52NC)

| CONFIGURATION | IMPERIAL FLOW RATE / PRESSURE | | METRIC FLOW RATE / PRESSURE | |
|------------------------------|-------------------------------|-----------------|-----------------------------|-------------|
| ZACKLIFT ONLY | 6-10 GPM | 2,500-3,000 PSI | 23-38 LPM | 172-207 BAR |
| ZACKLIFT / STIFFLEGS & WINCH | 10-12 GPM | 2,500-3,000 PSI | 38-45 LPM | 172-207 BAR |

ZACKLIFT CRATED SHIPPING WEIGHTS

| MODEL | FIFTHWHEELER | | PERMANENT MOUNT | |
|-------|--------------|---------|-----------------|---------|
| Z252 | 4,220 LBS | 1914 KG | 1,875 LBS | 850 KG |
| Z353 | 5,115 LBS | 2320 KG | 2,770 LBS | 1256 KG |
| Z453 | 5,805 LBS | 2633 KG | 3,460 LBS | 1569 KG |

GENERAL NOTES

- 12V SELF CONTAINED POWER PACK (Z1304 - 59NC) / CAN ONLY OPERATE ZACKLIFT UNIT, NO ACCESSORIES I.E. WINCH & IS NOT RECOMMENDED FOR Z353 OR Z453, SLOW MOVEMENT & OVERHEATING MAY OCCUR
- TRAILER GLAD HANDS FOR EMERGENCY AND SERVICE AIR
- TRAILER 7 WAY PLUG (TAIL LIGHTS AND 12V ACCESSORIES POWER)
- FIFTHWHEEL PLATE ON TRUCK MUST BE ADJUSTABLE
- TYPICAL CHASSIS FRAME WIDTH (OUTSIDE OF RAIL) IS 32" TO 35" OR (812 MM TO 889 MM)