



# Platform II 43", 49", 55", 65"

Specification Sheet



PLATFORM II SPEC SHEET v3.1 / U.S. Patent No. 10225509 / EFFECTIVE 4/10/2024  
*Specifications are subject to change without notice.*

The Platform II is the flagship line of ruggedized multitouch tables from Ideum, available with 43", 49", 55", and 65" displays. It includes a 4K Ultra HD LG commercial display rated 24/7 and industry-leading touch technology from TES (formerly 3M™) with support for 80 simultaneous touch points. The Platform II can support tangible interaction.



The Platform II comes complete with a full-featured and powerful integrated 14th Gen Intel® Core™ processor, the latest NVIDIA™ discrete graphics card, and single push-button power. The Platform II touch table comes standard with Windows 11 Pro and can run any supported PC applications. The Platform II can also be purchased with an AOPEN Commercial Chromebox 2 rated for 24/7 use.

# Platform II

## Specification Sheet

The thin profile computer case inside the pedestal base allows for a full-sized graphics card, and the enclosure makes the unit incredibly quiet. The all-aluminum construction and additional fans provide additional active cooling in a modular design. *(The photo below shows the internal components.)*

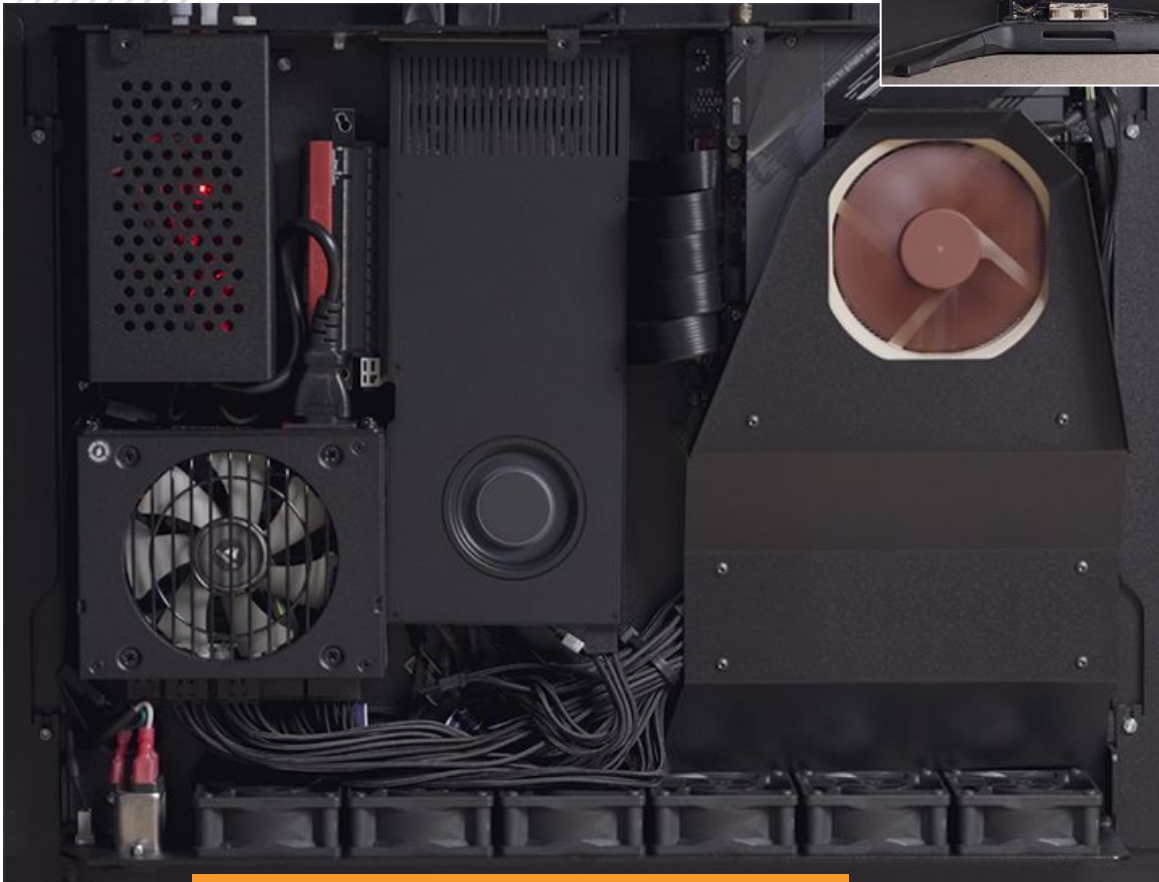
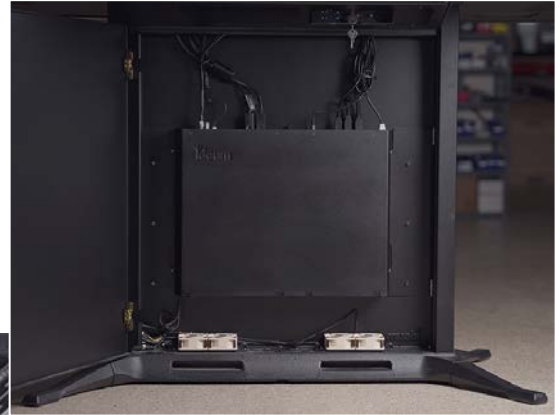

Ideum displays use a patented manufacturing method.

The Platform II is built in the USA and ships as a complete turnkey system with lockable, push-button operation. It doesn't require a technician or any special installation setup—just plug it in and turn it on. All of Ideum's hardware is backed by a three-year warranty.

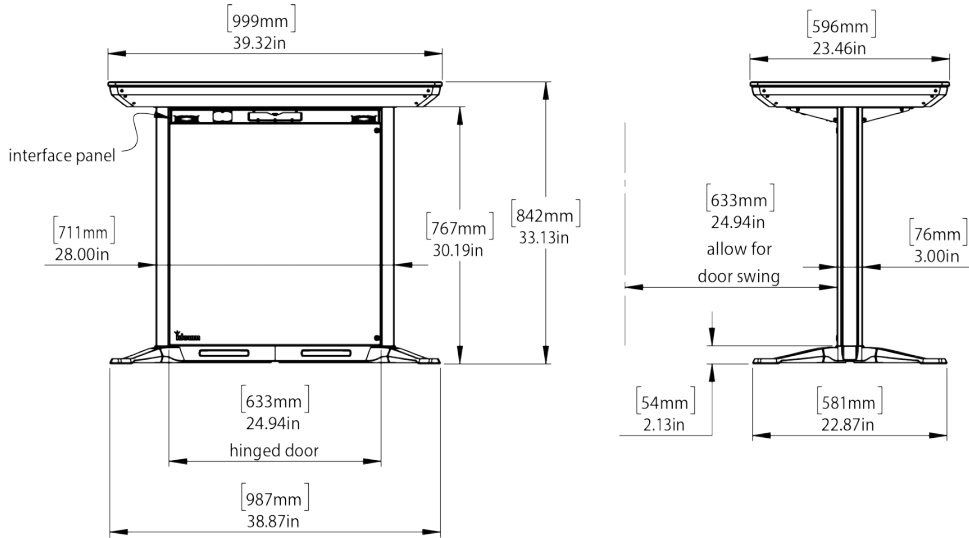

<b>WEIGHT</b> <b>140 LBS</b> <b>64 KG*</b>
<b>SHIP WEIGHT</b> <b>270 LBS</b> <b>122 KG*</b>
<b>WITH TRAVEL CASE</b> <b>370 LBS</b> <b>168 KG*</b>

\*Weights may vary slightly.

## Interactive Display

- › 4K UHD (3840x2160) LG commercial display rated 24/7
- › 43" diagonal, strengthened, anti-stiction, 4mm glass surface
- › TES (formerly 3M™) projected capacitive touch sensor
- › ±5 ms touch response time
- › 80 touch points with palm rejection
- › Native contrast ratio 1100:1
- › 400 nit (cd/m2) luminance

## Integrated System

<ul style="list-style-type: none"> <li>› Single push-button power</li> <li>› Custom lockable enclosure</li> <li>› Windows 11 Pro</li> <li>› Universal 110-240V power system</li> <li>› 4 amps or 400W at max load, approximately 1 amp at idle</li> <li>› Two 10W integrated speakers</li> </ul>	<p><b>STANDARD</b></p> <ul style="list-style-type: none"> <li>› Intel 14th Gen Core i5-14600K processor</li> <li>› NVIDIA RTX A2000 6GB graphics card</li> <li>› 16GB DDR5 RAM</li> <li>› 250GB M.2 NVMe SSD</li> </ul>	<p><b>PERFORMANCE</b></p> <ul style="list-style-type: none"> <li>› Intel 14th Gen Core i7-14700K processor</li> <li>› NVIDIA RTX 4000 16GB Ada Generation graphics card</li> <li>› 32GB DDR5 RAM</li> <li>› Dual 250GB M.2 NVMe SSD</li> </ul>
--	---	--

## Connectivity

- › TPM/TPP compatible for secure environments
- › WiFi 802.11 a/b/g/n/ac, Ethernet, Bluetooth 5.0
- › Wireless keyboard with integrated trackpad
- › Direct access via USB ports
- › Audio output via 1/8" audio jack
- › HDMI output (PC)
- › RFID (optional)
- › Communication hardware can be removed upon request for secure environments



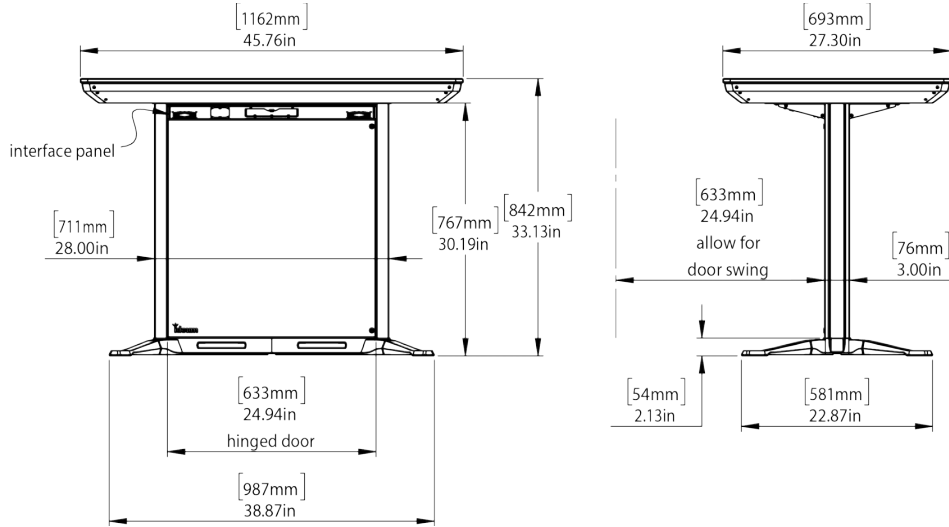

**WEIGHT**  
150 LBS  
68 KG\*

**SHIP WEIGHT**  
310 LBS  
141 KG\*

**WITH TRAVEL CASE**  
375 LBS  
170 KG\*

*\*Weights may vary slightly.*

## Interactive Display

- › 4K UHD (3840x2160) LG commercial display rated 24/7
- › 49" diagonal, strengthened, anti-stiction, 4mm glass surface
- › TES (formerly 3M™) projected capacitive touch sensor
- › ±5 ms touch response time
- › 80 touch points with palm rejection
- › Native contrast ratio 1100:1
- › 500 nit (cd/m2) luminance

## Integrated System

- |  |   |  |
|--|---|--|
| <ul style="list-style-type: none"> <li>› Single push-button power</li> <li>› Custom lockable enclosure</li> <li>› Windows 11 Pro</li> <li>› Universal 110-240V power system</li> <li>› 4 amps or 400W at max load, approximately 1 amp at idle</li> <li>› Two 10W integrated speakers</li> </ul> | <p><b>STANDARD</b></p> <ul style="list-style-type: none"> <li>› Intel 14th Gen Core i5-14600K processor</li> <li>› NVIDIA RTX A2000 6GB graphics card</li> <li>› 16GB DDR5 RAM</li> <li>› 250GB M.2 NVMe SSD</li> </ul> | <p><b>PERFORMANCE</b></p> <ul style="list-style-type: none"> <li>› Intel 14th Gen Core i7-14700K processor</li> <li>› NVIDIA RTX 4000 16GB Ada Generation graphics card</li> <li>› 32GB DDR5 RAM</li> <li>› Dual 250GB M.2 NVMe SSD</li> </ul> |
|--|---|--|

## Connectivity

- › TPM/TPP compatible for secure environments
- › WiFi 802.11 a/b/g/n/ac, Ethernet, Bluetooth 5.0
- › Wireless keyboard with integrated trackpad
- › Direct access via USB ports
- › Audio output via 1/8" audio jack
- › HDMI output (PC)
- › RFID (optional)
- › Communication hardware can be removed upon request for secure environments

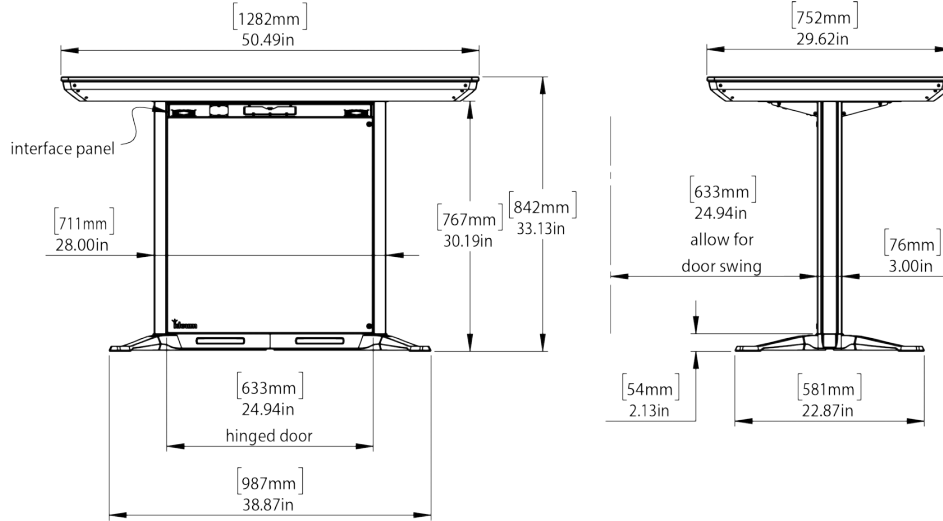

**WEIGHT**  
165 LBS  
75 KG\*

**SHIP WEIGHT**  
335 LBS  
152 KG\*

**WITH TRAVEL CASE**  
395 LBS  
179 KG\*

*\*Weights may vary slightly.*

### Interactive Display

- › 4K UHD (3840x2160) LG commercial display rated 24/7
- › 55" diagonal, strengthened, anti-stiction, 4mm glass surface
- › TES (formerly 3M™) projected capacitive touch sensor
- › ±5 ms touch response time
- › 80 touch points with palm rejection
- › Native contrast ratio 1100:1
- › 500 nit (cd/m2) luminance

### Integrated System

- |  |   |  |
|--|---|--|
| <ul style="list-style-type: none"> <li>› Single push-button power</li> <li>› Custom lockable enclosure</li> <li>› Windows 11 Pro</li> <li>› Universal 110-240V power system</li> <li>› 4 amps or 400W at max load, approximately 1 amp at idle</li> <li>› Two 10W integrated speakers</li> </ul> | <p><b>STANDARD</b></p> <ul style="list-style-type: none"> <li>› Intel 14th Gen Core i5-14600K processor</li> <li>› NVIDIA RTX A2000 6GB graphics card</li> <li>› 16GB DDR5 RAM</li> <li>› 250GB M.2 NVMe SSD</li> </ul> | <p><b>PERFORMANCE</b></p> <ul style="list-style-type: none"> <li>› Intel 14th Gen Core i7-14700K processor</li> <li>› NVIDIA RTX 4000 16GB Ada Generation graphics card</li> <li>› 32GB DDR5 RAM</li> <li>› Dual 250GB M.2 NVMe SSD</li> </ul> |
|--|---|--|

### Connectivity

- › TPM/TPP compatible for secure environments
- › WiFi 802.11 a/b/g/n/ac, Ethernet, Bluetooth 5.0
- › Wireless keyboard with integrated trackpad
- › Direct access via USB ports
- › Audio output via 1/8" audio jack
- › HDMI output (PC)
- › RFID (optional)
- › Communication hardware can be removed upon request for secure environments

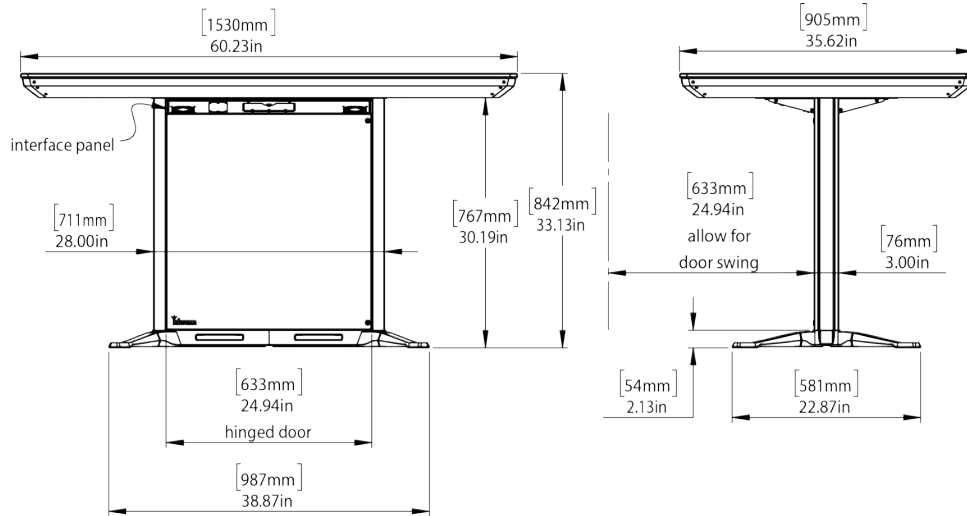

<b>WEIGHT</b> 200 LBS 91 KG*
<b>SHIP WEIGHT</b> 375 LBS 170 KG*
<b>WITH TRAVEL CASE</b> 480 LBS 218 KG*

\*Weights may vary slightly.

## Interactive Display

- › 4K UHD (3840x2160) LG commercial display rated 24/7
- › 65" diagonal, strengthened, anti-stiction, 4mm glass surface
- › TES (formerly 3M™) projected capacitive touch sensor
- › ±5 ms touch response time
- › 80 touch points with palm rejection
- › Native contrast ratio 1100:1
- › 500 nit (cd/m2) luminance

## Integrated System

- |  |   |  |
|--|---|--|
| <ul style="list-style-type: none"> <li>› Single push-button power</li> <li>› Custom lockable enclosure</li> <li>› Windows 11 Pro</li> <li>› Universal 110-240V power system</li> <li>› 4 amps or 400W at max load, approximately 1 amp at idle</li> <li>› Two 10W integrated speakers</li> </ul> | <p><b>STANDARD</b></p> <ul style="list-style-type: none"> <li>› Intel 14th Gen Core i5-14600K processor</li> <li>› NVIDIA RTX A2000 6GB graphics card</li> <li>› 16GB DDR5 RAM</li> <li>› 250GB M.2 NVMe SSD</li> </ul> | <p><b>PERFORMANCE</b></p> <ul style="list-style-type: none"> <li>› Intel 14th Gen Core i7-14700K processor</li> <li>› NVIDIA RTX 4000 16GB Ada Generation graphics card</li> <li>› 32GB DDR5 RAM</li> <li>› Dual 250GB M.2 NVMe SSD</li> </ul> |
|--|---|--|

## Connectivity

- › TPM/TPP compatible for secure environments
- › WiFi 802.11 a/b/g/n/ac, Ethernet, Bluetooth 5.0
- › Wireless keyboard with integrated trackpad
- › Direct access via USB ports
- › Audio output via 1/8" audio jack
- › HDMI output (PC)
- › RFID (optional)
- › Communication hardware can be removed upon request for secure environments

## Customizations



### Built-In Casters

Low profile built-in casters make it easy to move the Platform II.



### Colors and Finishes

Available in hundreds of RAL color and finish options. (1-2 weeks additional lead time.)



### ATA Flight Case

Reusable travel case with locking casters and locking latch clasps.



### Chromebox System

Replaces the PC with an AOPEN Chromebox Commercial 2 rated 24/7.



### What's Inside

Our touch tables and touch walls include the best performing, most reliable components available.

4K UHD (3840x2160) commercial LCD display



PCAP touch sensor with 80 touch points TES (3M) technology



NVIDIA™ graphics card



14th Gen Intel® Core™ Processor



Aircraft-grade aluminum made in the USA



## Software



The Platform II touch table comes with Windows 11 Pro and supports PC applications. Applications that are optimized for touch work best.

Ideum offers custom software development. We have experience developing interactive applications mostly for public spaces. Our expertise in a broad range of programming environments allows our work to span the realms of informal and formal education, interactive technology, art, and entertainment.

### ALSO AVAILABLE



#### Tangible Authoring

**Ideum multitouch tables support the Tangible Engine object recognition SDK.**

Tangible Engine 2 is an authoring environment supporting the use of fiducial object recognition on Ideum multitouch tables. This software allows for the unique recognition of objects with 3D printed conductive patterns. Tangible Engine 2 includes test objects, a Visualizer / Configurator Tool, an SDK, and documentation.

Pricing and more information can be found at: [tangibleengine.com](https://tangibleengine.com)



#### RFID Utility

**Ideum multitouch products include an optional RFID utility for enhanced functionality.**

Our new and improved RFID software allows you to automate system tasks, launch and switch applications, and more with a single movement. This useful utility is free for Ideum touch table owners.

Learn more at: [ideum.com/news/rfid-reader-app](https://ideum.com/news/rfid-reader-app)



# Platform II

Specification Sheet

## About Ideum

Ideum designs experiences for public spaces, offering exhibit design, AV, and software development services to museums, nonprofits, and socially responsible companies. We are proudly based in Corrales, New Mexico, and collaborate with creative partners worldwide.

### SALES & DESIGN INQUIRIES

We sell our multitouch tables and displays directly, both in the USA and internationally. Ask us how to turn your interactive goals into amazing reality.

Use our [online inquiry form](#)  
Email: [sales@ideum.com](mailto:sales@ideum.com)  
Phone: (505) 792-1110 ext. 1

### WARRANTY & SUPPORT

Our products are custom-built with only the highest quality components available and are designed to last. We back all of our hardware, including custom exhibits, with a three-year warranty. The same people who design and build our systems provide our timely support.

Submit a ticket: [support.ideum.com](https://support.ideum.com)  
Email: [support@ideum.com](mailto:support@ideum.com)  
Phone: (505) 792-1110 ext. 2

**Hours: 8:00 AM – 5:00 PM Mountain Time, Monday through Friday.**

The Colossus, Drafting, Pano, Platform, Pico, Pro, Reader Rail, and Inline touch tables and the Portrait and Presenter touch displays from Ideum are designed, manufactured, and made in the USA of U.S. and imported parts.



Compliant with height and reach requirements for the Americans with Disabilities Act standards for accessibility. Learn more about Ideum's commitment to accessibility at [www.ideum.com/ada](http://www.ideum.com/ada)

*IMPORTANT NOTICE TO PURCHASER: Specifications are subject to change without notice. Ideum hardware and software are warranted from the date of receipt to the period stated in the warranty. Please note that under Ideum's warranty, Ideum has no obligation for any hardware product that is modified or damaged through misuse, accident, neglect, or subsequent integration, service, or tampering, by anyone other than Ideum or an Ideum-approved entity or individual. Ideum makes no additional warranties, express or implied, including but not limited to any fitness for a particular purpose. The User is responsible for determining whether Ideum hardware products or software are fit for the User's particular purpose. If the hardware product or software are proven not to have met Ideum's warranty, then Ideum's sole obligation and User's and Purchaser's exclusive remedy will be, at Ideum's option, to repair or replace the product or refund its purchase price. Ideum shall not be liable in any action against it in any way related to the hardware products or software for any loss or damages, whether non-specified, direct, indirect, special, incidental or consequential (including downtime, loss of profits or goodwill) regardless of the legal theory asserted. Please see our full warranty for complete details.*

