

TRINITRON® COLOR VIDEO MONITOR

PVM-2030

PVM-2530

OPERATING INSTRUCTIONS page 2

Before operating the unit, please read this manual thoroughly and retain it for future reference.

MODE D'EMPLOI page 20

Avant la mise en service de cet appareil, prière de lire attentivement ce mode d'emploi que l'on conservera pour toute référence ultérieure.

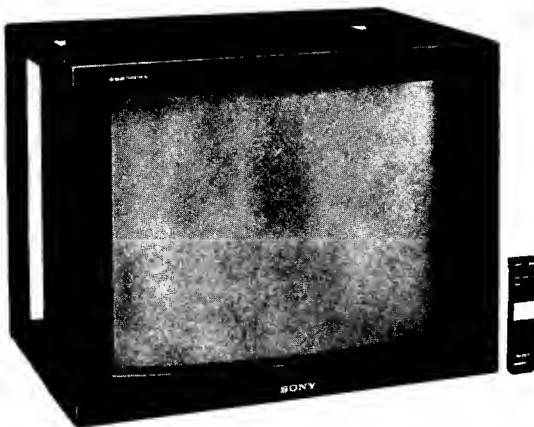

The PVM-2030/2530 comes in 2 different colors; all black and, to match the U-matic VTRs, black and white.

Le PVM-2030/2530 se présente en deux couleurs: soit tout noir, soit, pour convenir aux magnétoscopes U-matic, en noir et blanc.

OWNER'S RECORD

The model and serial numbers are located on the rear.
Record the serial number in the space provided below. Refer to these numbers whenever you call upon your Sony dealer regarding this product.

Model No. _____ Serial No. _____

WARNING

To prevent fire or shock hazard, do not expose the unit to rain or moisture.

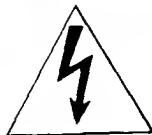
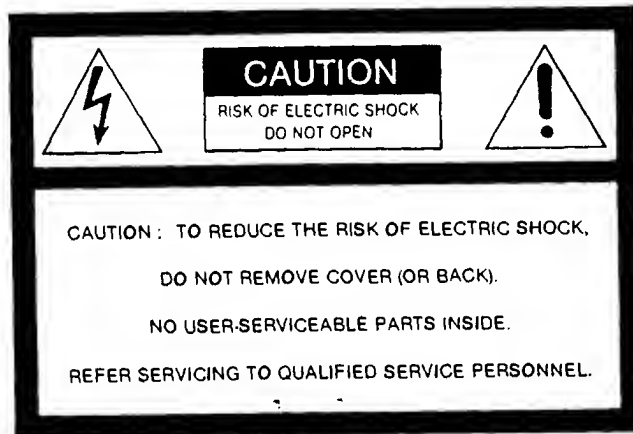

This symbol is intended to alert the user to the presence of uninsulated "dangerous voltage" within the product's enclosure that may be of sufficient magnitude to constitute a risk of electric shock to persons.



This symbol is intended to alert the user to the presence of important operating and maintenance (servicing) instructions in the literature accompanying the appliance.

FOR THE CUSTOMERS IN THE USA

INFORMATION

This equipment generates and uses radio frequency energy and if not installed and used properly, that is, in strict accordance with the manufacturer's instructions, may cause interference to radio and television reception. It has been type tested and found to comply with the limits for a Class B computing device in accordance with the specifications in Subpart J of Part 15 of FCC Rules, which are designed to provide reasonable protection against such interference in a residential installation. However, there is no guarantee that interference will not occur in a particular installation. If this equipment does cause interference to radio or television reception, which can be determined by turning the equipment off and on, the user is encouraged to try to correct the interference by one or more of the following measures:

Reorient the receiving antenna

Relocate the equipment with respect to the receiver

Move the equipment away from the receiver

Plug the equipment into a different outlet so that equipment and receiver are on different branch circuits.

If necessary, the user should consult the dealer or an experienced radio/television technician for additional suggestions. The user may find the following booklet prepared by the Federal Communications Commission helpful:

"How to Identify and Resolve Radio-TV Interference Problems".

This booklet is available from the U.S. Government Printing Office, Washington, DC 20402, Stock No. 004-000-00345-4.

For the customers in Canada

This apparatus complies with the Class B limits for radio noise emissions set out in Radio Interference Regulations.

This manual covers the following two models:

PVM-2030: 20 inch picture tube

PVM-2530: 25 inch picture tube

The function and the appearance are the same. Any difference will be clearly described in this manual.

TABLE OF CONTENTS

| | |
|---|----|
| Outline..... | 3 |
| Precautions | 3 |
| Location and function of parts and controls | 4 |
| System connections | 10 |
| Connecting a VTR..... | 10 |
| Connecting a video camera | 11 |
| Connecting several monitors | 12 |
| Connecting a microcomputer | 15 |
| Specifications | 16 |
| Troubleshooting | 18 |

OUTLINE

High-resolution picture

The Fine Pitch Trinitron picture tube, whose aperture grill pitch is 0.55 mm (PVM-2030) or 0.73 mm (PVM-2530), gives a high resolution (composite: 560 TV lines, RGB: 2000 characters) picture.

Analog/digital RGB input

Analog RGB and digital RGB input signals can be fed to the RGB input connector (25-pin multi connector), which allow a microcomputer to be connected to this monitor.

New Dynamic Color™

If the color temperature is set to obtain "bluish white", the skin tone becomes unnatural. New Dynamic Color™ allows bluish white and natural skin tone to be obtained by controlling the amplitude of the RGB signals.

Colorpure filter™

Fine picture detail without color spill or color noise is obtained through the comb filter. The notches which form along the horizontal contour can be eliminated through a combination of the comb and other filters.

S VIDEO connector

The video signal from a VTR is composed of the chrominance (C) signal and the luminance signal (Y). In a composite video signal, these two signals are combined, which reduces the video quality because the combined signals tend to interfere with each other. However, when input to the S VIDEO connector instead of the BNC connectors or VTR connector, the composite video signal is split into its component signals, thus eliminating the problem of interference and assuring the video quality.

Powerful sound

The powerful hi-fi sound (15 W + 15 W /8 ohms) is obtained through the 2-way speakers (optional).

Touch panel control

When adjustment is needed, an orange indicator on the touch panel controller lights up.

Control S

The CONTROL S signal allows remote control of several monitors and a VTR through a single monitor.

PRECAUTIONS

On safety

- Check that the operating voltage of your unit is identical with the voltage of your local power supply.
- Should any liquid or solid object fall into the cabinet, unplug the unit and have it checked by qualified personnel before operating it any further.
- Unplug the unit from the wall outlet if it is not to be used for several days or more.
- To disconnect the AC power cord, pull it out by the plug. Never pull the cord itself.

On installation

- Allow adequate air circulation to prevent internal heat build-up.
Do not place the unit on surfaces (rugs, blankets, etc.) or near materials (curtains, draperies) that may block the ventilation holes.
- Do not install the unit in a location near heat sources such as radiators or air ducts, or in a place subject to direct sunlight, excessive dust, mechanical vibration or shock.

On cleaning

To keep the unit looking brand-new, periodically clean it with a soft cloth. Stubborn stains may be removed with a cloth lightly dampened with a mild detergent solution. Never use strong solvents such as thinner or benzine, or abrasive cleansers since these will damage the cabinet. As a safety precaution, unplug the unit before cleaning it.

On repacking

Do not throw away the carton and packing materials. They make an ideal container in which to transport the unit. When shipping the unit to another location, repack it as illustrated on the carton.

If you have any questions about this unit, contact your authorized Sony dealer.

LOCATION AND FUNCTION OF PARTS AND CONTROLS

Front panel

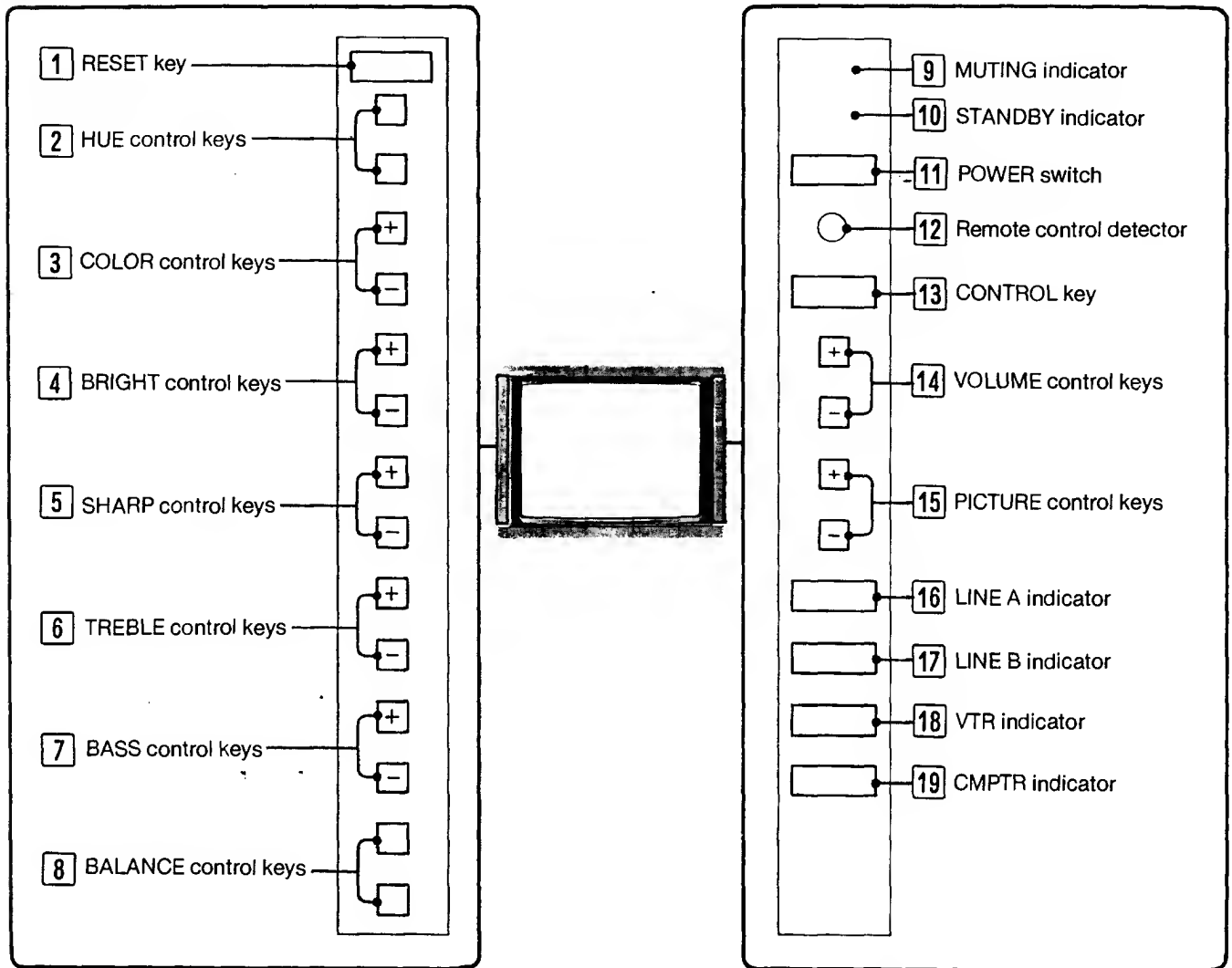

- Press CONTROL key after power is turned on to light the control keys or indicators.

The following control keys are effective only when MANUAL CONTROL switch on the rear panel is set to ON.

- | | |
|---|--|
| <p>1 RESET key Press this key to return to the standard setting. • This key is effective only for the control keys on the left.</p> <p>2 HUE control keys Press the GRN (green) key to make the skin tones greenish or the PUR (purple) key to make it purplish.</p> <p>3 COLOR control keys Press the + key to make the color intensity vivid or the - key to make it pale.</p> <p>4 BRIGHT (brightness) control keys Press the + key to make the picture brighter or the - key to make it darker.</p> | <p>5 SHARP (sharpness) control keys Press the + key to obtain a sharp picture or the - key to obtain a less sharp picture.</p> <p>6 TREBLE control keys Press the + key to increase the treble (high tone) or the - key to decrease it.</p> <p>7 BASS control keys Press the + key to increase the bass (low tone) or the - key to decrease it.</p> <p>8 BALANCE control keys Press the L key to increase the sound volume of the left speaker or the R key to increase the sound volume of the right speaker.</p> |
|---|--|

9 MUTING indicator

Illuminates while the sound is muted.

- Muting is controlled only by a remote commander.

10 STAND BY indicator

Illuminates when the POWER switch is turned off.

11 POWER switch

Press this switch to turn the monitor on.

Press this switch again to turn it off.

- When the monitor is turned on, the settings of the monitor are the same as when it was last turned off.
- For a few seconds after turning on the monitor the color of picture may vary because the white balance is adjusted at this time. This is not a problem.

12 REMOTE control detector

The beam from the Remote Commander is received here.

13 CONTROL key

Press this key to illuminate the keys and indicators on the front panel.

Press this key again to extinguish them.

14 VOLUME control keys

Press the + key to raise the volume or the – key to lower it.

15 PICTURE control keys

Press the + key to make the contrast, color intensity and brightness stronger or the – key to make them weaker.

16 LINE A indicator

17 LINE B indicator

18 VTR Indicator

19 CMPTR (computer) indicator

When the input source is selected, each indicator:

- Blinks if the indicators and keys excepting input source indicators illuminate.
- Illuminates if they are extinguished.

Note on the superimposing function

The PVM-2030/2530 can superimpose the CMPTR input source onto the other input source. For this function once the CMPTR input source has been selected, both the indicator of the CMPTR input source and the indicator of the input source selected just before the CMPTR will blink or illuminate.

Key illumination

For the keys **1** through **8**, **14** and **15**:

- While each key is pressed, it blinks, indicating that adjustment is going on.
- During adjustment, if the adjustment value reaches the limit, the blinking speed becomes slower.

Rear panel

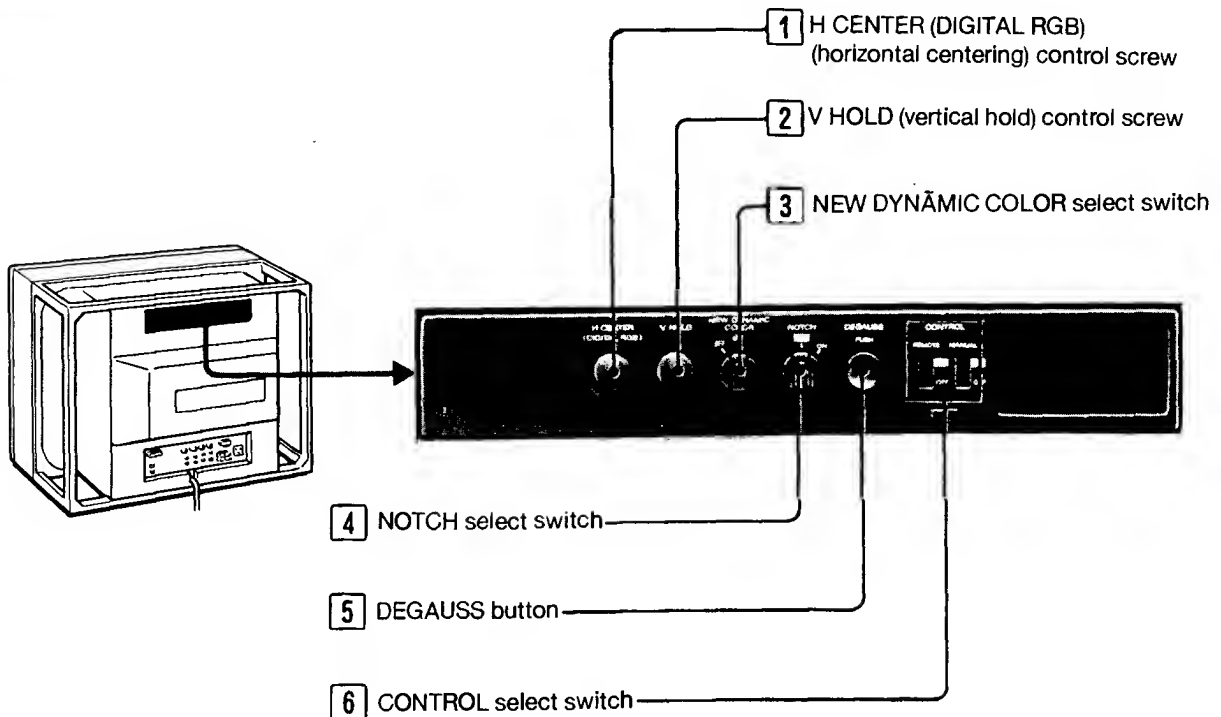

1 H CENTER (DIGITAL RGB) (horizontal centering) control

When the picture of DIGITAL RGB input is distorted horizontally, correct it with this control.

2 V HOLD (vertical hold) control

When the picture rolls vertically, correct it with this control.

3 NEW DYNAMIC COLOR select switch

Normally set to ON, which makes it possible to obtain natural skin tone and "blueish white".

4 NOTCH select switch

Normally set to OFF.

To eliminate notches forming along the horizontal boundary between the colors, set this switch to ON.

5 DEGAUSS button

Push this button for more than 5 seconds to demagnetize the screen.

(Just a touch may make the screen more magnetized.)

Wait for 10 minutes or more before activating this button again.

6 CONTROL select switches

Normally set to ON.

REMOTE CONTROL switch

Set this switch to ON to control the monitor with a Remote Commander.

If this switch is set to OFF, the remote control is not possible.

MANUAL CONTROL switch

Set this switch to ON to control the monitor manually.

To make the manual control of the control keys or switches on the front panel impossible, distinguish the indicators by pressing the CONTROL key on the front panel and set this switch to OFF.

(However remote control is possible if REMOTE CONTROL switch is set to ON.)

Connectors

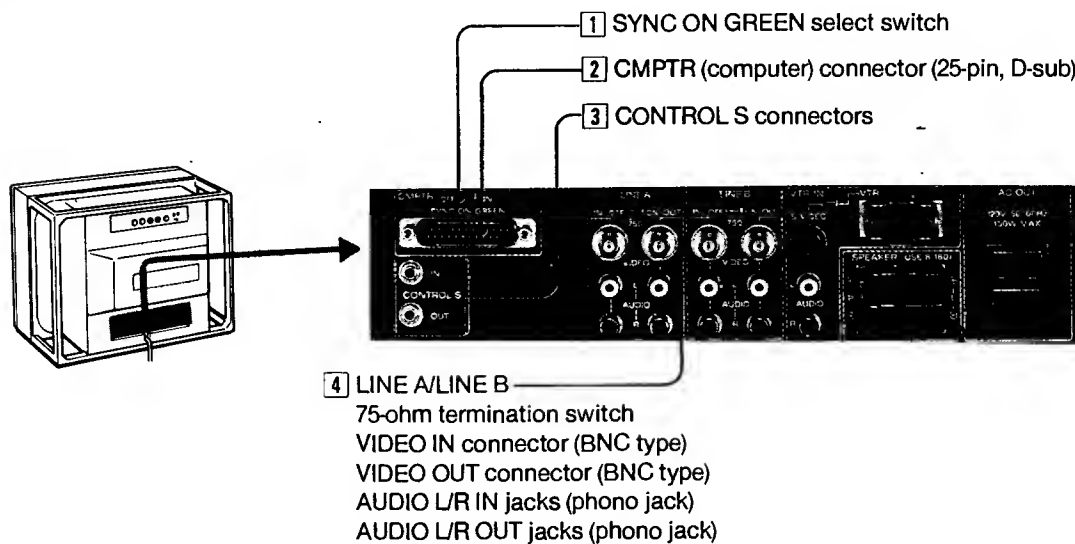

1 SYNC ON GREEN select switch

When an RGB input source is connected to CMPTR connector, set this switch to:

ON to synchronize with the sync signal on G-signal.
OFF to synchronize with H.V. sync signal or composite sync signal.

2 CMPTR (computer) connector (25-pin, D-sub)

Connect to a microcomputer with digital or analog RGB outputs.

For the pin assignment, refer to SPECIFICATIONS.

3 CONTROL S IN/OUT connectors

Connect to the CONTROL S connectors of a VTR or several monitors.

It is then possible to control the system with a single Remote Commander.

4 LINE A/LINE B

VIDEO IN connector (BNC type)

AUDIO L/R IN jacks (phono jack)

Connect to the video and audio outputs of a VTR or a camera.

VIDEO OUT connector (BNC type)

AUDIO L/R OUT jacks (phono jack)

Loop-through outputs of the IN connector and jacks.

Connect to the video and audio inputs of another monitor.

75-ohm termination switch

When only the VIDEO IN connector is used (nothing is connected to the VIDEO OUT connector), set this switch to ON.

When both connectors are used together for a loop-through connection), set this switch to OFF.

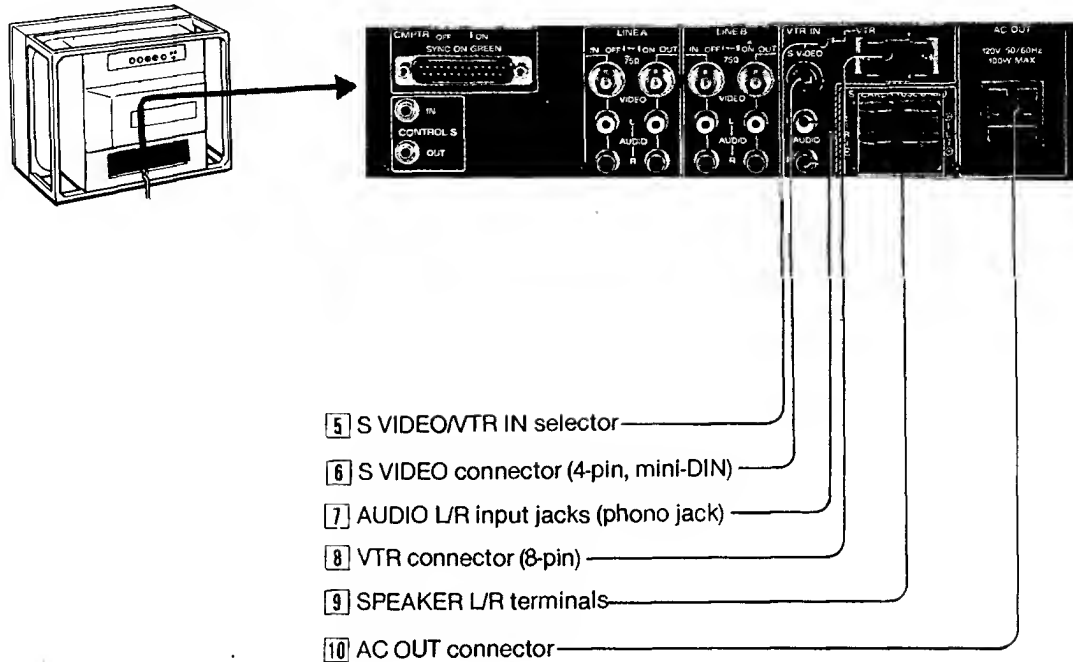

5 S VIDEO/VTR IN selector

To input the video/audio signals from S VIDEO/AUDIO connectors, set this to S VIDEO. To input the video/audio signals from the VTR connector, set this switch to VTR IN.

6 S VIDEO connector (4-pin, mini-DIN)

Connect to the VTR with an S VIDEO output connector.

7 AUDIO L/R Input jacks (phono Jack)

Connect to the audio outputs of a VTR.

8 VTR connector (8-pin)

Connect to a VTR with an 8-pin TV connector.

9 SPEAKER (USE 8 - 16Ω) L/R terminals

Connect to speakers with 8 to 16 ohms impedance.

10 AC OUT (120 V, 50/60 Hz, 100 W MAX) connector

This outlet provides AC power of 100 W max. Only for a connected microcomputer.

Remote commander

MUTING button

Press this button to mute the sound.
Press this button again to cancel muting.
• When muting is cancelled, the volume returns to the level before muting.

LINE A button **

CMPTTR (computer) button **

PICTURE control buttons *

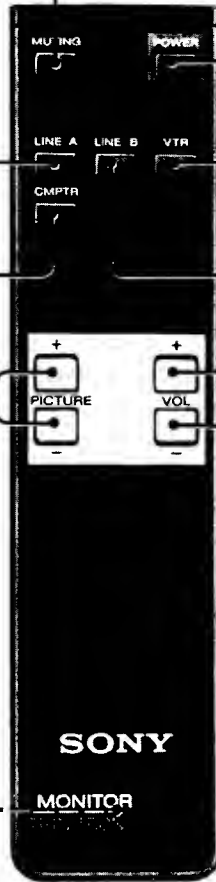

POWER switch *

VTR button **

LINE B button **

VOL (Volume) control buttons *

* The function of these buttons is the same as those on the front panel.

** To select LINE A, LINE B, VTR or CMPTTR for the input source, press the corresponding button.

Battery compartment

Insert 2 size "AA" batteries supplied (IEC designation R6) with the correct polarity.

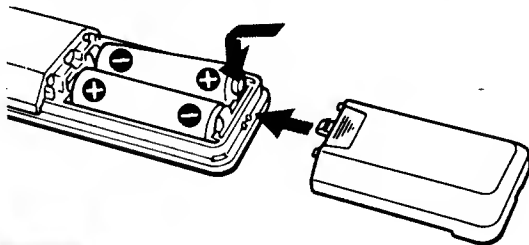

Notes

- In normal operation, batteries will last up to half a year. If the set does not operate properly, the batteries might be exhausted. Replace all with new ones.
- To avoid damage from possible battery leakage, remove the batteries for extended unused periods.
- Be sure that there are no obstructions between the Commander and the TV.

Operable range

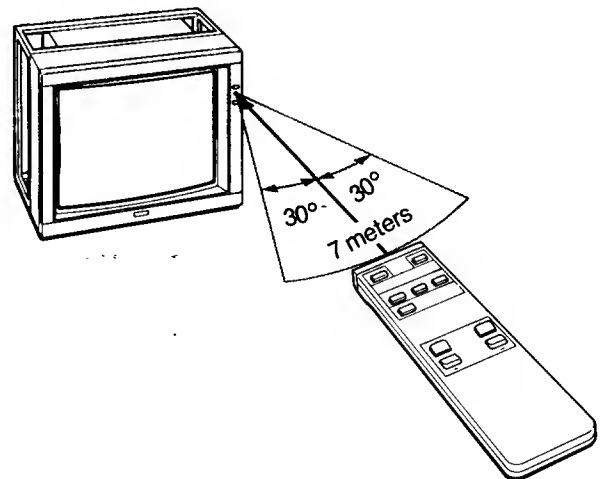

SYSTEM CONNECTIONS

CONNECTING A VTR

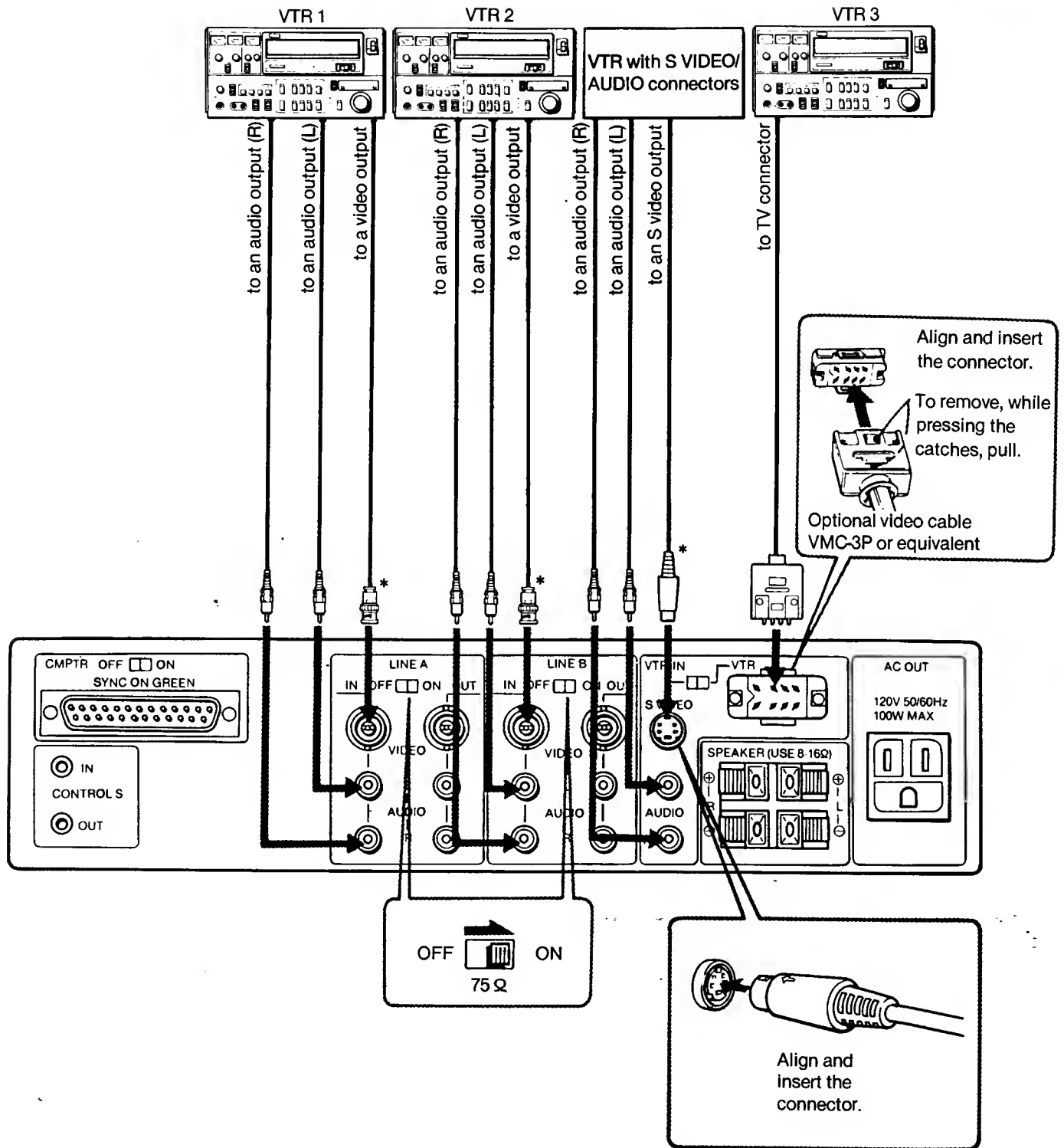

* If the connected VTR's video output is an RCA phono jack, use the supplied BNC-Phono adaptor plug.

CONNECTING A VIDEO CAMERA

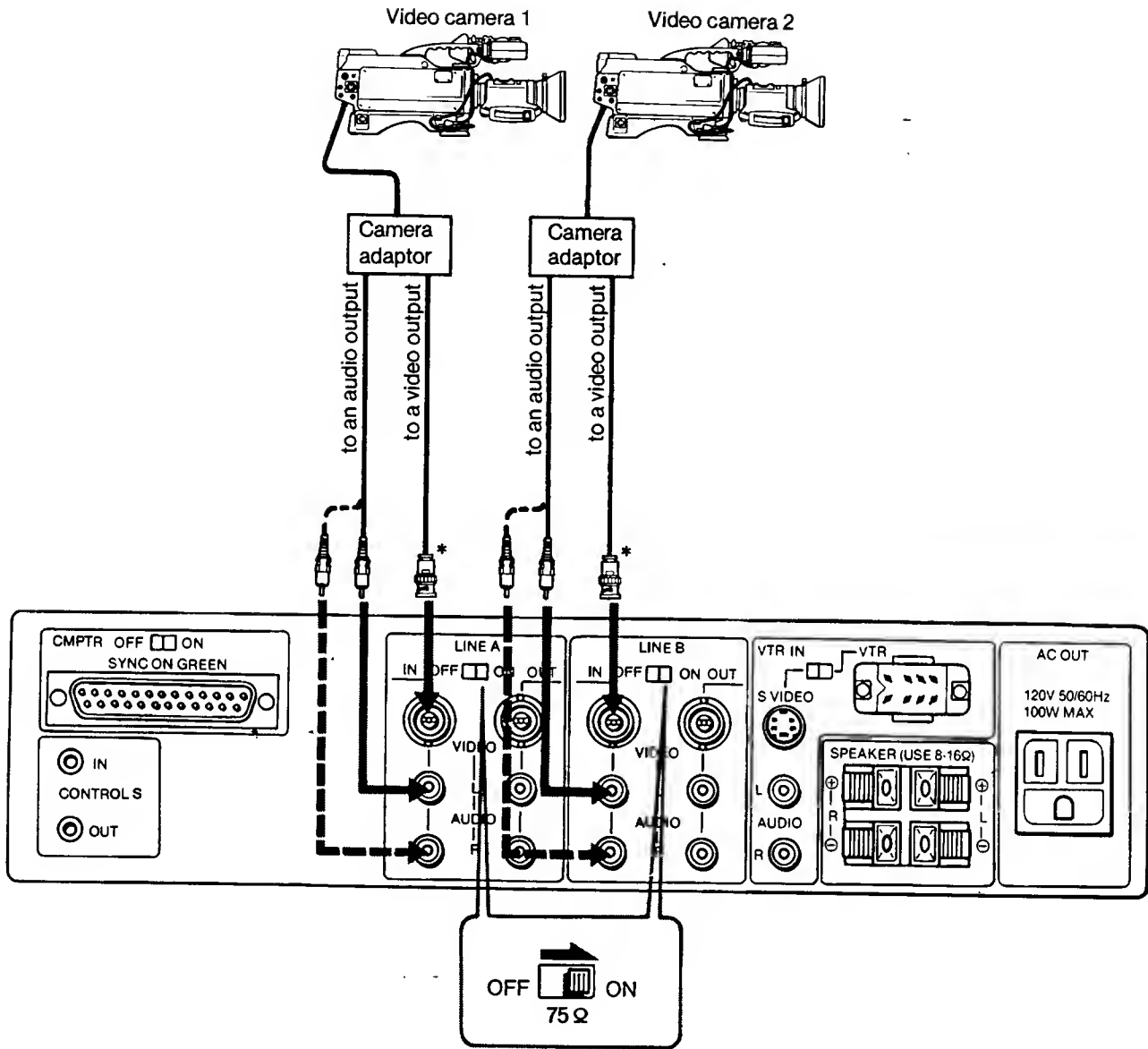

* If the connected camera adaptor's video output is an RCA phono jack, use the supplied BNC-Phono adaptor plug.

CONNECTING SEVERAL MONITORS

A loop-through connection is convenient for monitoring the same signal on other monitors. Up to 10 monitors can be connected. It is recommended to use a signal distributor when several monitors are connected.

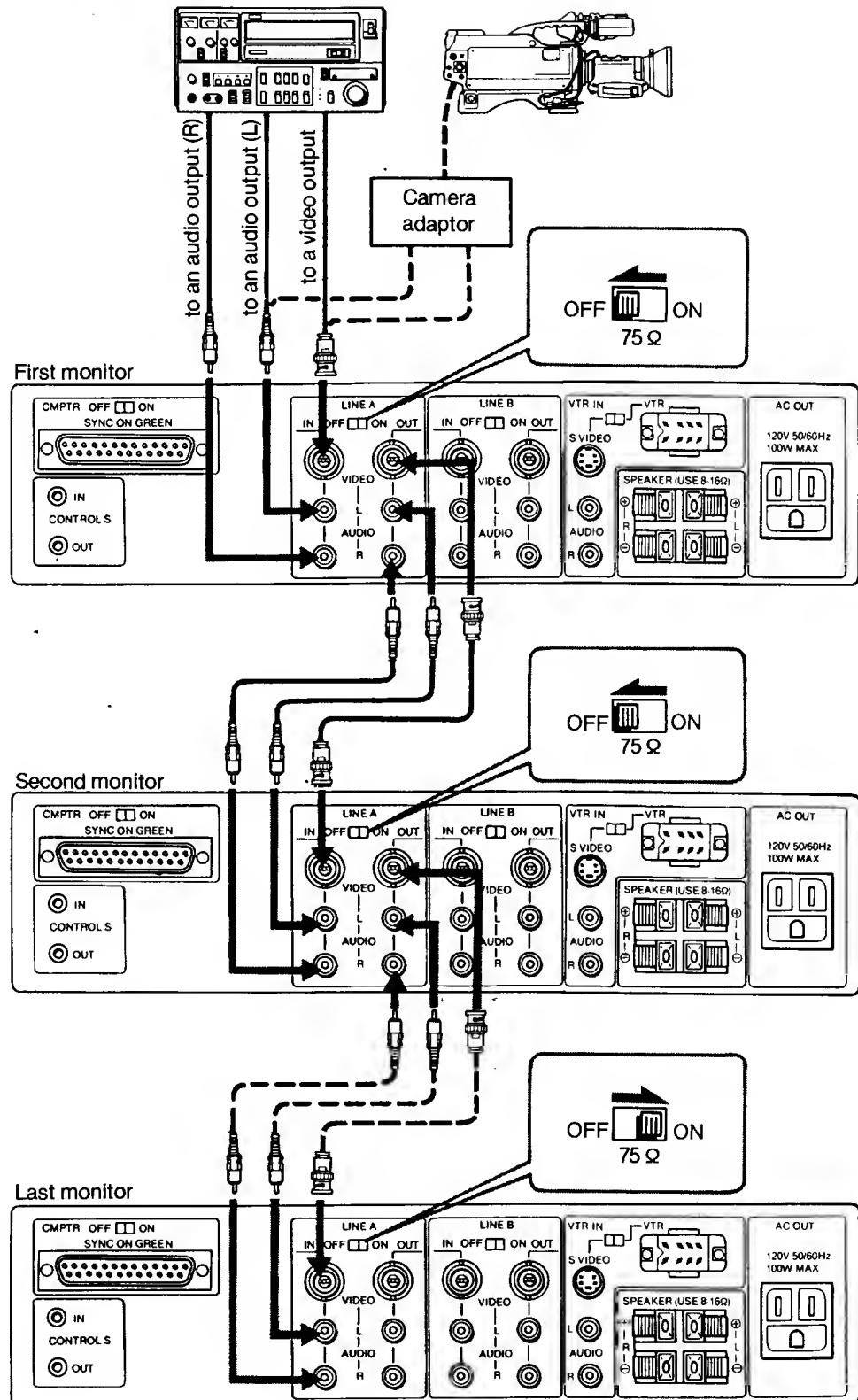

CONTROL S connection

The following connections allow remote control of several monitors and a VTR through a single monitor.

Example 1

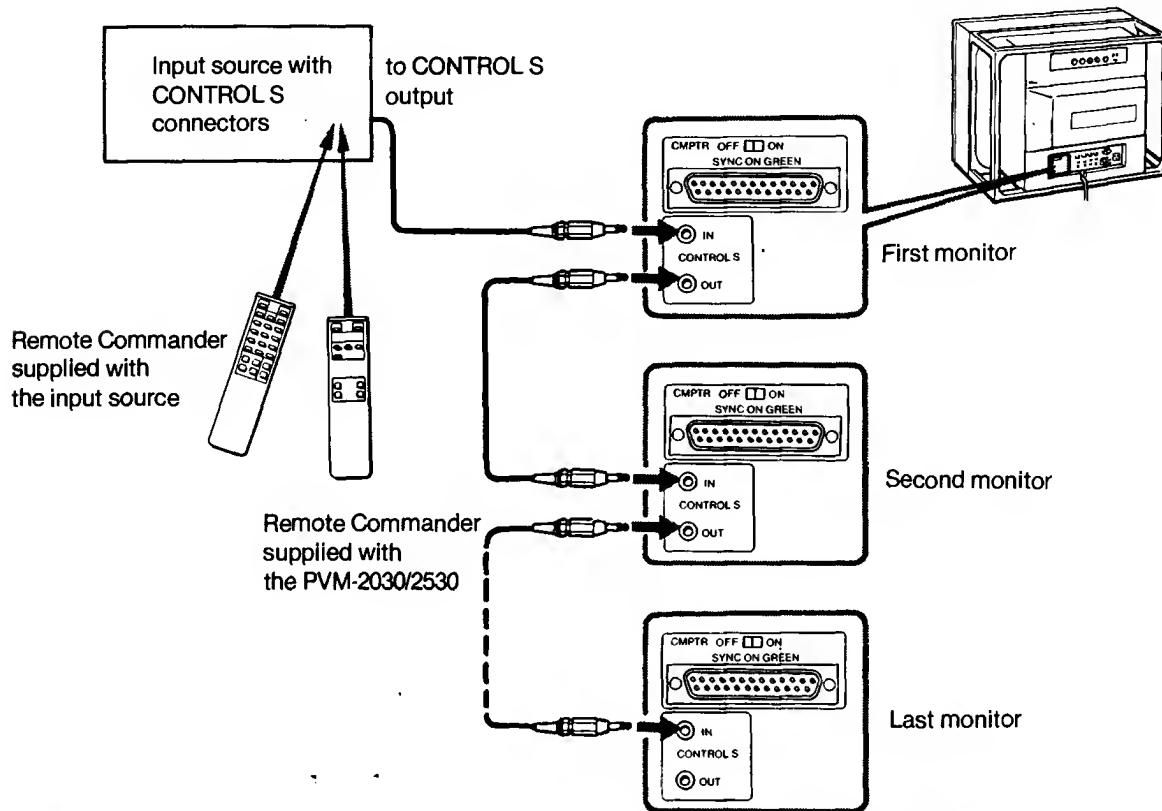

Example 2

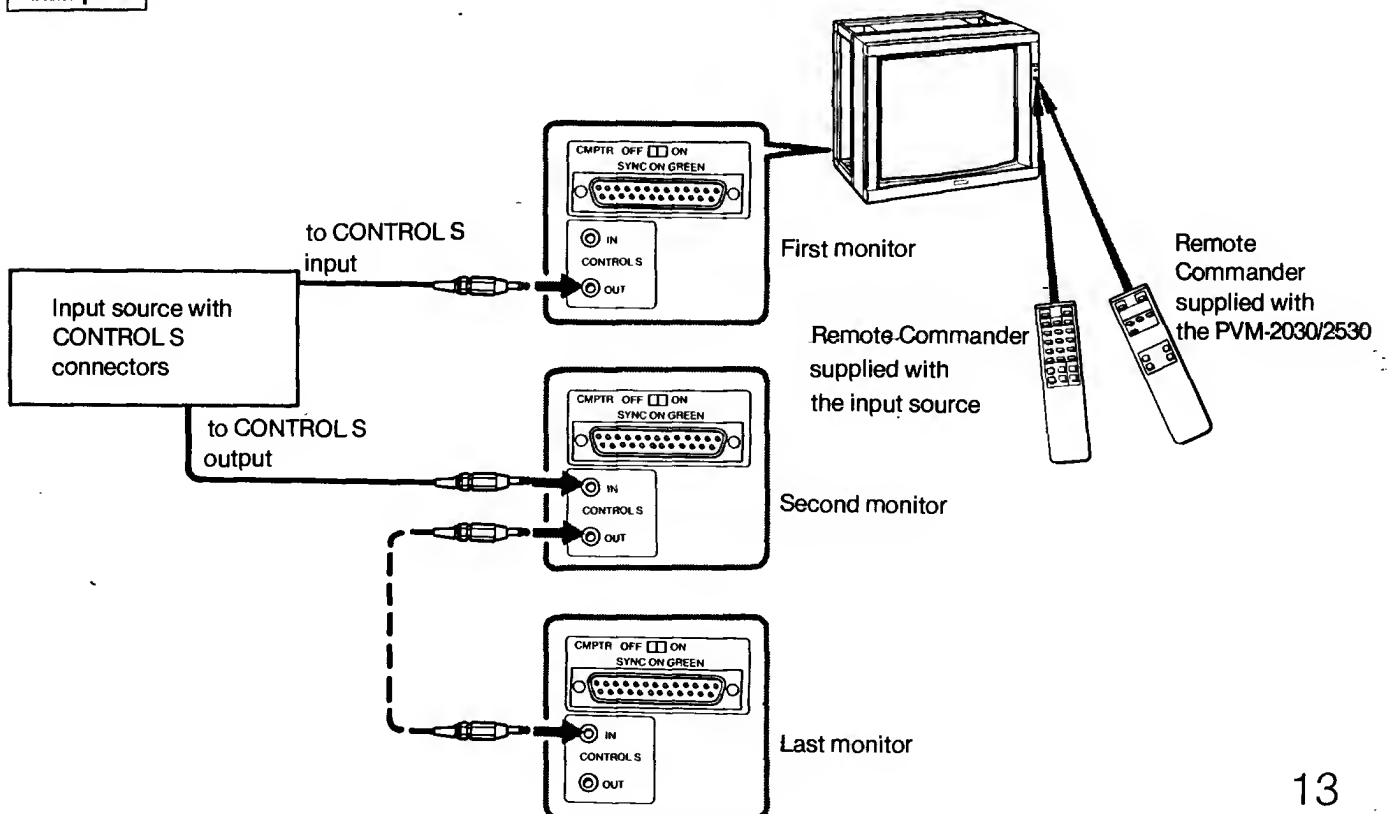

Note

Do not use the following loop connections.

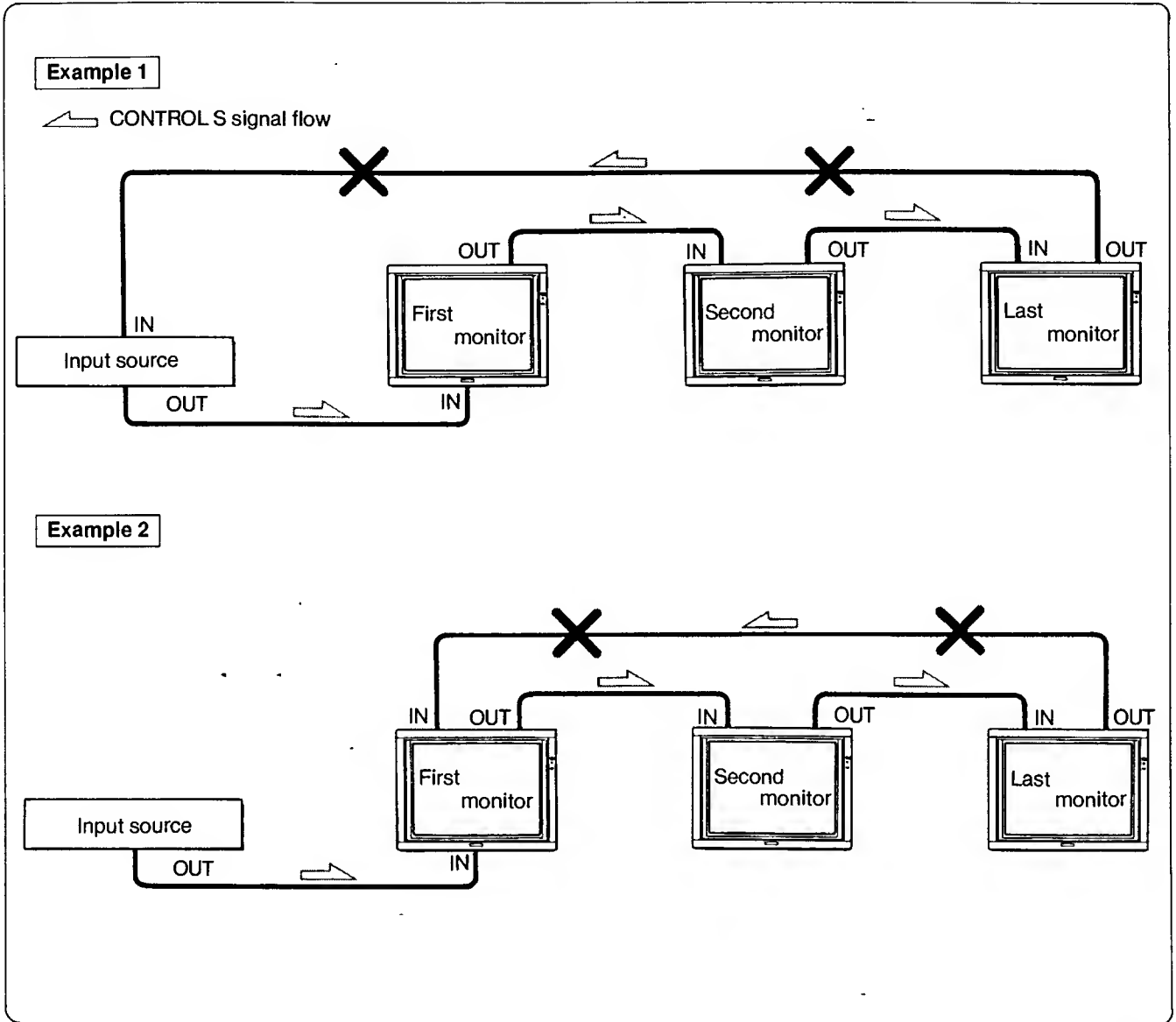

CONNECTING A MICROCOMPUTER

When you connect a microcomputer to this monitor, attach the supplied ferrite core. If you do not do this, this monitor will not conform to mandatory FCC standards.

2 Attach the ferrite core.

- ① Set the cord inside the ferrite core (supplied).
- ② Close the lid tightly until the clamps click.
- ③ Loop a plastic binder (supplied) at the far end of the core.

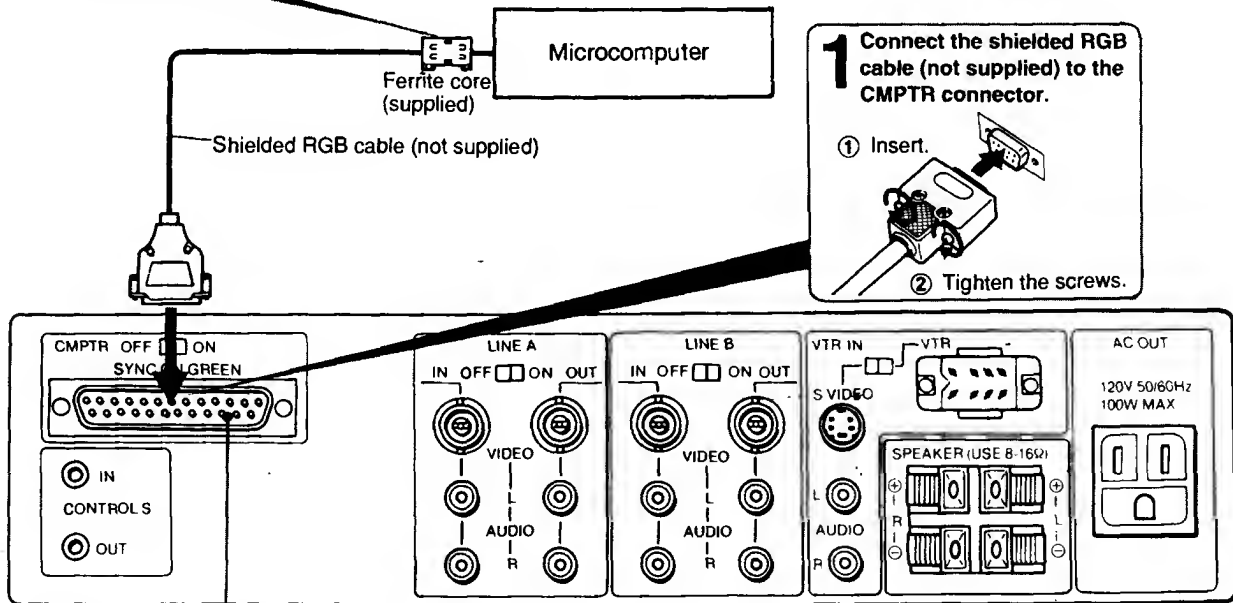
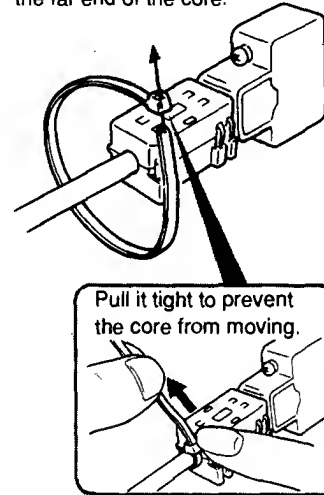
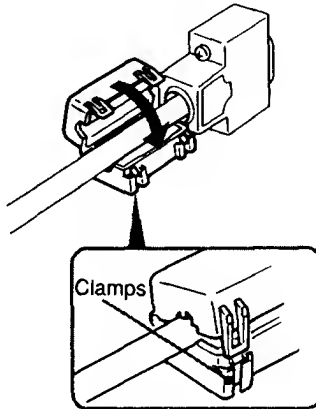
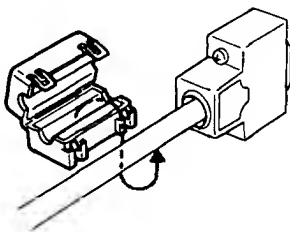

For signal to be connected, see "SPECIFICATIONS" on page 17.

When a microcomputer has only a composite video output connector, connect it to the LINE A or LINE B VIDEO IN connector.

SPECIFICATIONS

| | | | |
|-------------------------|---|---|--|
| Color system | NTSC system | Inputs | |
| Picture tube | Trinitron tube | VIDEO IN: | LINE A/B: BNC connector composite video, 1 Vp-p \pm 6 dB, sync negative, 75-ohms termination switchable |
| | PVM-2030: Approx. 50.6 cm picture measured diagonally, 100-degree deflection, AG Pitch 0.55 mm | | VTR: 8-pin connector, composite video, 1 Vp-p \pm 6 dB, sync negative, 75-ohms terminated |
| | PVM-2530: Approx. 63.5 cm picture measured diagonally, 100-degree deflection, AG Pitch 0.73 mm | | S VIDEO: 4-pin, mini-DIN Y (luminance signal); 1 Vp-p, 75-ohms, unbalanced, sync negative C (chrominance signal); 0.286 Vp-p (burst signal), 75-ohms |
| Resolution | VTR inputs: 560 TV lines RGB inputs: 640 \times 200 dots (2 000 characters) | AUDIO IN: | LINE A/B: Phono jack, -5 dBs, high impedance VTR: 8-pin connector, -5 dBs, high impedance AUDIO (for S video): Phono jack, -5 dBs, high impedance |
| Color temperature | 9300°K (When the NEW DYNAMIC COLOR select switch is set to OFF.) | CMPTR | 25-pin connector (See "Pin assignment") |
| Frequency response | 10 MHz (-3 to +4 dB, RGB) 6 MHz (-3 dB, composite video) | Outputs | |
| Horizontal linearity | Less than \pm 5% | VIDEO OUT: | LINE A/B: BNC connector |
| Vertical linearity | Less than \pm 5% | AUDIO OUT: | LINE A/B: Phono jack |
| Line pull range | Horizontal: \pm 500 Hz Vertical: -8 Hz | SPEAKER: | PVM-2030: 8 ohms (7 W + 7 W) PVM-2530: 8 ohms (15 W + 15 W) |
| Overscan of the picture | Less than +7% | Power requirements | 120 V AC, 50/60 Hz |
| Input return loss | More than 35 dB up to 4 MHz | Power consumption | PVM-2030: 150 W max PVM-2530: 180 W max |
| Zooming | Within 5% | Dimensions | PVM-2030: Approx. 516 \times 409 \times 481 mm (w/h/d) (20 ³ / ₈ \times 16 ¹ / ₈ \times 19 inches) PVM-2530: Approx. 653 \times 508 \times 491 mm (w/h/d) (25 ³ / ₄ \times 20 \times 19 ³ / ₈ inches) |
| Convergence | Central area: PVM-2030: within 0,9 mm PVM-2530: within 1,0 mm Periphery: PVM-2030: within 1,7 mm PVM-2530: within 1,8 mm | Weight | PVM-2030: Approx. 30.5 kg (67 lb 4 oz) PVM-2530: Approx. 53 kg (116 lb 14 oz) |
| | | Supplied accessories | |
| | | Remote commander RM-739, with 2 batteries | |
| | | (IEC designation R6) | 1 |
| | | BNC-Phono adaptor plug | 4 |
| | | Ferrite core | 1 |
| | | Plastic binder | 1 |
| | | Optional accessories | |
| | | SU-539, TV stand | |
| | | SU-541 TV stand | |
| | | SS-X6A speaker system | |
| | | APM-X5A speaker system | |

CMPTR connector (25-pin)
Pin assignment

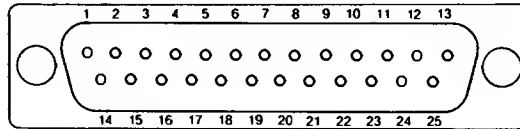

| Pin No. | Signal | Signal level |
|---------|----------------------------|--|
| 1* | IBM select | High state (5 V): IBM mode Low state: 3 Bit TTL |
| 2 | Audio select | High state (5 V or open): Audio inputs from pin 13. Low state (less than 0.4 V): Audio inputs from the LINE A/LINE B AUDIO IN jacks or VTR connector |
| 3 | H. sync or composite sync | Negative polarity When the high state is selected at pin 9: 1 Vp-p, 75-ohm terminated When the low state is selected at pin 9: TTL level |
| 4 | Blue input | Positive polarity When the high state is selected at pin 9: Analog signal (0.7 Vp-p, 75-ohm terminated, non sync 1 Vp-p, 75-ohm terminated, with sync on G-signal) When the low state is selected at pin 9: Digital signal (TTL level) |
| 5 | Green input | |
| 6 | Red input | |
| 7 | No connection | — |
| 8 | | |
| 9* | Analog/digital mode select | High state (open): Analog signal (0.7 Vp-p) Low state (ground): Digital signal (TTL level) |
| 10 | RGB/NORMAL mode select | High state (5 V or open): RGB inputs from a microcomputer Low state (ground): Composite video inputs from the LINE A/LINE B VIDEO IN or VTR connector |
| 11 | V-sync | Negative polarity TTL level |
| 12 | Blanking | High state (5 V or open): Video inputs from a microcomputer only Low state (ground): Composite video input from the LINE A/LINE B VIDEO IN or VTR connector During the low state, the video signal from the microcomputer is blanked and the composite video signal from the LINE A/LINE B VIDEO IN or VTR connector is superimposed over the signal from the microcomputer. |
| 13 | Audio input | Input level -5 dB (100% modulation), input impedance more than 47 k ohms |
| 14 | No connection | — |
| 15-24 | Ground | |
| 25* | IBM luminance signal | Positive polarity When the high state is selected at pin 1: TTL level When the low state is selected at pin 1: Low state (ground) |

* Examples for microcomputer connections

| Pin No. | 1 | 9 | 25 |
|-------------------|------------|------------|----------------------|
| Microcomputer | — | High state | — |
| Analog signal | — | High state | — |
| IBM computer | High state | Low state | IBM luminance signal |
| TTL 3BIT computer | Low state | Low state | Low state |

While the information given is true at the time of printing, small production changes in the course of our company's policy of improvement through research and design might not necessarily be indicated in the specifications. We would ask you to check with your appointed Sony dealer if clarification on any point is required.

Design and specifications subject to change without notice.

TROUBLESHOOTING

If these symptoms occur when you begin operation, follow the suggestions below.

| SYMPTOMS | CORRECTIONS |
|--|--|
| No controllable keys although the POWER switch is turned on. | • Press the CONTROL key. |
| No indication appears although the CONTROL key is pressed. | • Set the MANUAL CONTROL switch on the rear panel to ON. |
| Remote control is not possible. | • Set the REMOTE CONTROL switch on the rear panel to ON. |

If the problem still cannot be solved, contact your authorized Sony dealer.