

Preliminary Specifications

Final Specifications

Module	15.6" FHD Color TFT-LCD
Model Name	
Note	LED backlight with driving circuit design

Customer	Date
Checked & Approved by	Date

Approved by	Date
<i>eh</i>	<u>05/15/2015</u>
Prepared by	Date
<u><i>Sa</i></u>	<u>05/15/2015</u>

Version and Date	Page	Old Description	New Description	Remark
0.0 2015/05/15	All	1 st Edition for Customers		

Product Specification

1. Handling Precautions

- 1) Since front polarizer is easily damaged, please be cautious and not to scratch it.
- 2) Be sure to turn off power supply when inserting or disconnecting from input connector.
- 3) Wipe off water drop immediately. Long contact with water may cause discoloration or spots.
- 4) When the panel surface is soiled, wipe it with absorbent cotton or soft cloth.
- 5) Since the panel is made of glass, it may be broken or cracked if dropped or bumped on hard surface.
- 6) To avoid ESD (Electro Static Discharge) damage, be sure to ground yourself before handling TFT-LCD Module.
- 7) Do not open nor modify the module assembly.
- 8) Do not press the reflector sheet at the back of the module to any direction.
- 9) In case if a module has to be put back into the packing container slot after it was taken out from the container, do not press the center of the LED light bar edge. Instead, press at the far ends of the LED light bar edge softly. Otherwise the TFT Module may be damaged.
- 10) At the insertion or removal of the Signal Interface Connector, be sure to rotate nor tilt the Interface Connector of the TFT Module.
- 11) TFT-LCD Module is not allowed to be twisted & bent even force is added on module in a very short time. Please design your display product well to avoid external force applying to module by end-user directly.
- 12) Small amount of materials without flammability grade are used in the TFT-LCD module. The TFT-LCD module should be supplied by power complied with requirements of Limited Power Source (IEC60950 or UL1950), or be applied exemption.
- 13) Severe temperature condition may result in different luminance, response time and lamp ignition voltage.
- 14) Continuous operating TFT-LCD display under low temperature environment may accelerate lamp exhaustion and reduce luminance dramatically.
- 15) The data on this specification sheet is applicable when LCD module is placed in landscape position.
- 16) Continuous displaying fixed pattern may induce image sticking. It's recommended to use screen saver or shuffle content periodically if fixed pattern is displayed on the screen.

Product Specification

2. General Description

G156HTN02.0 is a Color Active Matrix Liquid Crystal Display composed of a TFT LCD panel, a driver circuit, and LED backlight system. The screen format is intended to support the 16:9 FHD, 1920(H) x1080(V) screen and 16.2M colors (RGB 6-bits+2FRC data driver) with LED backlight driving circuit.

G156HTN02.0 is designed for a display unit of industrial machine.

2.1 General Specification

The following items are characteristics summary on the table at 25 °C condition:

Items	Unit	Specifications			
Screen Diagonal	[inch]	15.6"			
Active Area	[mm]	344.16(H) x 193.59(V)			
Pixels H x V		1920 x 3(RGB) x 1080			
Pixel Pitch	[mm]	0.17925 x 0.17925			
Pixel Format		R.G.B. Vertical Stripe			
Display Mode		TN Mode, Normally White			
White Luminance (Center) (ILED=50mA,Note: ILED is LED current)	[cd/m ²]	400 Typ. 320 Min.			
Luminance Uniformity		TBD (5 points, Max.)			
Contrast Ratio		500:1 (Typ.)			
Response Time	[ms]	8 (Typ.)/ 16 (Max.)			
Nominal Input Voltage VDD	[Volt]	+3.3 (Typ.)			
LCD Power Consumption	[Watt]	3.76 W (Max.)			
LED Power Consumption	[Watt]	10.6 W (Max.)			
Weight	[Grams]	TBD (Max.)			
Physical Size Without bracket.	[mm]		Min.	Typ.	Max.
		Length	363.3	363.8	364.3
		Width	215.4	215.9	216.4
		Thickness	8.8	9.3	9.8
Electrical Interface		Two channel LVDS			
Surface Treatment		Anti-glare (Haze=25%)			
Support Color		16.2M Colors (RGB 6-bits +2FRC)			
Temperature Range Operating Storage (Non-Operating)	[°C] [°C]	-10 to +70 -20 to +70			

Product Specification

2.2 Optical Characteristics

Temperature: 25°C (Roc)

Item	Unit	Conditions	Min.	Typ.	Max.	Note
7 YbfU@a]bUbW @981) \$a 5	WX#a &		' &\$	(\$ \$!!!	%ž(ž)
J]k]b['5b['Y'	XY[fYY	< c f]nc bU'' fF][\hŁ 7 F'1 %\$' fŁZŁ	*\$	+\$!!!	(ž-
		J Yf]WU'' fl ddYfŁ 7 F'1 %\$' fŁk YfŁ	()	*\$!!!	
@ a]bUbW '1 b]cfa]m) 'Dc]bŁg	!!!	!!!	H68	%ž' ž(
		% 'Dc]bŁg	!!!	!!!	H68	&ž' ž(
7 cbfUghFUhŁ			(\$ \$)	\$ \$!	(ž*
7 fcgg'U'_			!!!	!!!	((ž+
FYgdcbgY 'H a Y	a gYW	F]b['ž : U'']b[!!!	,	%*	(ž,
7 c'cf# 7 \fca U]W]m 7 ccX]bU]g	FYX	Fl	H68	H68	H68	(
		Fm	H68	H68	H68	
	; fYYb	; l	H68	H68	H68	
		; m	H68	H68	H68	
	6i Y	6l	H68	H68	H68	
		6m	H68	H68	H68	
	K \]hY	K l	H68	1 \$''' %	H68	
		K m	H68	1 \$''' &-	H68	
	BHG7	l	!	+&	!	

Product Specification

Note 1: 5 points position (Ref: Active area)

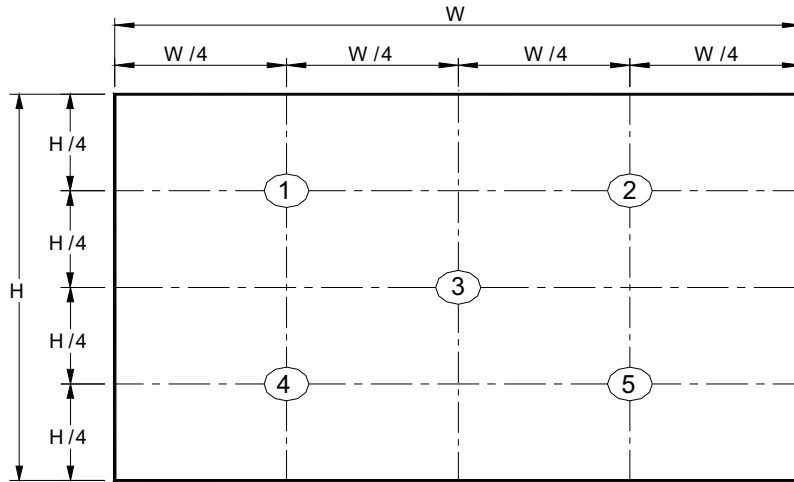

Note 2: 13 points position (Ref: Active area)

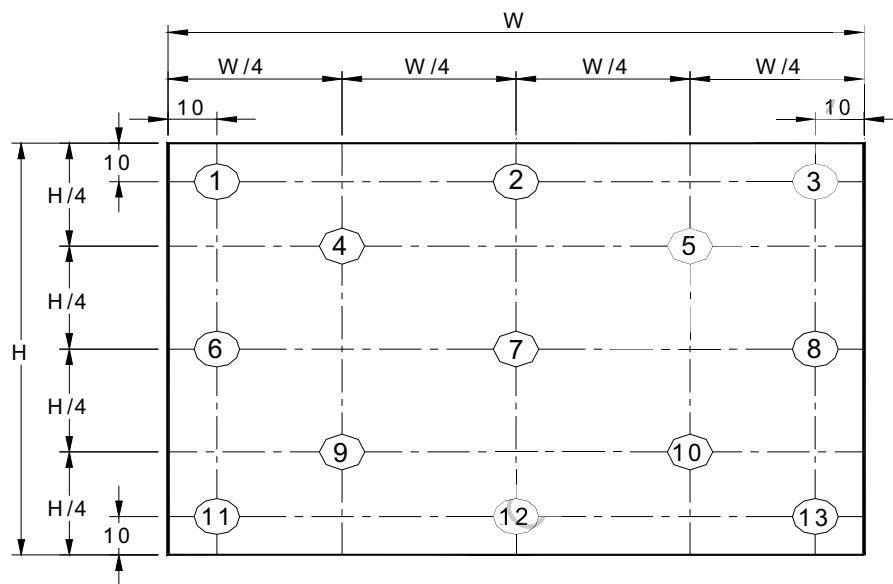

Note 3: The luminance uniformity of 5 or 13 points is defined by dividing the maximum luminance values by the minimum test point luminance

$$\delta_{w5} = \frac{\text{Maximum Brightness of five points}}{\text{Minimum Brightness of five points}}$$

$$\delta_{w13} = \frac{\text{Maximum Brightness of thirteen points}}{\text{Minimum Brightness of thirteen points}}$$

Product Specification

Note 4: Measurement method

The LCD module should be stabilized at given temperature for 30 minutes to avoid abrupt temperature change during measuring. In order to stabilize the luminance, the measurement should be executed after lighting Backlight for 30 minutes in a stable, windless and dark room, and it should be measured in the center of screen.

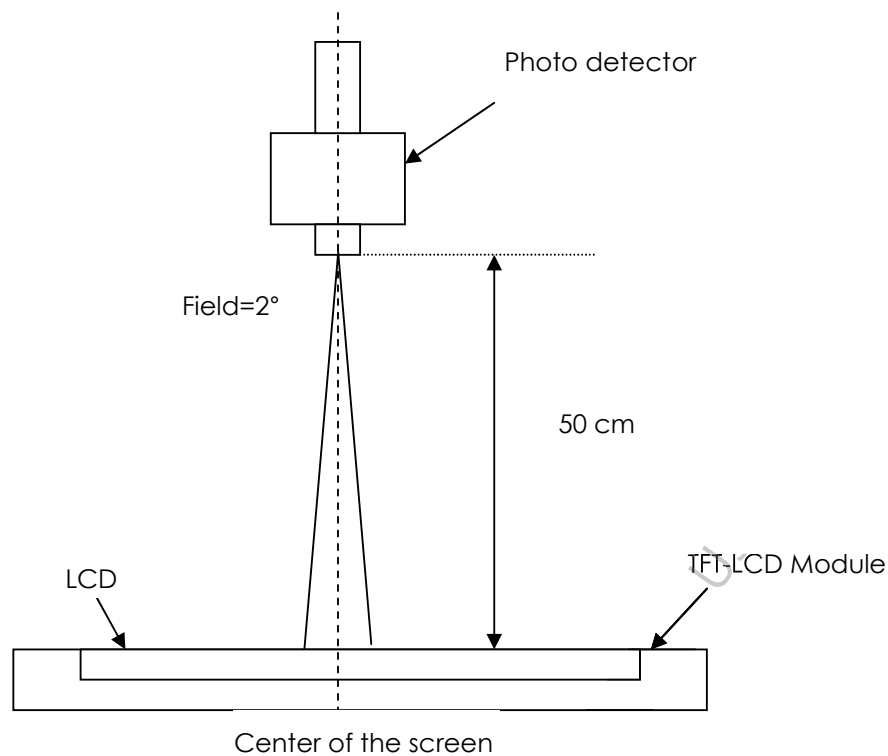

Note 5 : Definition of Average Luminance of White (Y_L):

Measure the luminance of gray level 63 at 5 points , $Y_L = [L(1) + L(2) + L(3) + L(4) + L(5)] / 5$

$L(x)$ is corresponding to the luminance of the point X at Figure in Note (1).

Note 6 : Definition of contrast ratio:

Contrast ratio is calculated with the following formula.

$$\text{Contrast ratio (CR)} = \frac{\text{Brightness on the "White" state}}{\text{Brightness on the "Black" state}}$$

Product Specification

Note 7 : Definition of Cross Talk (CT)

$$CT = | Y_B - Y_A | / Y_A \times 100 (\%)$$

Where

Y_A = Luminance of measured location without gray level 0 pattern (cd/m²)

Y_B = Luminance of measured location with gray level 0 pattern (cd/m²)

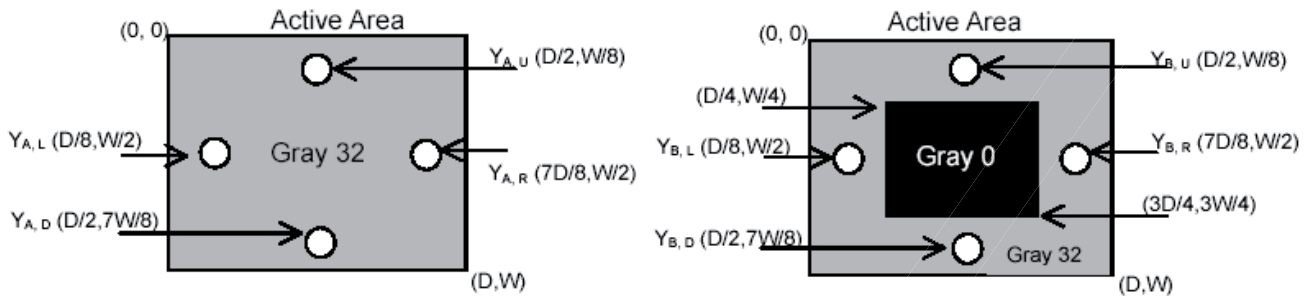

Note 8: Definition of response time:

The output signals of BM-7 or equivalent are measured when the input signals are changed from "Black" to "White" (falling time) and from "White" to "Black" (rising time), respectively. The response time interval between the 10% and 90% of amplitudes. Refer to figure as below.

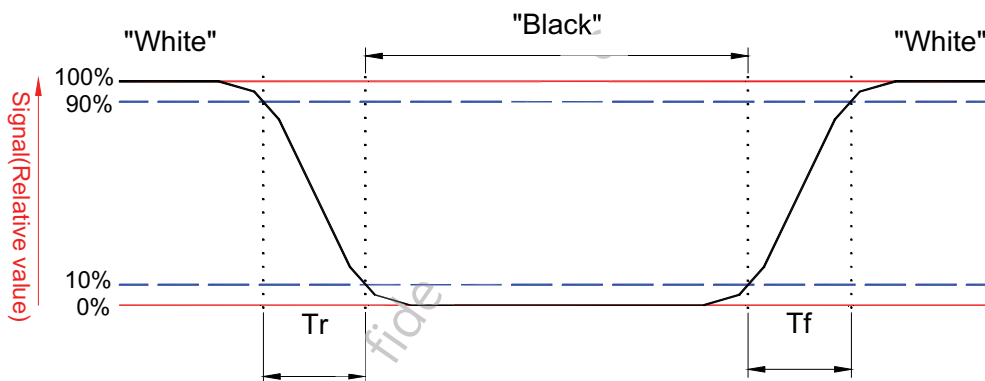

Product Specification

Note 9. Definition of viewing angle

Viewing angle is the measurement of contrast ratio >10, at the screen center, over a 180° horizontal and 180° vertical range (off-normal viewing angles). The 180° viewing angle range is broken down as follows; 90° (θ) horizontal left and right and 90° (Φ) vertical, high (up) and low (down). The measurement direction is typically perpendicular to the display surface with the screen rotated about its center to develop the desired measurement viewing angle.

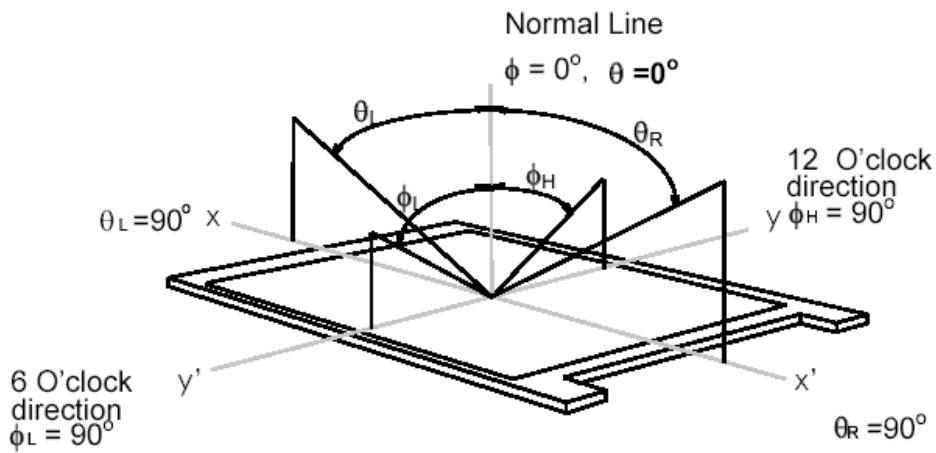

Crosstalk above for viewing angle under 3D mode is defined as below;

$$\text{Crosstalk_Left(\%)} = \frac{L_{\text{black}}R_{\text{white}}}{L_{\text{white}}R_{\text{black}}}$$

Where

Crosstalk_Left(%) means left eye crosstalk;

L_{black} means left eye black signal;

R_{white} means right eye white signal;

L_{white} means left eye white signal;

R_{black} means right eye black signal;

Right eye crosstalk is defined by analogy.

Product Specification

3. Functional Block Diagram

The following diagram shows the functional block of the 15.6 inch Color TFT-LCD Module:

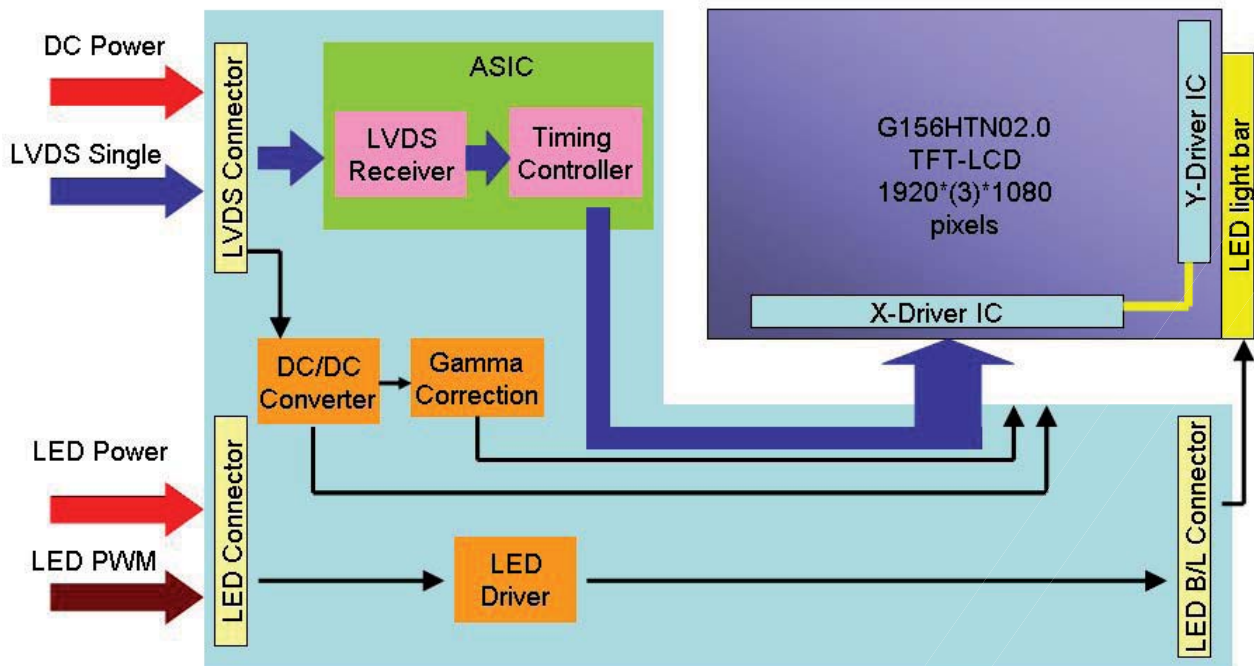

Product Specification

4. Absolute Maximum Ratings

An absolute maximum rating of the module is as following:

4.1 Absolute Ratings of TFT LCD Module

Item	Symbol	Min	Max	Unit	Conditions
Logic/LCD Drive	Vin	-0.3	+5.0	[Volt]	Note 1,2

4.2 Absolute Ratings of Environment

Item	Symbol	Min	Max	Unit	Conditions
Operating Temp.	TOP	0	+50	[°C]	Note 4
Operation Humidity	HOP	8	95	[%RH]	Note 4
Storage Temperature	TST	-20	+60	[°C]	Note 4
Storage Humidity	HST	5	95	[%RH]	Note 4

Note 1: At Ta (25°C)

Note 2: Permanent damage to the device may occur if exceed maximum values

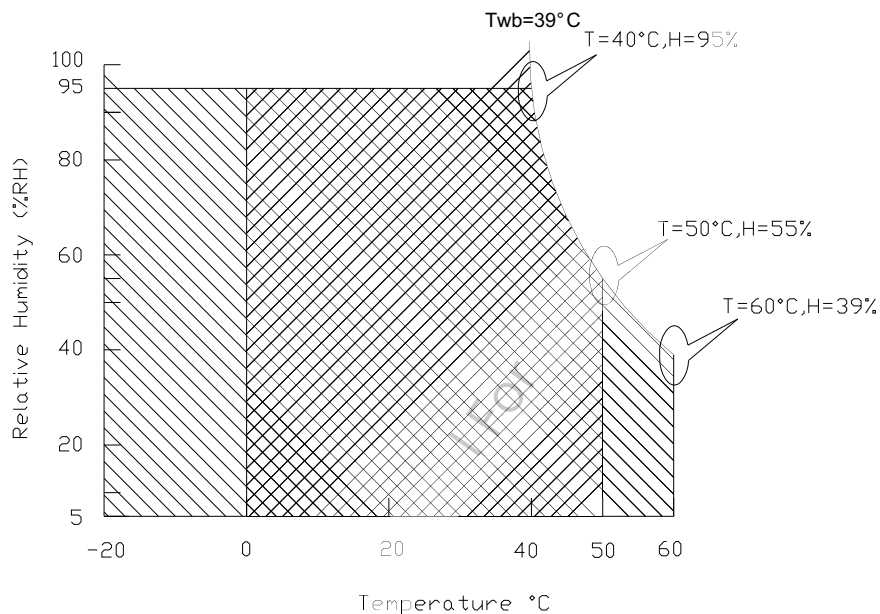

Note 3: LED specification refer to section 5.2

Note 4: For quality performance, please refer to AUO IIS (Incoming Inspection Standard)



Operating Range 

Storage Range

 + 

Product Specification

5. Electrical Characteristics

5.1 TFT LCD Module

5.1.1 Power Specification

Input power specifications are as follows;

The power specification are measured under 25°C and frame frequency under 60Hz

Symbol	Parameter	Min	Typ	Max	Units	Note
VDD	Logic/LCD Drive Voltage	3.0	3.3	3.6	[Volt]	
PDD	VDD Power	-	3.14	3.76	[Watt]	Note 1
IDD	IDD Current	-	950	1140	[mA]	Note 1
IRush	Inrush Current	-	-	TBD	[mA]	Note 2
VDDrp	Allowable Logic/LCD Drive Ripple Voltage	-	-	TBD	[mV] p-p	

Note 1: Maximum Measurement Condition : Red Pattern

Note 2: Measure Condition

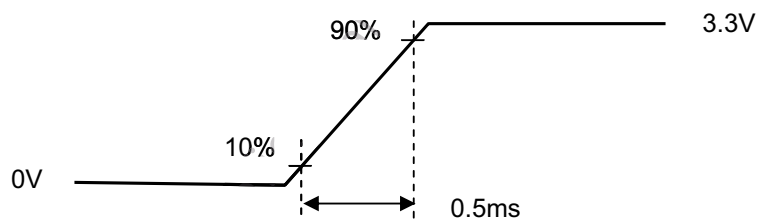
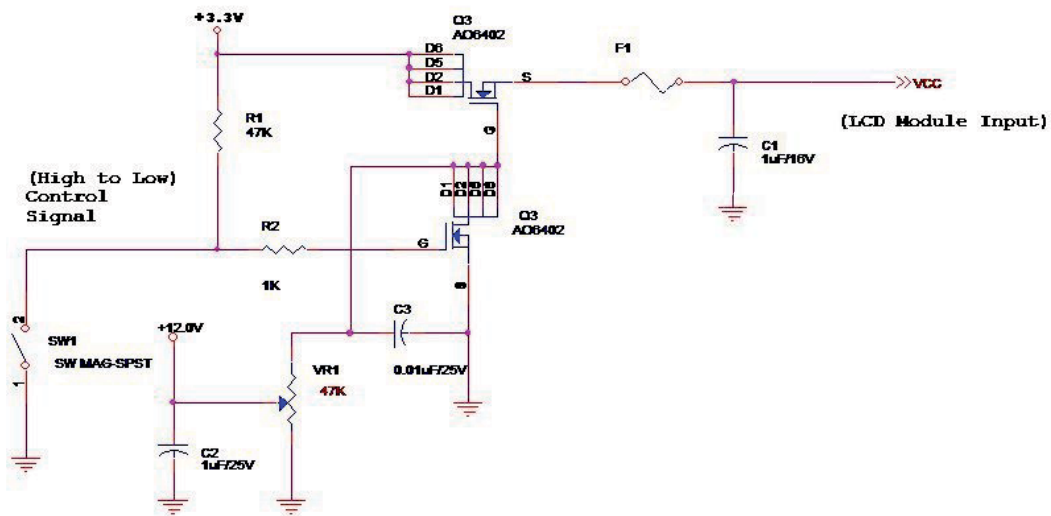

Vin rising time

Product Specification

5.1.2 Signal Electrical Characteristics

Input signals shall be low or High-impedance state when VDD is off.

Signal electrical characteristics are as follows;

Parameter	Condition	Min	Max	Unit
V_{TH}	Differential Input High Threshold ($V_{cm}=+1.2V$)	---	100	[mV]
V_{TL}	Differential Input Low Threshold ($V_{cm}=+1.2V$)	-100	---	[mV]
$ V_{ID} $	Differential Input Voltage	100	600	[mV]
V_{CM}	Differential Input Common Mode Voltage	1.125	1.375	[V]

Note 1: LVDS Signal Waveform

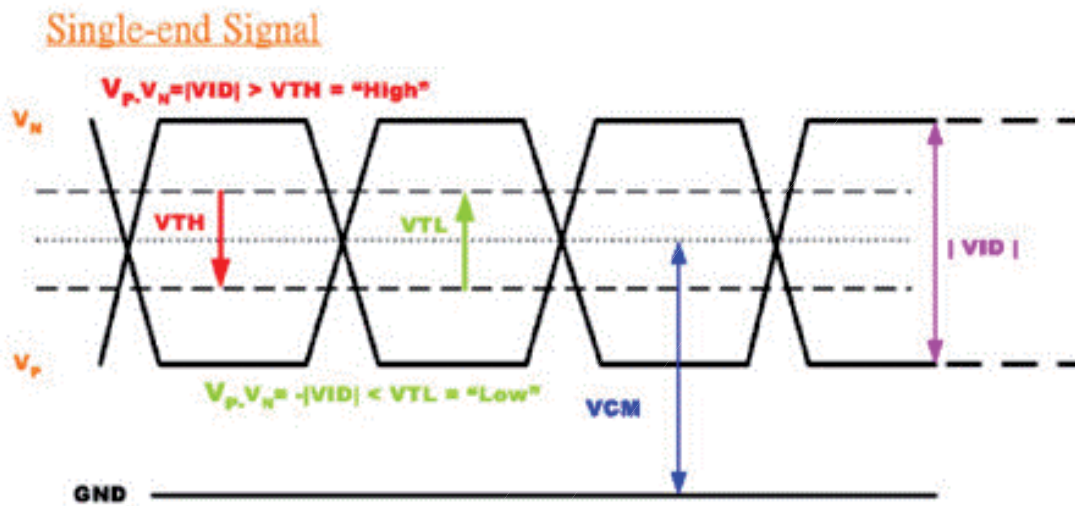

Product Specification

5.2 Backlight Unit

5.2.1 LED characteristics

Parameter	Symbol	Min	Typ	Max	Units	Condition
Backlight Power Consumption	PLED	-	-	10.6W	[Watt]	(Ta=25°C), Note 1
LED Life-Time	N/A	-	50,000	-	Hour	(Ta=25°C), Note 2

Note 1: Calculator value for reference $P_{LED} = V_F$ (Normal Distribution) * I_F (Normal Distribution) / Efficiency

Note 2: The LED life-time define as the estimated time to 50% degradation of initial luminous.

5.2.2 Backlight input signal characteristics

Parameter	Symbol	Min	Typ	Max	Units	Remark
LED Power Supply	VLED	10.8	12.0	13.2	[Volt]	Define as Connector Interface (Ta=25°C)
LED Enable Input High Level	VLED_EN	2.5	-	5	[Volt]	
LED Enable Input Low Level		-	-	0.8	[Volt]	
PWM Logic Input High Level	VPWM_EN	2.5	-	5	[Volt]	
PWM Logic Input Low Level		-	-	0.8	[Volt]	
PWM Input Frequency	FPWM	200	-	15K	Hz	
PWM Duty Ratio	Duty	5	-	100	%	

Product Specification

6. Signal Interface Characteristic

6.1 Pixel Format Image

Following figure shows the relationship of the input signals and LCD pixel format.

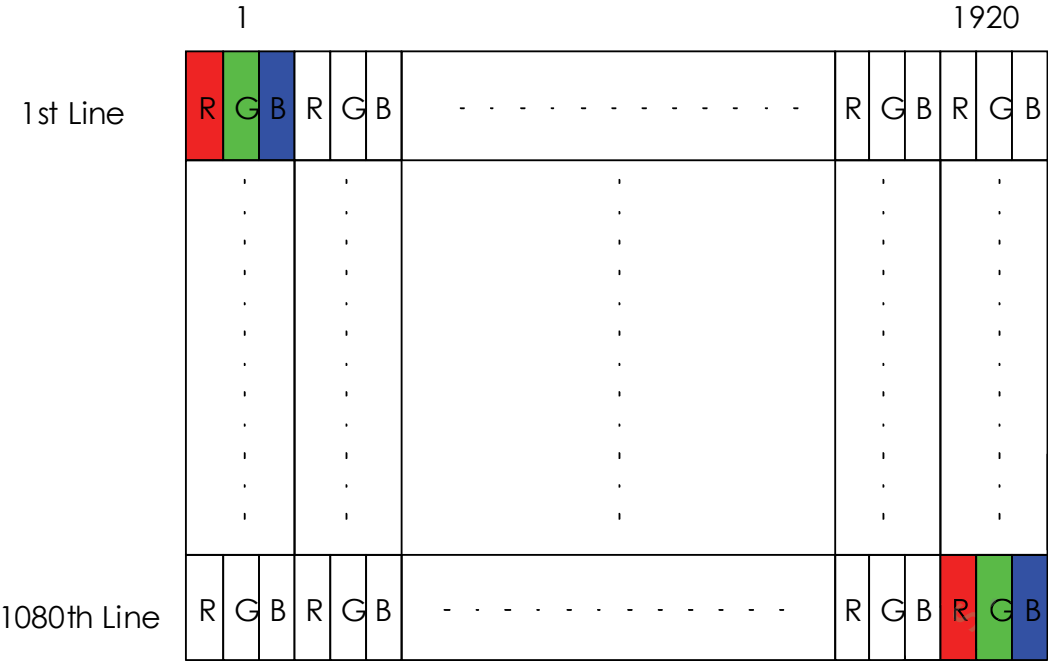

Product Specification

6.2 The Input Data Format

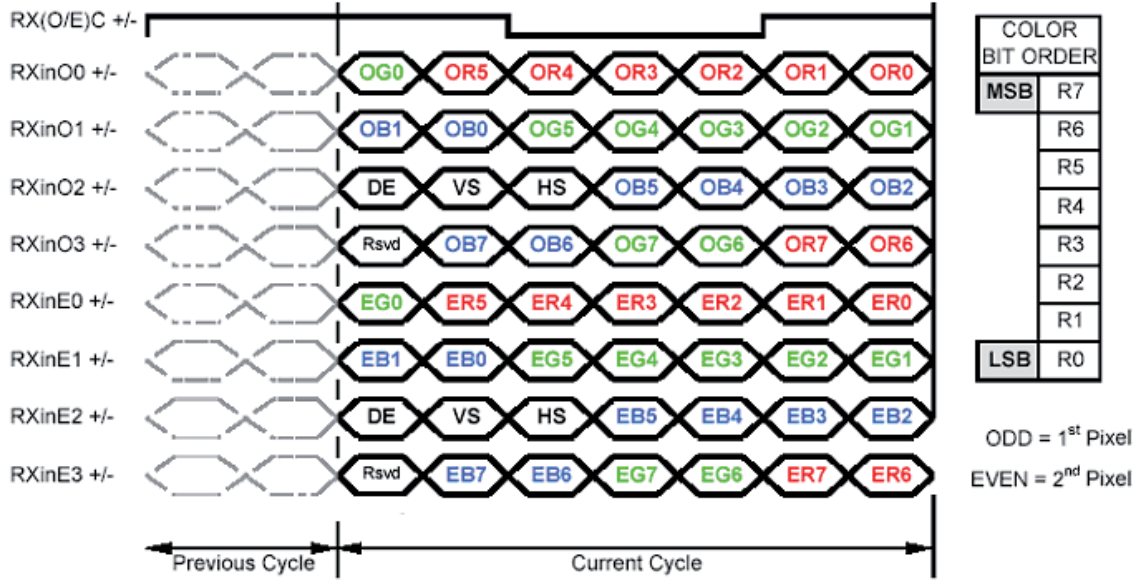

Product Specification

6.3 Signal Description

The module using one LVDS receiver SN75LVDS82(Texas Instruments). LVDS is a differential signal technology for LCD interface and high speed data transfer device. LVDS transmitters shall be SN75LVDS83(negative edge sampling). The first LVDS port(RxOxxx) transmits odd pixels while the second LVDS port(RxExxx) transmits even pixels.

Pin	Signal	Description
1	REIN3+	+ LVDS differential data input (Even CH3)
2	REIN3-	- LVDS differential data input (Even CH3)
3	RECLKIN+	+ LVDS differential data input (Even CLK)
4	RECLKIN-	- LVDS differential data input (Even CLK)
5	REIN2+	+ LVDS differential data input (Even CH2)
6	REIN2-	- LVDS differential data input (Even CH2)
7	GND	Ground
8	REIN1+	+ LVDS differential data input (Even CH1)
9	REIN1-	- LVDS differential data input (Even CH1)
10	GND	Ground
11	REIN0+	+ LVDS differential data input (Even CH0)
12	REIN0-	- LVDS differential data input (Even CH0)
13	ROIN3+	+ LVDS differential data input (Odd CH3)
14	ROIN3-	- LVDS differential data input (Odd CH3)
15	ROCLKIN+	+ LVDS differential data input (Odd CLK)
16	ROCLKIN-	- LVDS differential data input (Odd CLK)
17	GND	Ground
18	ROIN2+	+ LVDS differential data input (Odd CH2)
19	ROIN2-	- LVDS differential data input (Odd CH2)
20	ROIN1+	+ LVDS differential data input (Odd CH1)
21	ROIN1-	- LVDS differential data input (Odd CH1)
22	ROIN0+	+ LVDS differential data input (Odd CH0)
23	ROIN0-	- LVDS differential data input (Odd CH0)
24	GND	Ground
25	GND	Ground
26	GND	Ground
27	GND	Ground
28	VDD	+3.3V
29	VDD	+3.3V
30	VDD	+3.3V

Product Specification

6.4 Interface Timing (LVDS)

6.4.1 Timing Characteristics

Basically, interface timings should match the 1920x1080/ 60Hz manufacturing guide line timing.

Parameter	Symbol	Min.	Typ.	Max.	Unit	
Frame Rate	-	40	60	60	Hz	
Clock frequency	$1/T_{\text{Clock}}$	50	70.93	75	MHz	
Horizontal Section	Period	T_H	1050	1065	1075	T_{Clock}
	Active	T_{HD}	960			
	Blanking	T_{HB}	90	105	115	
Vertical Section	Period	T_V	1090	1110	1130	T_{line}
	Active	T_{VD}	1080			
	Blanking	T_{VB}	10	30	50	

Note 1: DE mode only.

6.4.2 Timing Diagram

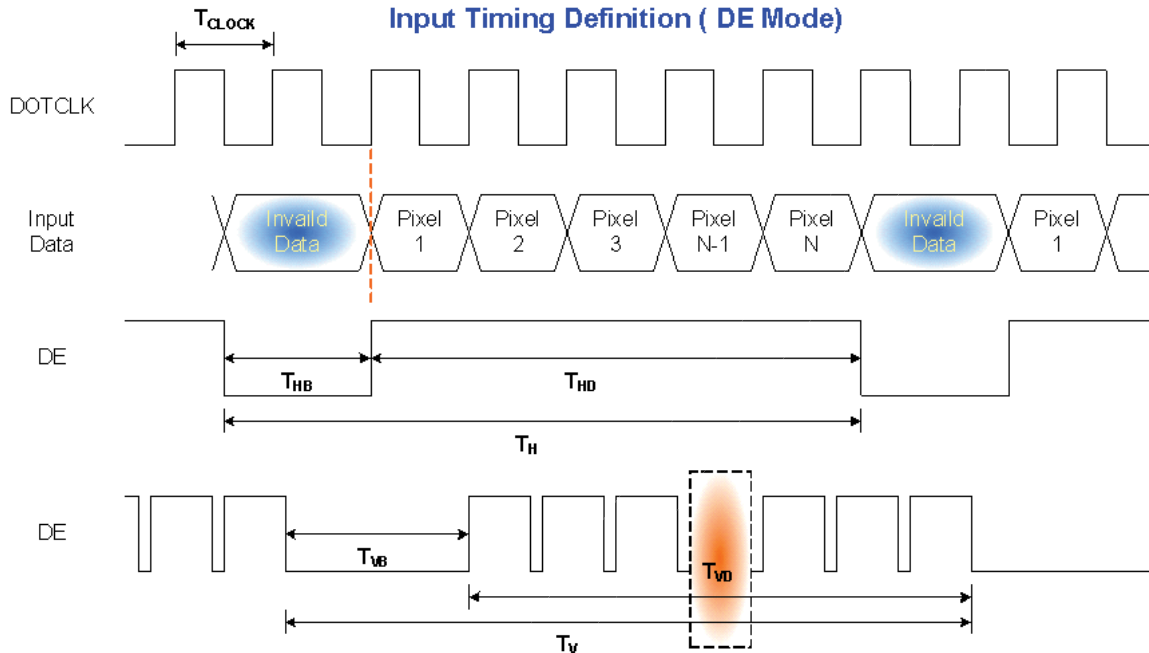

Product Specification

6.5 Power ON/OFF Sequence

LED on/off sequence is as follows. Interface signals are also shown in the chart.

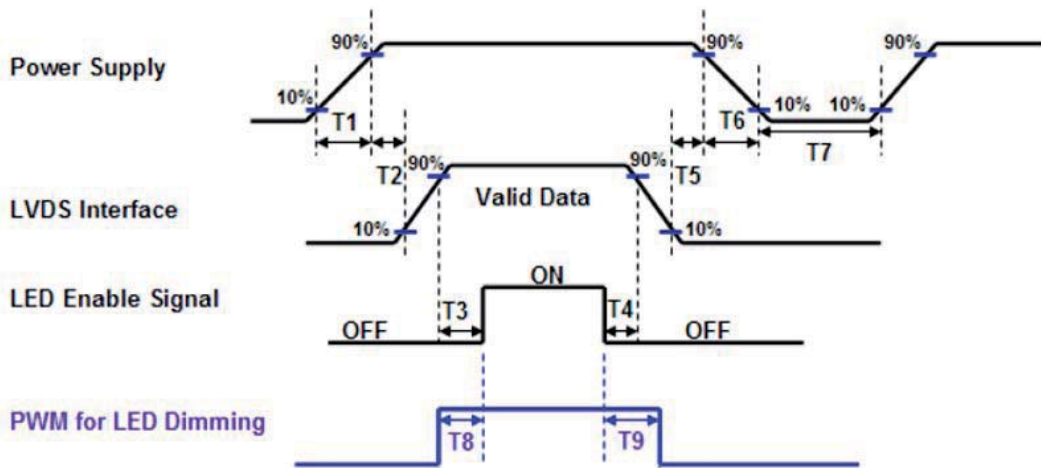

Power Sequence Timing			
Parameter	Value		Units
	Min.	Max.	
T1	0.5	10	ms
T2	60	70	
T3	400	-	
T4	400	-	
T5	0	50	
T6	0	10	
T7	500	-	
T8	10	180	
T9	10	180	

Note 1: If $T4 < 400\text{ms}$, The display garbage may occur. We suggest $T4 > 400\text{ms}$ to avoid the display garbage.

Note 2: If $T1 < 0.5\text{ms}$, the inrush current may cause the damage of fuse. If $T1 < 0.5\text{ms}$, the inrush current I_{2t} is under typical melt of fuse Spec., there is no mentioned problem.

Product Specification

7. Connector & Pin Assignment

Physical interface is described as for the connector on module. These connectors are capable of accommodating the following signals and will be following components.

7.1 TFT LCD Module

Connector Name / Designation	Interface Connector / Interface card
Manufacturer	HRS
Type Part Number	DF14H-30P-1.25H
Mating Housing Part Number	DF14H-30S-1.25C

7.1.1 Pin Assignment

Pin#	Signal Name	Pin#	Signal Name
1	REIN3+	2	REIN3-
3	RECLKIN+	4	RECLKIN-
5	REIN2+	6	REIN2-
7	GND	8	REIN1+
9	REIN1-	10	GND
11	REIN0+	12	REIN0-
13	ROIN3+	14	ROIN3-
15	ROCLKIN+	16	ROCLKIN-
17	GND	18	ROIN2+
19	ROIN2-	20	ROIN1+
21	ROIN1-	22	ROIN0+
23	ROIN0-	24	GND
25	GND	26	GND
27	GND	28	VDD
29	VDD	30	VDD

7.2 Backlight Unit

Physical interface is described as for the connector on module. These connectors are capable of accommodating the following signals and will be following components.

Connector Name / Designation	LED Connector
Manufacturer	E&T
Type Part Number	3710K-Q10N-01R
Mating Housing Part Number	H113K-D10N-01B

Product Specification

7.2.1 LED Driver Connector Pin Assignment

Pin#	Symbol	Signal Name
1	VCC	+12V
2	VCC	+12V
3	VCC	+12V
4	VCC	+12V
5	GND	Ground
6	GND	Ground
7	GND	Ground
8	GND	Ground
9	ENABLE	LED enable pin
10	PWM	System PWM Single Input

Note1: Start from right side

Note2: Connector Illustration

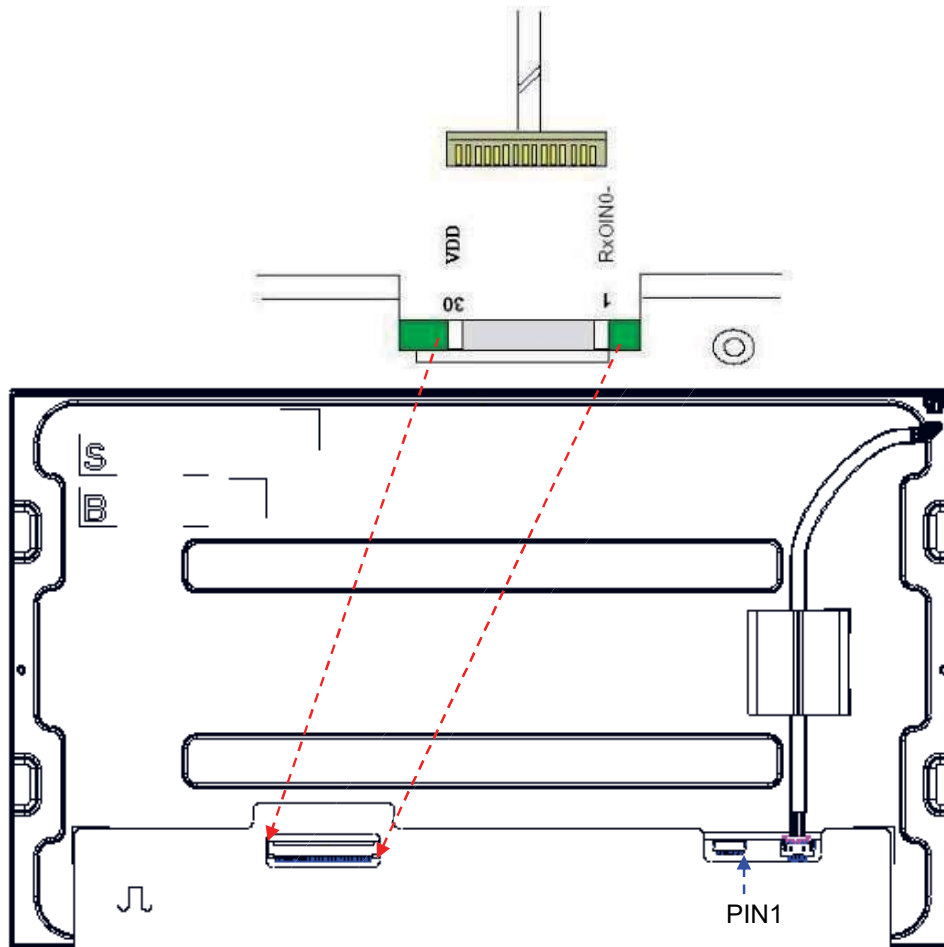

Product Specification

8. Panel Reliability Test

8.1 Vibration Test

Test Spec:

- Test method: Non-Operation
- Acceleration: 1.5 G
- Frequency: 10 - 500Hz Random
- Sweep: 30 Minutes each Axis (X, Y, Z)

8.2 Shock Test

Test Spec:

- Test method: Non-Operation
- Acceleration: 220 G , Half sine wave
- Active time: 2 ms
- Pulse: X,Y,Z one time for each side

8.3 Reliability Test

Items	Required Condition	Note
Temperature Humidity Bias	Ta= 40°C, 90%RH, 300h	Note 1,2
High Temperature Operation	Ta= 70°C , Dry, 300h	
Low Temperature Operation	Ta= -10°C, 300h	
High Temperature Storage	Ta= 70°C, Dry, 300h	
Low Temperature Storage	Ta= -20°C, 300h	
Thermal Shock Test	Ta=-20°C to 60°C, Duration at 30 min, 100 cycles	
ESD	Contact : ±8 KV (TBD) Air : ±15 KV (TBD)	Note 1

Note 1: According to EN 61000-4-2 , ESD class B: Some performance degradation allowed.
Self-recoverable. No data lost, No hardware failures.

Note 2:

- Water condensation is not allowed for each test items.
- Each test is done by new TFT-LCD module. Don't use the same TFT-LCD module repeatedly for reliability test.
- The reliability test is performed only to examine the TFT-LCD module capability.
- To inspect TFT-LCD module after reliability test, please store it at room temperature and room humidity for 24 hours at least in advance.
- No function failure occurs. Muir shall be ignored after high temperature reliability test

Product Specification

9. Shipping and Package

9.1 Shipping Label Format



Note 1: For Pb Free products, AUO will add  for identification.

Note 2: For RoHS compatible products, AUO will add  for identification.

Note 3: For China RoHS compatible products, AUO will add  for identification.

Note 4: The Green Mark will be presented only when the green documents have been ready by AUO Internal Green Team.

9.2 Carton Package

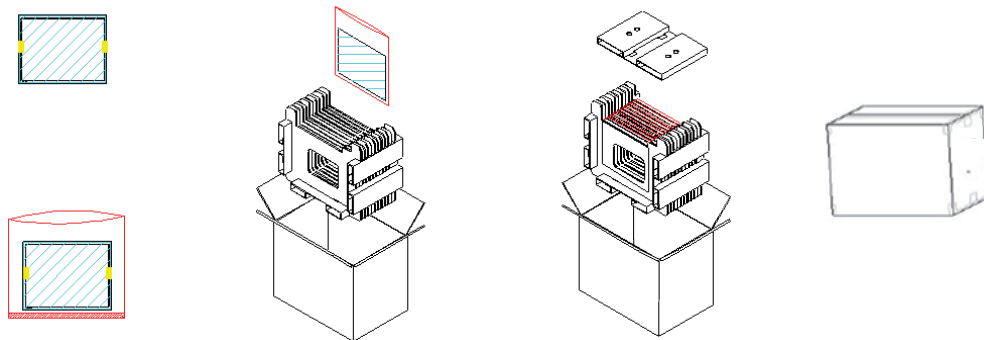

Max capacity : 16 TFT-LCD module per carton

Max weight: 16.3 kg per carton

Outside dimension of carton: 450mm(L)*375mm(W)*319mm(H)

Pallet size : 1150 mm * 910 mm * 132mm

Product Specification

Box stacked

Module by air : (2 *3) *4 layers , one pallet put 24 boxes , total 384pcs module

Module by sea : (2 *3) *4 layers+(2 *3) *1 layers , two pallet put 30 boxes , total 480pcs module

Module by sea_HQ : (2 *3) *4 layers+(2 *3) *2 layers , two pallet put 42 boxes , total 576 pcs module

9.3 Shipping Package of Palletizing Sequence

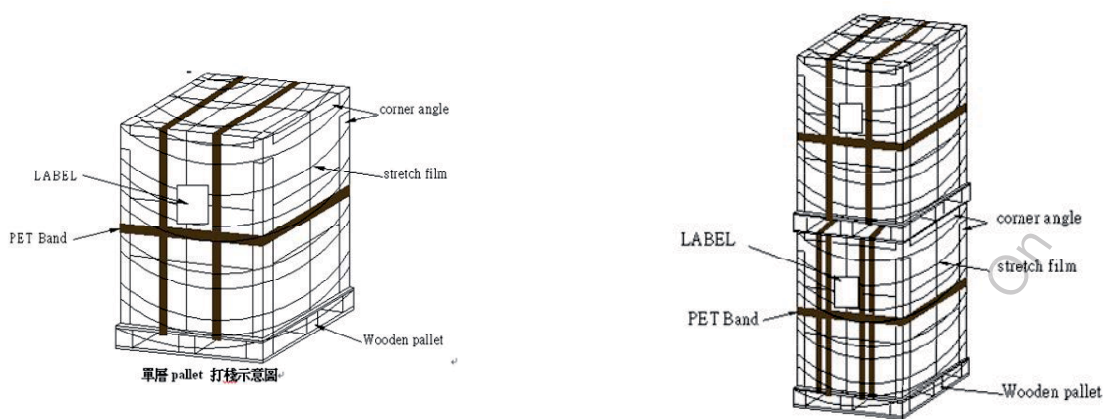

Product Specification

Product Specification

10 .Mechanical Characteristics

10.1 LCM Outline Dimension (Front View)

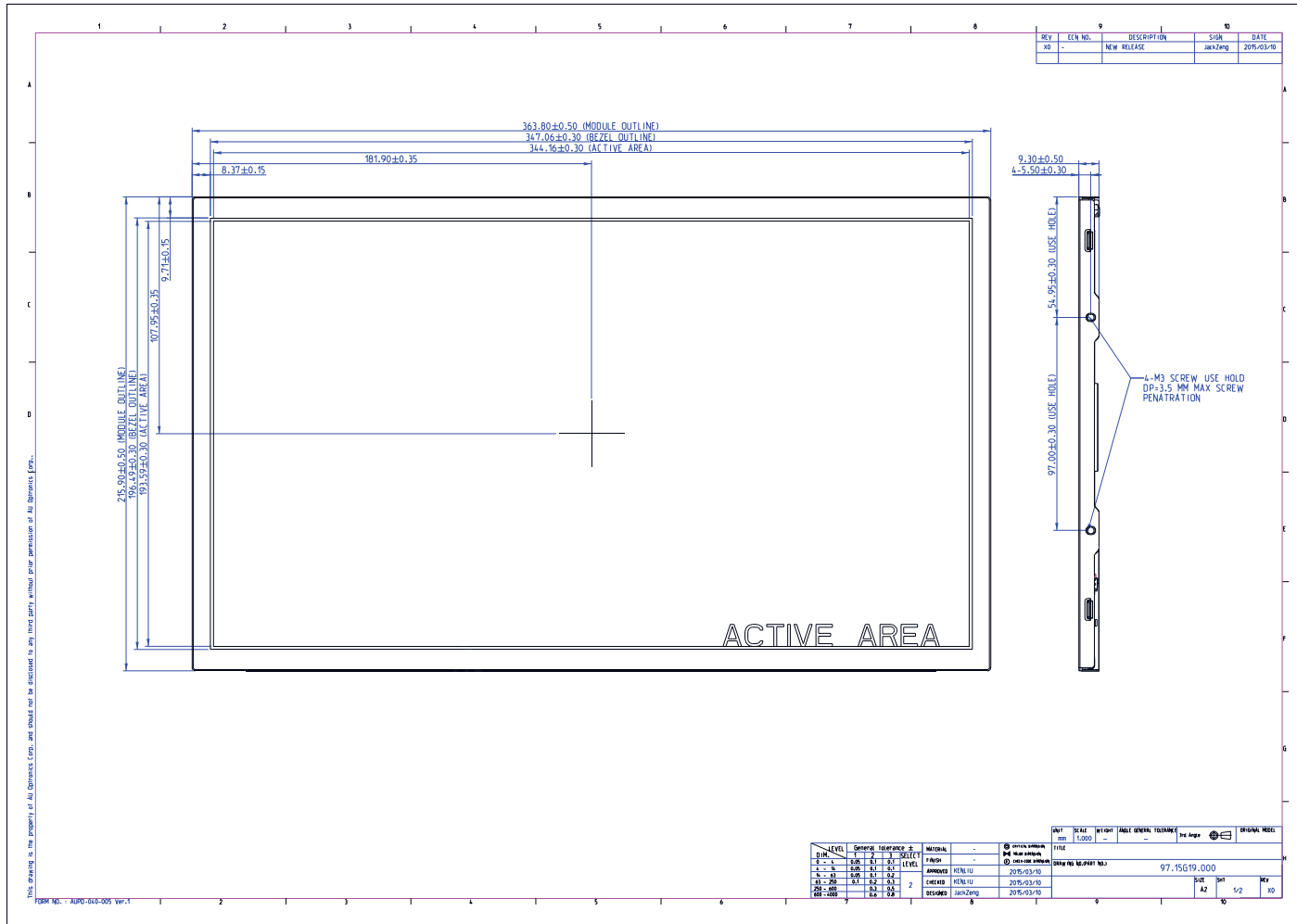

Product Specification

10.2 LCM Outline Dimension (Rear View)

