

Attachement Template AeroEndurance

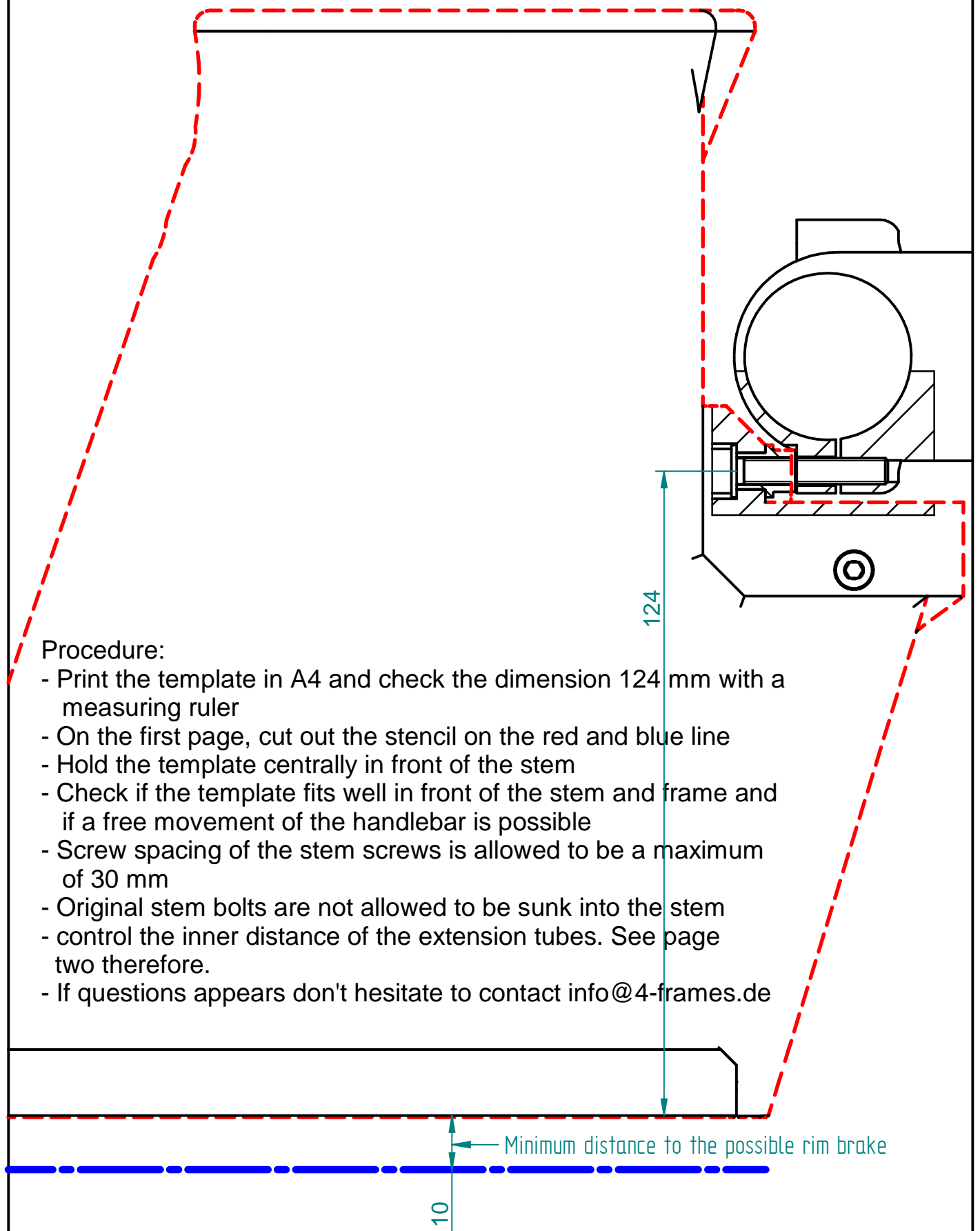

Procedure:

- Print the template in A4 and check the dimension 124 mm with a measuring ruler
- On the first page, cut out the stencil on the red and blue line
- Hold the template centrally in front of the stem
- Check if the template fits well in front of the stem and frame and if a free movement of the handlebar is possible
- Screw spacing of the stem screws is allowed to be a maximum of 30 mm
- Original stem bolts are not allowed to be sunk into the stem
- control the inner distance of the extension tubes. See page two therefore.
- If questions appears don't hesitate to contact info@4-frames.de

Attachement Template AeroEndurance

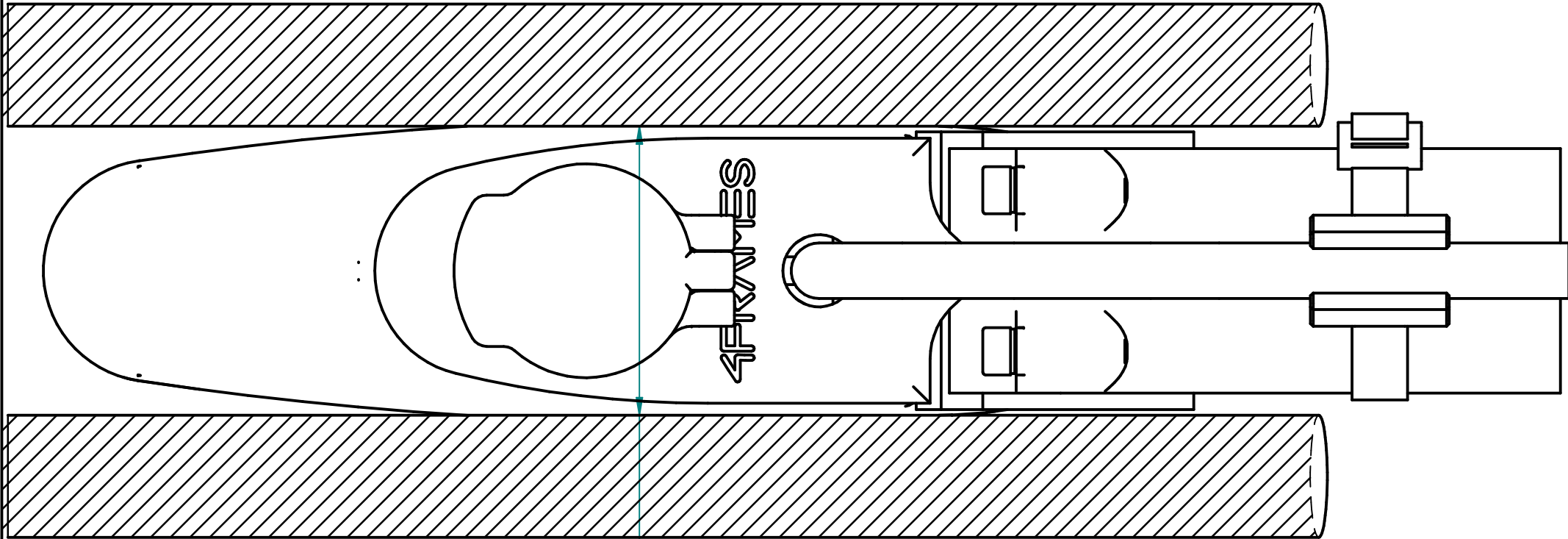

Minimum inner distance between the extension bars

52

Attachement Template AeroEndurance

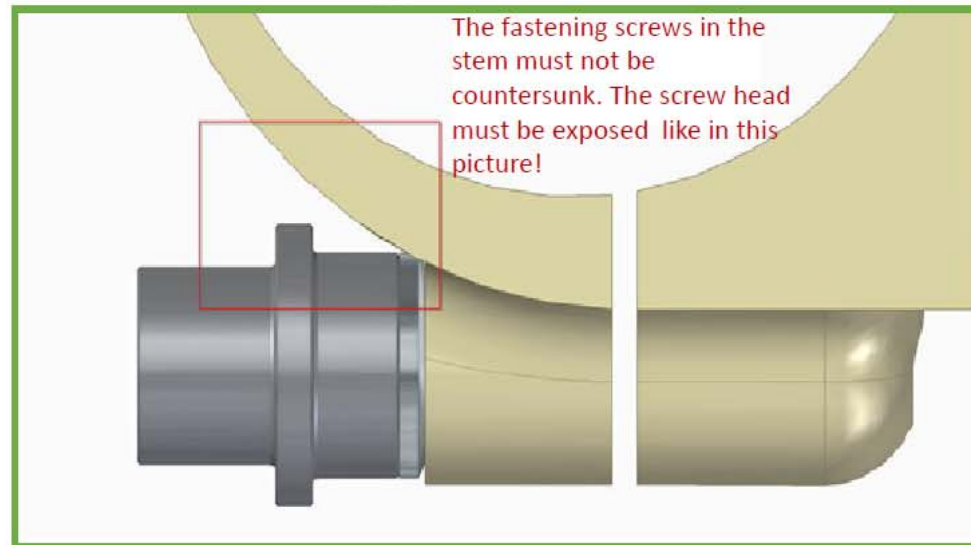
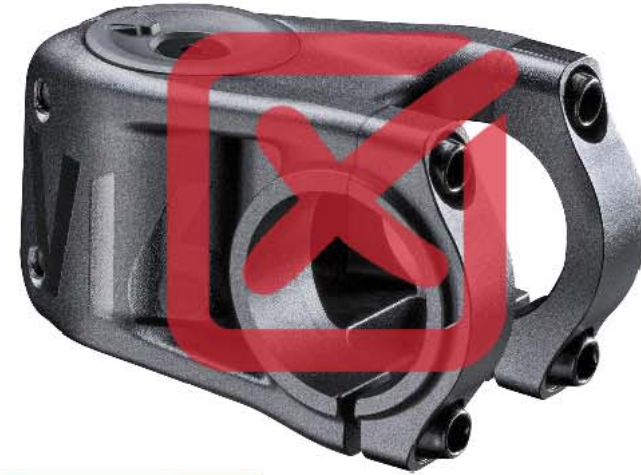

4 Frames