

Dannysound – EN129 Thru Zero Oscillator

Build Guide (v2.1)

Contents

Section 1 - Main PCB

Resistors

Diodes

Inductors

IC Sockets

Capacitors

Transistors

Power Socket

Trim Pots

Electrolytic Capacitors

Board Connector

Section 2 – Power Test, Matched Transistors and IC placement

Section 3 – Pots PCB

Resistors

IC Sockets

Capacitors

Transistors

Panel Components

Calibration

The EN129 is based on the pioneering work by Douglas Kraul and Bernie Hutchins. You can read the original Electronotes article from 1981 that the design is based upon [here](#)

This build guide is for all kits and panel/pcb sets purchased from September 2020 and onwards.

The PCB bag label should say 'V2.0' and on the front PCB it should be written 'V2.0' as circled below

If you're PCB reads v1.0 then please refer to build guide V1.05 and BOM v1.0

https://www.thonk.co.uk/documents/dannysound/EN129_ThruZero/



Section 1 - Main PCB

Resistors

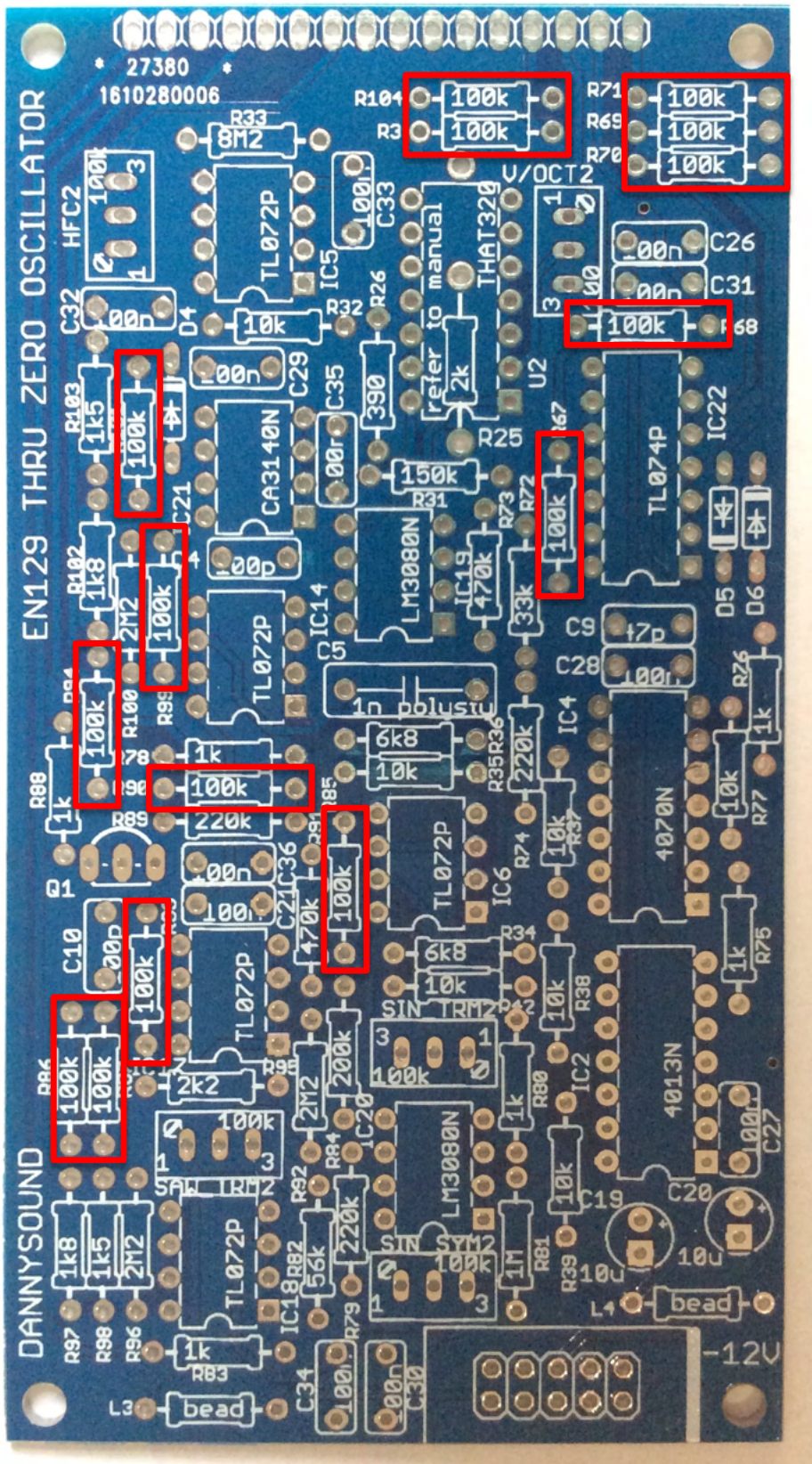

1 – 15 x 100k resistors

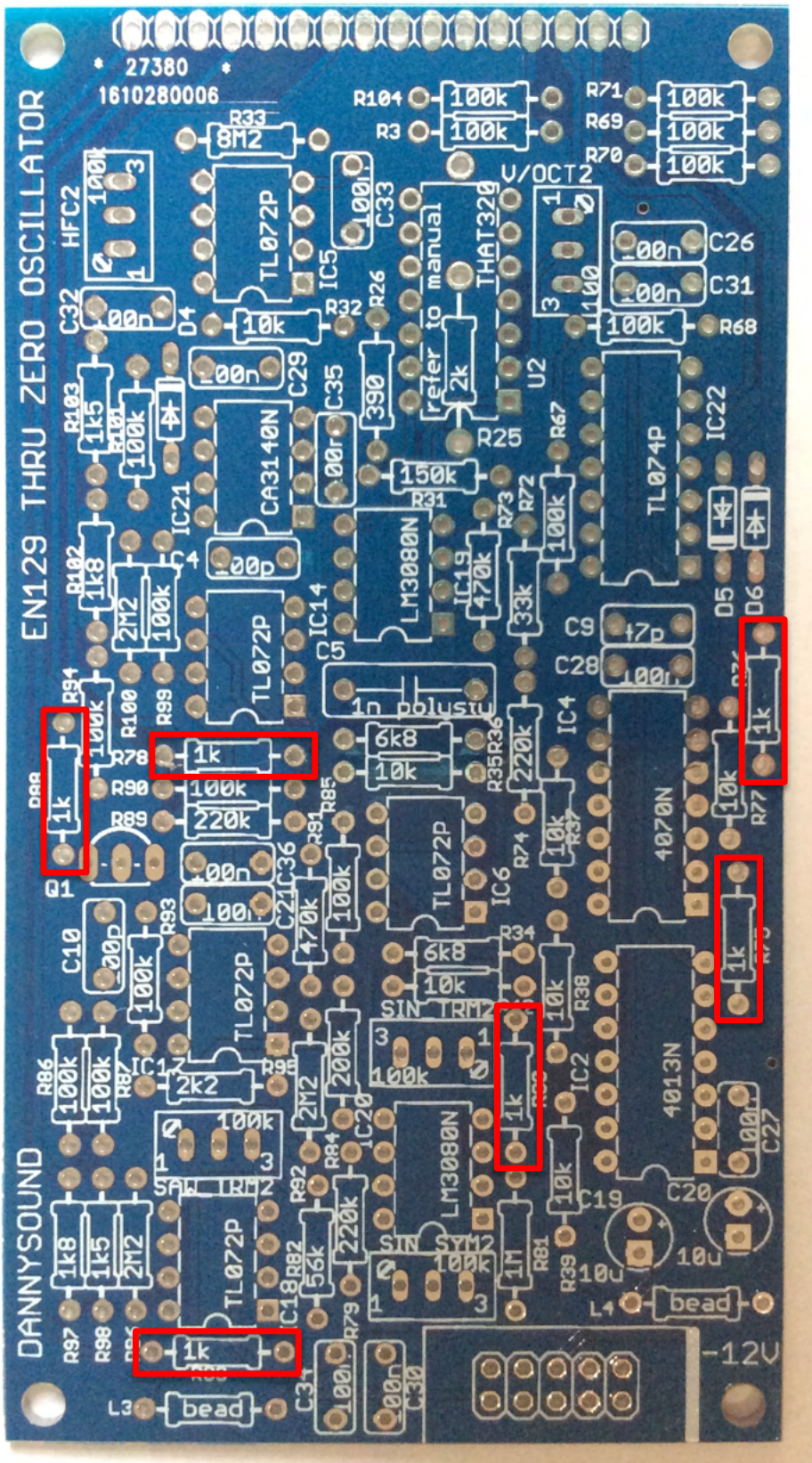

3 – 6 x 1k resistors

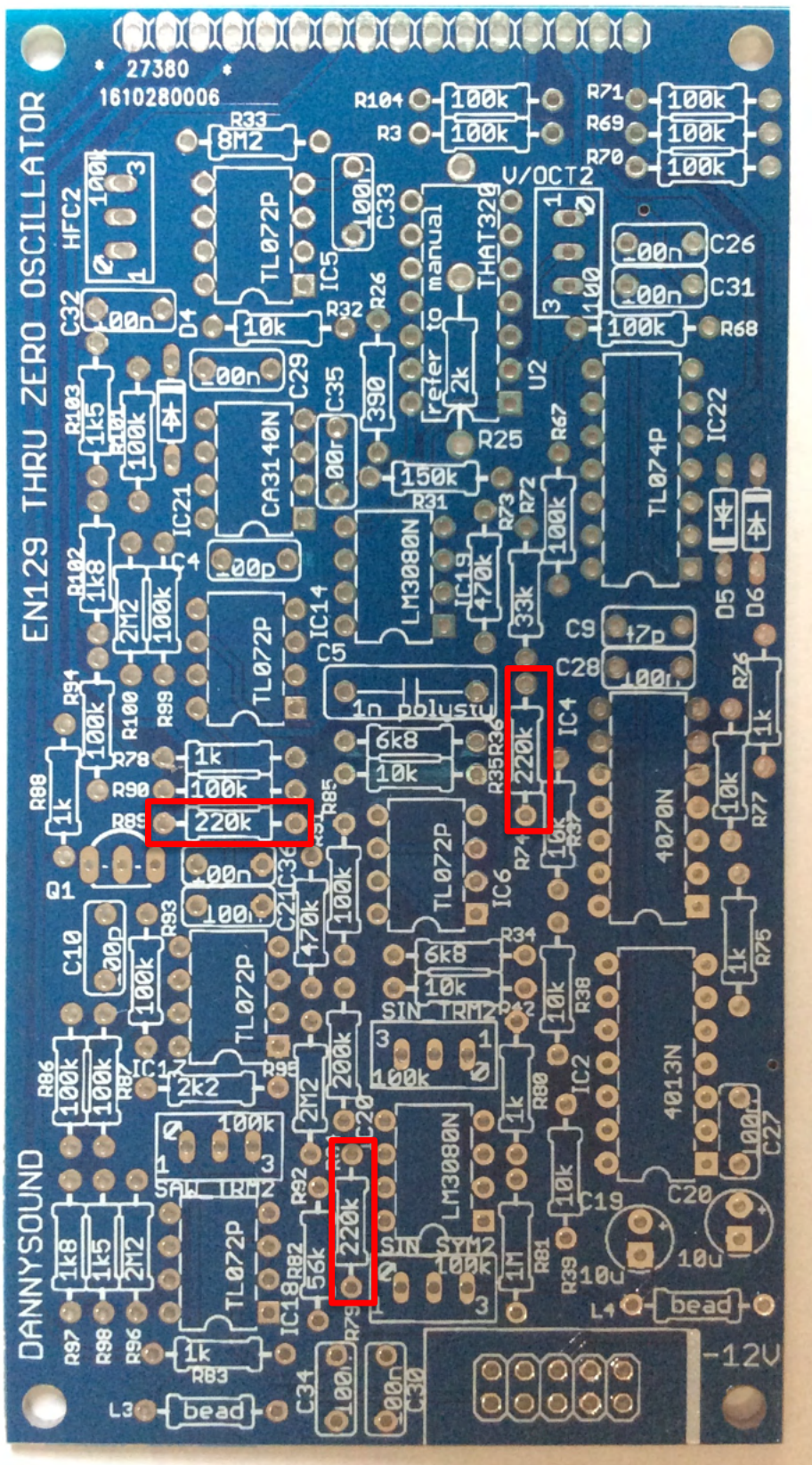

4 – 3 x 220k resistors

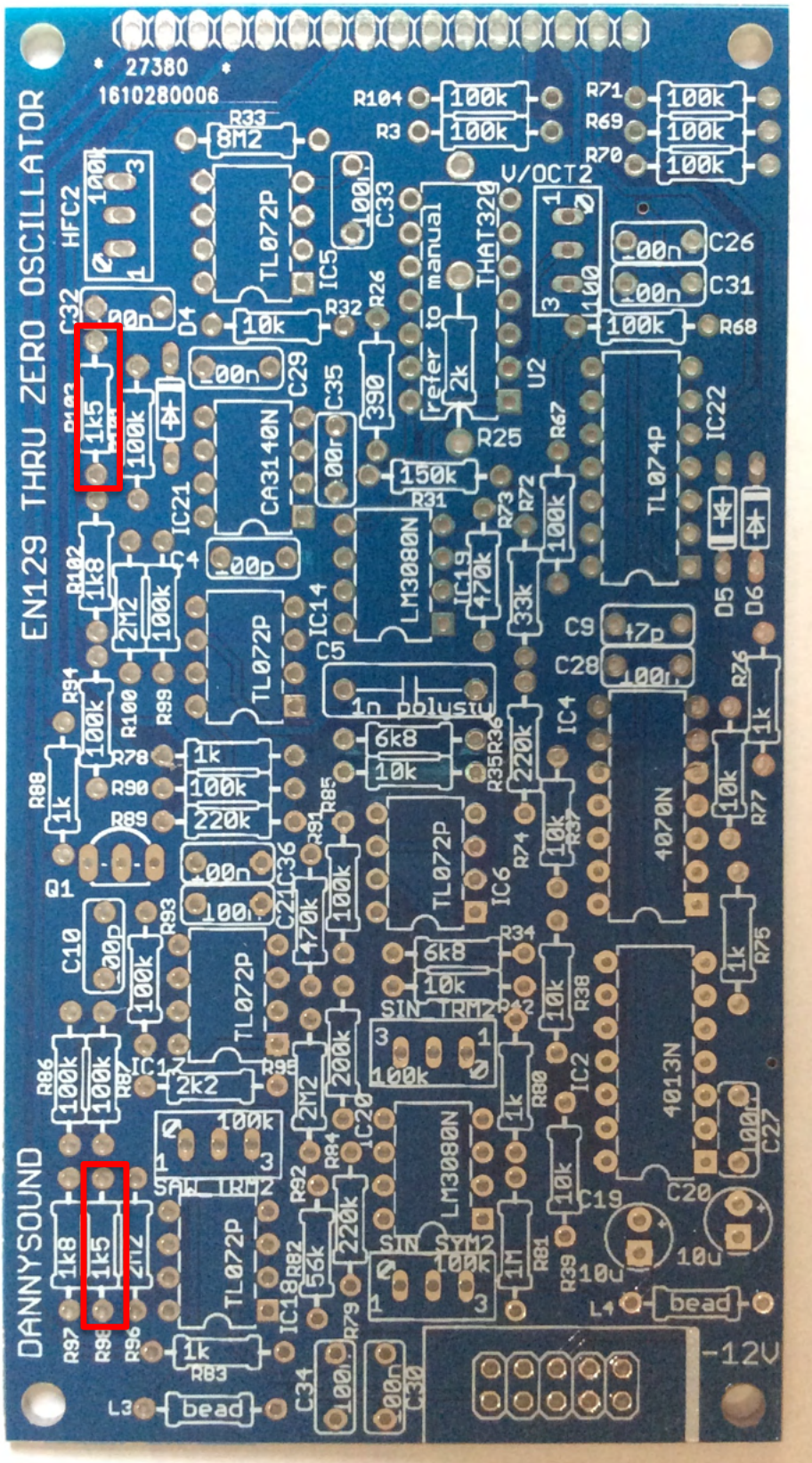

6 – 2 x 1k5 resistors

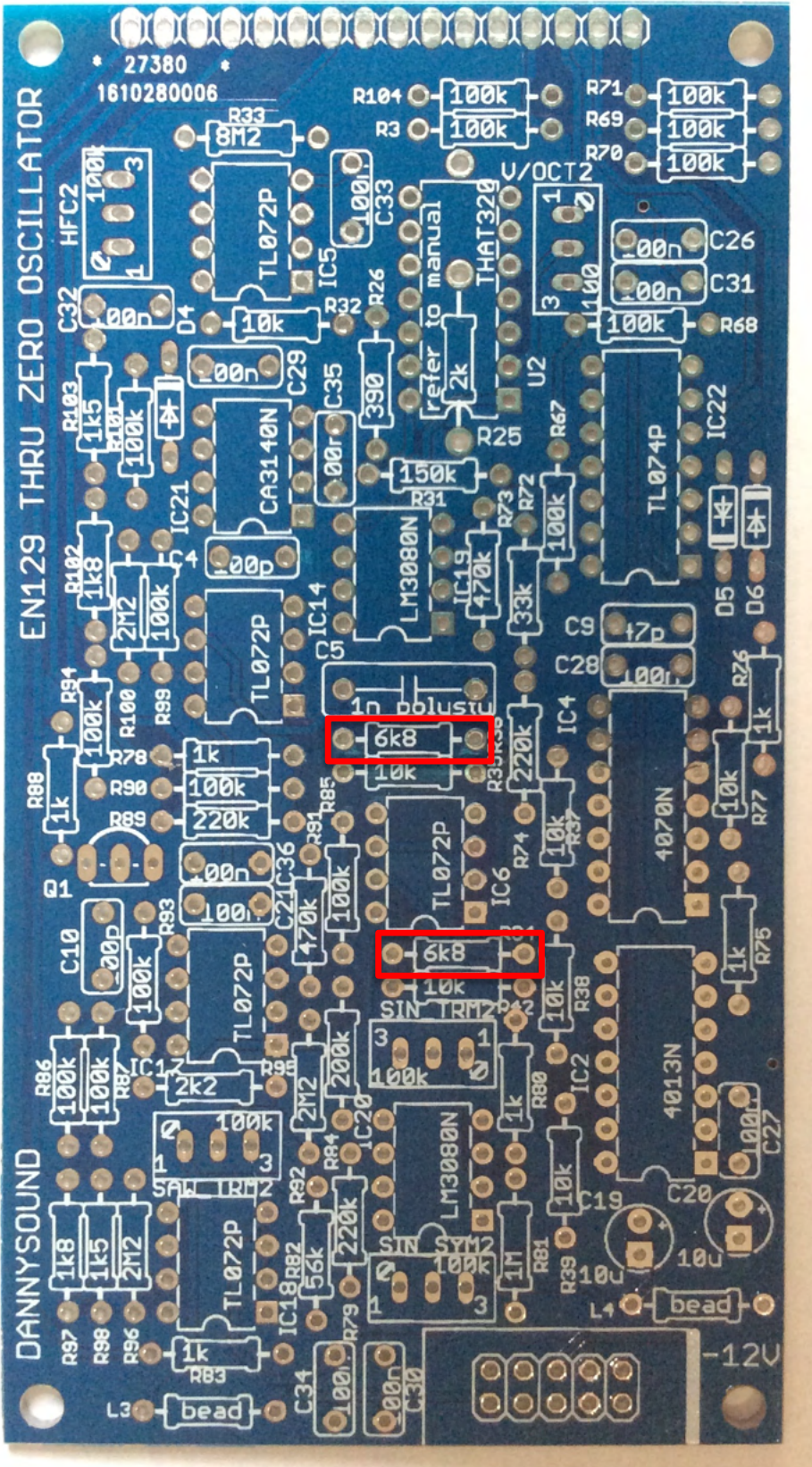

8 – 2 x 6k8 resistors

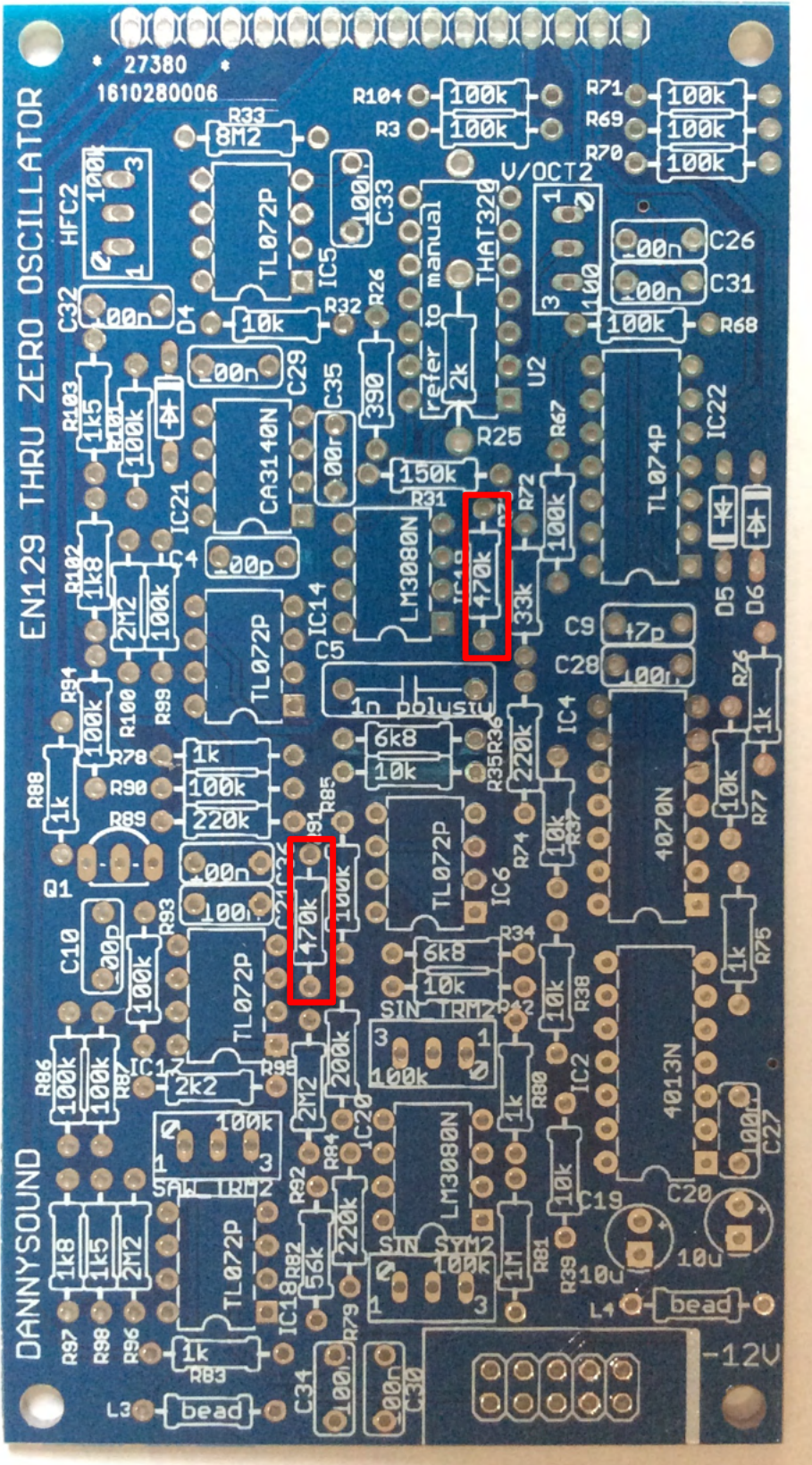

9 – 2 x 470k resistors

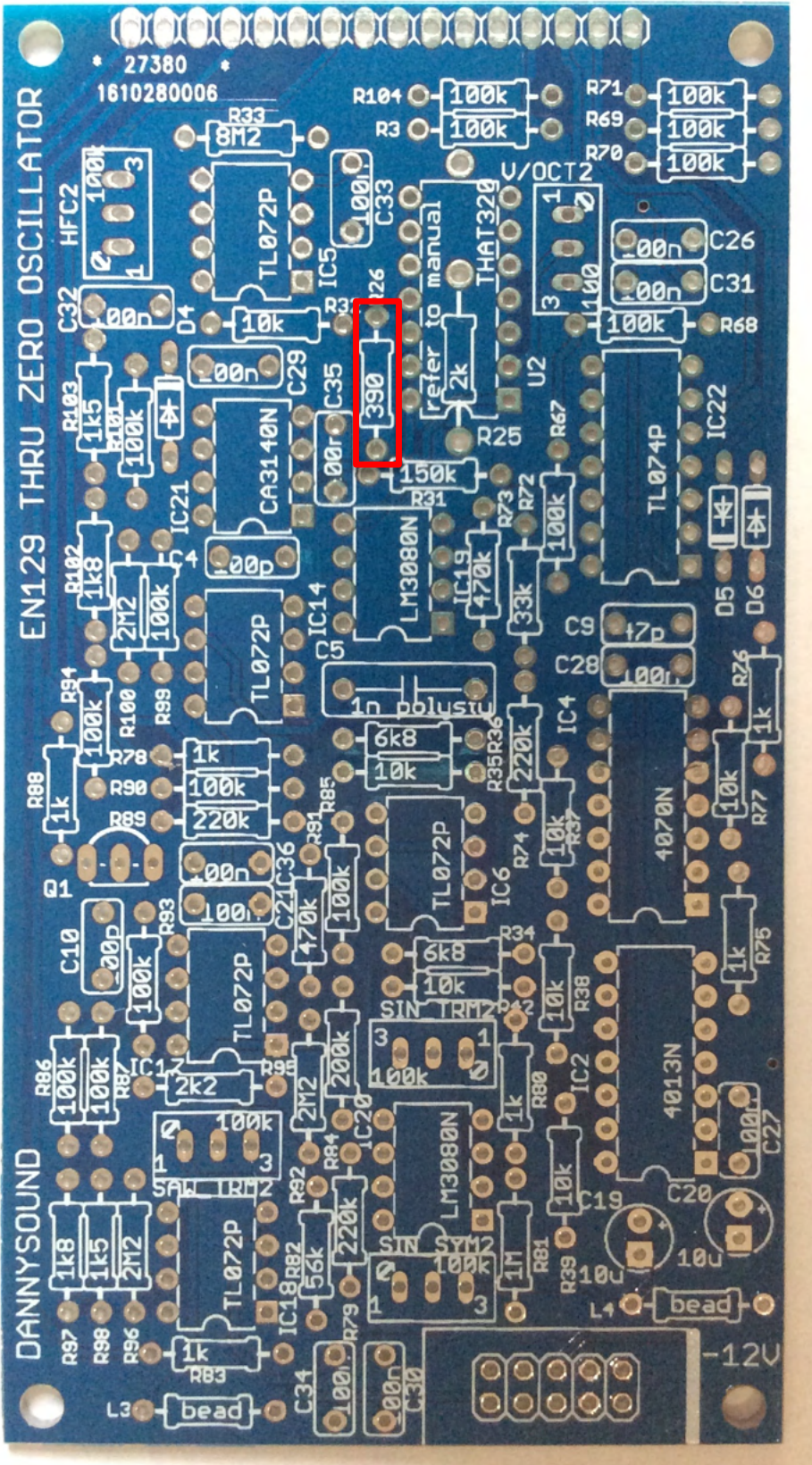

10 – 1 x 390r resistors

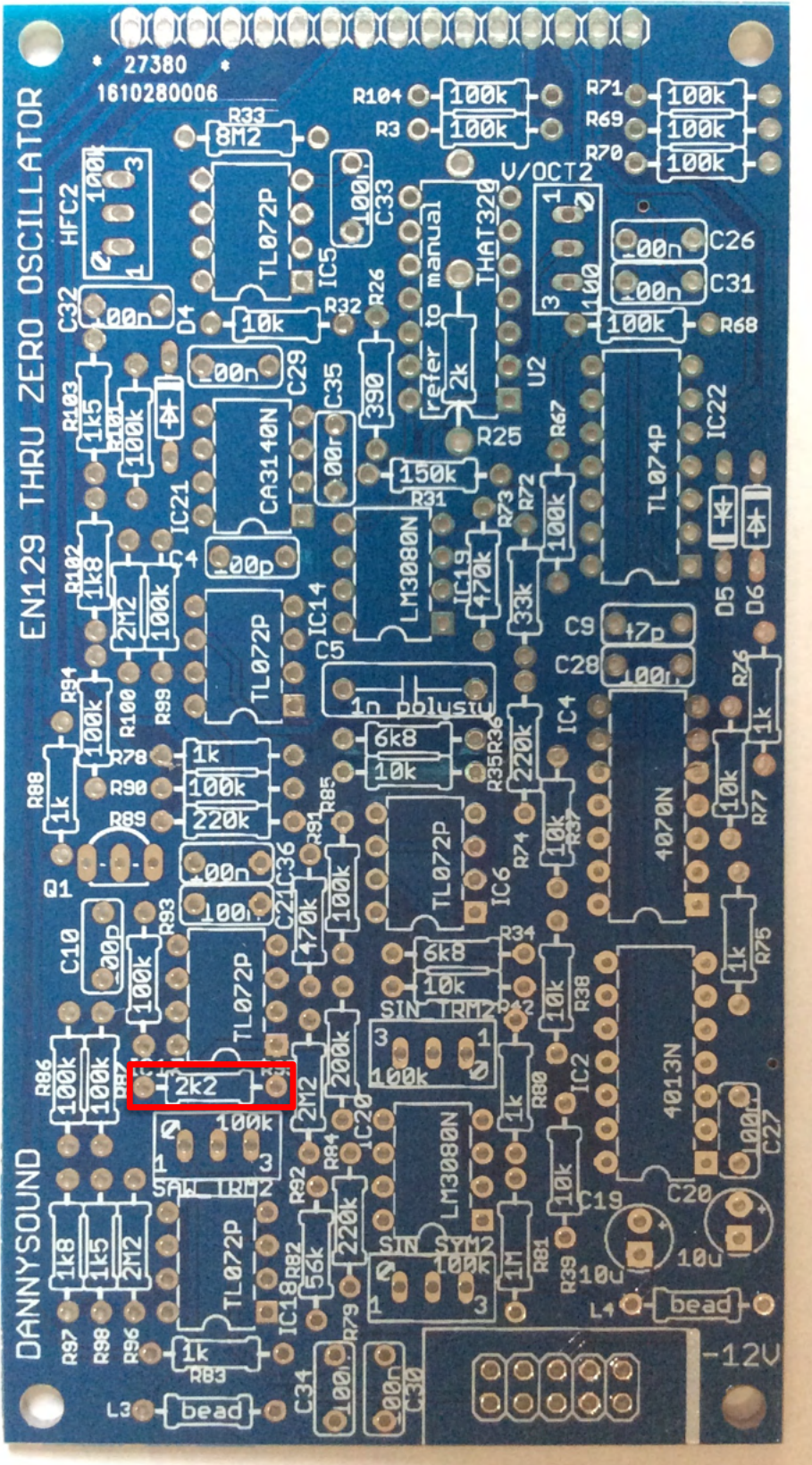

11 – 1 x 2k2 resistors

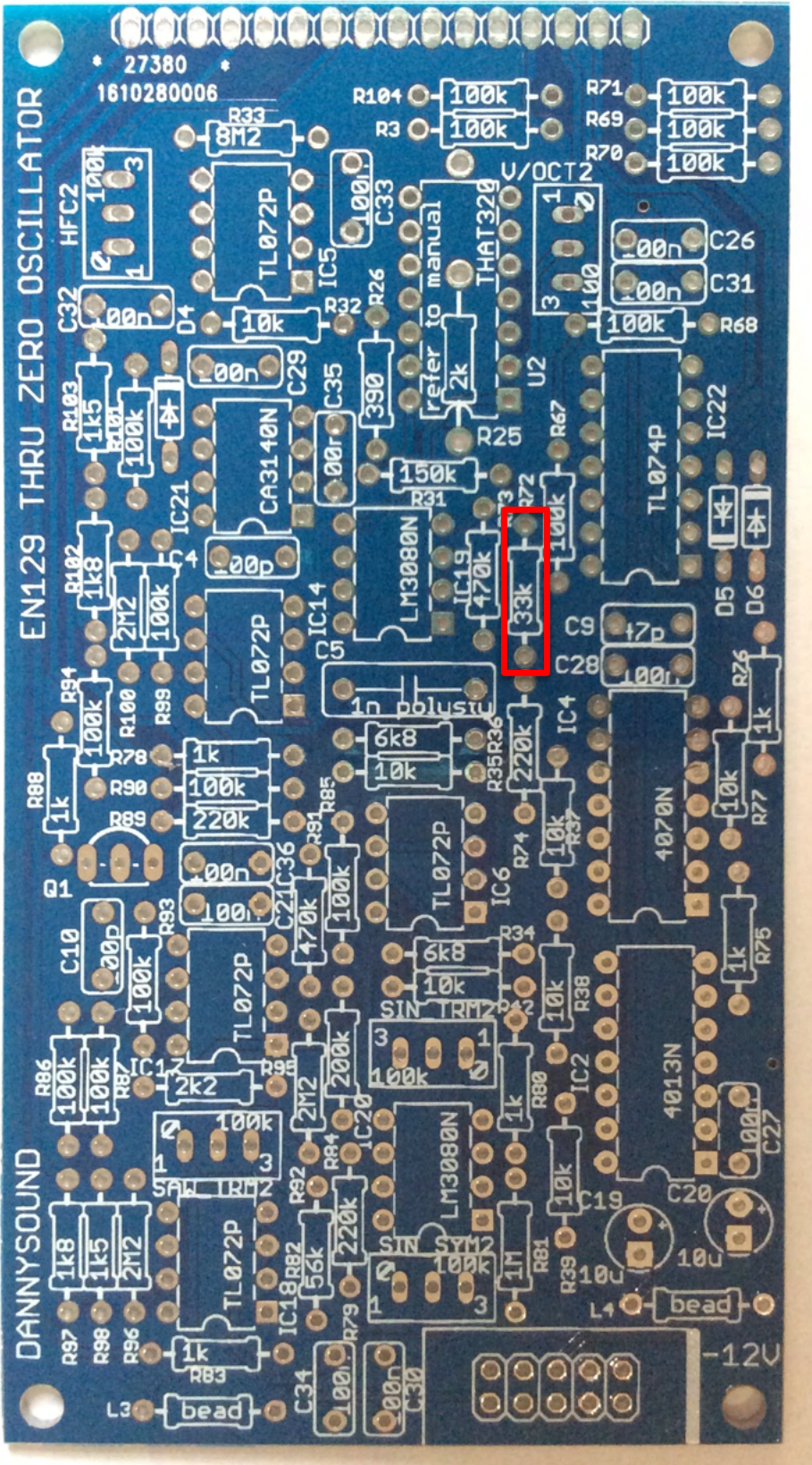

12 – 1 x 33k resistors

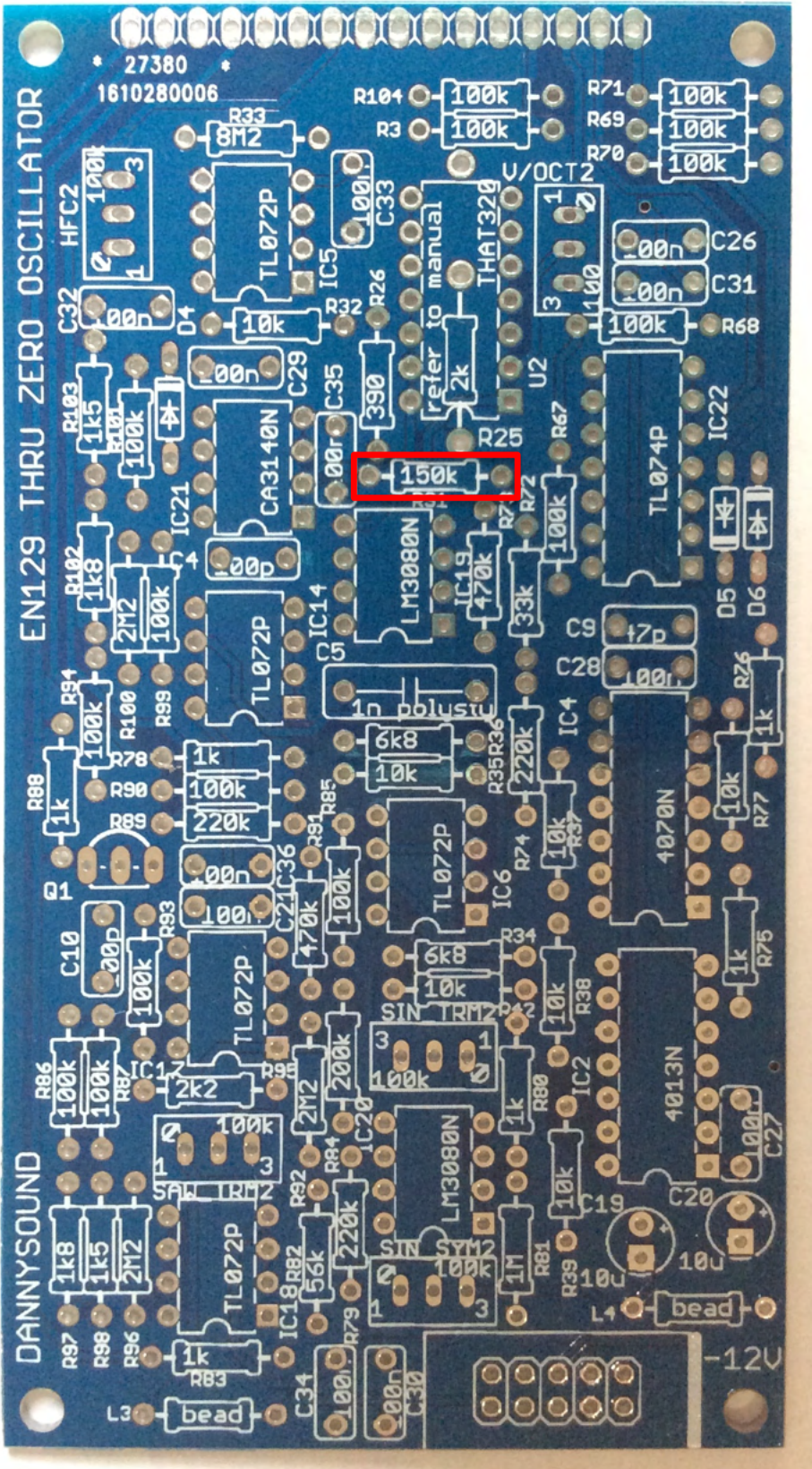

13 – 1 x 150k resistors

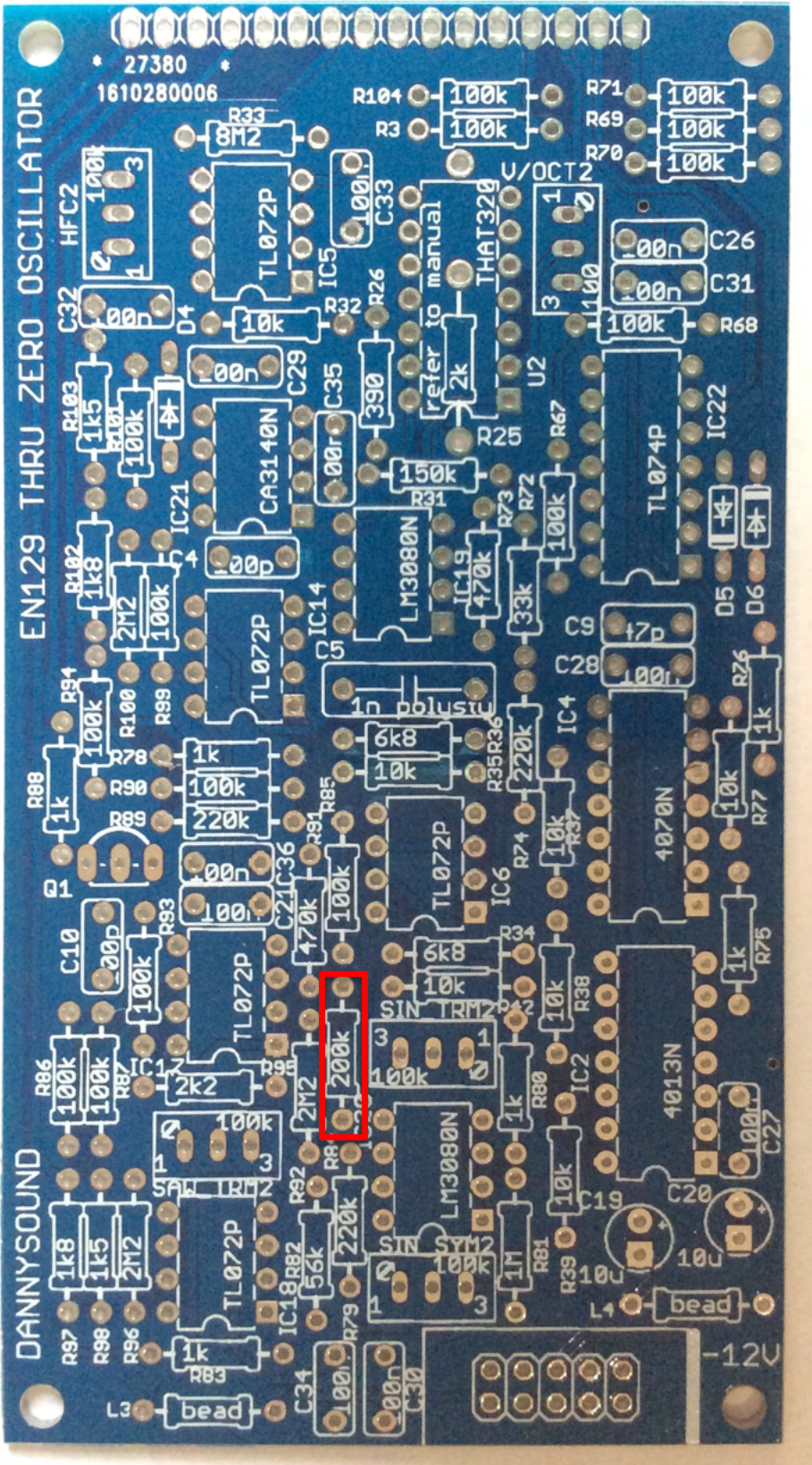

14 – 1 x 200k resistors

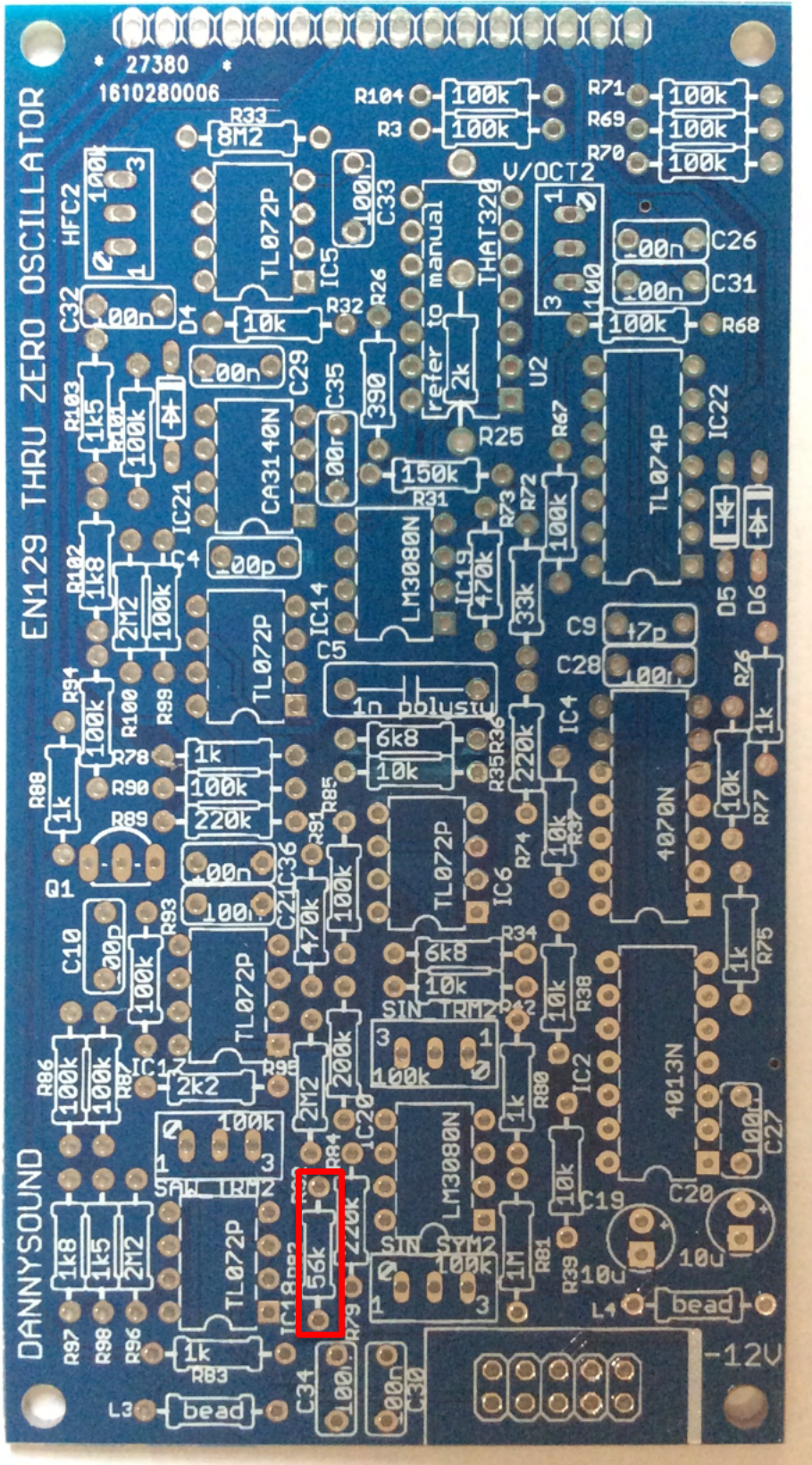

15 – 1 x 56k resistors

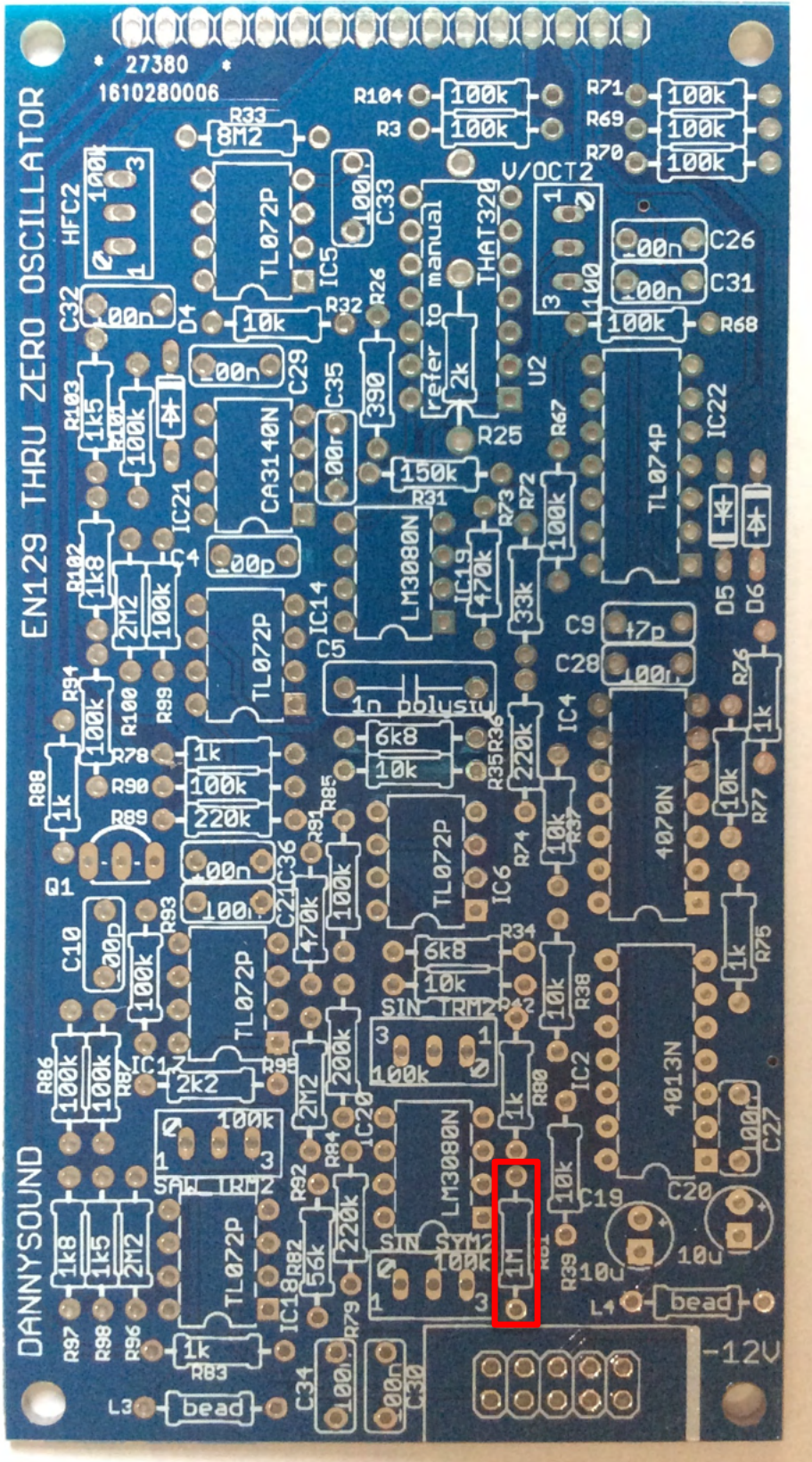

16 – 1 x 1M resistors

Diodes

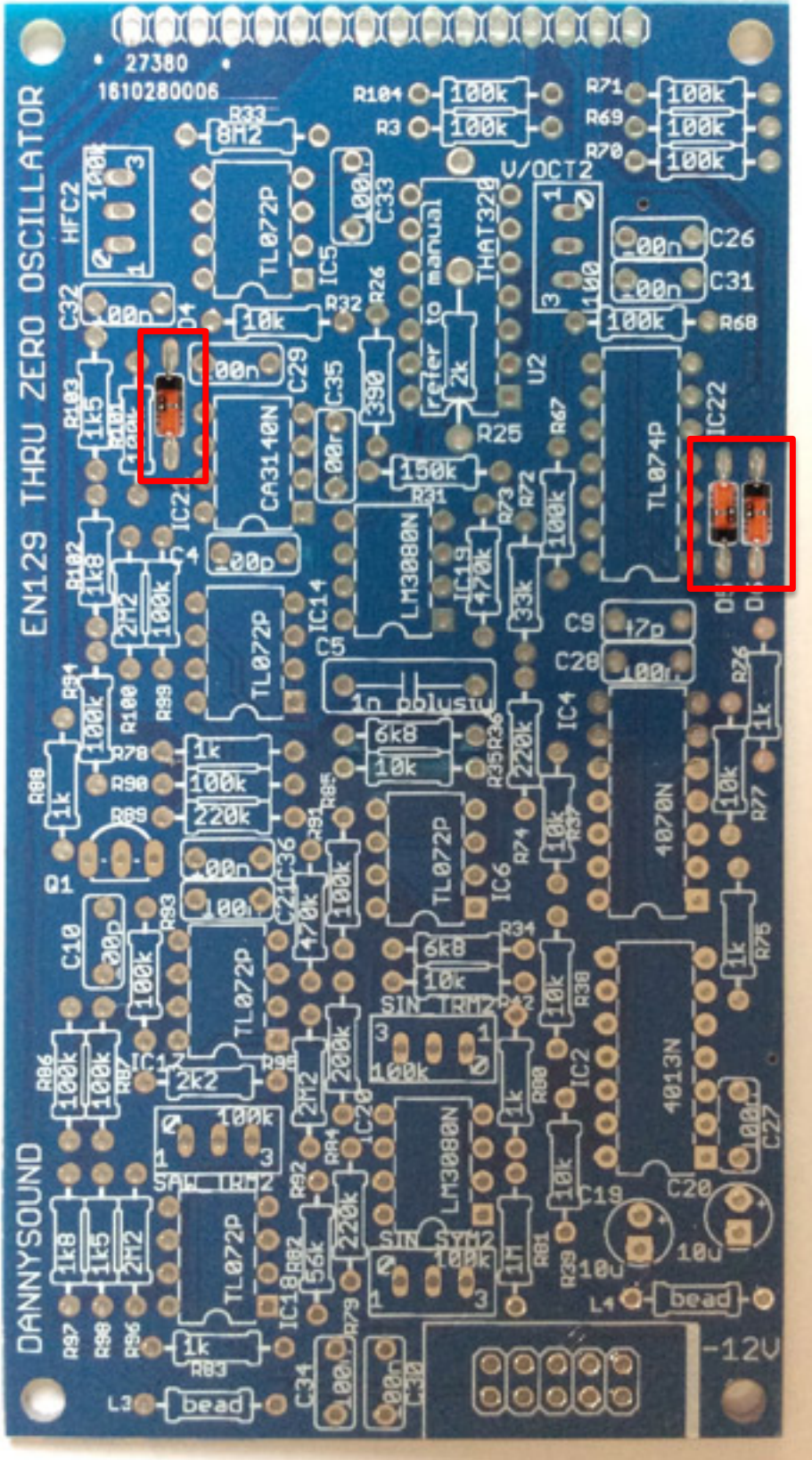

18 – 3 x 1N4148 diodes – Note: orientation of this part is vital, be sure to match the line on the component with that on the PCB silkscreen

Inductors

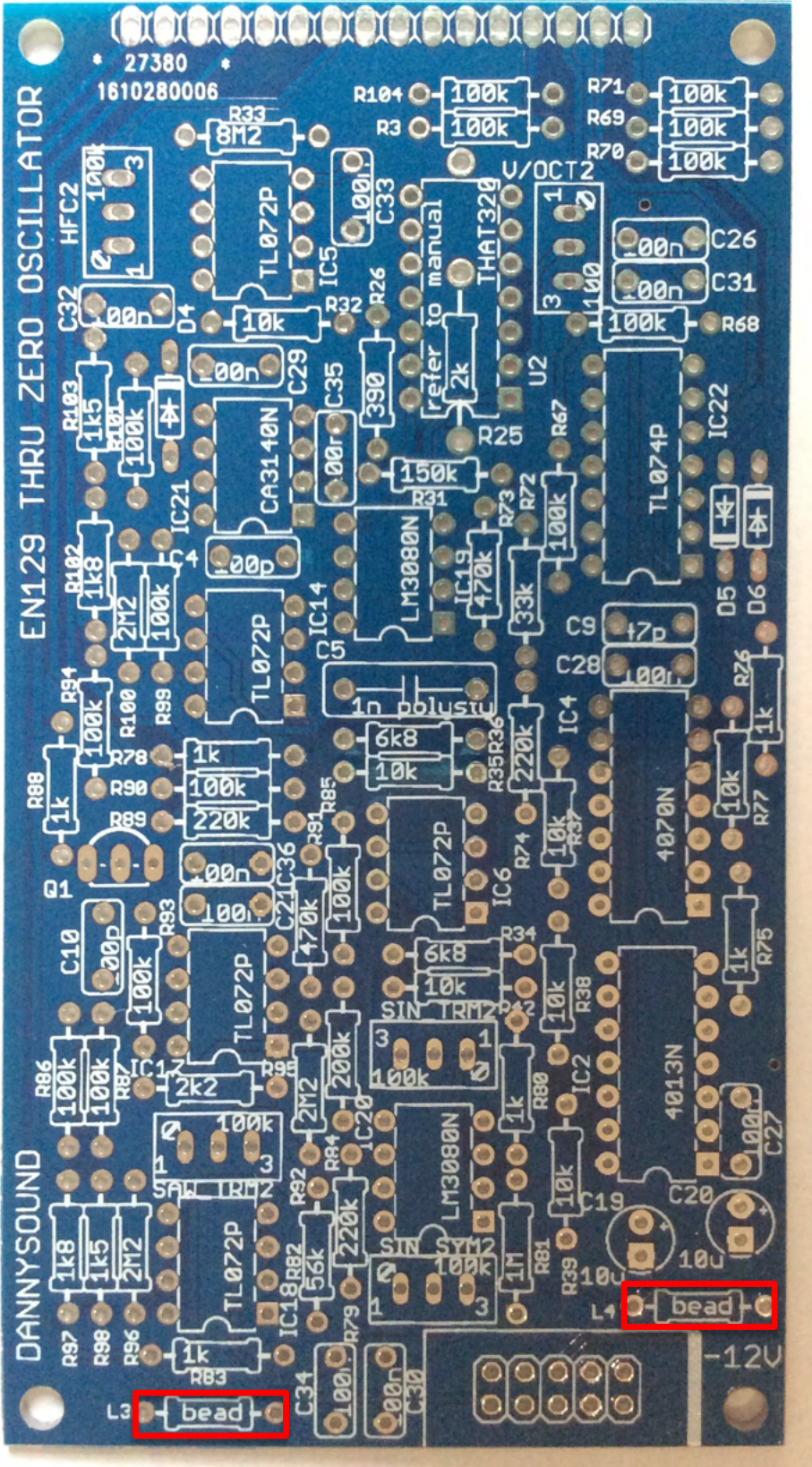

19 – 2 x bead inductors

IC Sockets

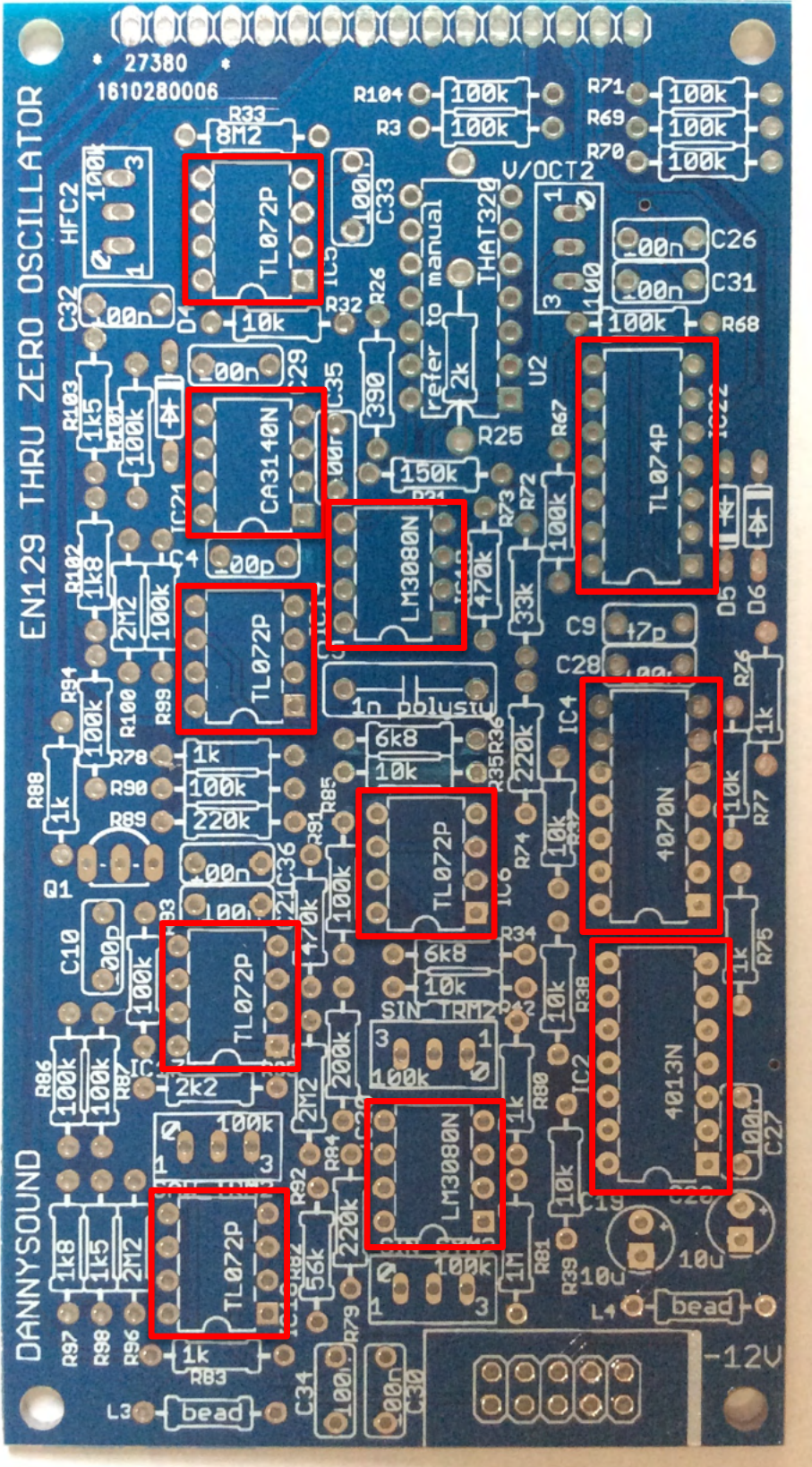

20 – IC sockets – Make sure the notches in the sockets match the notches on the silkscreen.

Capacitors

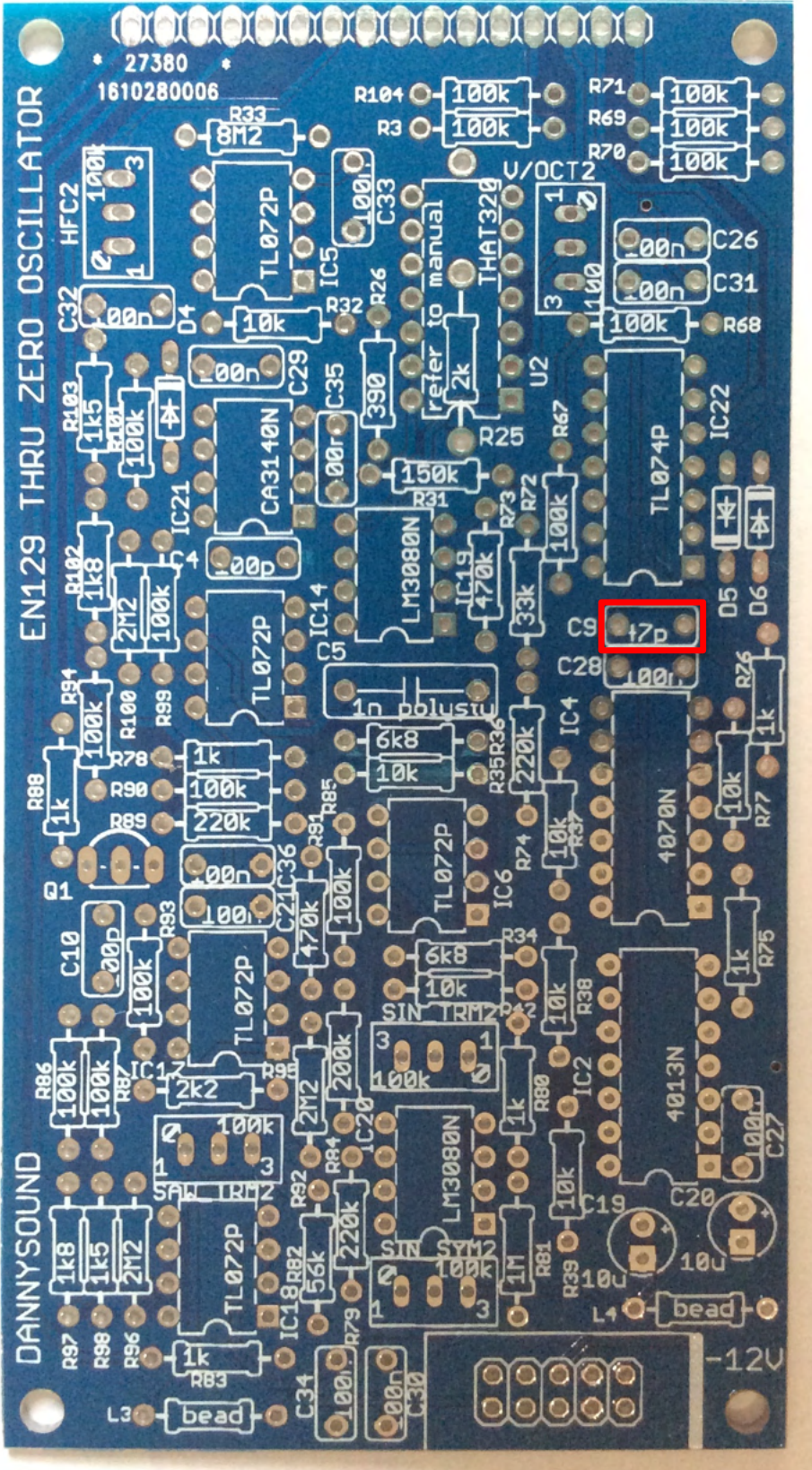

21 – 1 x 47pF capacitor (located in diode bag)

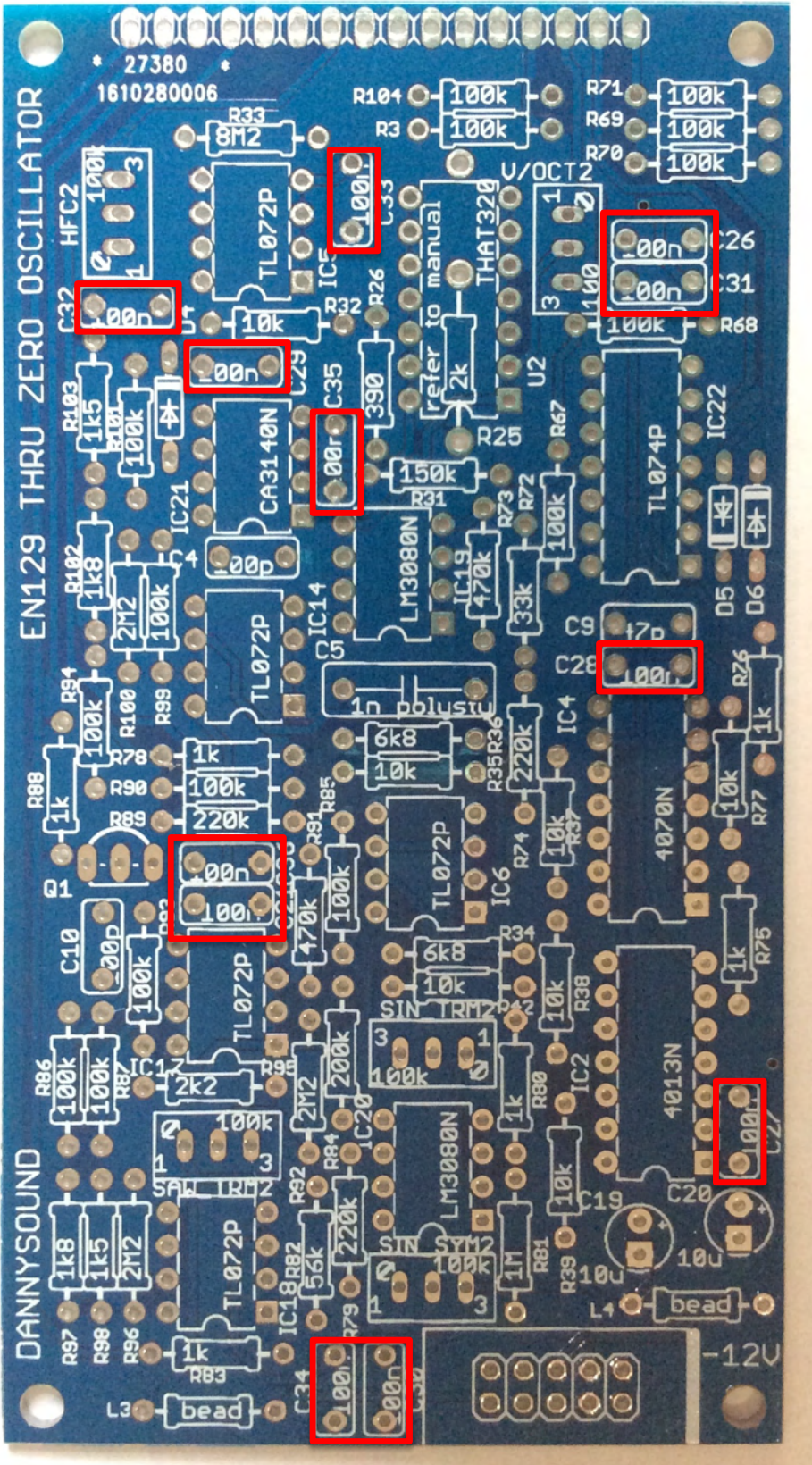

22 – 12 x 100nF capacitors

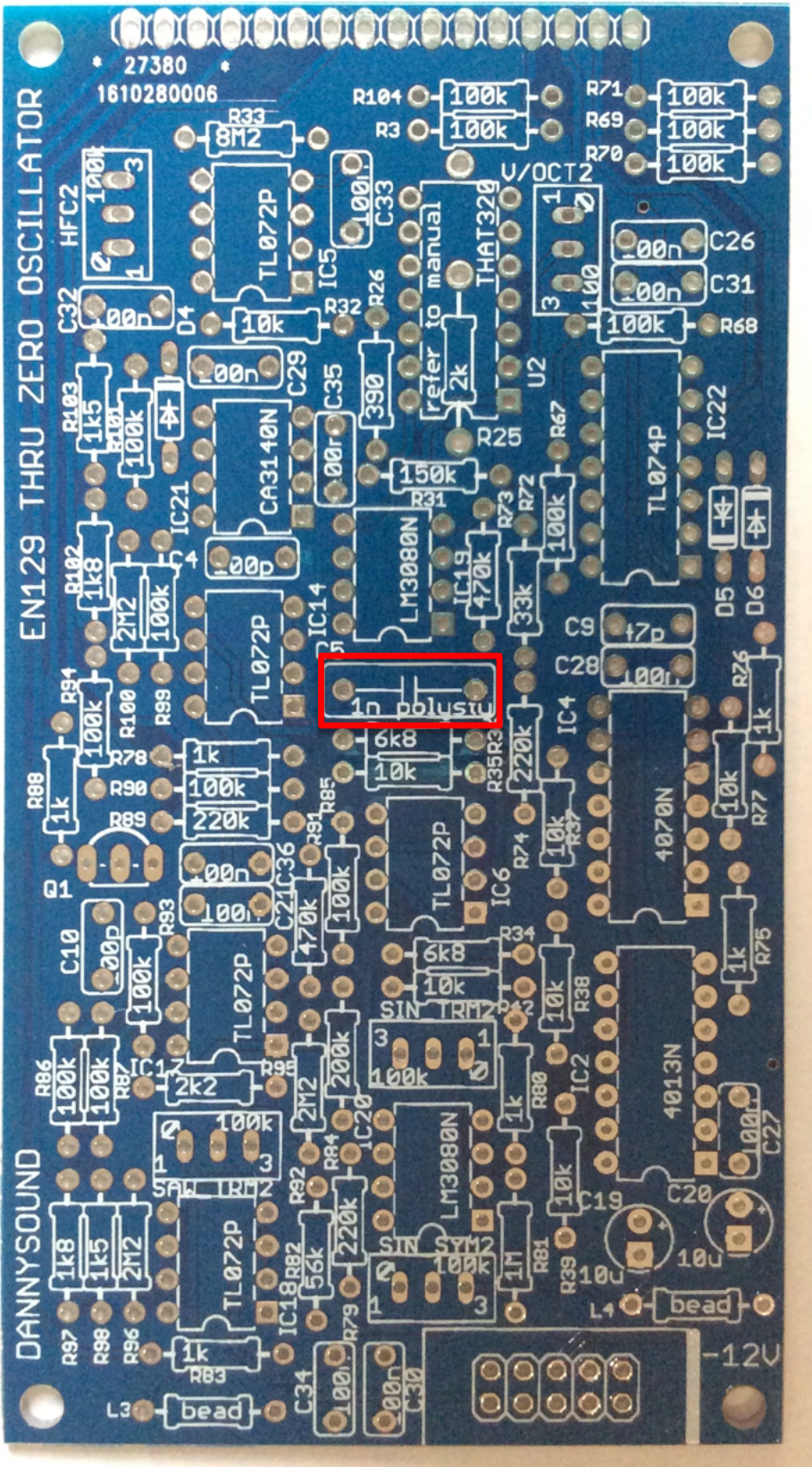

23 – 1 x 1nF silver polystyrene capacitor



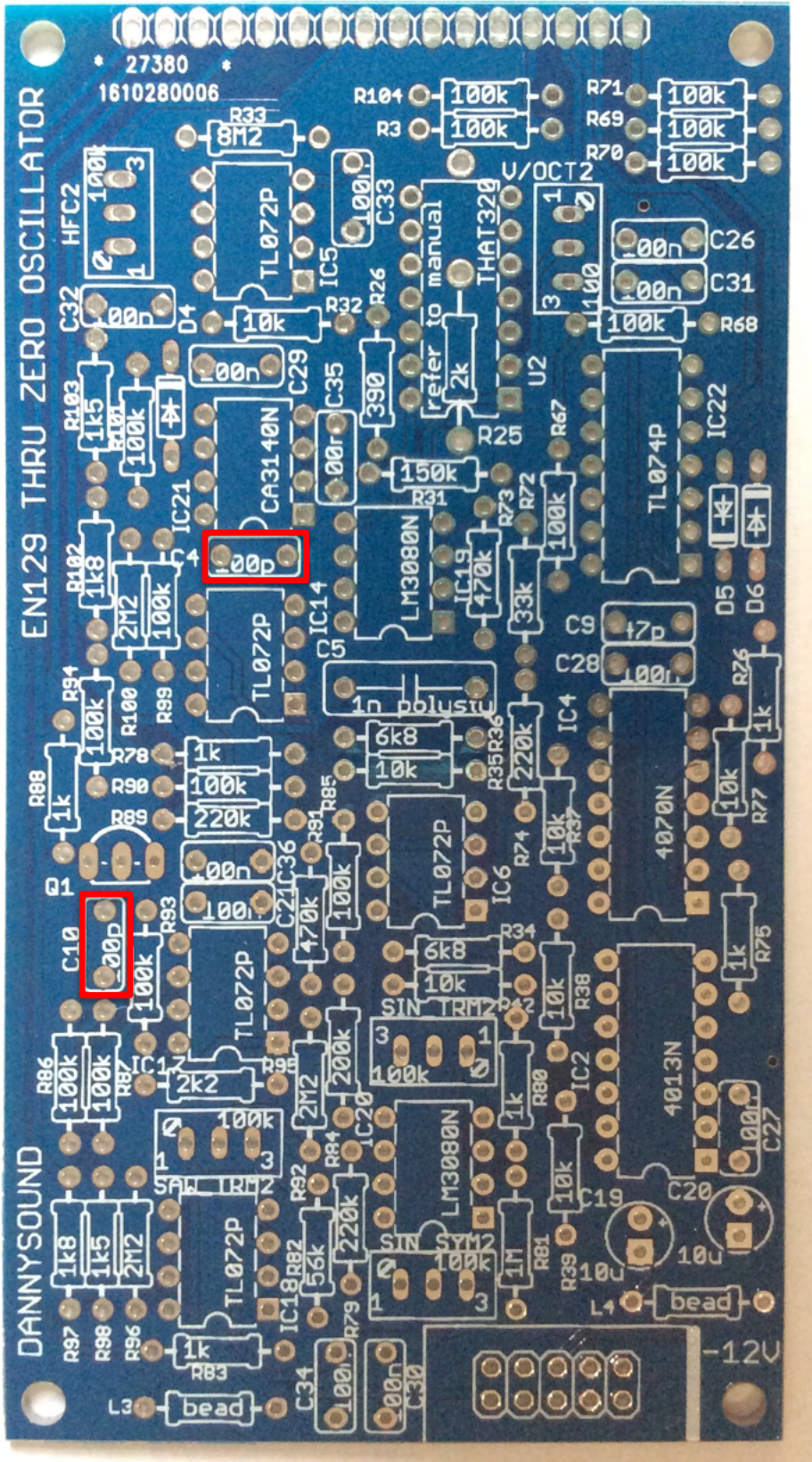

24 – 2 x 100pF capacitors

Transistors

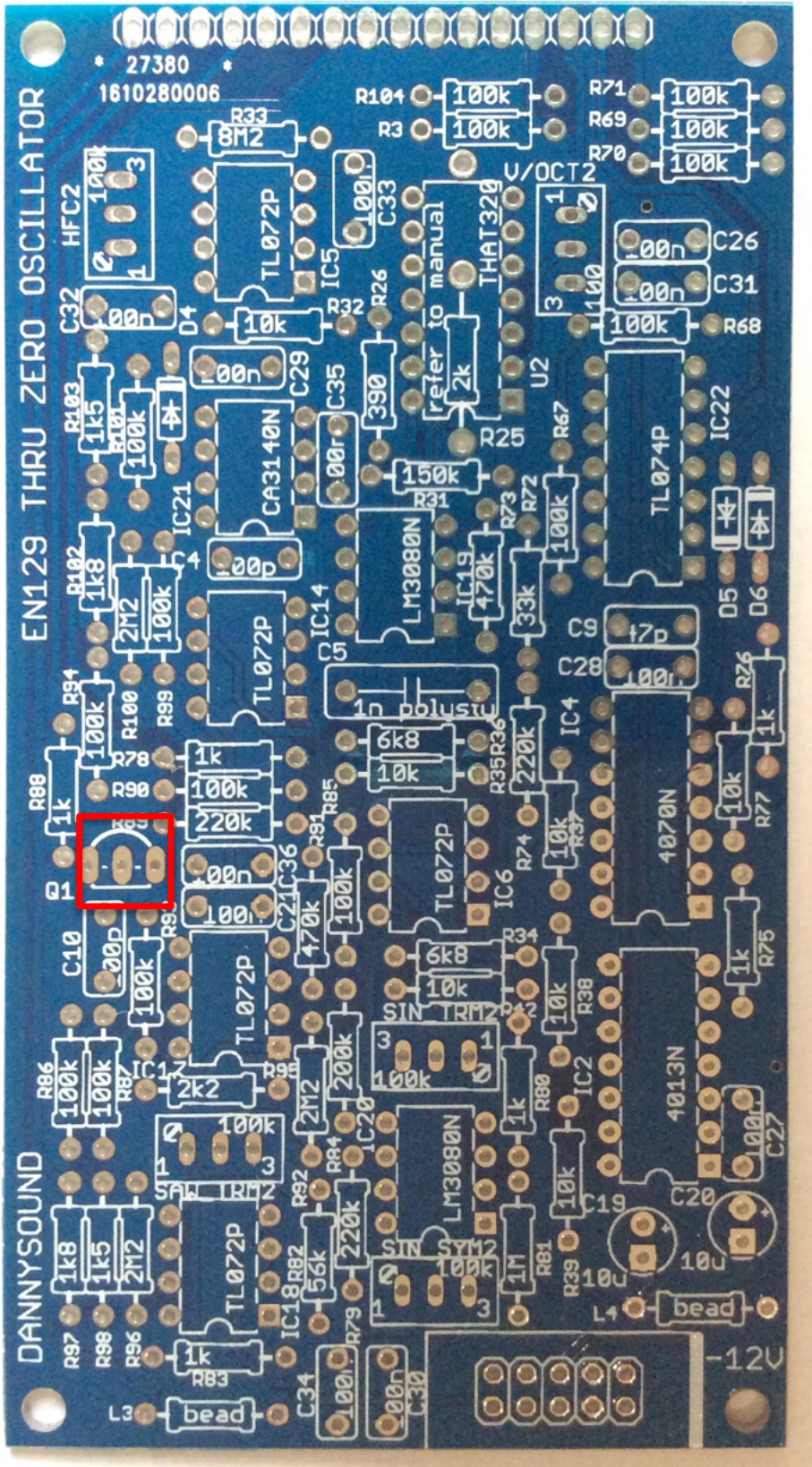

25 – 1 x MPF102 transistor – Orientation is vital - Ensure the flat face on the component matches the flat face on the PCB silkscreen.

Be careful to individually identify all the transistors, there are many different types to separate, make sure what you have matches the label on the transistor bag.

Power Socket

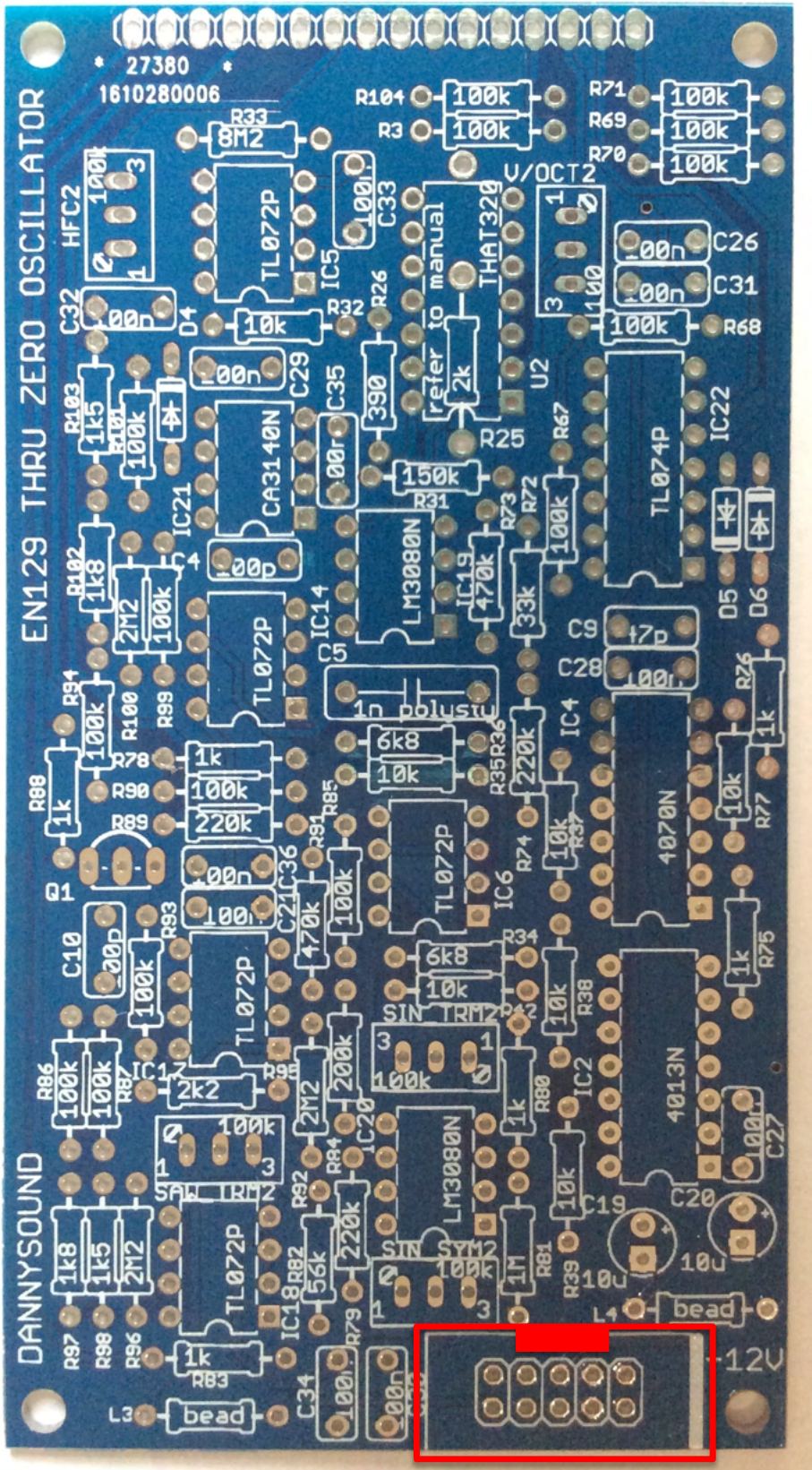

26 – 1 x power socket – **make sure the slot is facing away** from the edge of the PCB as indicated above. Orientation is vital!

Trim Pots

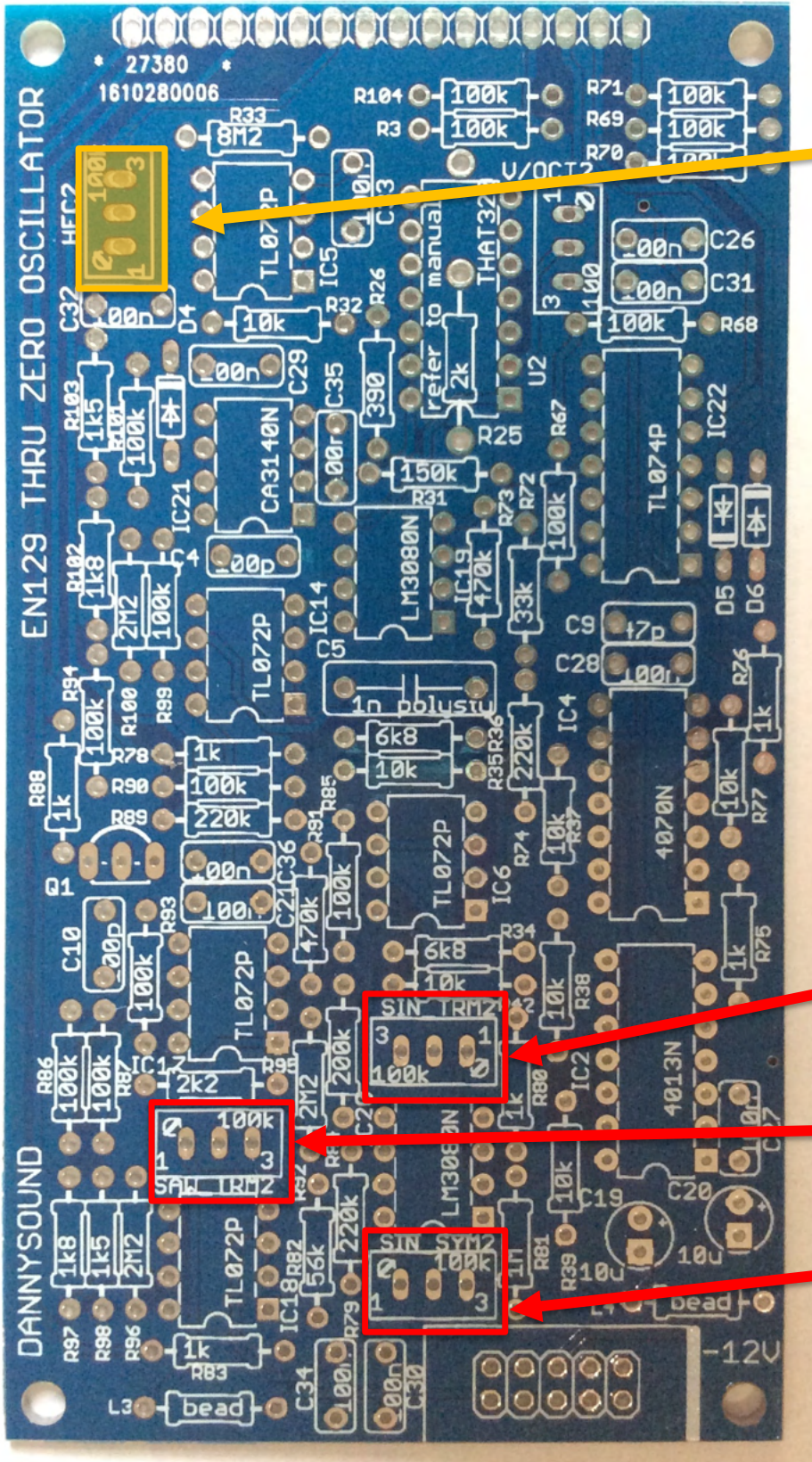

DO NOT PLACE HERE
NOT REQUIRED FOR
STANDARD THINK
BUILD

SINE TRIM

SAW TRIM

SINE SYM

27 – 3 x 100k blue trimpots

(The 'HFC' trimpot is there as a precaution for high frequency correction, where the oscillator pitch tracks fine up to a certain point then starts to get flatter in the higher frequencies. This has not been required in any of the modules tested so far and is not included in the Think kit.)

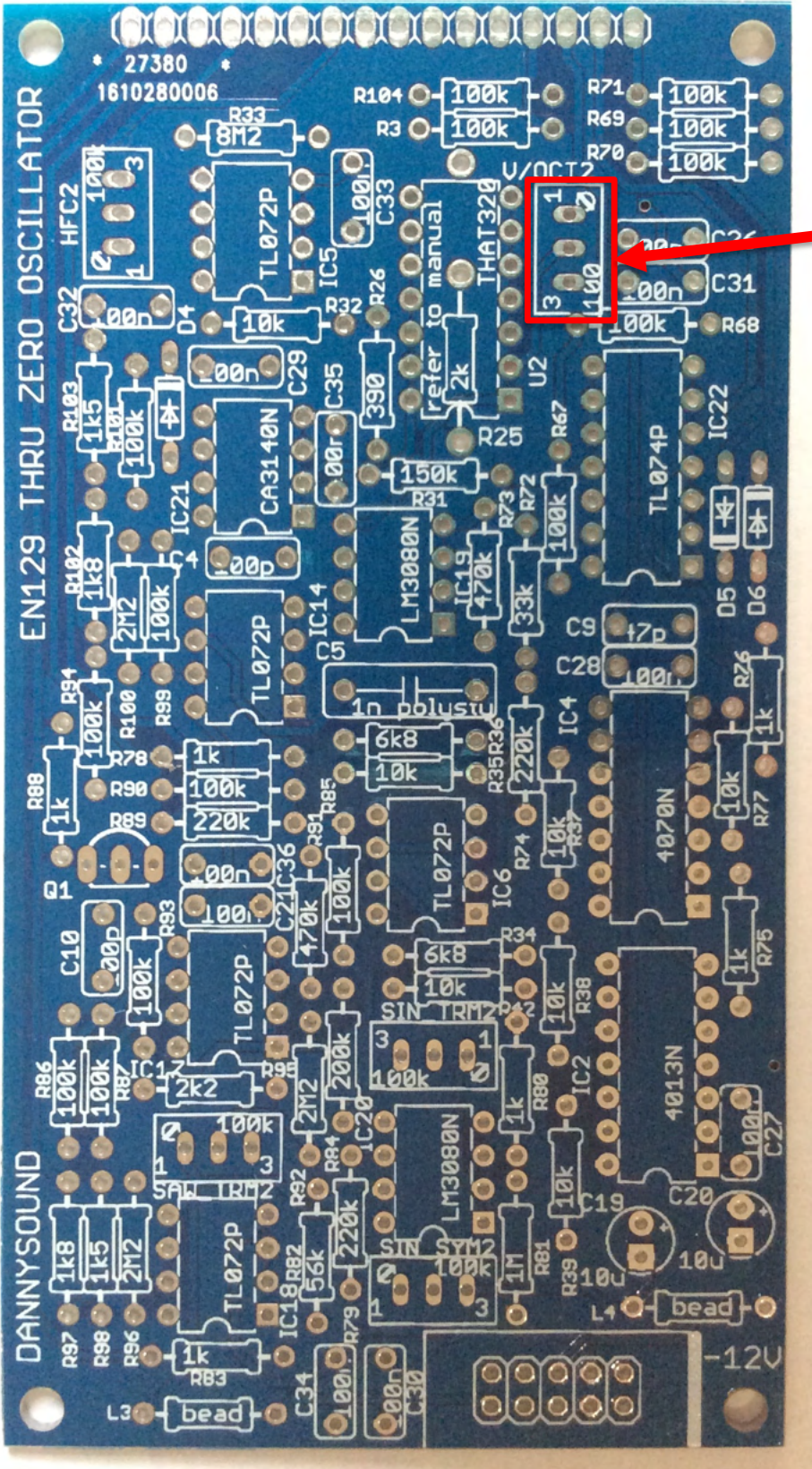

V/OCT

28 – 1 x 100r blue trimpot

Electrolytic Capacitors

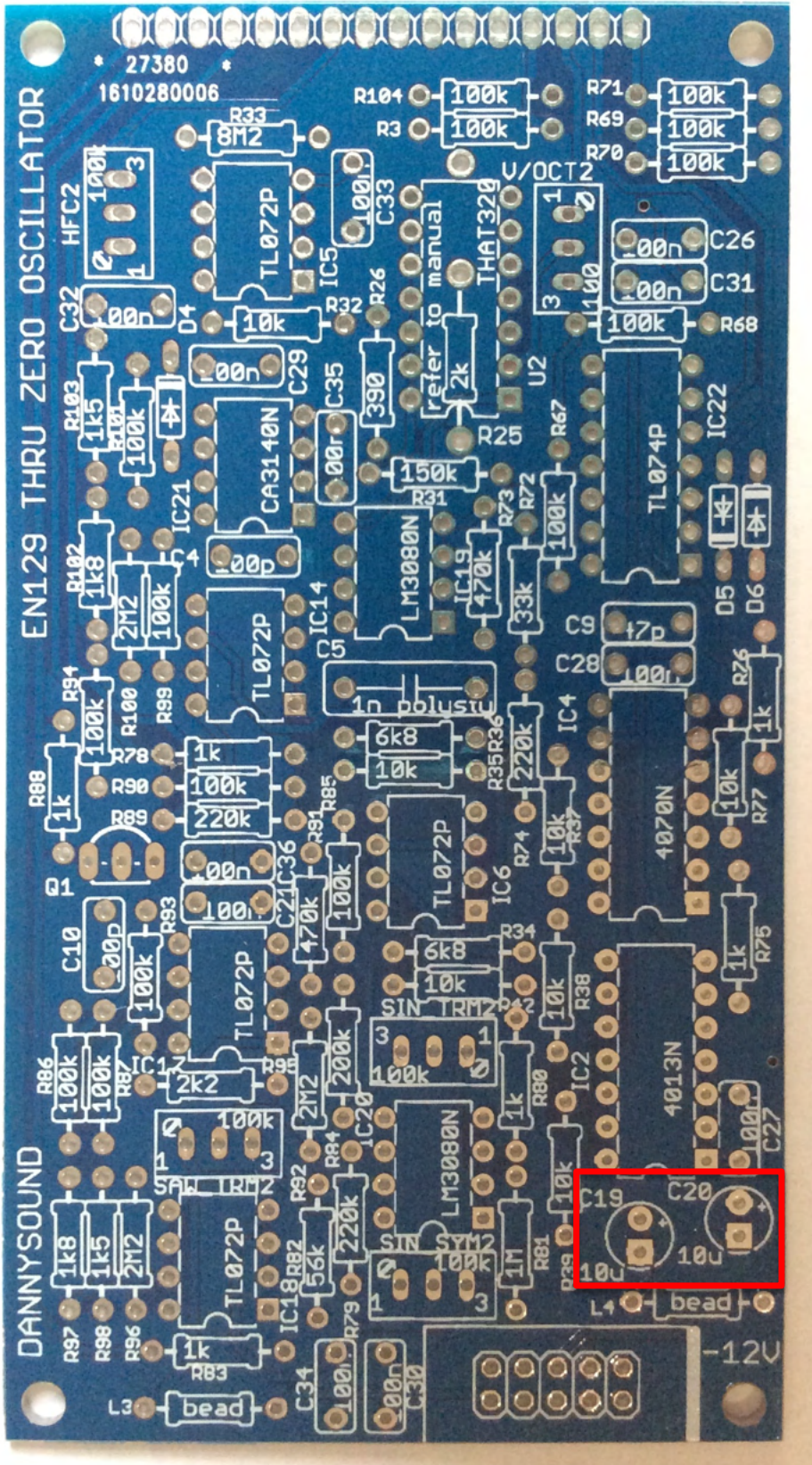

29 – 2 x 10uF capacitor - orientation is vital, the longer lead on the component should go to the circular pad marked with a plus '+' on the PCB. Note the component has a grey stripe on the cylindrical body on the minus side.

Board Connector

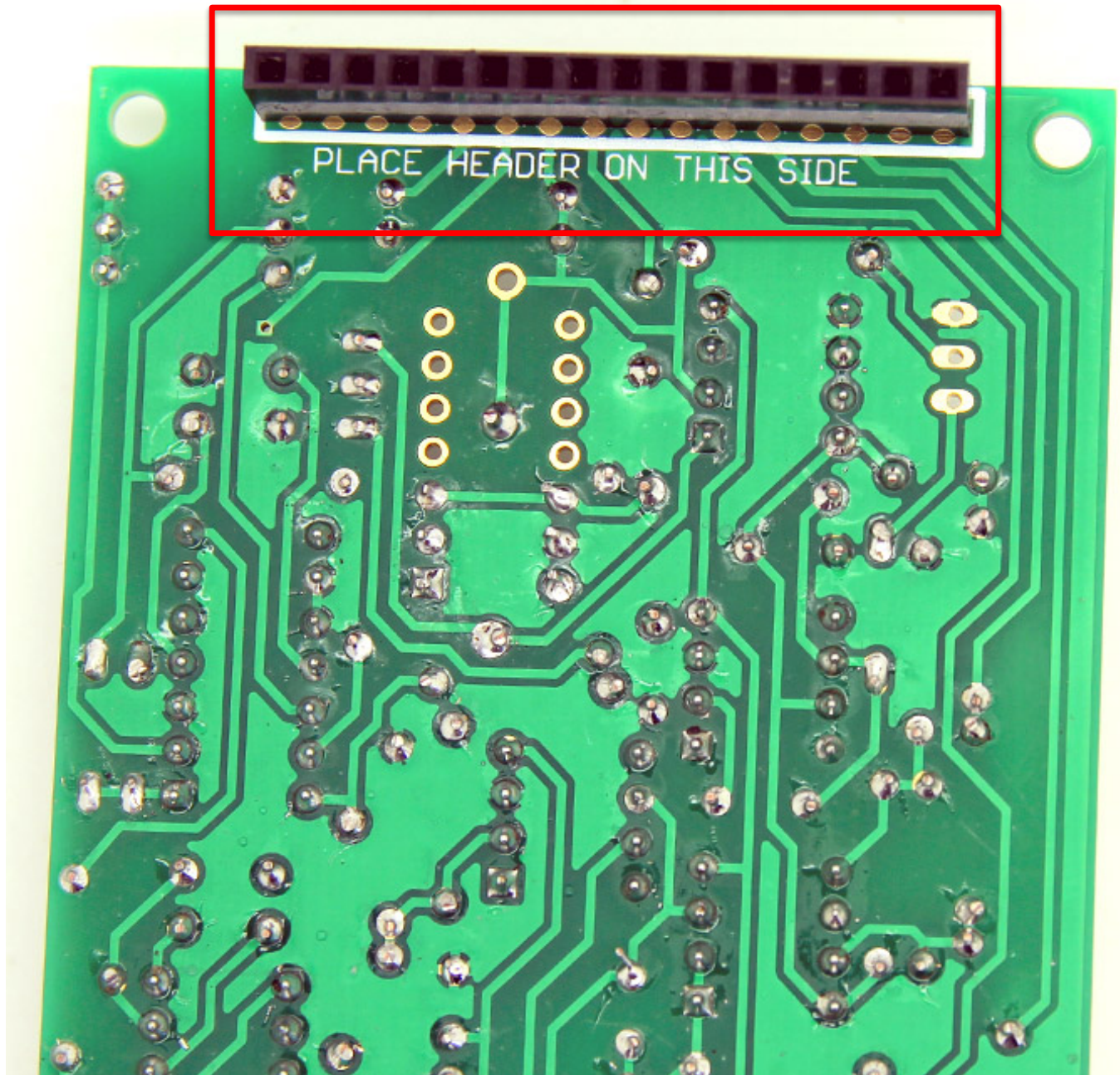

30 – Female connector

Section 2 – Power Test, Matched Transistors and IC placement

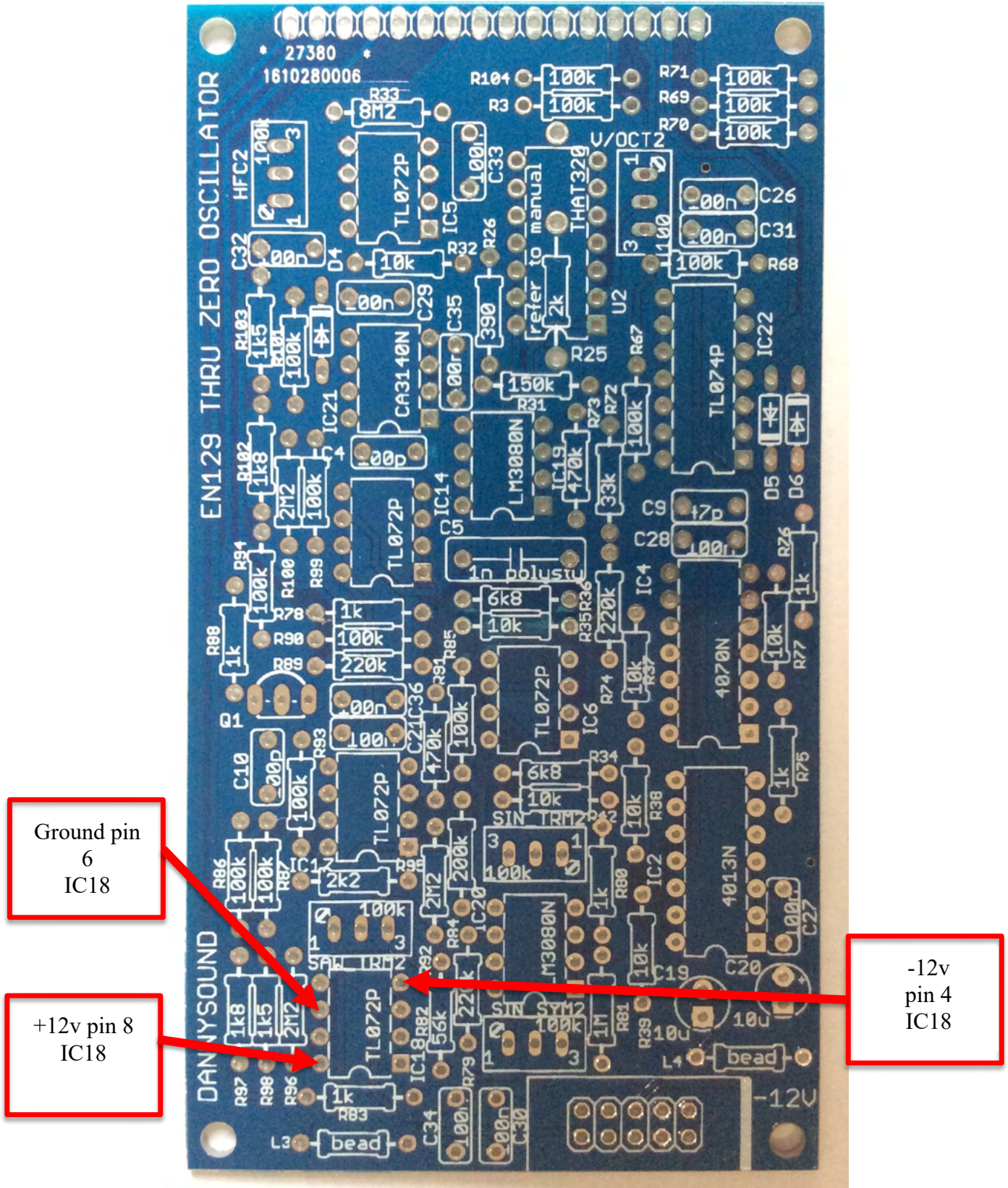

1 – test power

Take note of transistor orientation.
Place transistors as close together as possible.

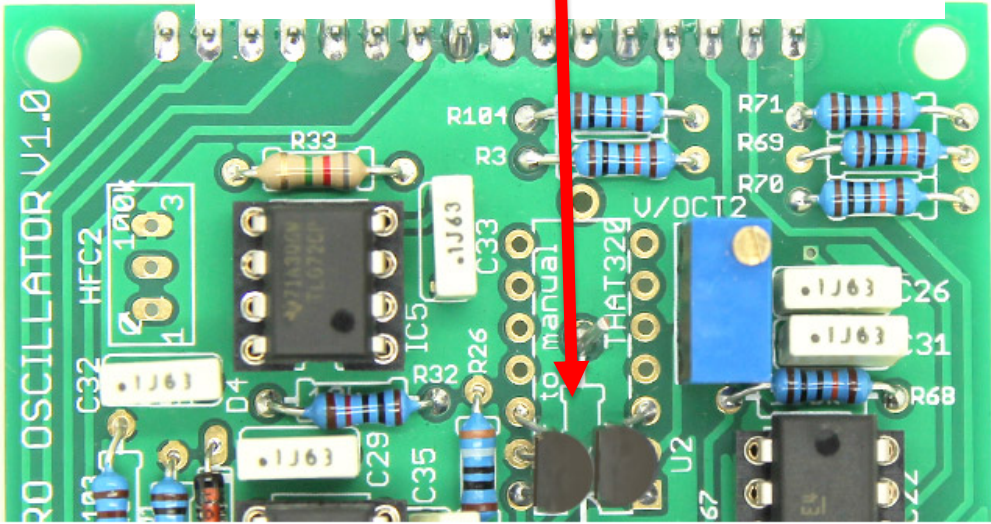

2 – 1 x matched pair of 2N3906s, both transistors have their flat edge facing towards C29. Orientation is vital. (The matched pair is located in the Panel/PCB bag)

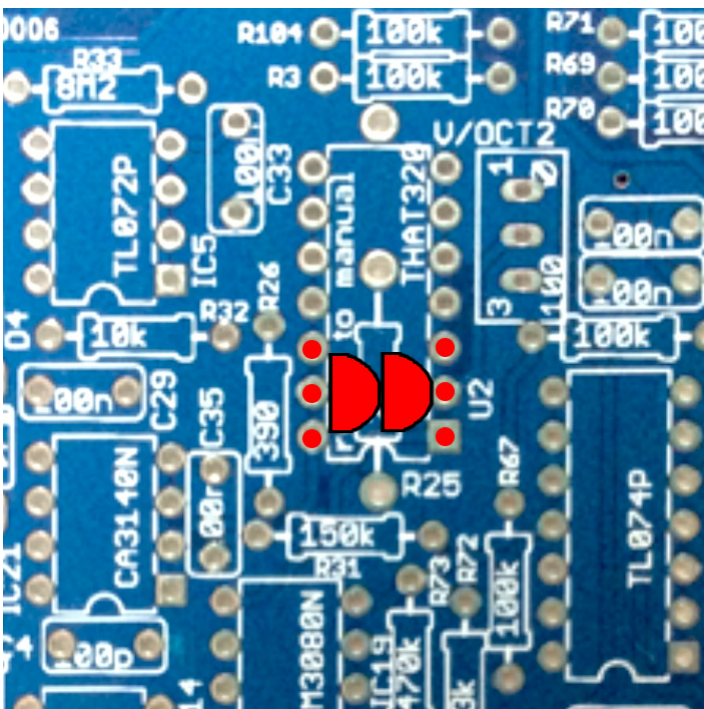

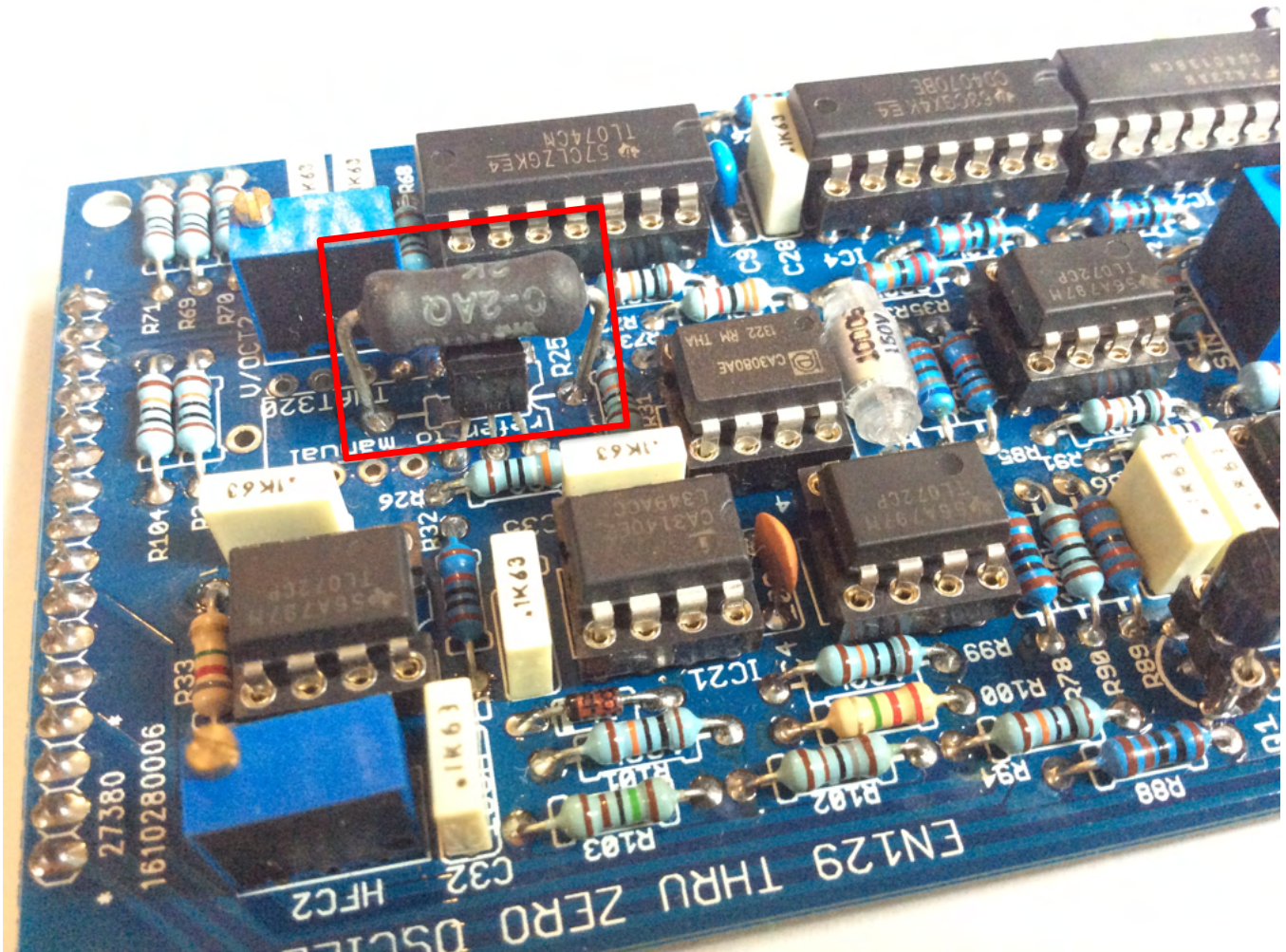

3 – 1 x 2k TEMPCO resistor – solder the tempco so that it's touching the matched pair below it

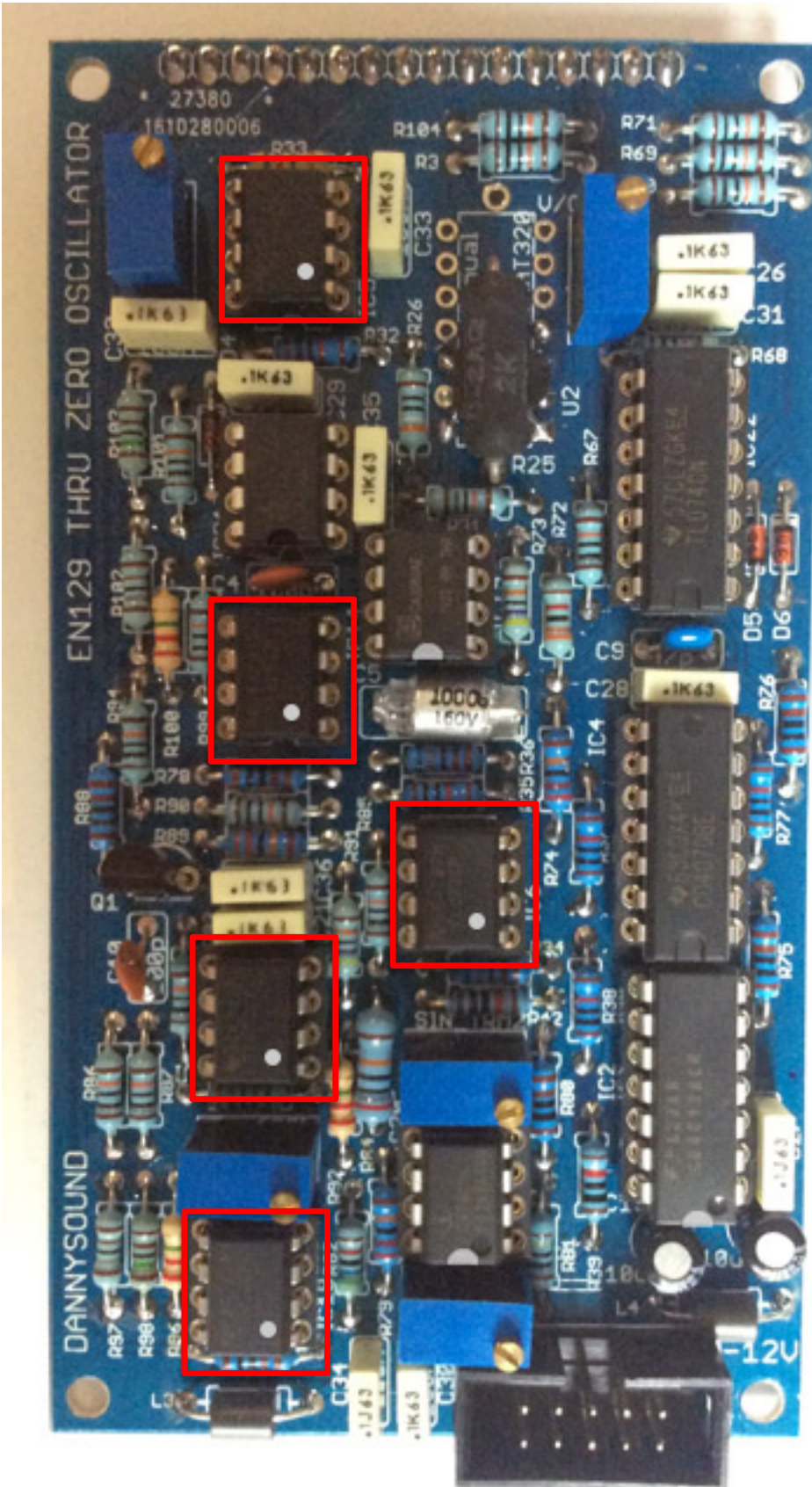

4 – 5 x TL072 opamps – orientation is vital, for these opamps match the dot with the notch on the PCB silkscreen and IC Socket

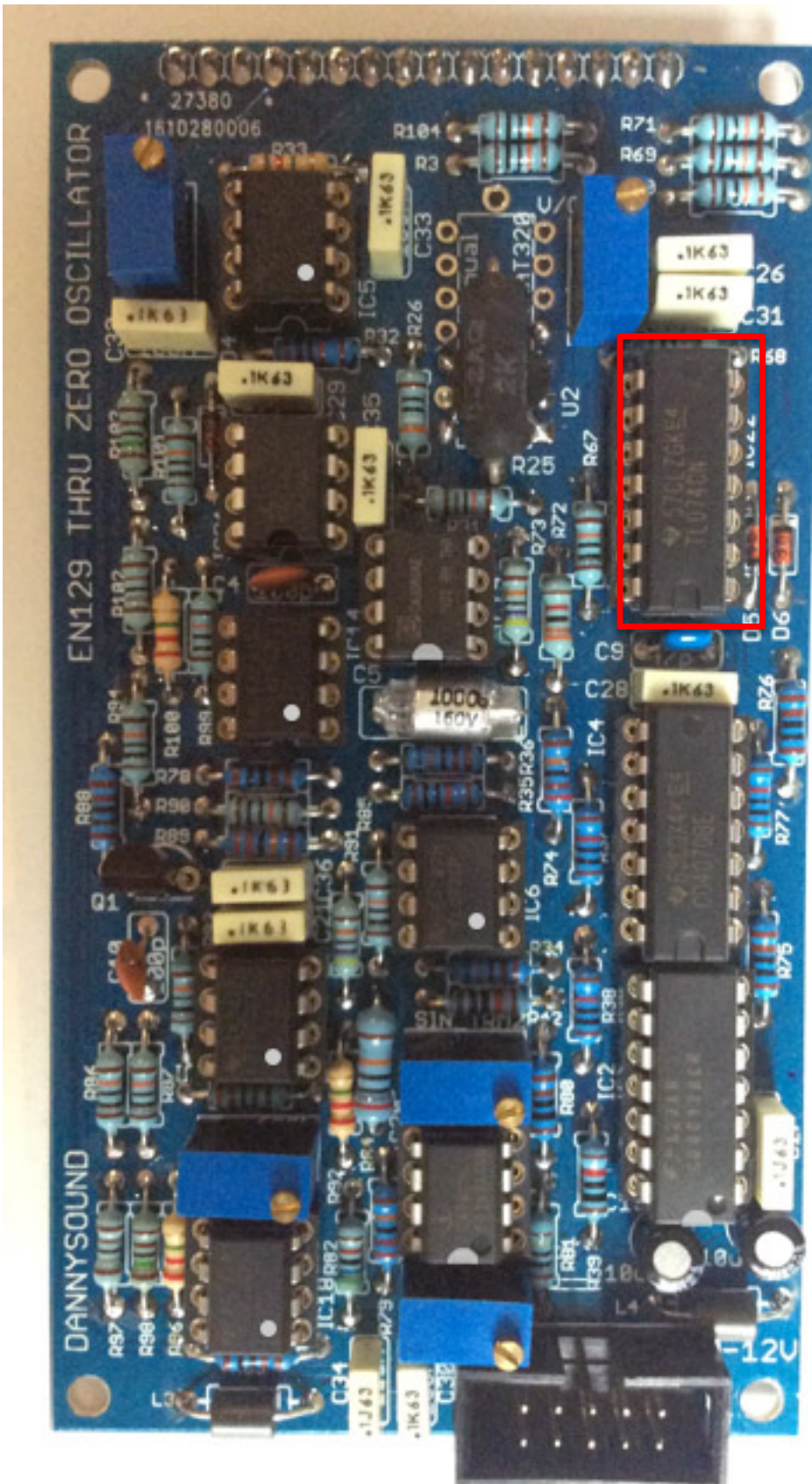

5 – 1 x TL074 opamp - match the notch on the chip with the notch on the PCB silkscreen and IC Socket - orientation is vital.

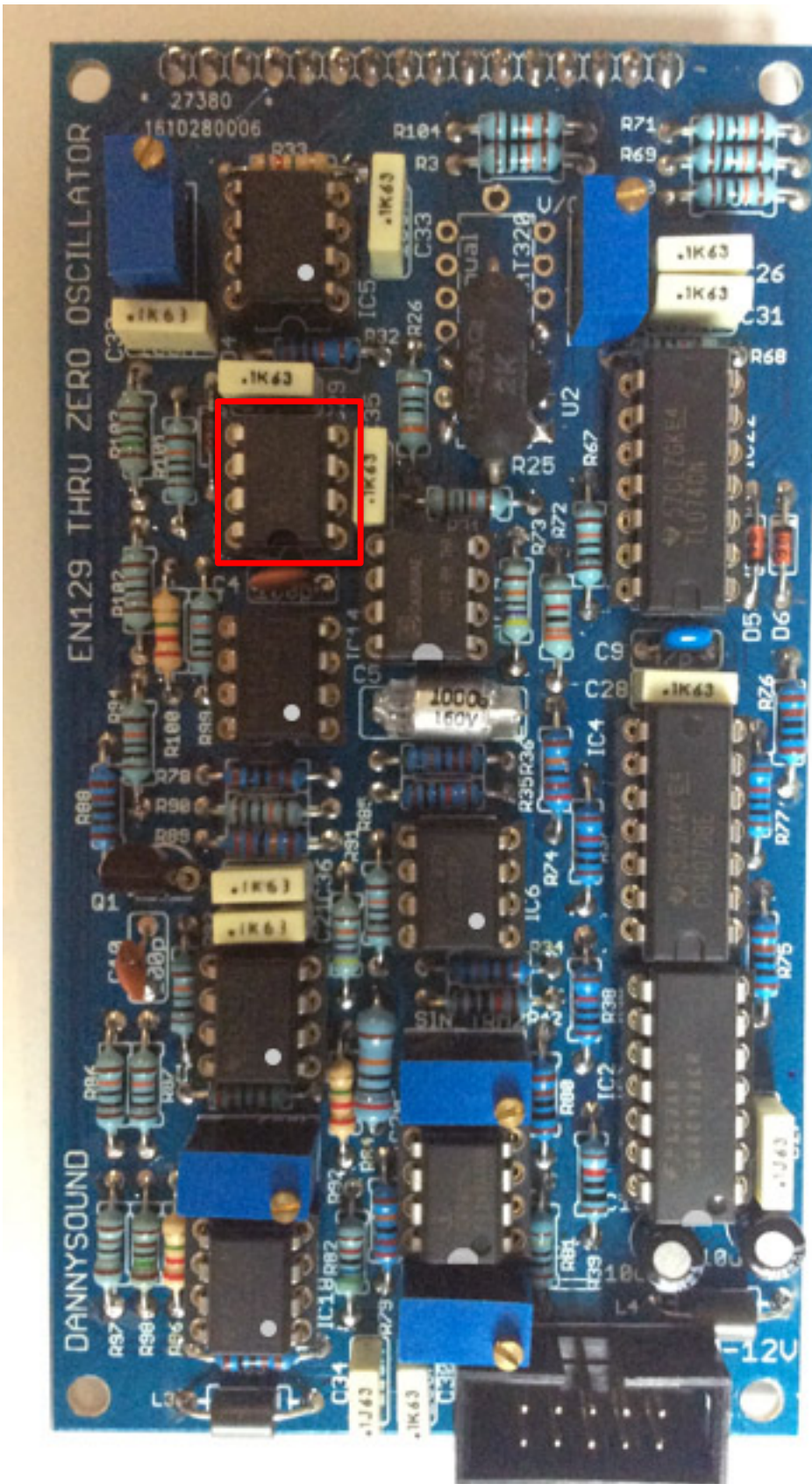

6 – 1 x CA3140 opamp - match the notch on the chip with the notch on the PCB silkscreen and IC Socket - orientation is vital

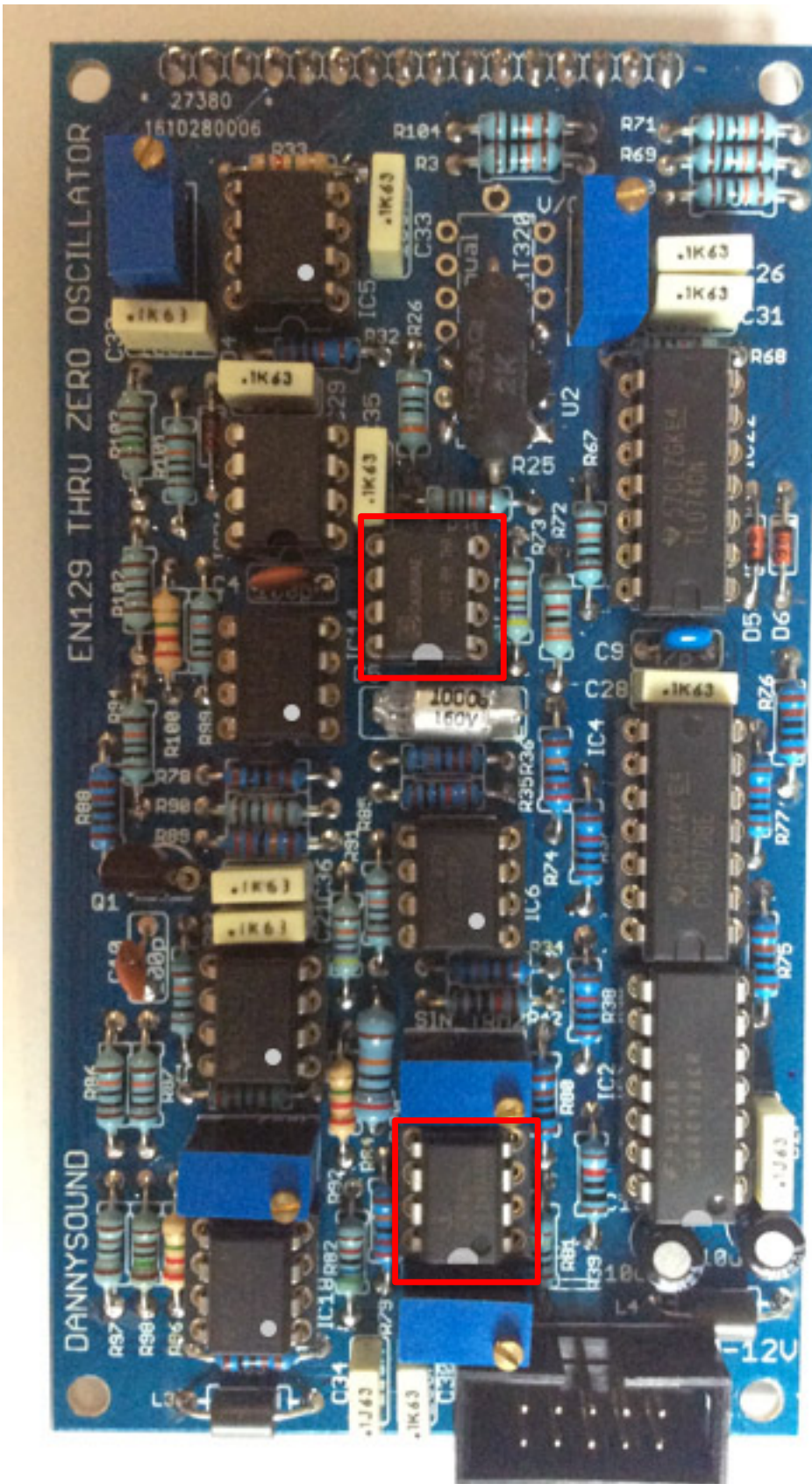

7 – 2 x CA3080 opamps - match the notch on the chip with the notch on the PCB silkscreen and IC Socket - orientation is vital

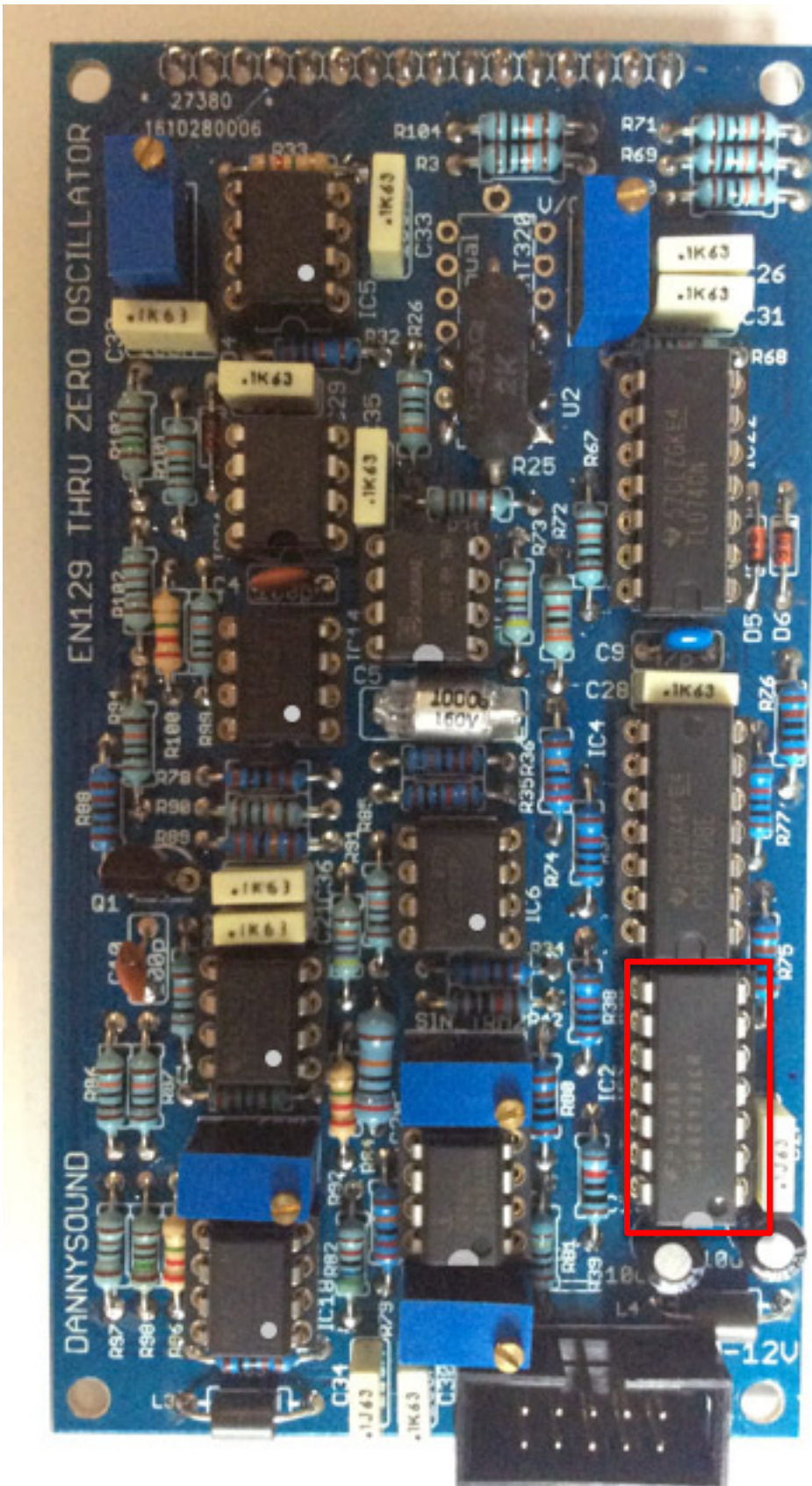

8 – 1 x CD4013 - match the notch on the chip with the notch on the PCB silkscreen and IC Socket - orientation is vital

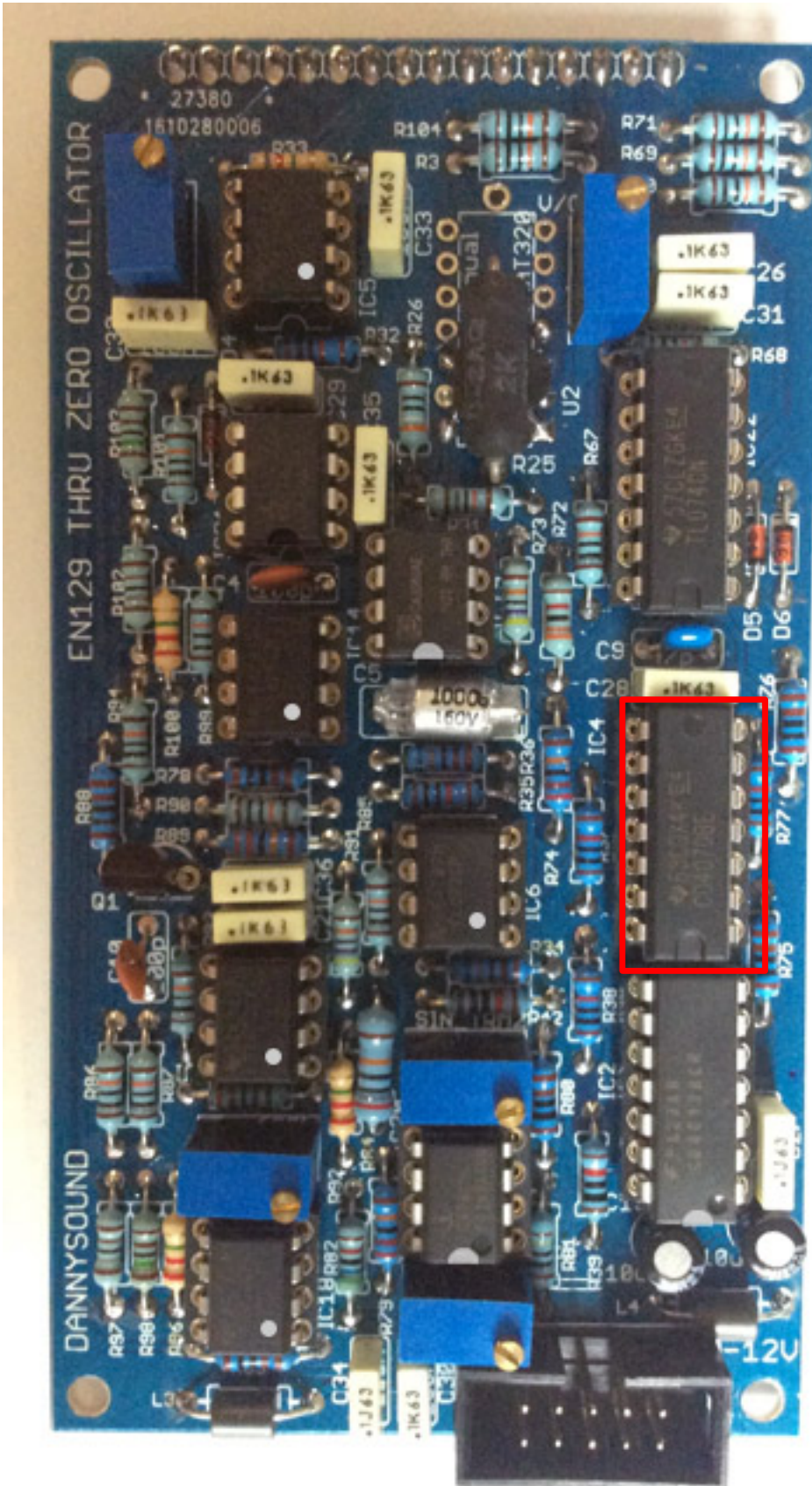

8 – 1 x CD4070 - match the notch on the chip with the notch on the PCB silkscreen and IC Socket - orientation is vital

Section 3 – Pots PCB

Resistors

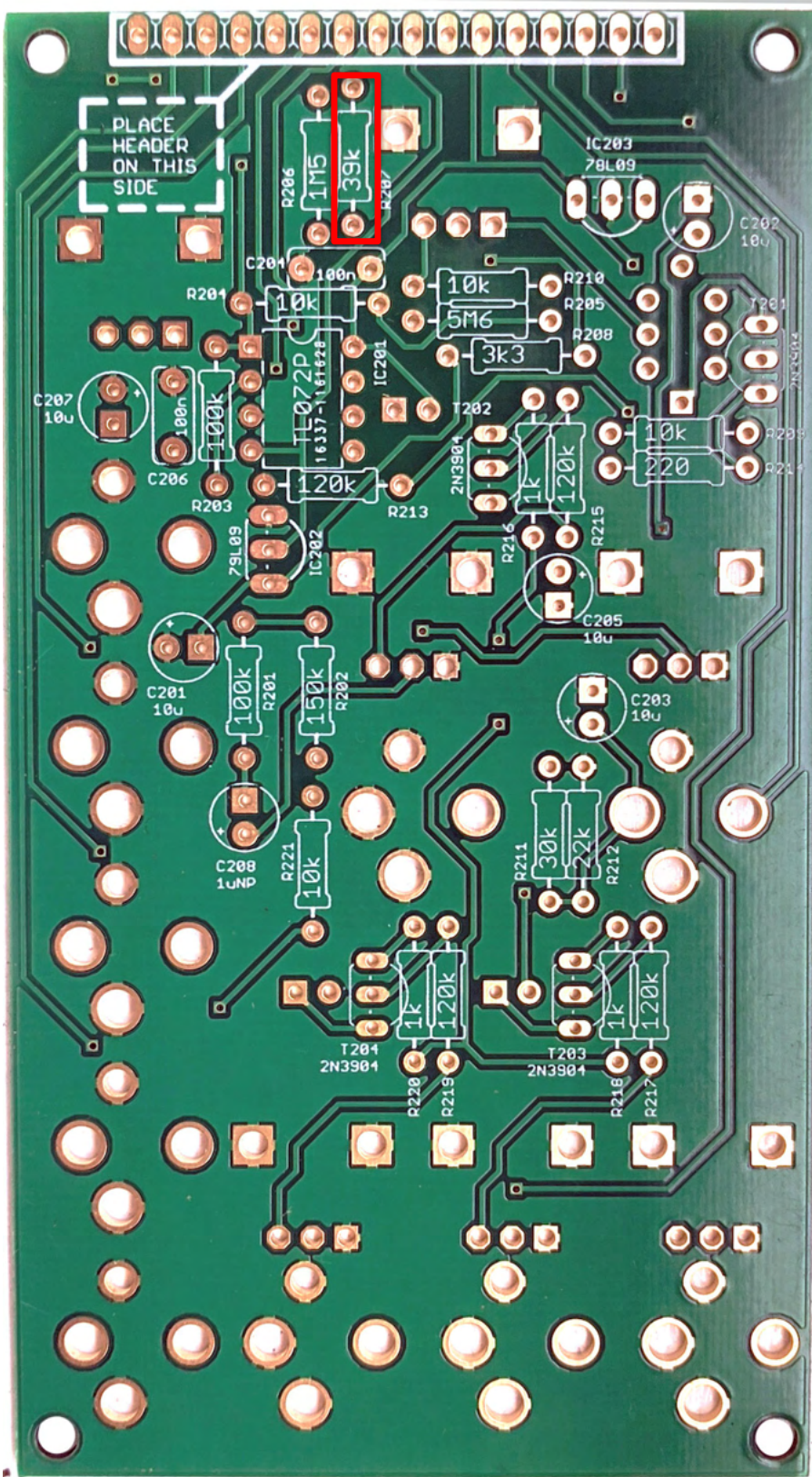

1 x 39K resistor

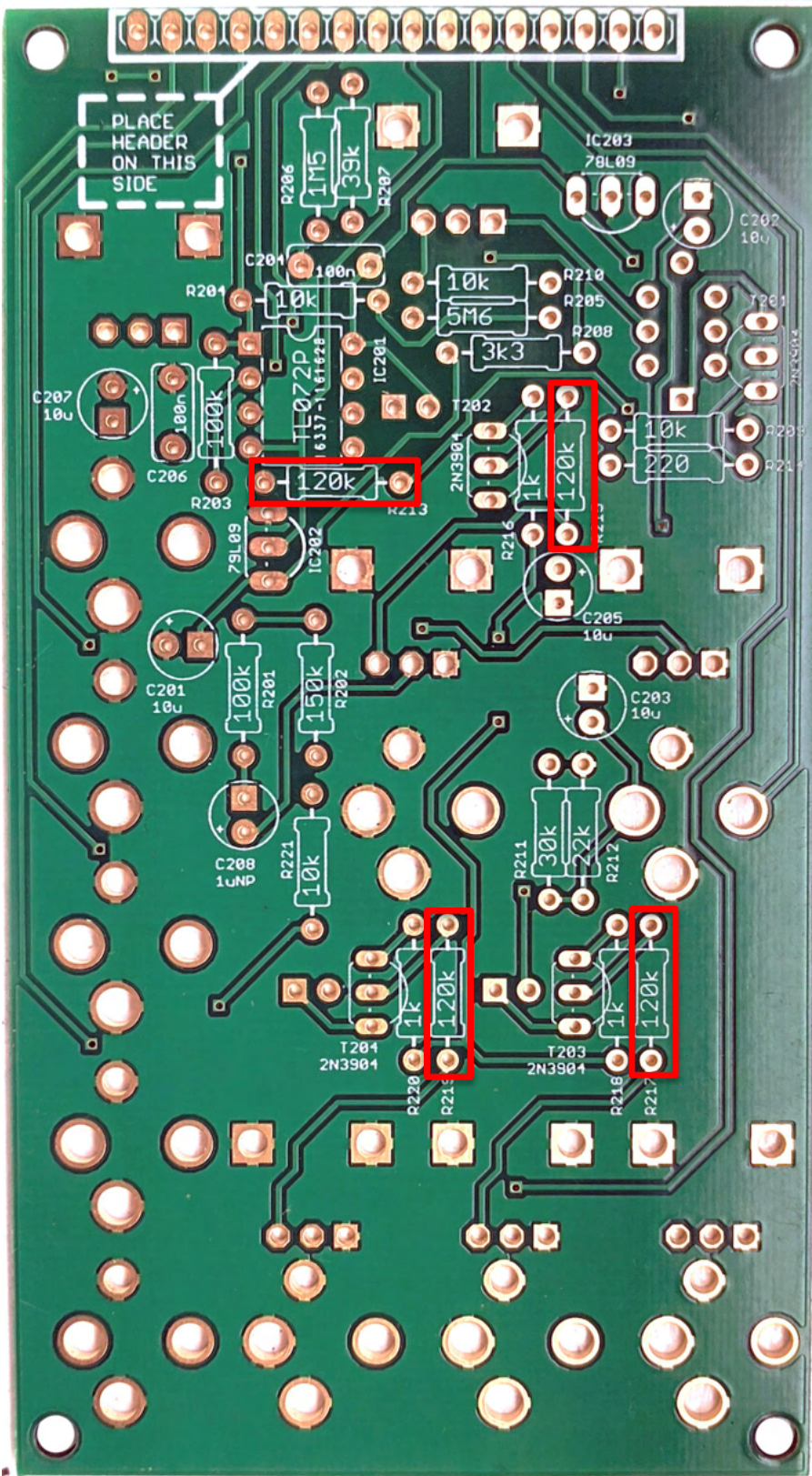

1 – 4 x 120k resistors

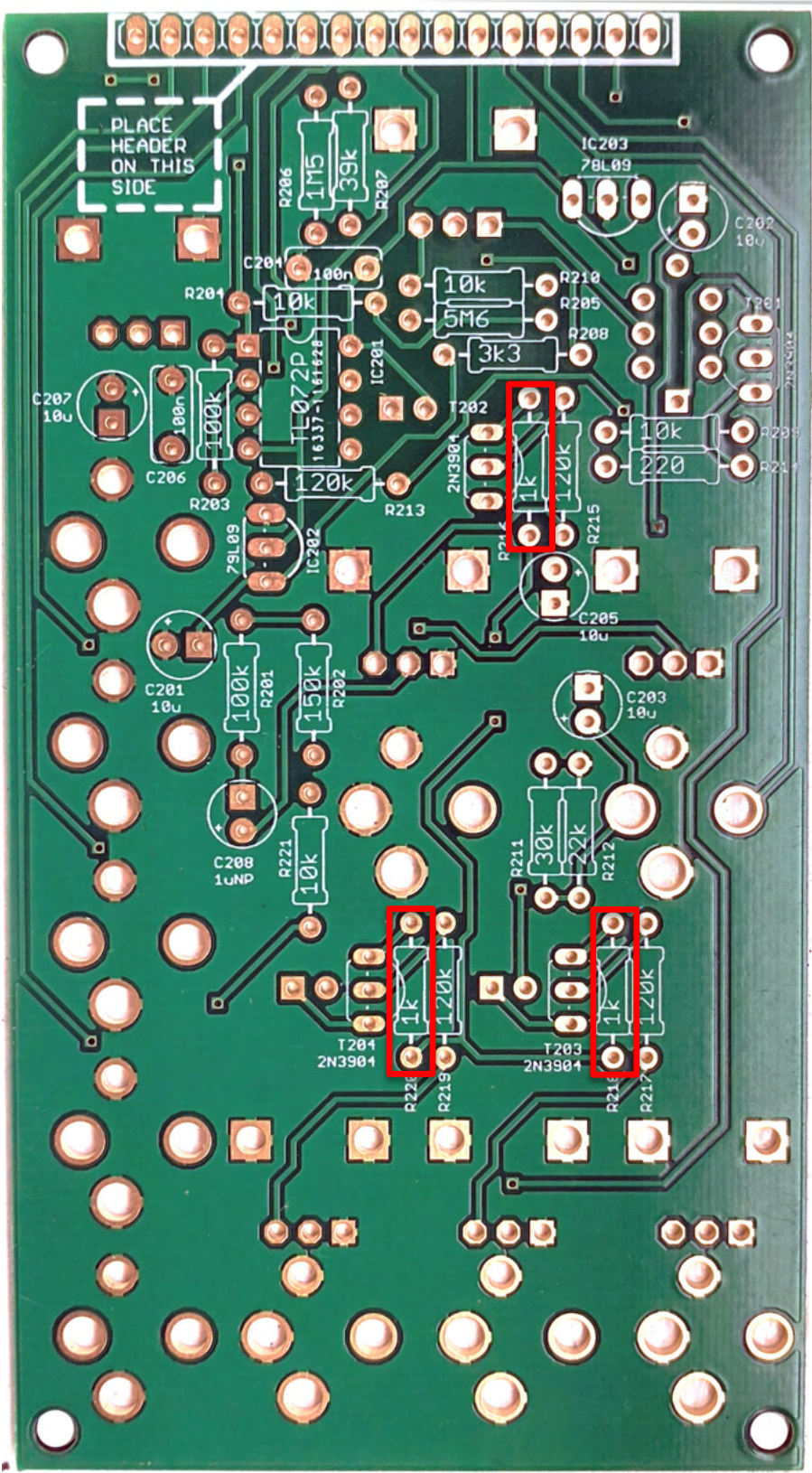

2 – 3 x 1k resistors

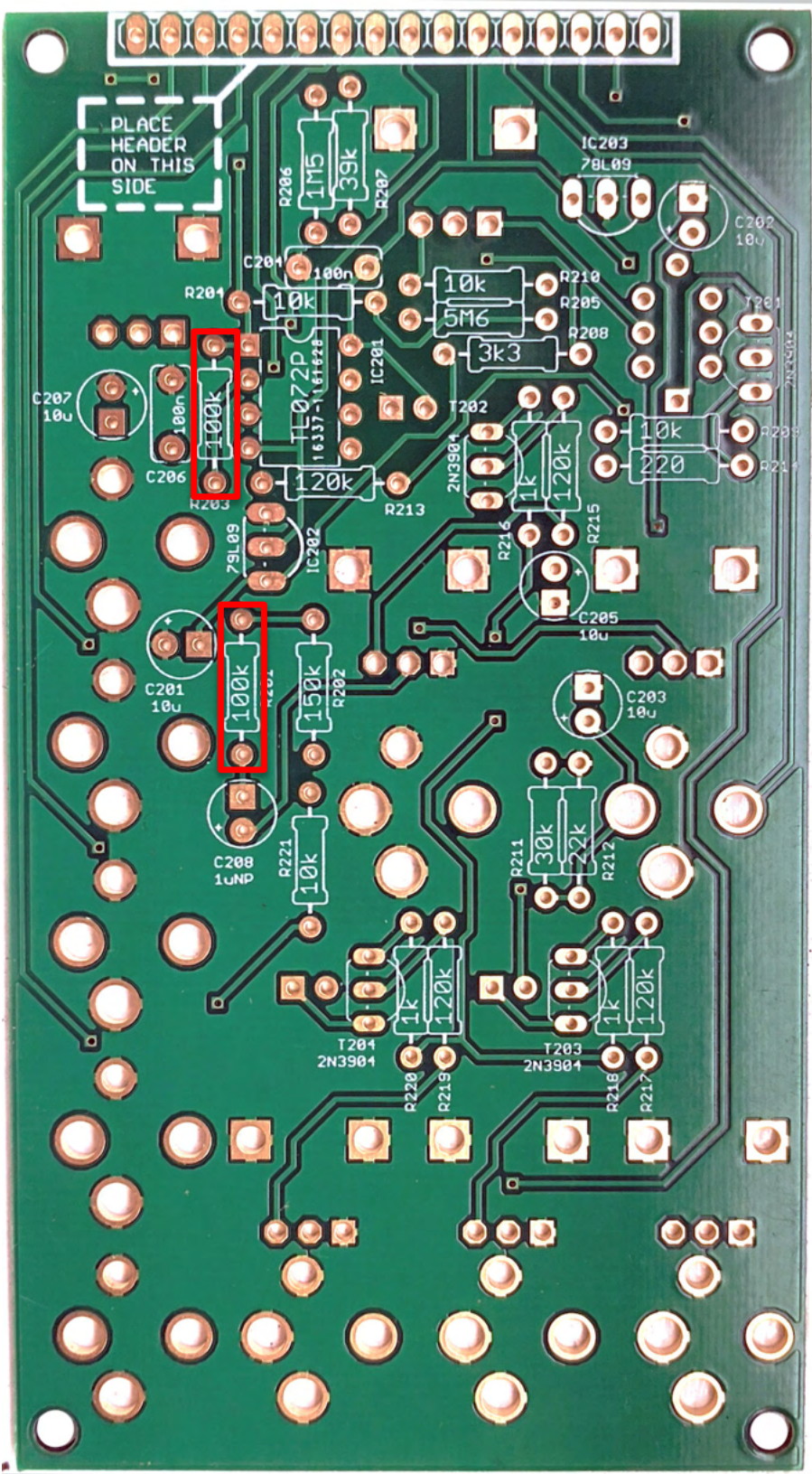

3 – 2 x 100k resistors

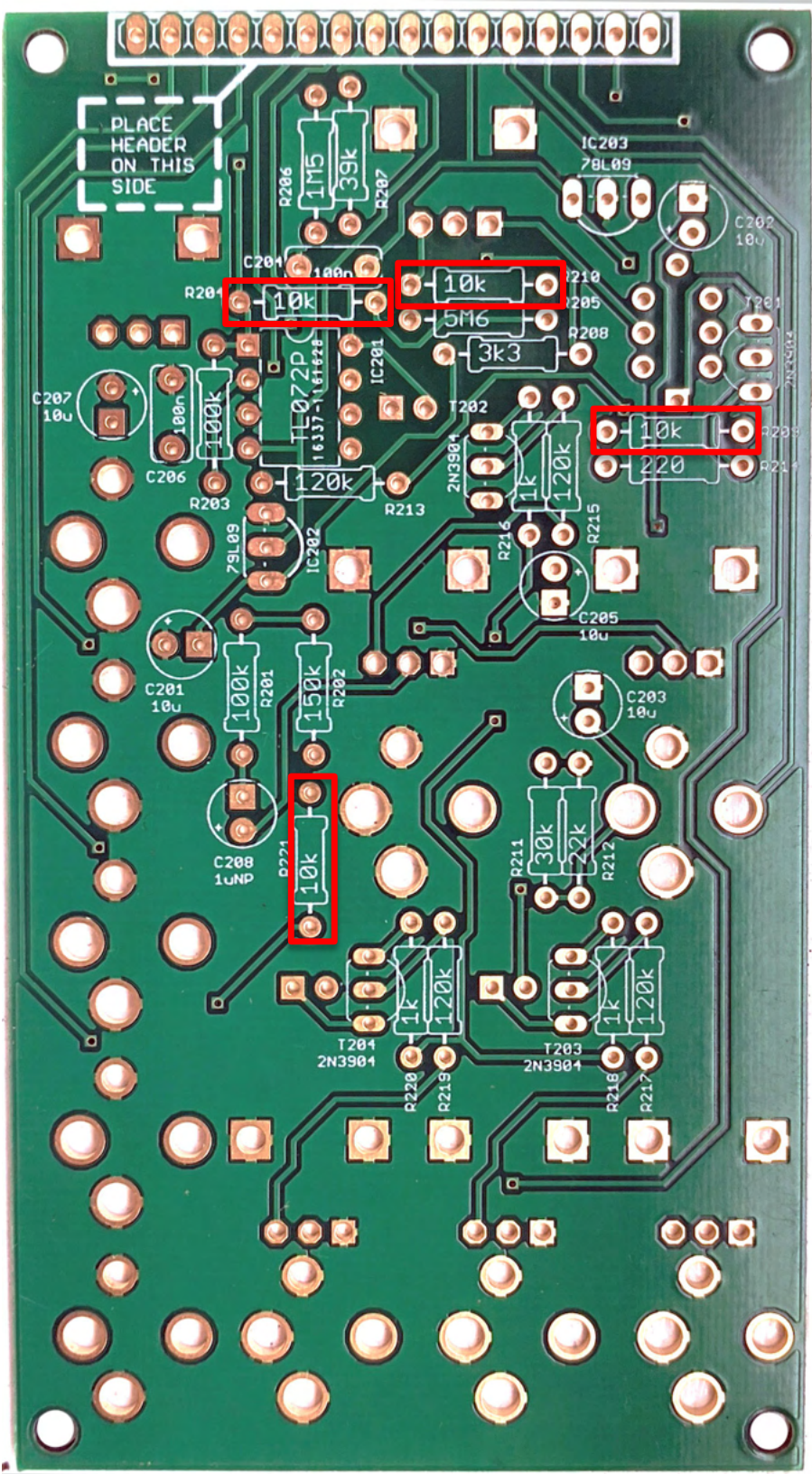

4 – 4 x 10k resistors

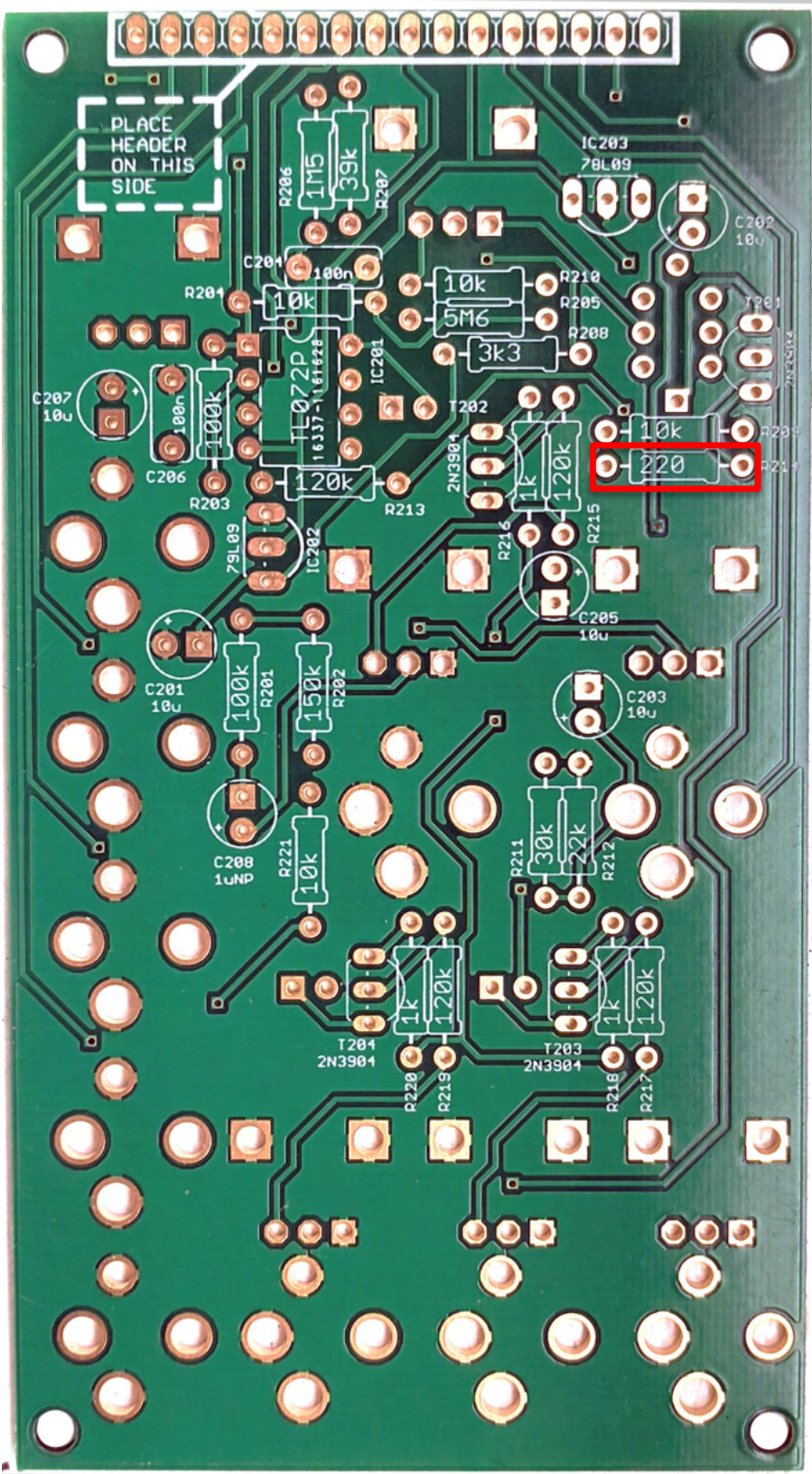

5 – 1 x 220R resistor

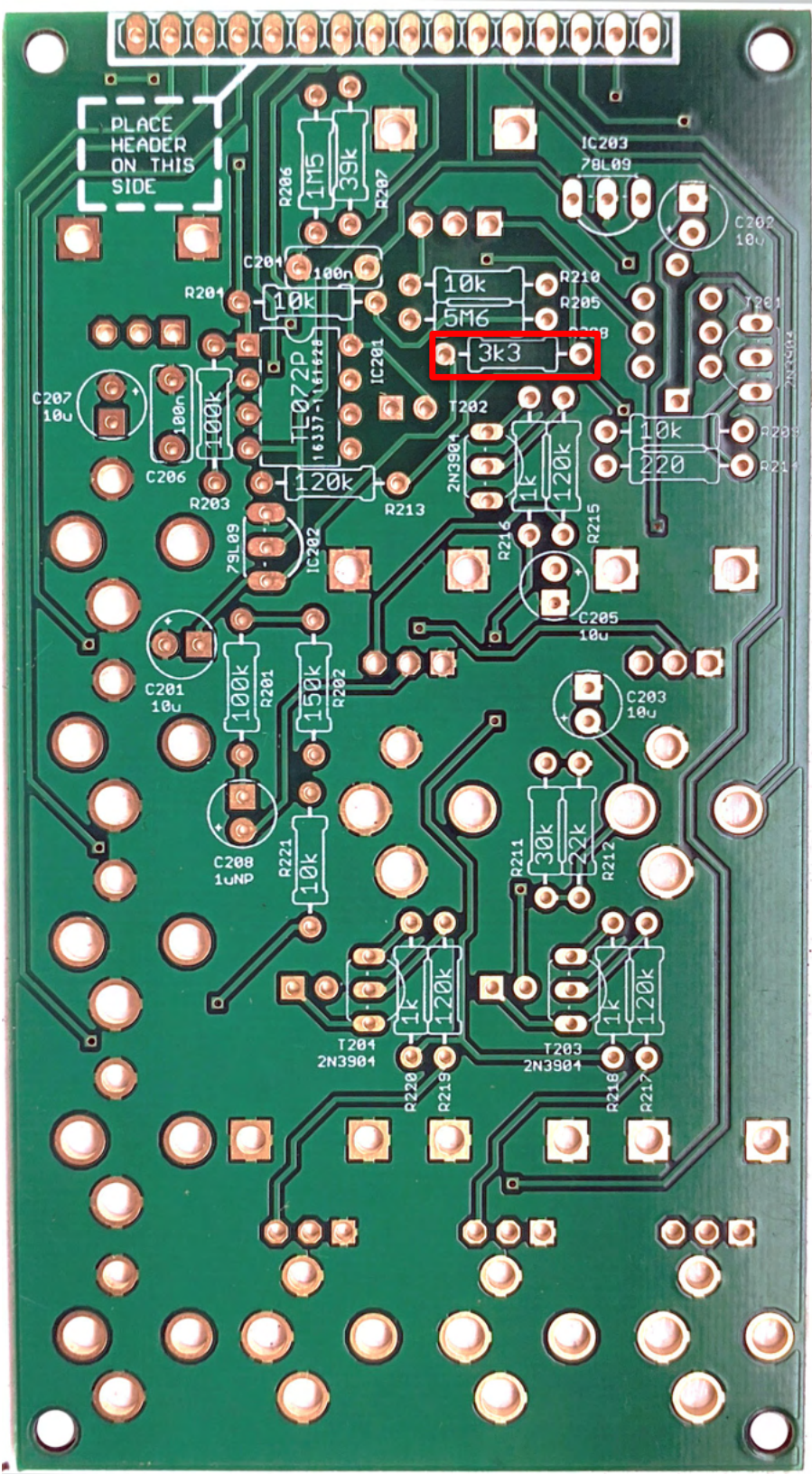

6 – 1 x 3k3 resistor

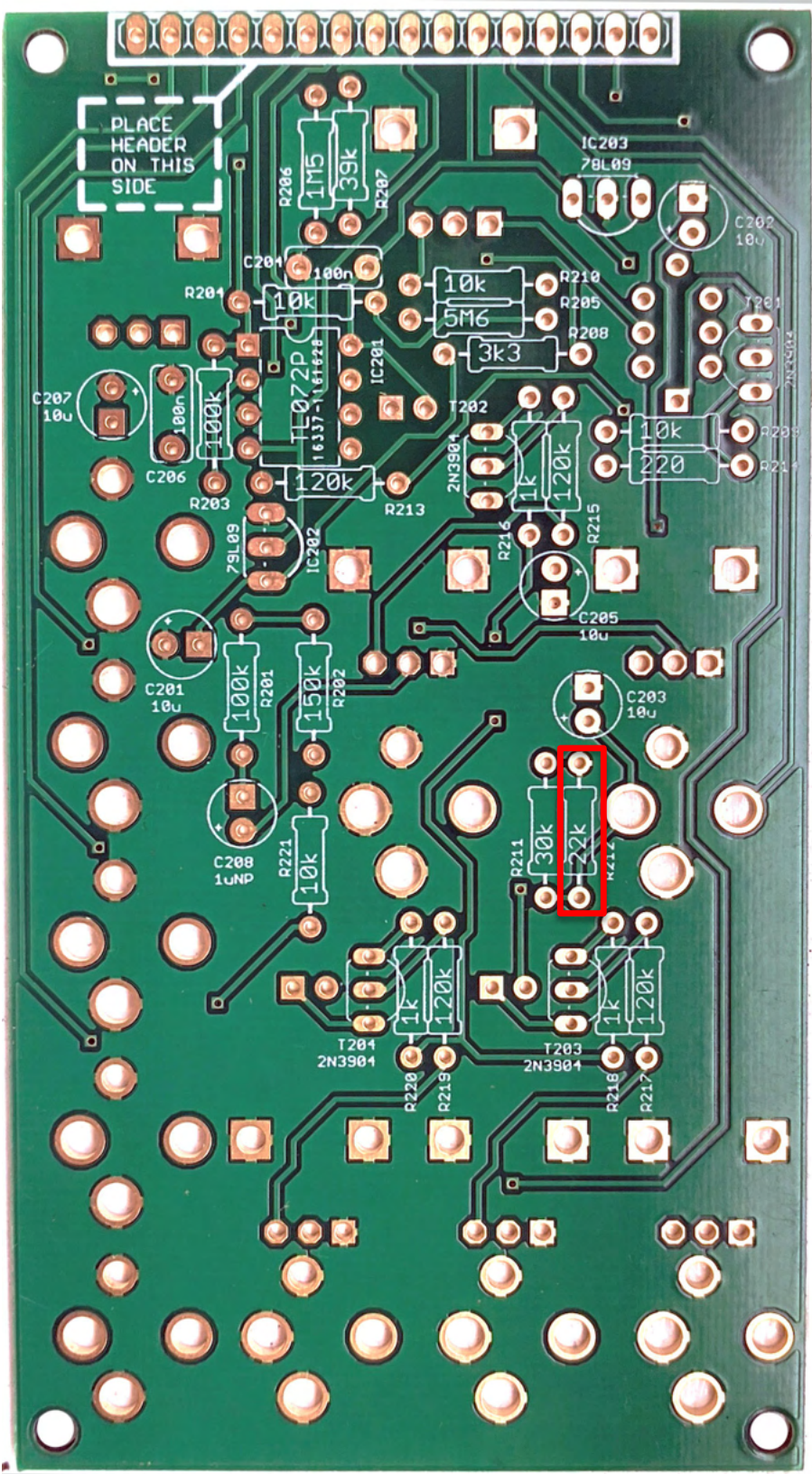

7 – 1 x 22k resistor

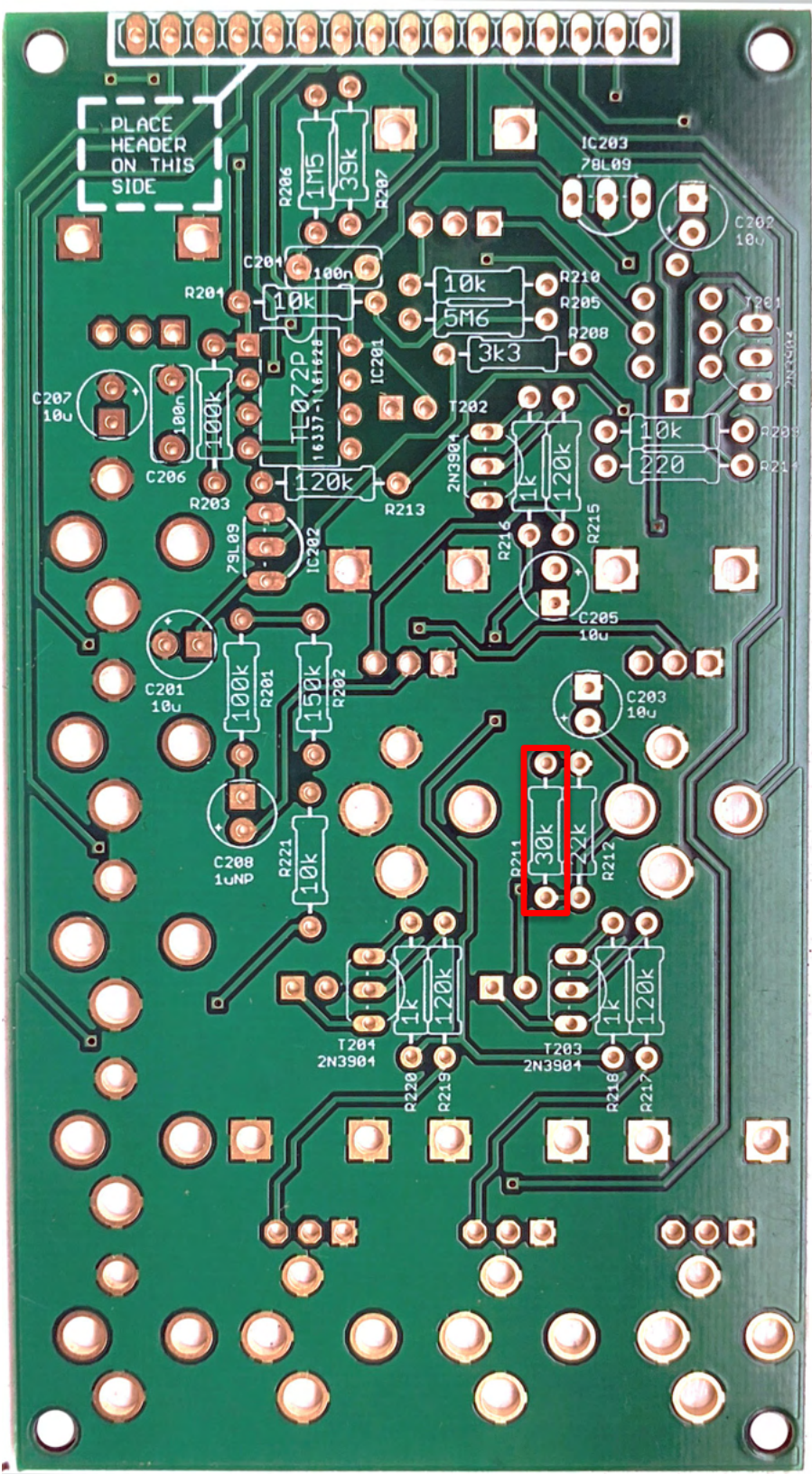

8 – 1 x 30k resistor

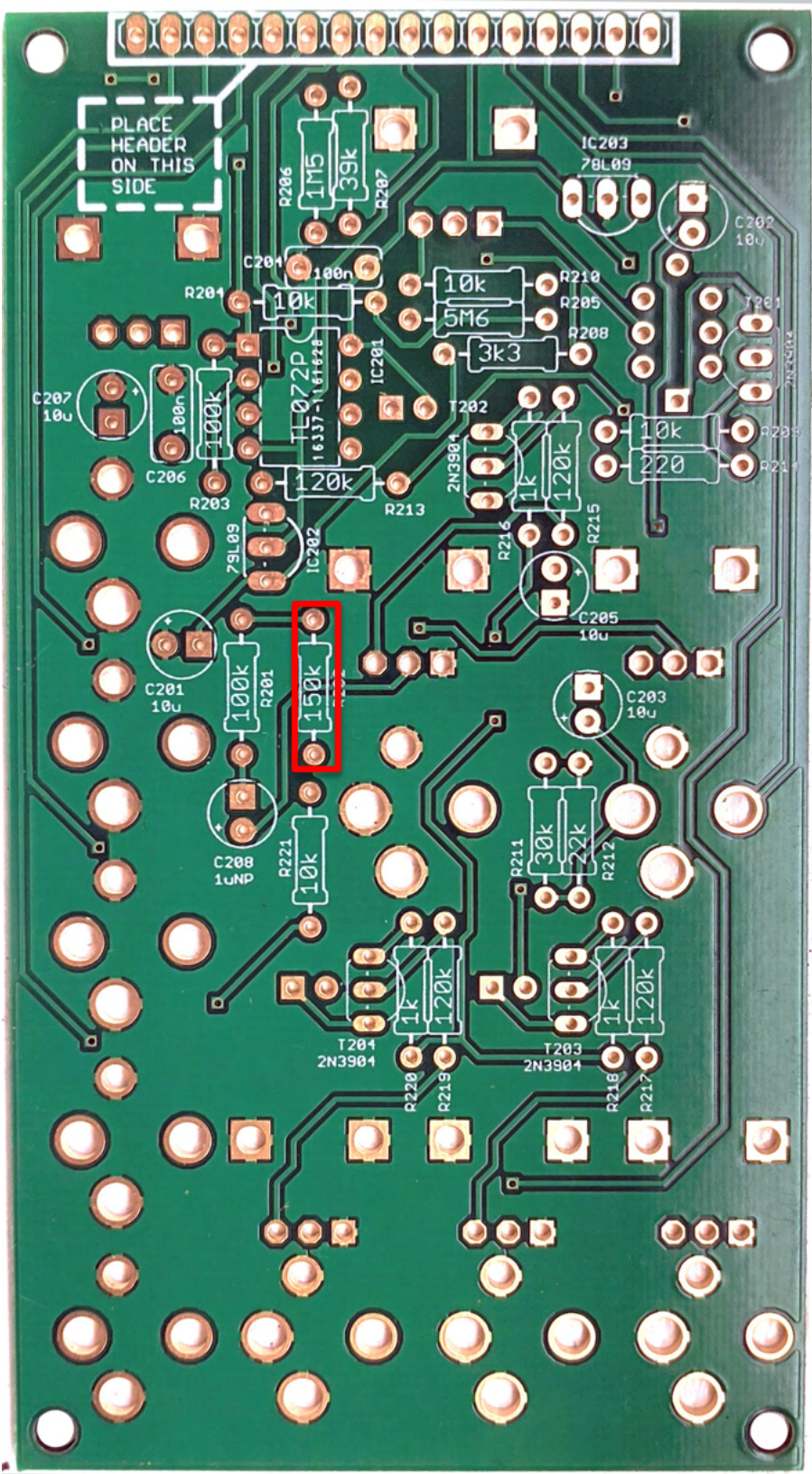

9 – 1 x 150k resistor

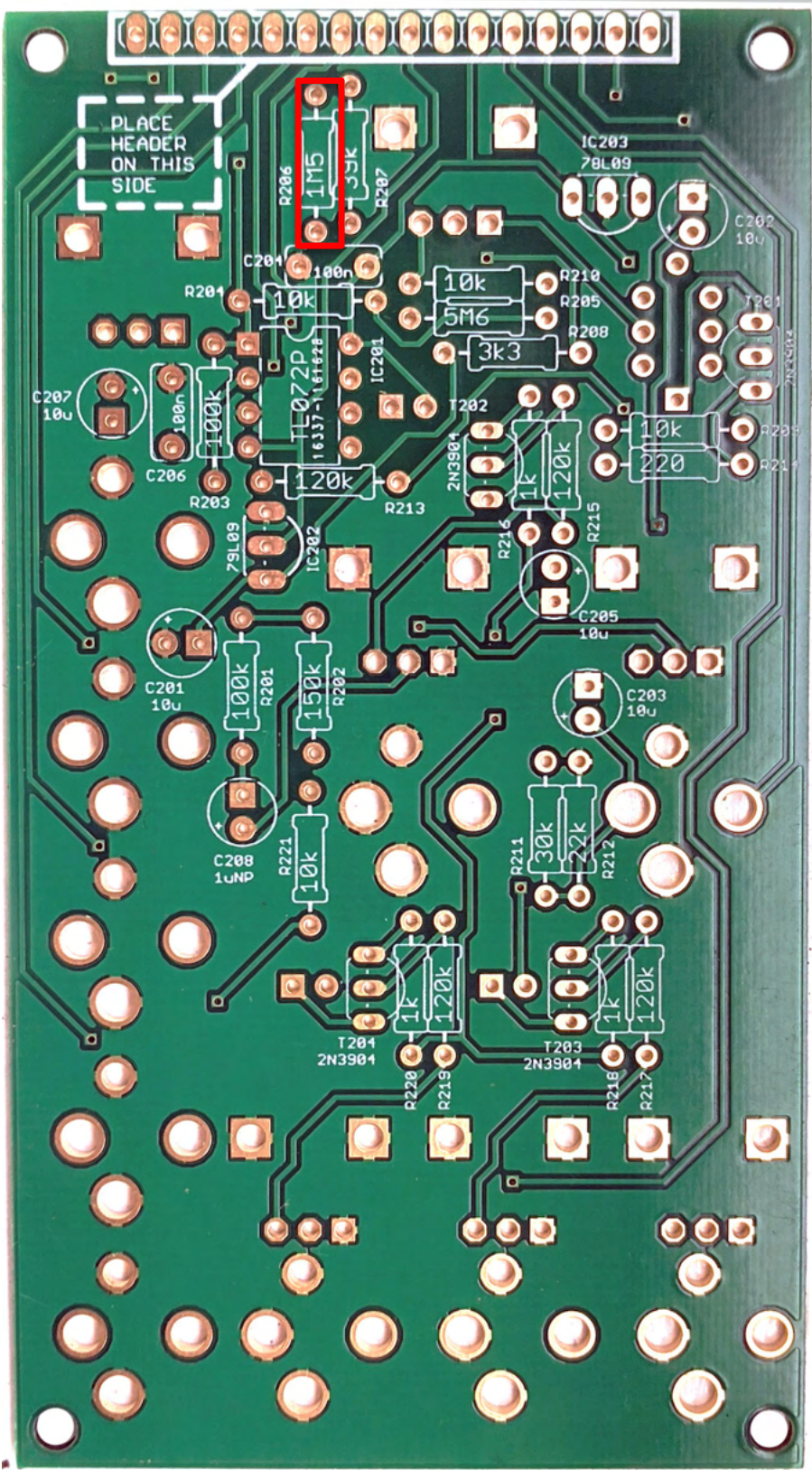

10 – 1 x 1M5 resistor

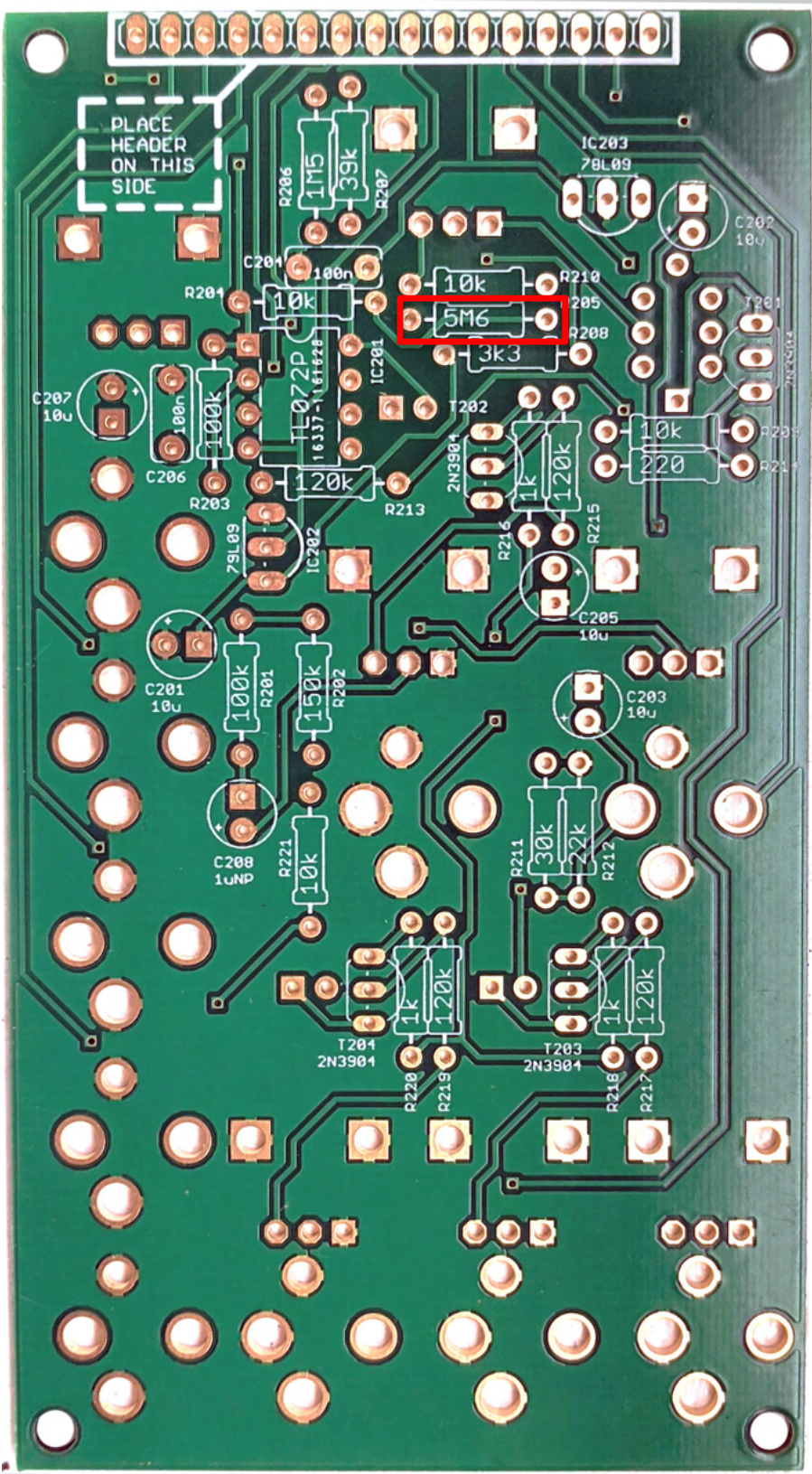

11 – 1 x 5M6 resistor

IC Sockets

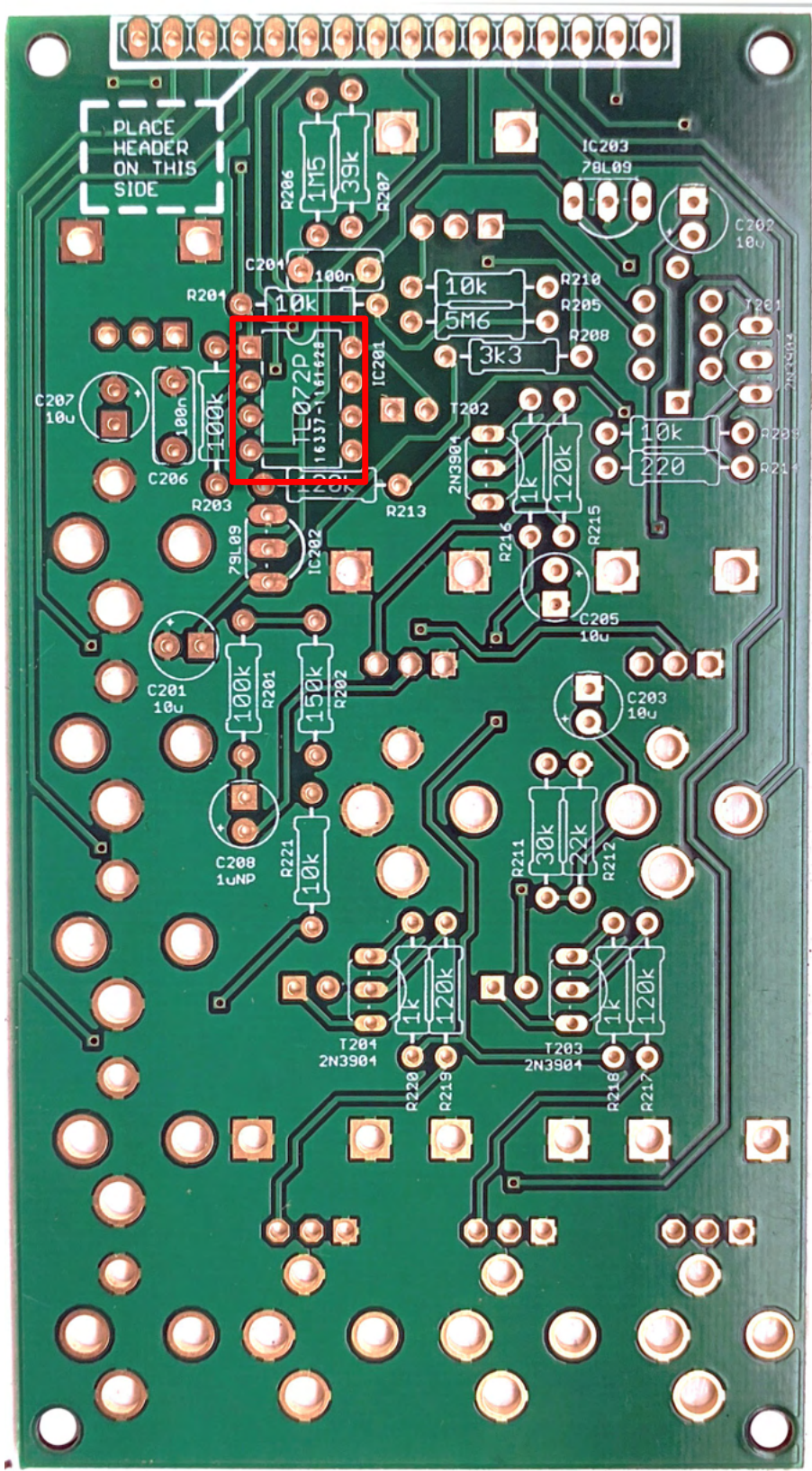

12 – IC socket - Make sure the notch in the socket matches the notch on the silkscreen.

Capacitors

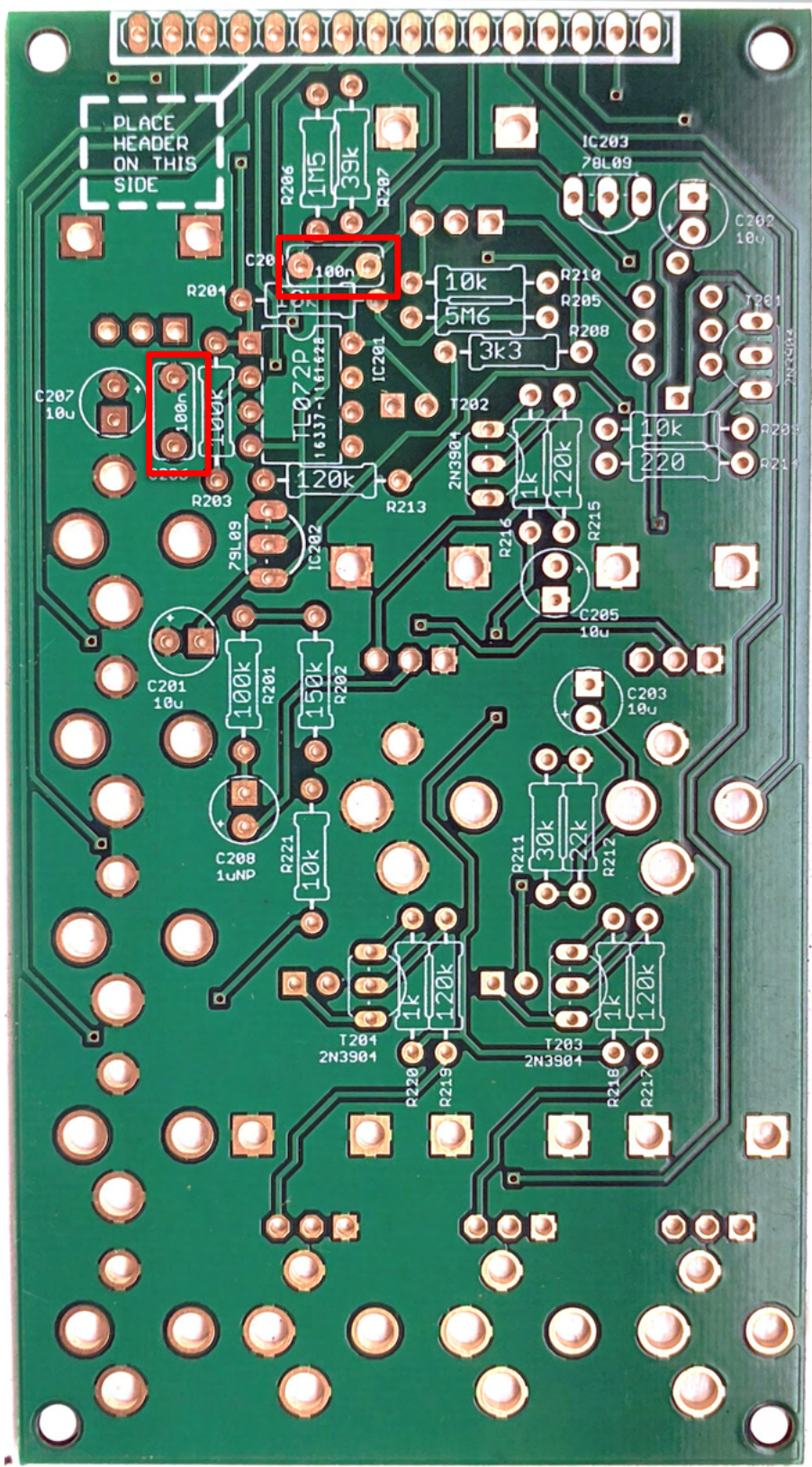

13 – 2 x 100nF capacitors

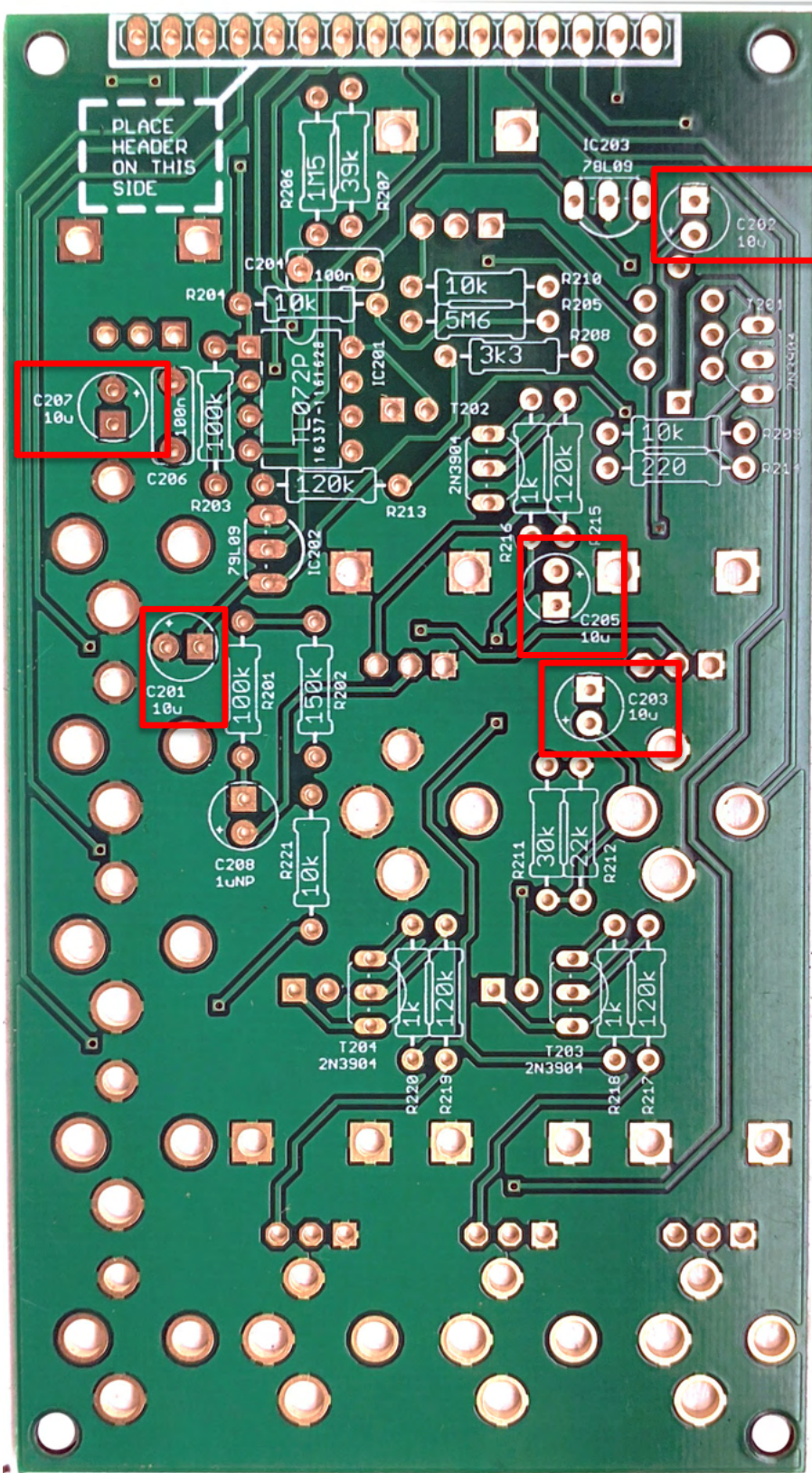

14 – 5 x 10uF capacitors - orientation is vital, the longer lead on the component should go to the circular pad marked with a plus '+' on the PCB. Note the component has a grey stripe on the cylindrical body on the minus side.

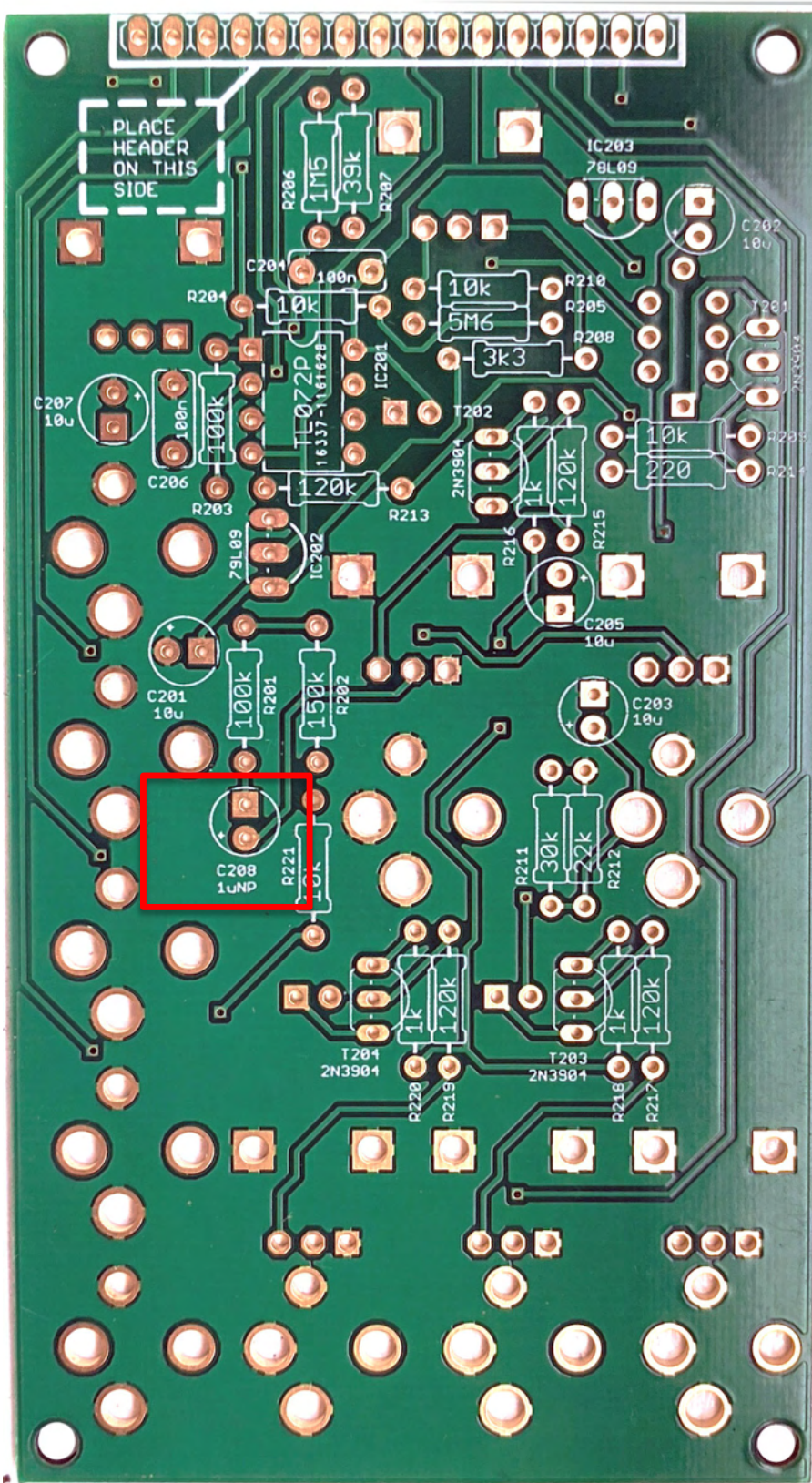

15 – 1 x 1uF NP capacitor. This electro capacitor is non-polar so orientation does not matter.

Transistors

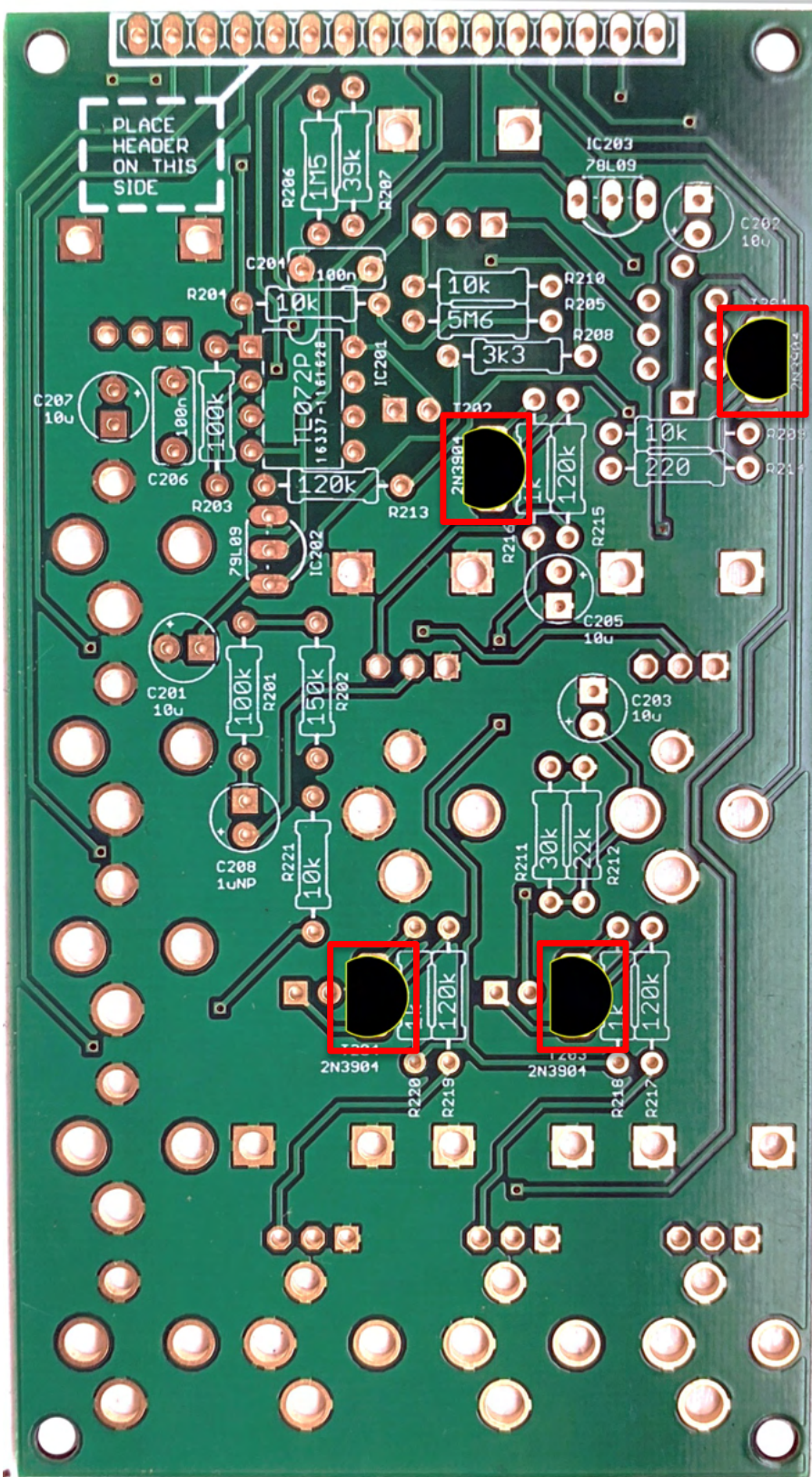

16 – 4 x 2N3904 transistors - Ensure the flat face on the component matches the flat face on the PCB silkscreen. Orientation is vital.

Be careful to individually identify all the transistors, there are many different types to separate, make sure what you have matches the label on the transistor bag.

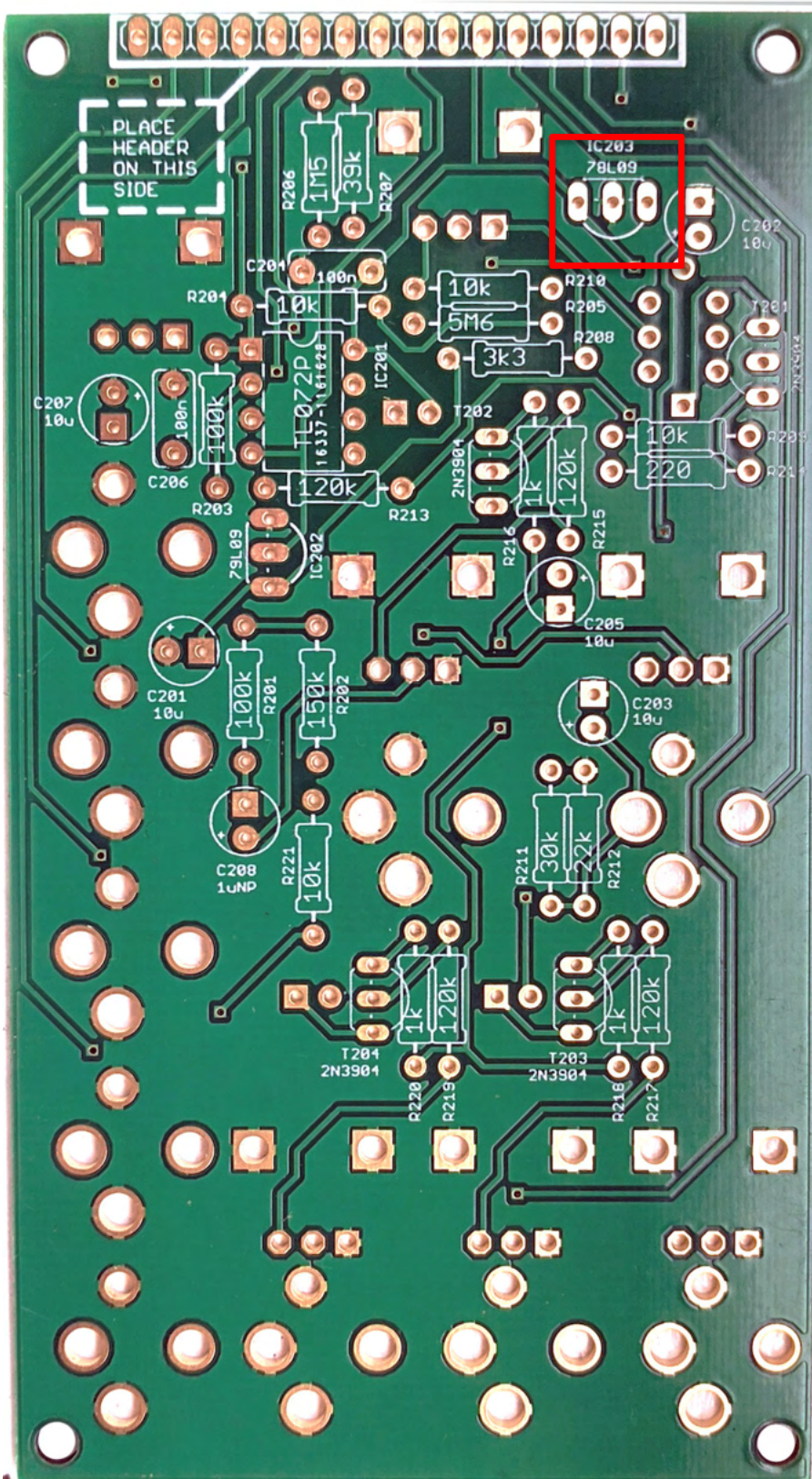

17 – 1 x 78L09 transistor - Ensure the flat face on the component matches the flat face on the PCB silkscreen. Orientation is vital.

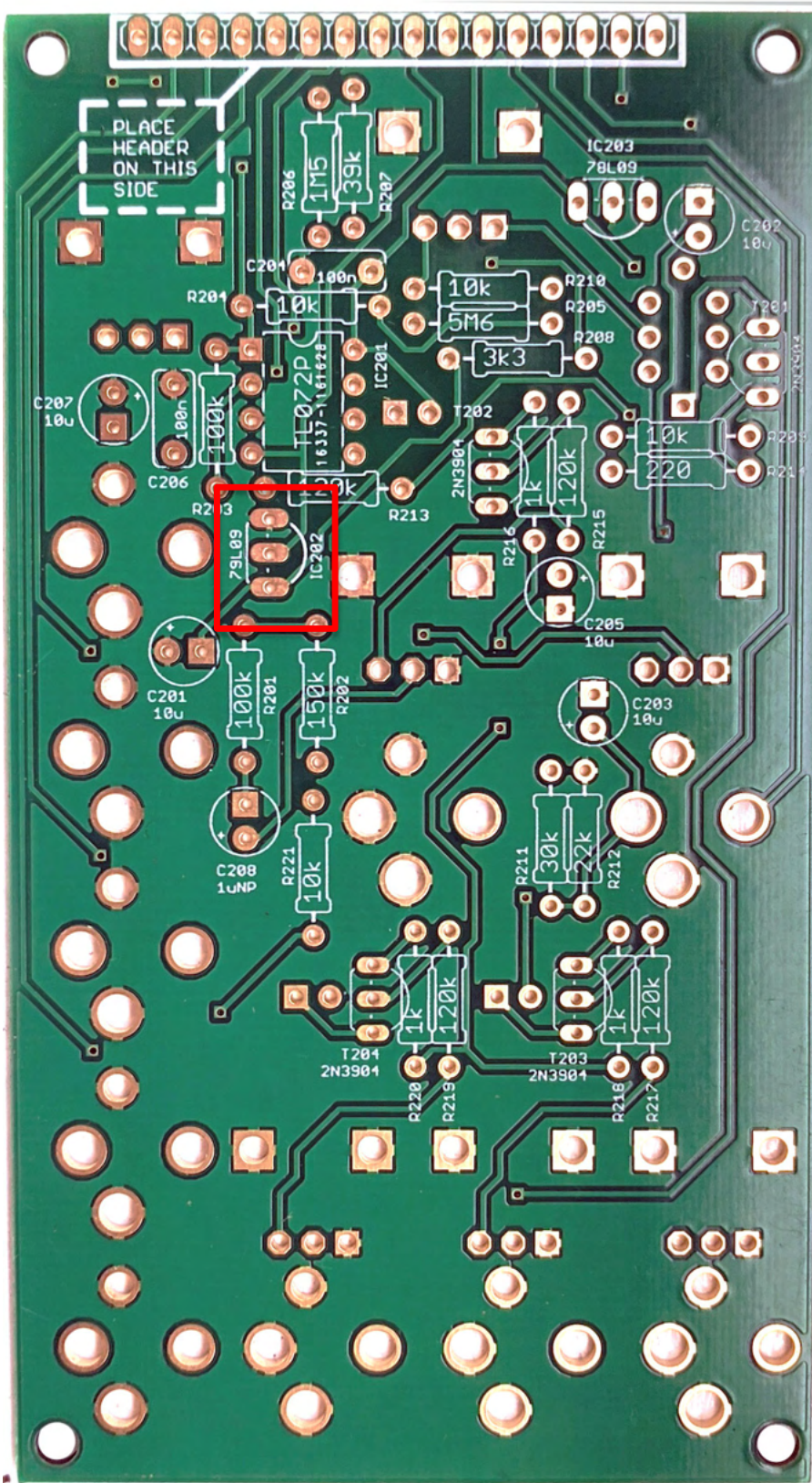

18 – 1 x 79L09 transistor - Ensure the flat face on the component matches the flat face on the PCB silkscreen. Orientation is vital.

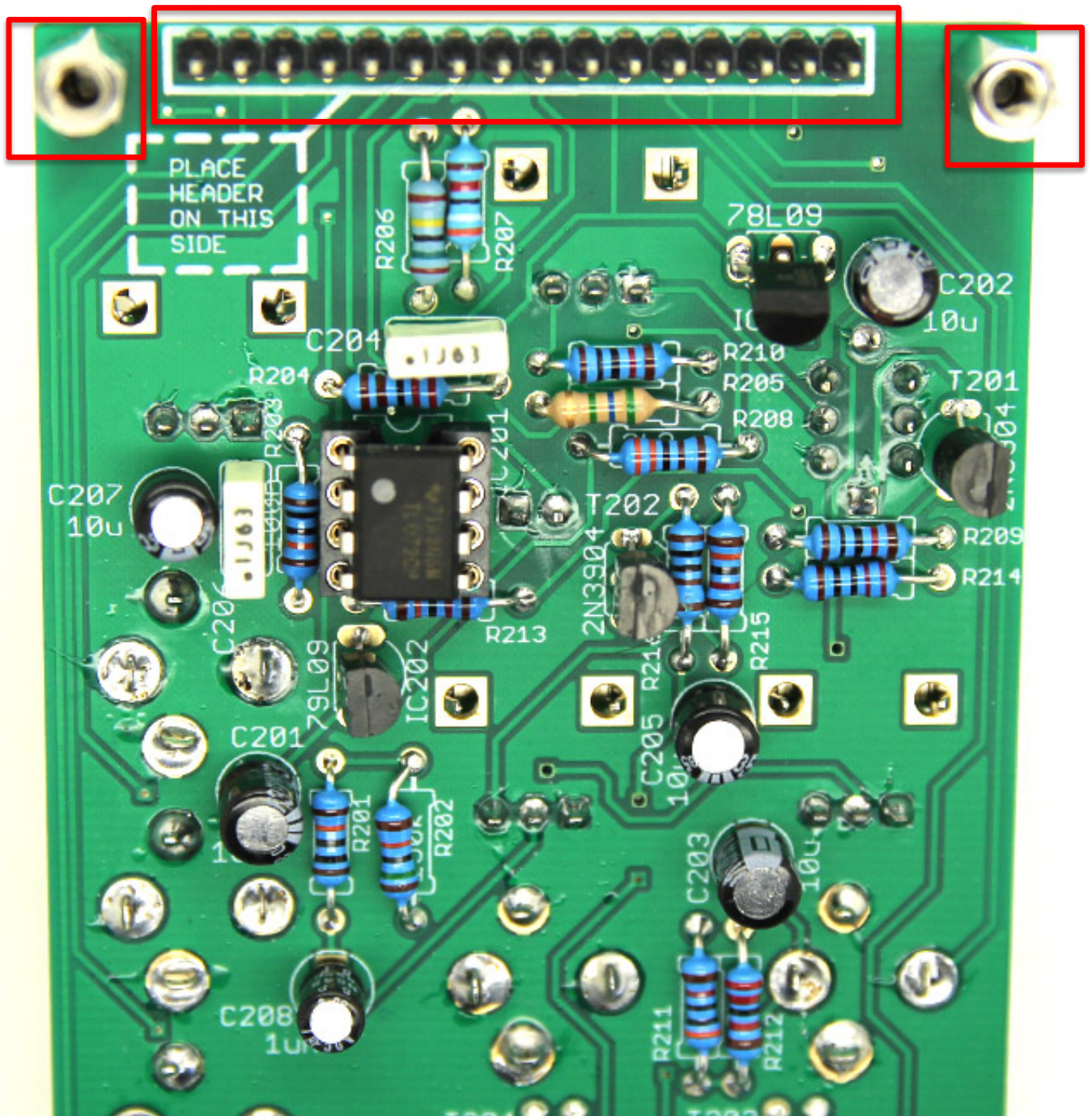

19 – 1 x SIL pin male header – now is also a good time to screw the four hex standoffs onto the front PCB

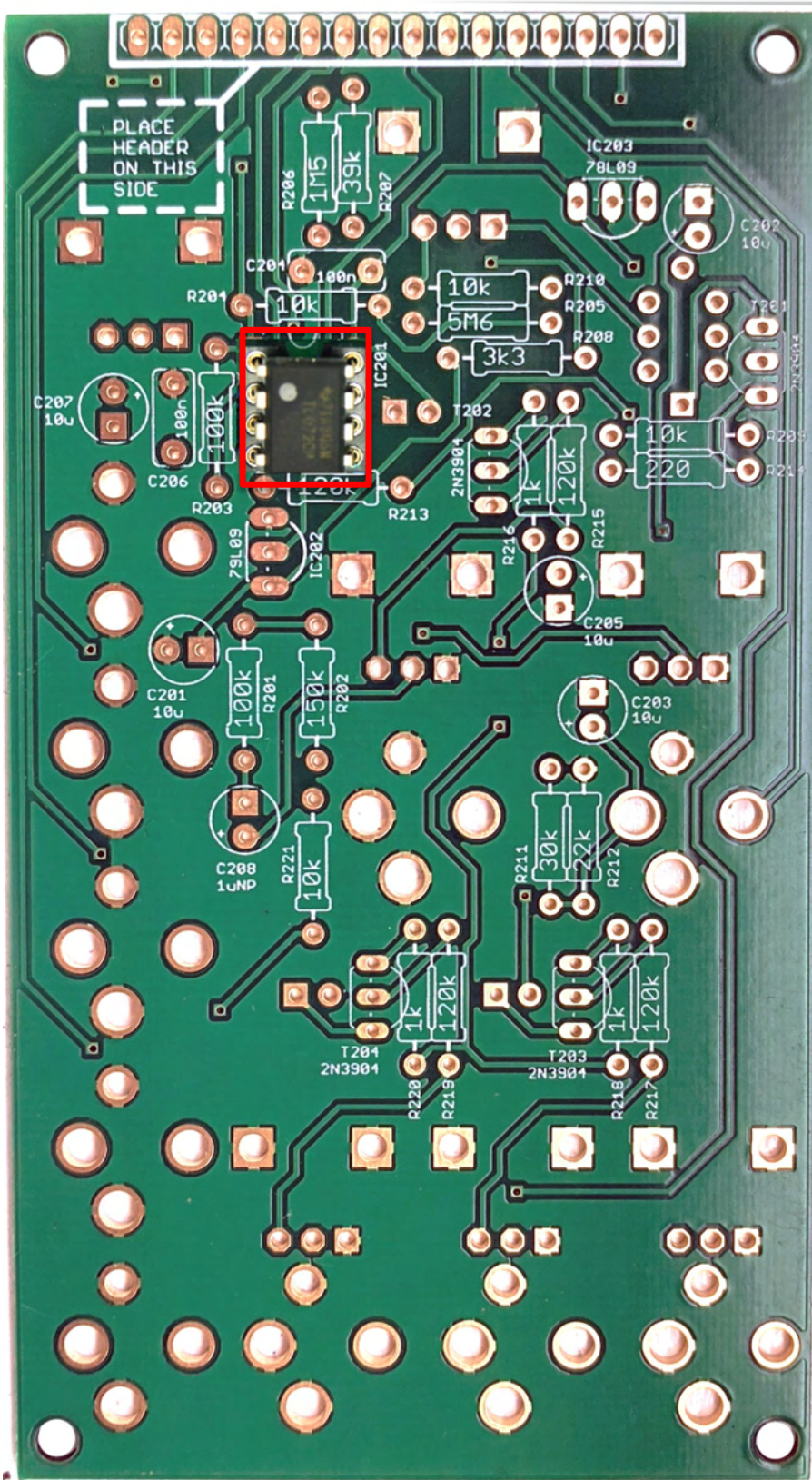

20 – 1 x TL072 opamp - orientation is vital, match the dot with the notch on the PCB silkscreen and IC Socket

Panel Components

These components should be inserted but NOT SOLDERED until the panel has been placed on top. This is to ensure that the PCB fits the panel properly.

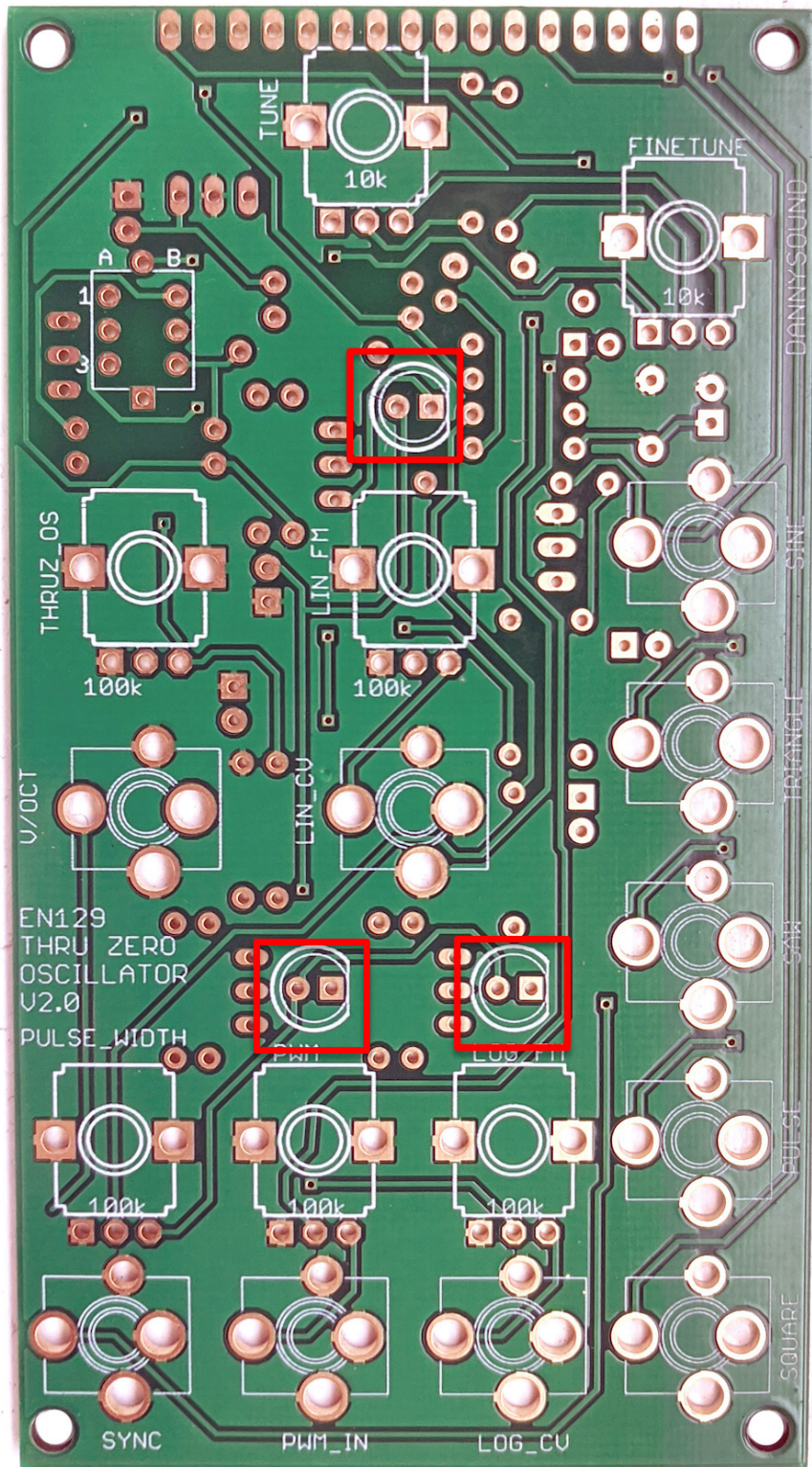

21 – 3 x LEDs - orientation is vital, the shorter leg of the LED should go to the square pad and flat side of the PCB silkscreen diagram.

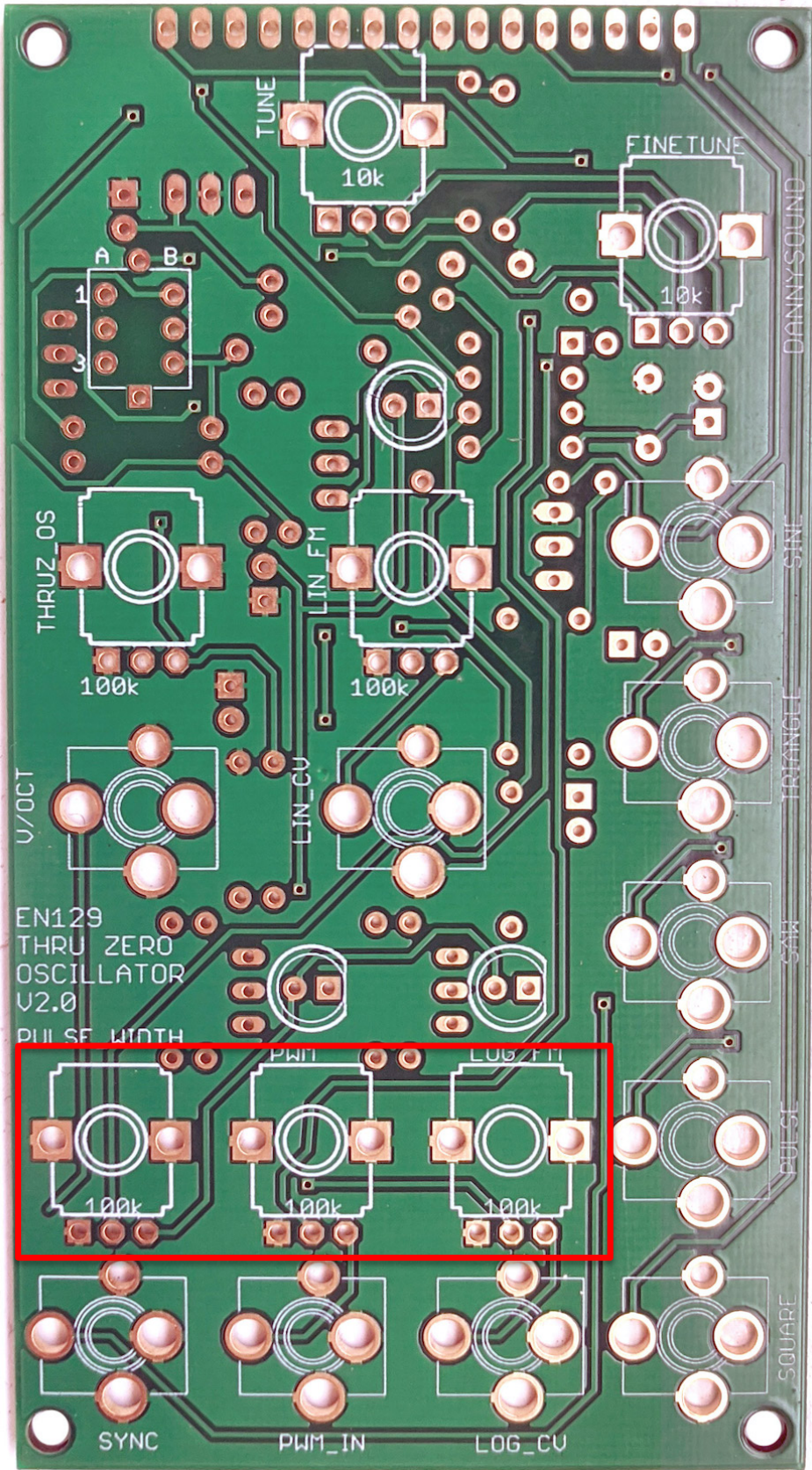

23 – 3 x B100k blue body plastic shaft pots



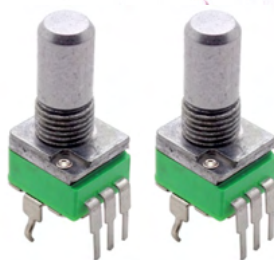
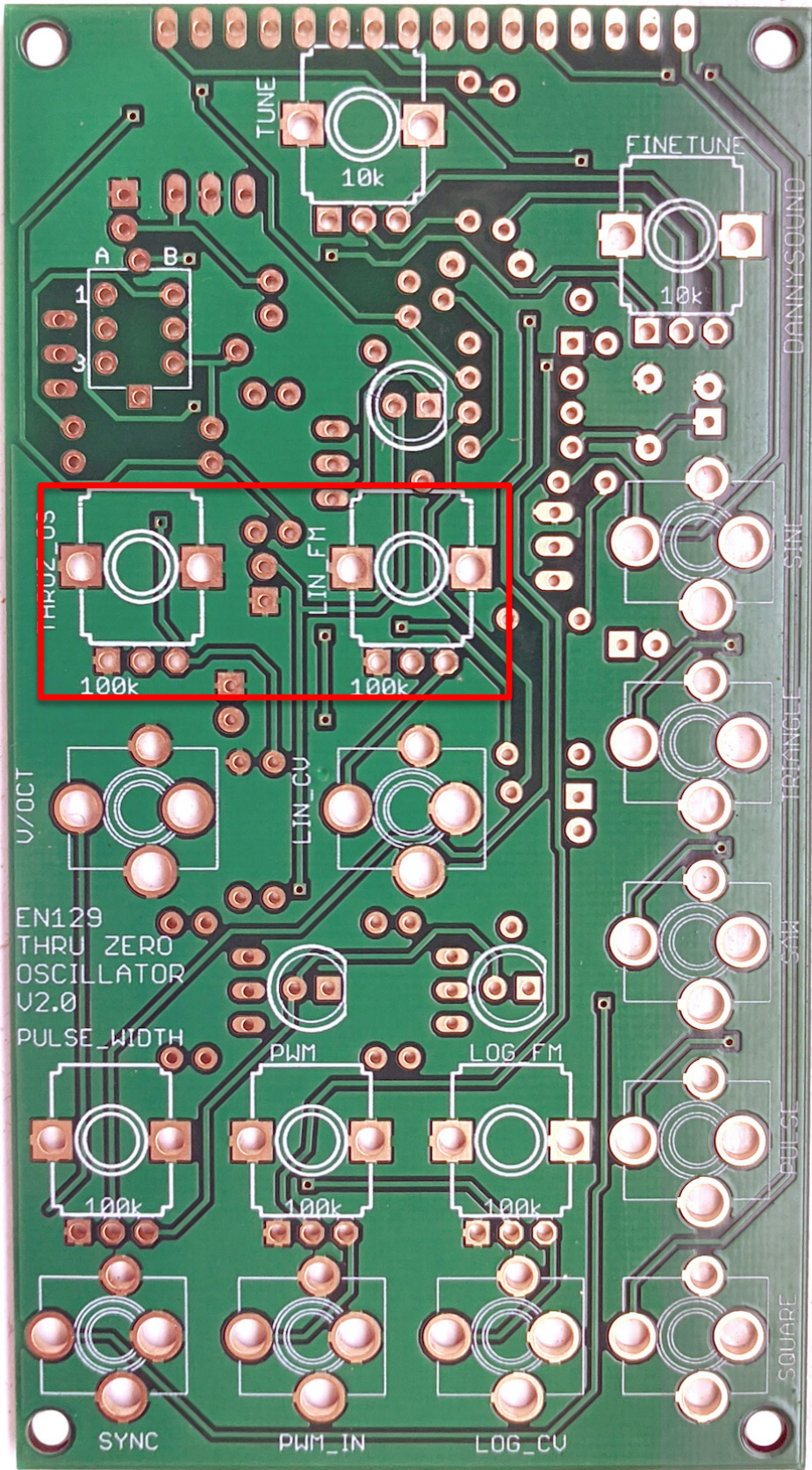

24 – 2 x **B100K** green body metal shaft pots

B100K

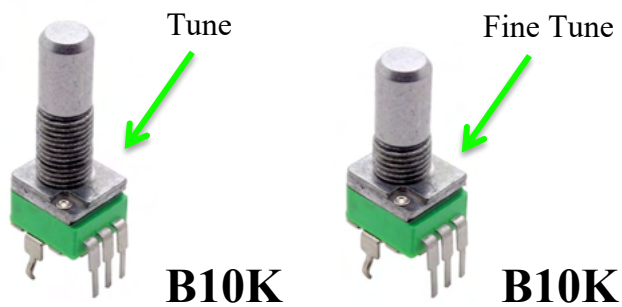
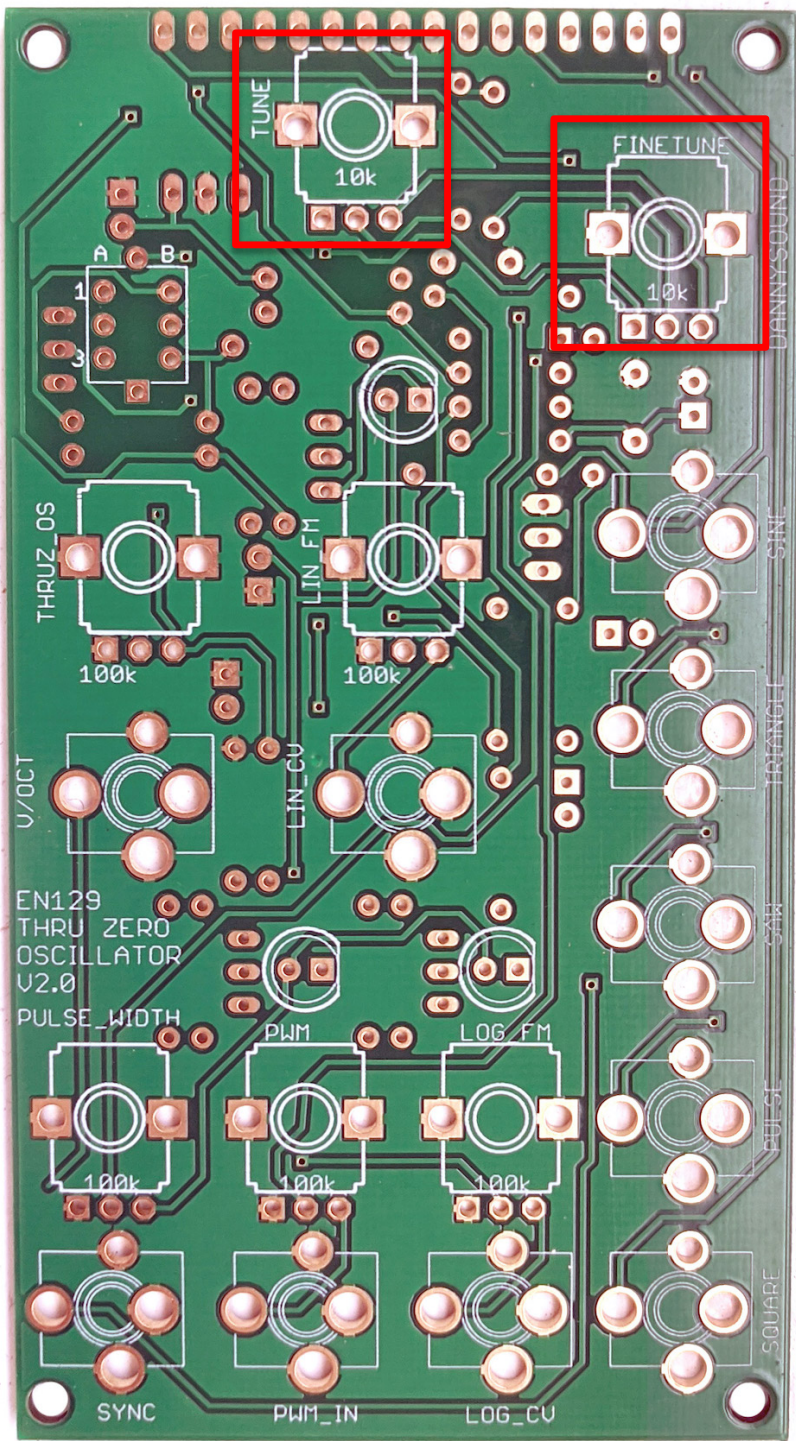

25 - 2 x 10k linear alpha pots

B10K

B10K

Note: The longer shaft B10K pot this must go in the Tune position

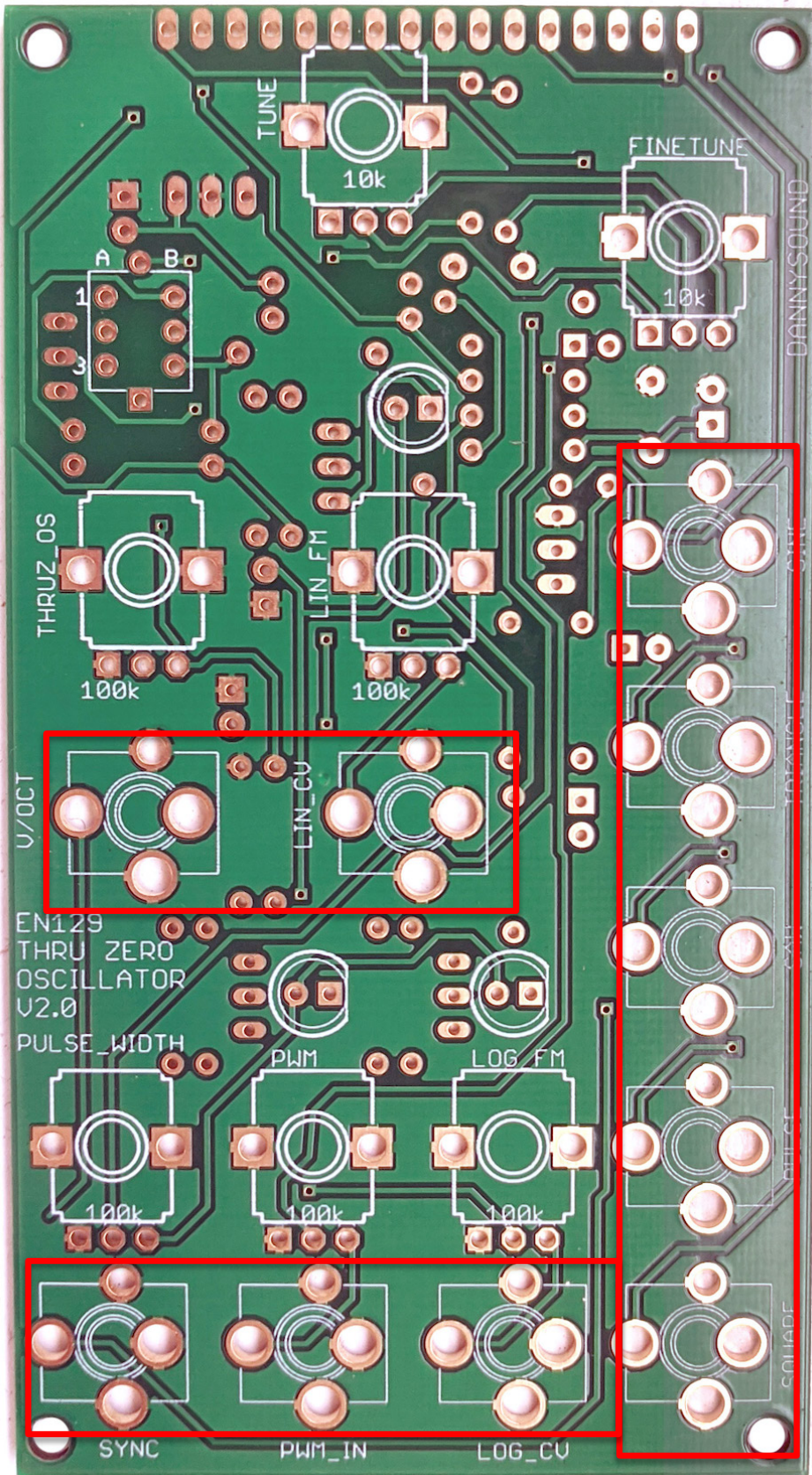

26 – 10 x jack sockets

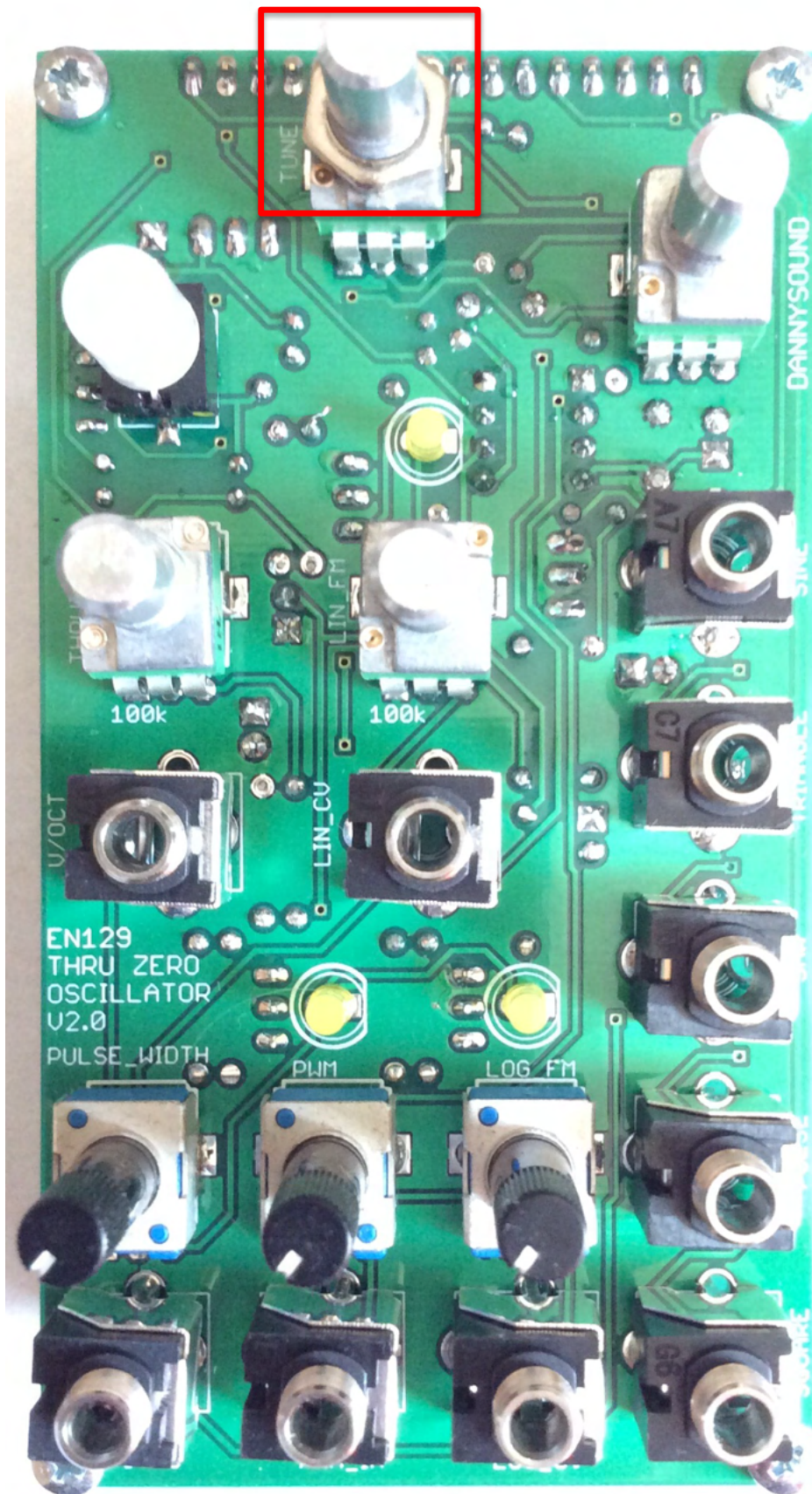

27 – Insert 1 x pot nut – this nut will sit below the panel

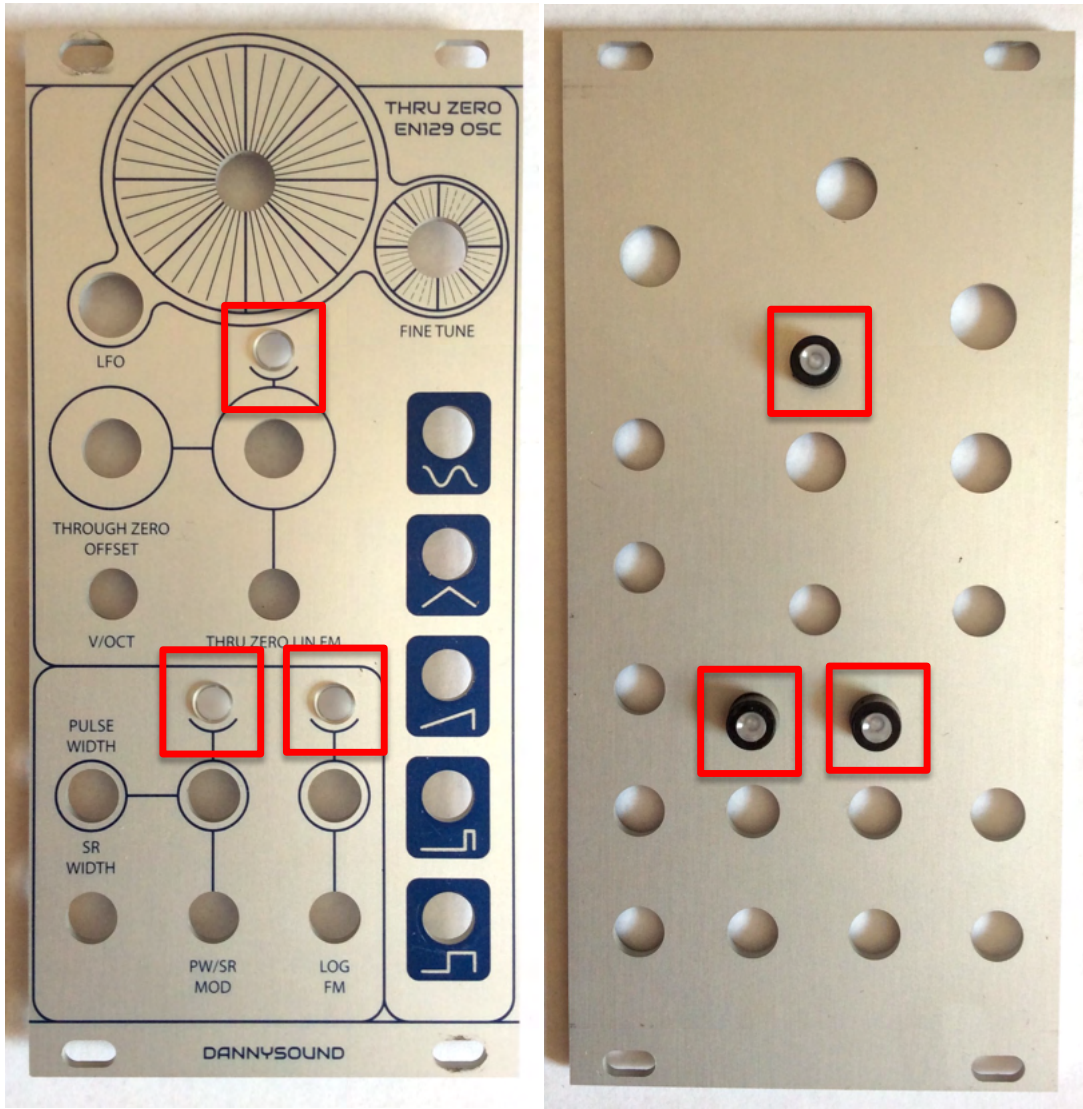

28 – Insert LED light pipes and retainer clips





29 – Fit the panel and insert second pot nut but do not fully tighten.



30 – Centre the knob with the panel graphics then remove the knob and tighten the nut. Now replace the knob again - screwing on with the supplied larger hex key. Note: be sure that the knob isn't scraping against the panel. Inserting a piece of folded paper or thin card between the knob and the panel can help you ensure a small clearance between them.

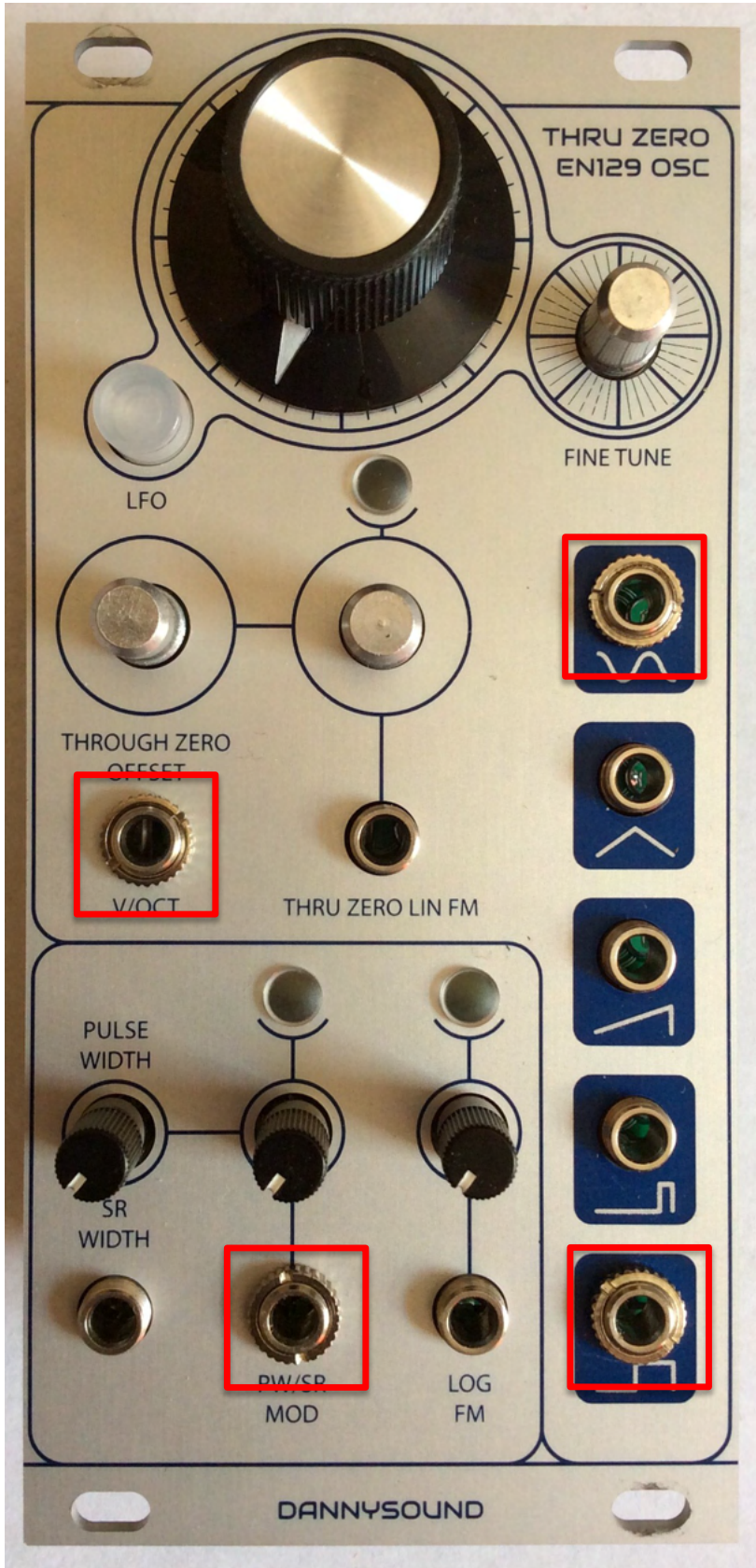

31 – Solder one pin on each of the four outer jack sockets then add nuts to keep panel in place.



33 – Add knobs and solder one ground tab of each pot.

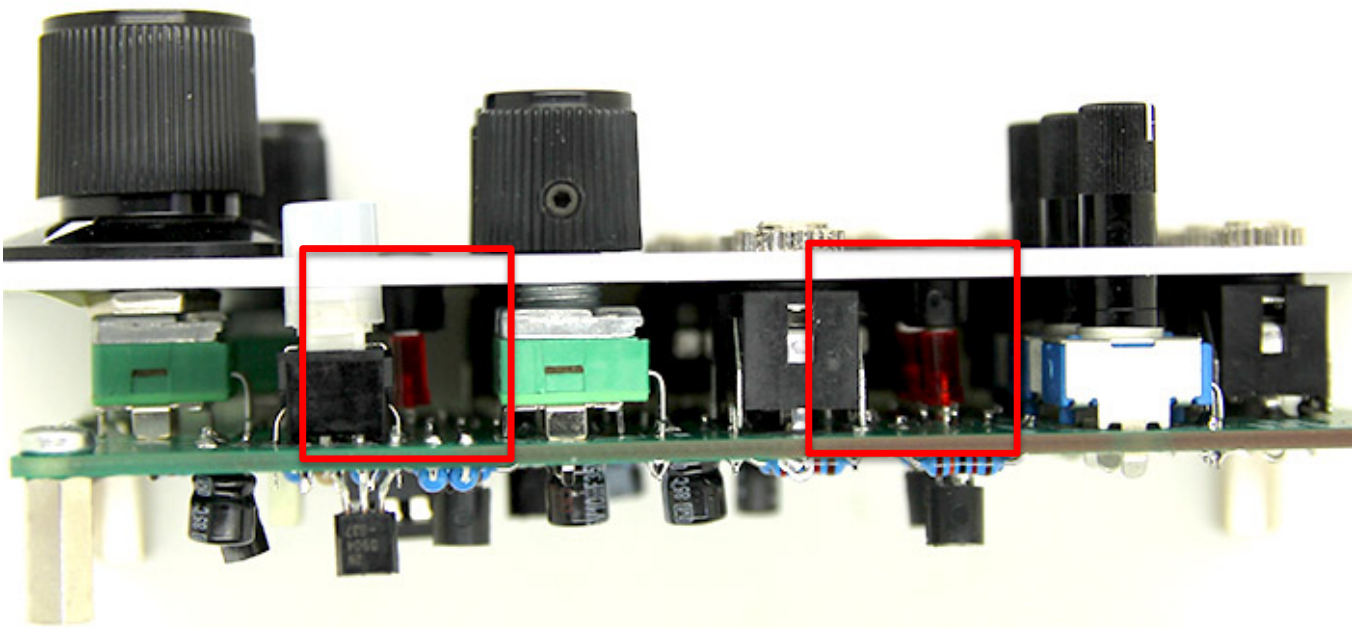

34 – Solder the LEDs in place making sure the LEDs are lined up and touching the light pipes. Check panel components are lined up properly and then solder the rest of the component pins on the PCB.

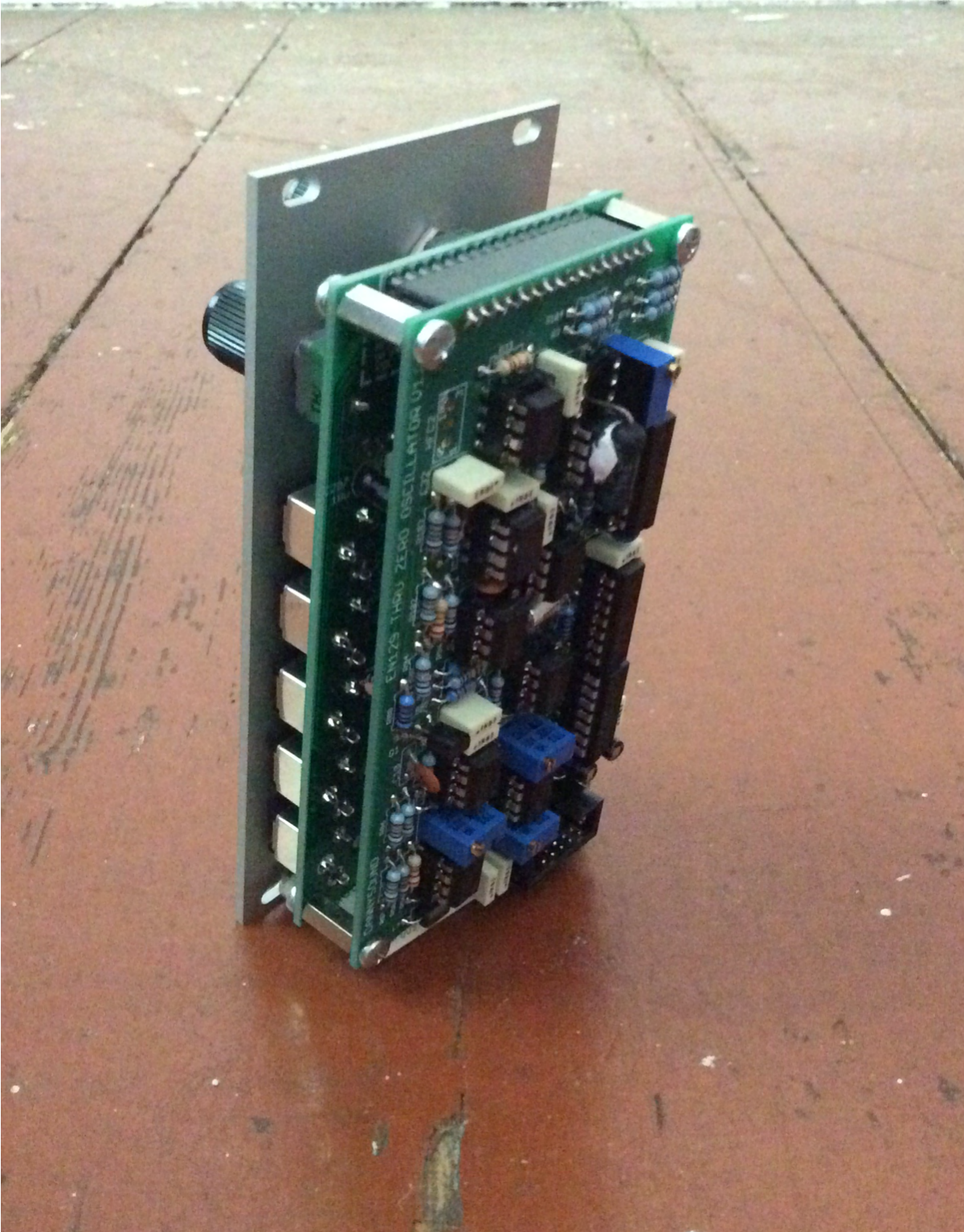

35 – Add PCB mounting hardware, connect the main board and insert the remaining screws.

Calibration

This procedure requires an oscilloscope.

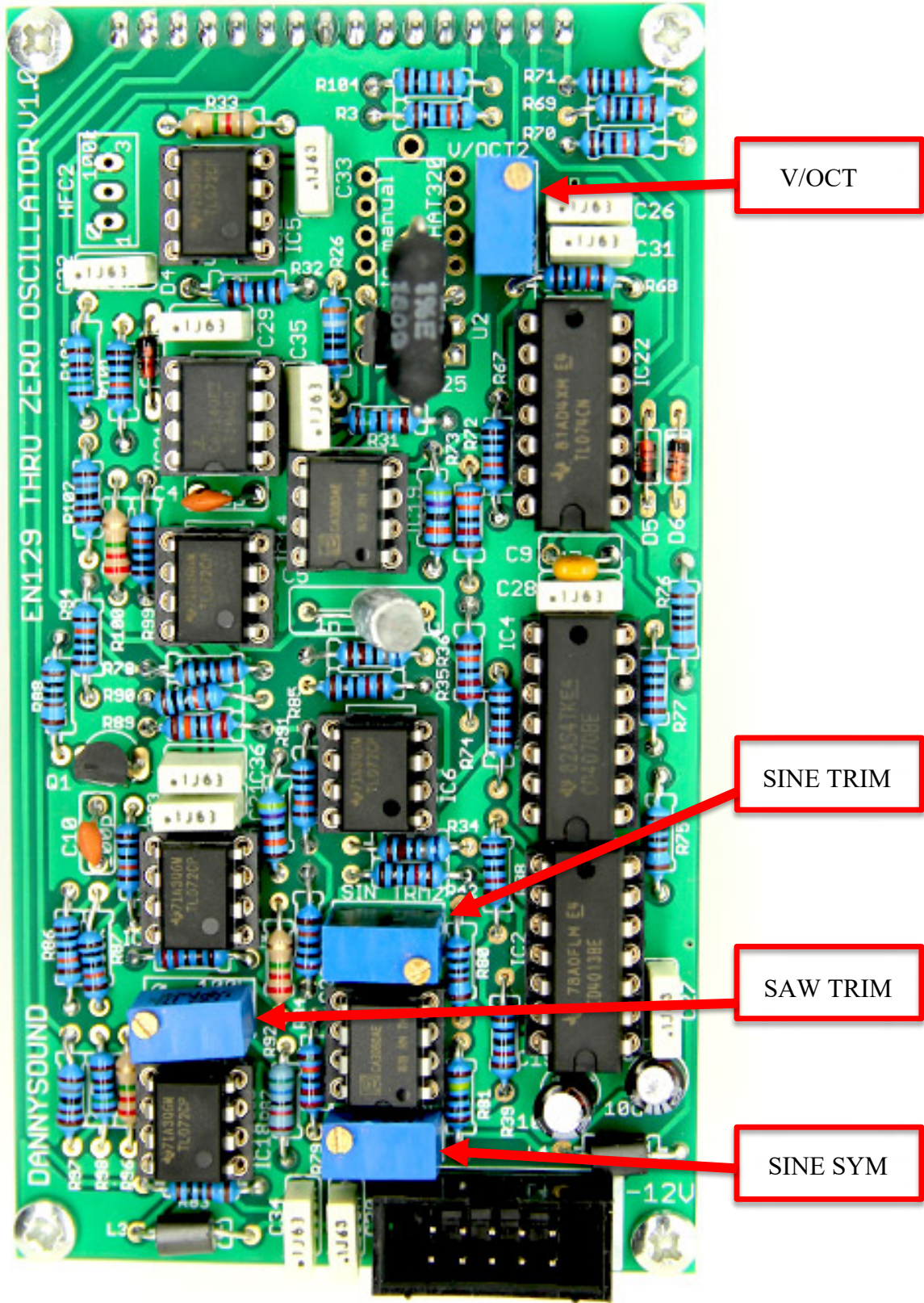

V/OCT

SINE TRIM

SAW TRIM

SINE SYM

1 – Sine Symmetry

Set the Frequency and Through Zero Offset controls to 50% and all other controls to 0. Connect the SINE output to the oscilloscope. Ensure the scope trace is centered.

1 – If the wave looks more square than triangle then adjust SINE TRIM to obtain more of a triangle wave shape.

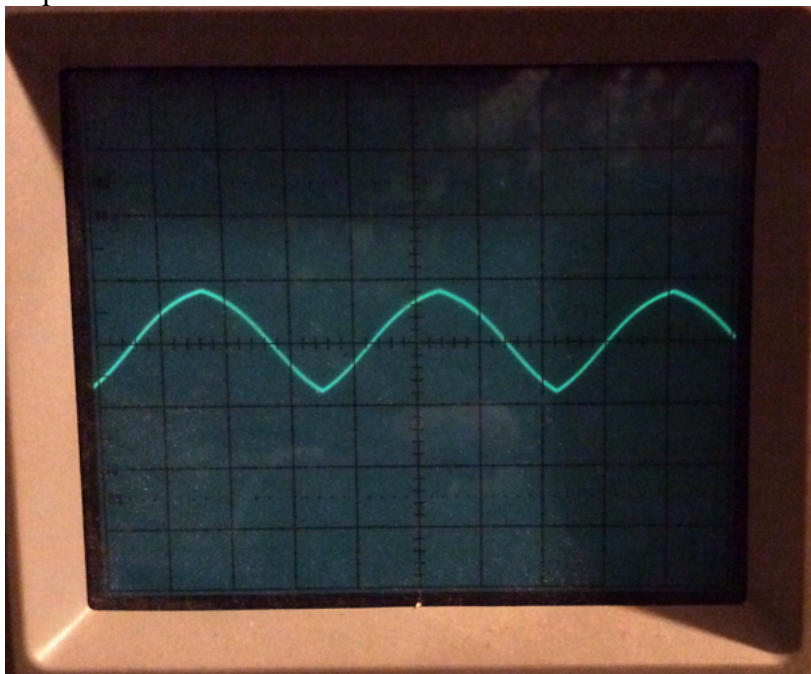

2 – Adjust SINE SYM to produce a symmetrical waveform with no dc offset.

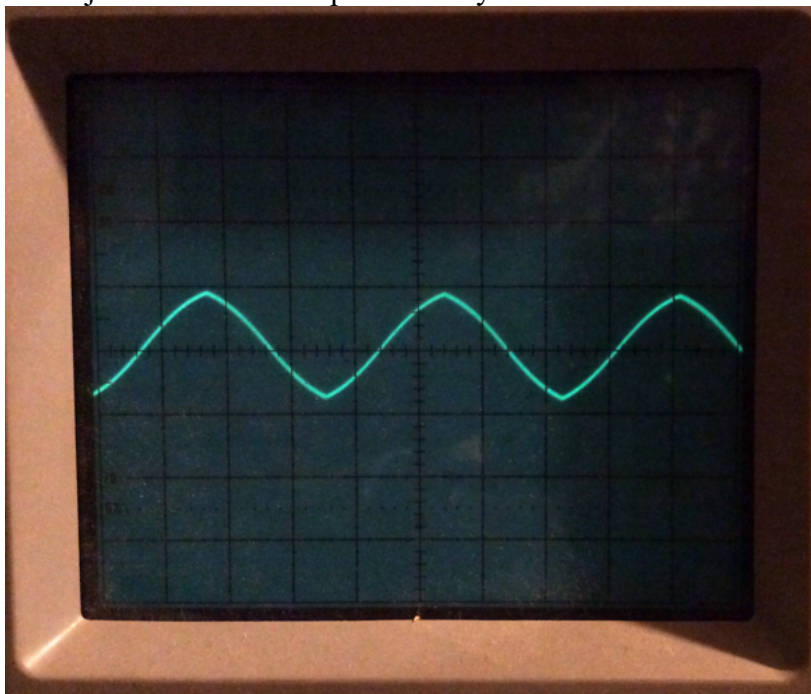

2 – Sine Trim

Adjust SINE TRIM again to produce a sine wave shape. If possible it's a good idea to listen to the oscillator when making this adjustment as you might prefer a more rounded sine wave.

1 – Pure sine wave.

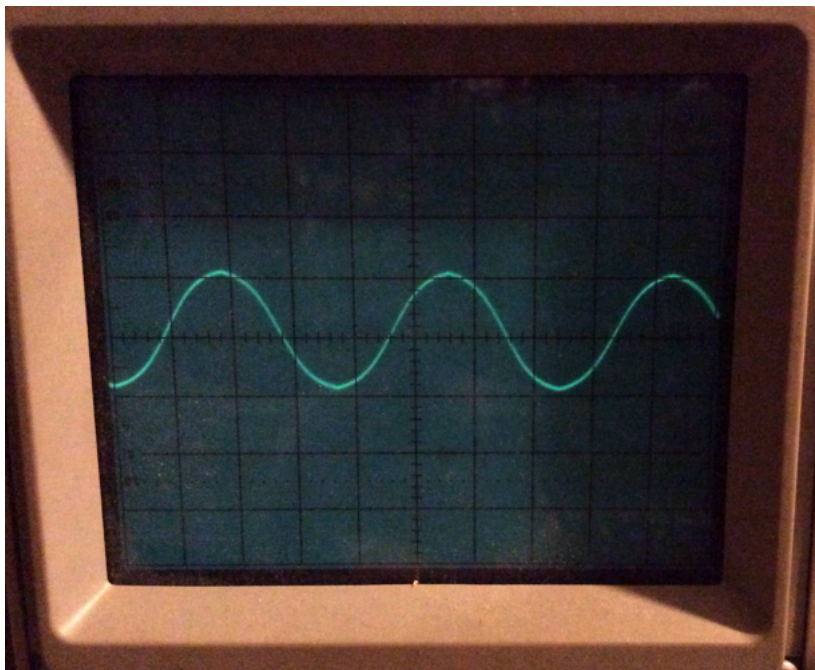

2 – Rounded sine wave.

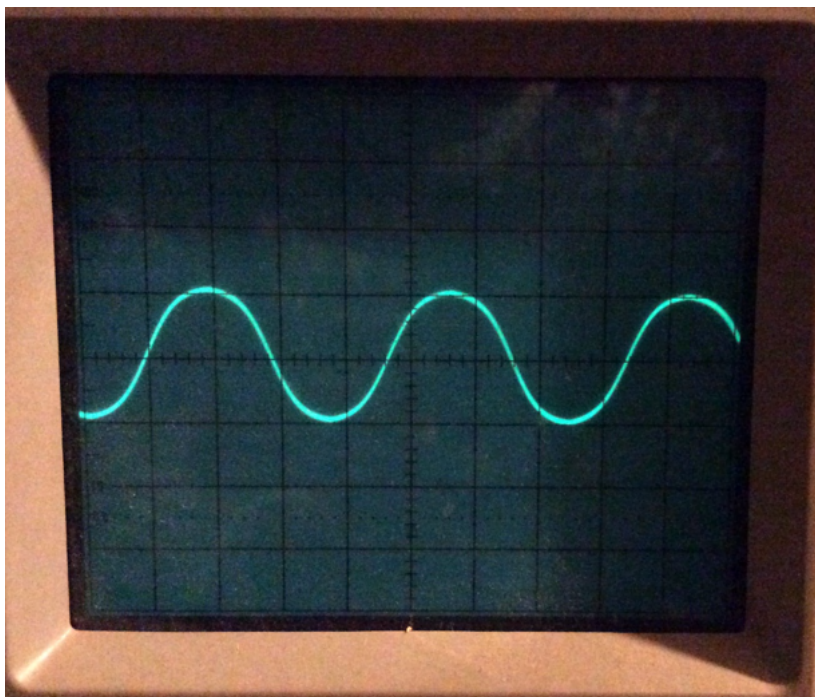

3 – Saw Trim

Connect the oscilloscope to the SAW output.
Adjust SAW TRIM to obtain a saw wave.

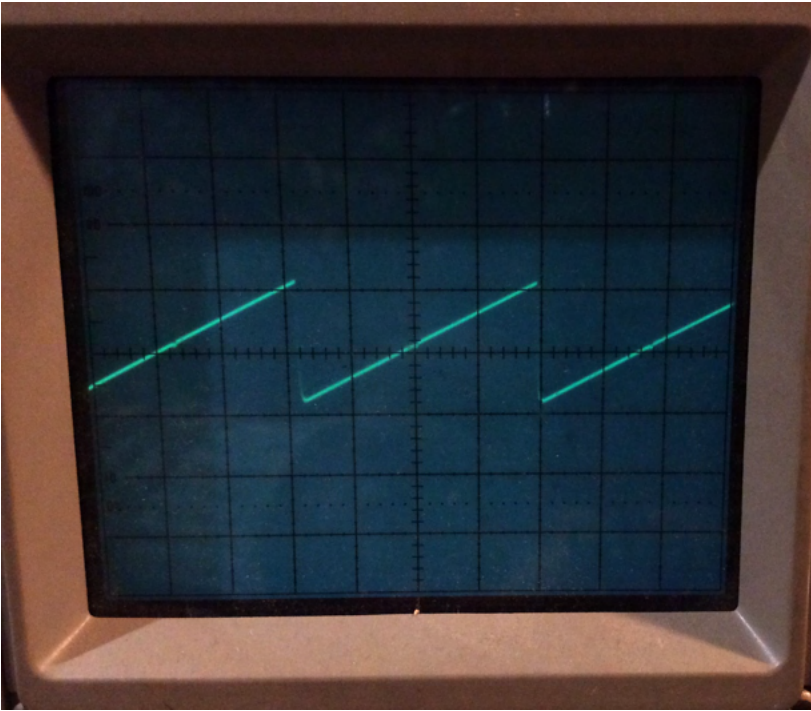

V/OCT CALIBRATION

The V/OCT calibration can be done using a guitar tuner or by listening if you have a good sense of pitch!

- 1 – Connect the SINE output to either an amplifier or a tuner.
- 2 – Connect voltage source / keyboard to V/OCT input.
- 3– Send 3V (C1) from voltage source / keyboard.
- 4– Adjust front panel frequency control to produce note C1.
- 5 – Send 7V (C5) from voltage source / keyboard.
- 6 – Adjust V/OCT trim pot and repeat steps 4 to 6 until the interval between the two notes is 4 octaves.

The optional HFC trim pot (not included in Thonk kit) is for high frequency correction, where the oscillator pitch tracks fine up to a certain point then starts to get flatter in the higher frequencies.

In practice I've never had to use this as the oscillator tracks fine. However, if you do experience this phenomenon then install and adjust an HFC trim pot to correct for it. Start with the trim pot fully anti-clockwise (reverse direction if your trim pot is inserted the other way around to the photo below).



Modifications

The LED brightness can be adjusted by changing the values of R218, R220, R216 and R214 for the PWM, LOG FM, LIN FM and LFO switch respectively.

Higher resistance = less brightness

The Range for the main frequency and fine frequency can be increased or decreased by adjusting the values of R207 and R206 respectively. Higher resistance = more limited range.