

DGVSW 350 ST T3



Measures:

L: 4600 mm H: 2235 mm
W: 1550 mm

Weight (dry):

10251 lbs / 4650 kg

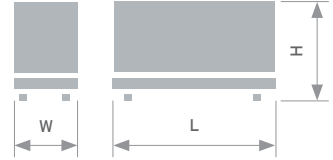

60Hz



Diesel



Water cooled



Soundproofed



1800 RPM



CSA Approved or Equivalent

1 Genset General Description

> Soundproof genset with automatic startup, control card allows automatic, manual or signal start-up.

General Technical Data			
Engine	VOLVO TAD 1352 GE		
Alternators	240/120V	Wdg.	STAMFORD HCI544F-w311
		311-1ph	
	208/120V	Wdg.	STAMFORD S4L1D-F
		311	
	600/347V	Wdg.	STAMFORD HCI444E
		17	
Performance Class	G3		
Frequency	60Hz		
Control Panel	240/120V	DSE 7320 MKII	
	208/120V	DSE 7320 MKII	
	600/347V	DSE 7320 MKII	
Noise level (dBA@7m)	71		

Voltage (v)	PRP (kW)	ESP (kW)	PRP/ESP (A)
240/120V	295	325	1229/1354
208/120V	322	351	1117/1217
600/347V	323	352	388/423

PRP: Continuous power ("Prime Power") ISO 8528-1 standard.
ESP: Emergency power ("Emergency Standby Power") ISO8528-1 standard.

2 Engine Specifications

- › VOLVO TAD 1352 GE Diesel engine, inline 6-cylinders, 4-stroke. Turbocharged aspiration, air intake system. Electronic regulation. Complying with Tier 3 emissions.

Engine General Data			
Manufacturer/Model	VOLVO TAD 1352 GE	Number of Cylinders	6 cylinders
R.P.M.	1800	Engine Capacity	12,8
Max. Power (kWm) (net)	376	Cooling System	Water cooled
Power PRP (Kwm) (net)	344	Regulation Type	Electronic
Fuel	Diesel	Engine Type/Injection/Suction	Diesel /Direct/ Turbocharged

2.1 Fuel Feed System

- › Direct injection system, fuel filter included that prevents the passage of particles, original parts from the engine manufacturer.

50% PRP	43,8 l/h (11,6 US gals/h)
100% PRP	85,2 l/h (22,5 US gals/h)

75% PRP	64,5 l/h (17 US gals/h)
110% ESP	N/A l/h (N/A US gals/h)

2.2 Cooling System

- › Cooling by fully distributed coolant in a closed circuit driven by a pump activated by the engine. Tropicalized radiator. Original parts from the engine manufacturer.

5,5	25,5 (19)	44	3000W 240V
Fan Airflow (l/s)	Fan Power Consumption, hp (kW)	Engine + Radiator Capacity (l)	Blockheater (W/V)

2.3 Lubricating System

- › Lubrication system is driven by the crankshaft driven pump. Filter on top with full flow cartridge inserted, front crankcase. Original parts from the engine manufacture.

Total Oil Capacity 36L

 With oil pressure reading sensor

2.4 Air Intake System

› Direct air intake system including two-stage filter. Original parts from the engine manufacturer.

Combustion Air Volume 116 l/h

2.5 Start System

› Start system by electric motor. battery (without maintenance) with disconnecter and charging alternator driven by the starter motor 24V, original parts from the engine manufacturer.

Number of Batteries

2

Battery Features

4D-9

Starting Voltage

24V

2.6 Exhaust System

› Attenuation level -35dB(A). Complying Tier 3 Interim emissions.

Exhaust System

Exhaust Gas Volume	62,7 m ³ /min
Exhaust Gas Temperature	535 °C
Exhaust External Diameter	N/A" (N/Amm)
Max. Exhaust Backpressure	8kPa

3 Alternator Specifications

› Alternator STAMFORD 4-poles, brushless, alternator with class H insulation wound at 2/3 pitch and self-excited automatic voltage regulator (AVR).

Alternator General Data	240/120V	208/120V	600/347V
Brand/Model	STAMFORD HCl544F-w311	STAMFORD S4L1D-F	STAMFORD HCl444E
Winding No.	311-1ph	311	17
Voltage Regulator AVR	PMG + MX341	PMG + MX341	PMG + MX341
Voltage Regulator	±1%	±1%	±1%
ESP Power Rating 40°C (kW)	324,5	388	368
PRP Power Rating 40°C (kW)	295	364	352
Number of Phases	1	3	3
Power Factor (cos φ)	1	0,8	0,8
Efficiency at 100% Load	94,1%	93,4%	93,5%
Efficiency at 110% Load	94,1%	93,0%	93,3%

The alternator complies with the following standards:

- Class H temperature rise 125°C (257°F), Standby (ESP).
- Class H temperature rise 105°C (302°F), Prime (PRP).
- AS 1359
- IEC 34-1
- BS EN 60034-1
- VDE 0530
- BS 5000
- CAN/CSA-C22.2-100
- NEMA MG1-32

Low wave distortion: THD (100% load) = 2%, THF < 2%, Complying with EN61000-6-3, EN61000-6-2 standards on radio interference.

V.3-2021 • Last update: 04/05/2021 | Page 3

4 Bench Specifications

- › Engine and alternator mounted on a high strength steel frame and painted with electrostatic epoxy polyester powder paint. Frame is tested in saline mist chamber to conform to ASTM B-117-09 for 500 hours. Engine and Alternator are mounted on rubber isolators to help dampen vibration while running.



5 Canopy Specifications

- › Canopy made of high strength galvanized steel and is painted with electrostatic epoxy polyester paint. Canopy is lined with acoustical/fireproof rock wool. A residential exhaust muffler -35dB(A) is installed to dampen exhaust noise. All is tested in a saline mist chamber to conform with ASTM B-117-09 for 720 hour.



6 Control Panel

- › The control panel protects the engine and generator and allows for manual and automatic control of the genset.



6.1 Main Line Breaker

- › Main line circuit breaker: A thermo-magnetic breaker provides protection against short circuits and overloads.

240/120 1600 Amps, Adj.

208/120 1200 Amps, Adj.

600/347 600 Amps, Adj.

6.2 Control Panel Features

- › **Emergency Stop Push Button**

- › **DeepSea Battery Charger**

Permanently connected to the battery to keep the battery fully charged. Charger is equipped with a float feature to keep battery ready in a prime starting state.

- › **Panel Fusing**

Fusing to protect the control panel wiring and accessories.

6.3 Control Card

Control card for 600/347V: DSE 7320 MKII

Features of the DSE 7320 MKII Card:

- 132X64 pixel illuminate LCD display
- Full engine/alternator parameter and alarm read out
- 5-button menu navigation
- One touch Auto-Manual-Test and Stop buttons
- 9 factory configurable outputs
- 8 factory configurable inputs
- Programmable PLC for custom application
- Remote communication through an RS232 or RS485 connection
- Utility sensing Option

The control card complies with the following environmental tests:

- BS EN 61000-6-2 (electromagnetic compatibility)
- BS EN 61000-6-4 (electromagnetic compatibility)
- BS EN 60950 (electrical safety)
- BS EN 61000-6-2 (Temperature)
- BS EN 60068-2-6 (Vibration)
- BS EN 60068-2-30 (Humidity)
- BS EN 60068-2-27 (Shock)

6.4 Display

Control card for all Voltages: DSE 7320 MKII

Engine	
Engine Speed	Engine Hours
Oil Pressure	Number Engine Starts
Battery Voltage	Fuel Consumption
Fuel level	Engine Temperature

Generator	
Voltage (L-N)	Voltage (L-L)
Frequency	Amperage
Power Factor	Load (kW, kVA, kVah)

Mains
Voltage (L-N)
Voltage (L-L)
Frequency

Alarm Detected	
Overcrank	High Engine Temp.
Low Oil Pressure	Low Engine Temp.
Low Coolant Level	Low Fuel Level
Low Plant Battery Voltage	Main Line Breaker
Over Voltage	Over Frequency
Under Voltage	Over Speed
Control Not In Auto	Lamp Test Features
Radiator level sender	

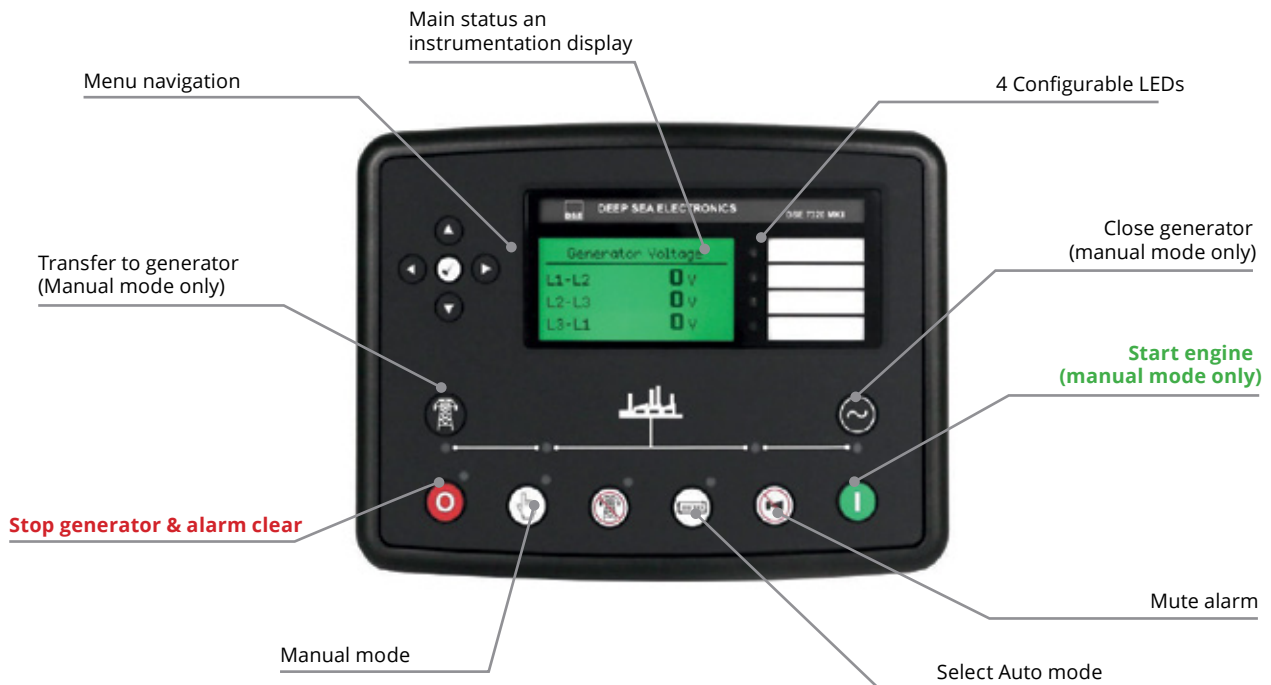

Gensets rated for operational ambient temperature of 40 C, in compliance of CSA C282-15. If ambient temperature exceeds 40 C, please contact sales representative for derating information. Emergency standby power(ESP): the maximum power available for which a genset is delivering in the event of a utility power outage or under test conditions for up to 200hours per year. Prime Power(PRP): the maximum power which a genset is capable of delivering continuously for an unlimited number of hours per year.

One cover exhaust. It can be in both side

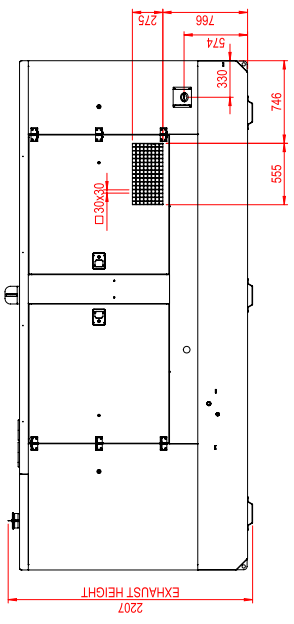
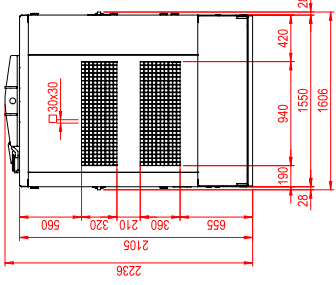
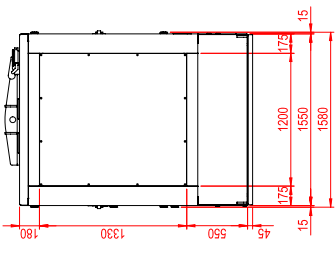
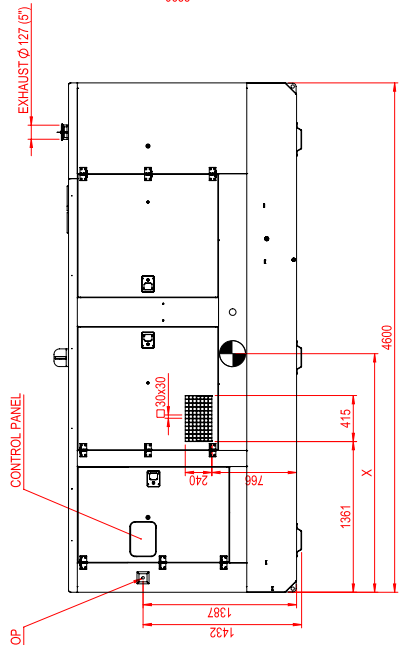
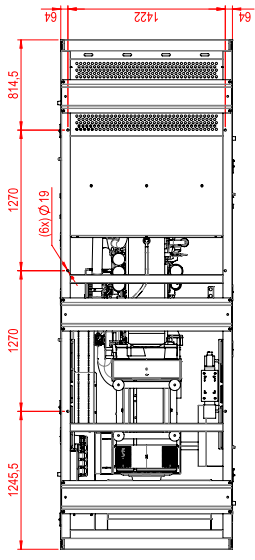
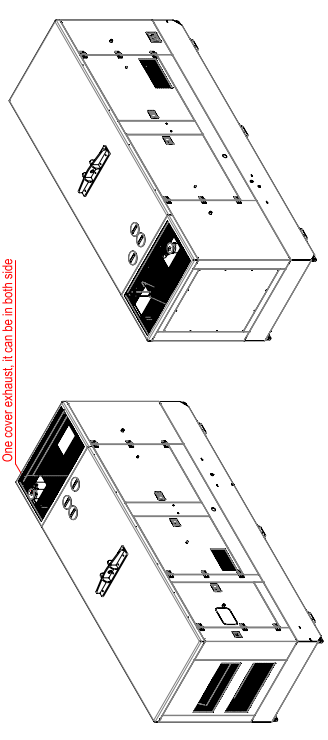

Measures in mm

Sommers reserves the right to change

GENSET	VOLTAGE	ENGINE	ALTERNATOR	CENTER OF GRAVITY	THEORETICAL WEIGHT (KG)
DGVSW 300 ST T2	240/120V 208/120V 600/347V	TAD 1341 GE	HC1 444E	2050	4450
DGVSW 300 ST T2	240/120V 208/120V 600/347V	TAD 1341 GE	HC1 444D	2060	4400
DGVSW 300 ST T3	240/120V 208/120V 600/347V	TAD 1351 GE	HC1 444E	2050	4450
DGVSW 300 ST T3	240/120V 208/120V 600/347V	TAD 1351 GE	HC1 444D	2060	4400
DGVSW 350 ST T2	240/120V 208/120V 600/347V	TAD 1343 GE	HC 444F	2045	4565
DGVSW 350 ST T2	240/120V 208/120V 600/347V	TAD 1343 GE	HC1 444E	2050	4450
DGVSW 350 ST T3	240/120V 208/120V 600/347V	TAD 1352 GE	HC1 444F	2045	4565
DGVSW 350 ST T3	240/120V 208/120V 600/347V	TAD 1352 GE	HC 444E	2078	4450
DGVSW 400 ST T2	240/120V 208/120V 600/347V	TAD 1344 GE	HC1 444F	2045	4565
DGVSW 400 ST T3	240/120V 208/120V 600/347V	TAD 1353 GE	HC1 444F	2045	4565

SOMMERS
Generator Systems

GENSET FKS

DGVSW 300-350-400 ST

23/06/2018

02/12/2020

SCALE: A2

01

1:30

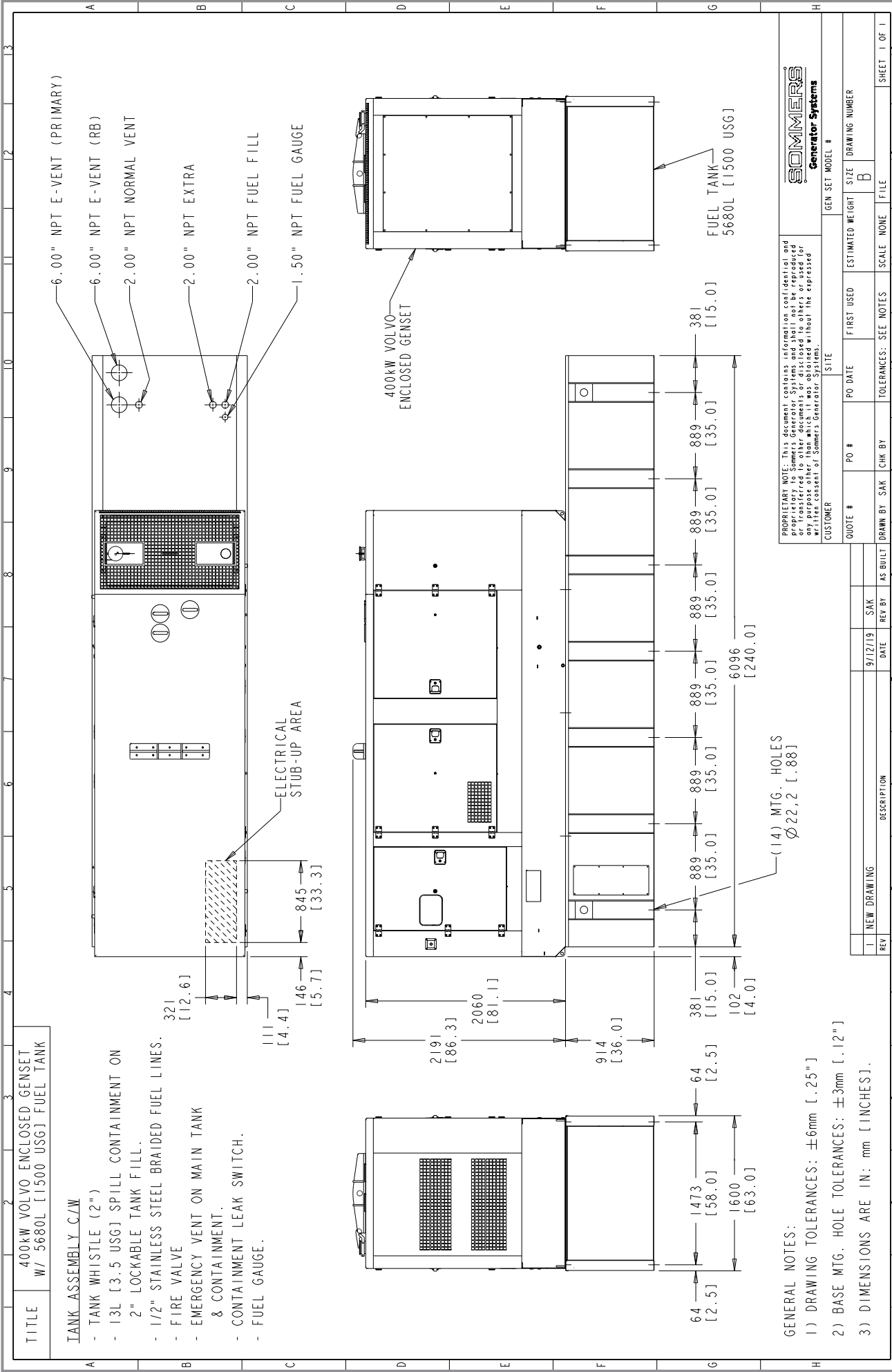

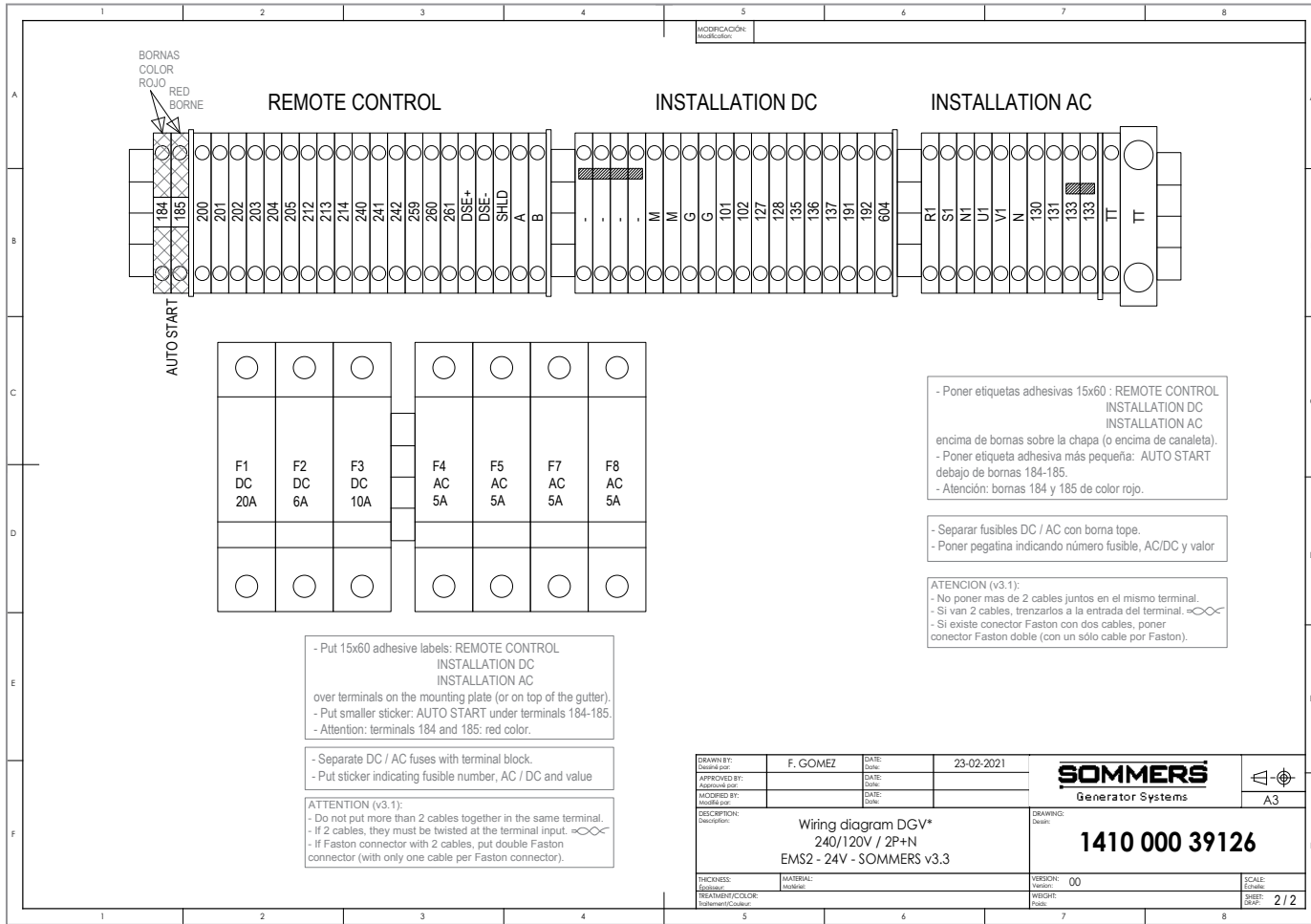
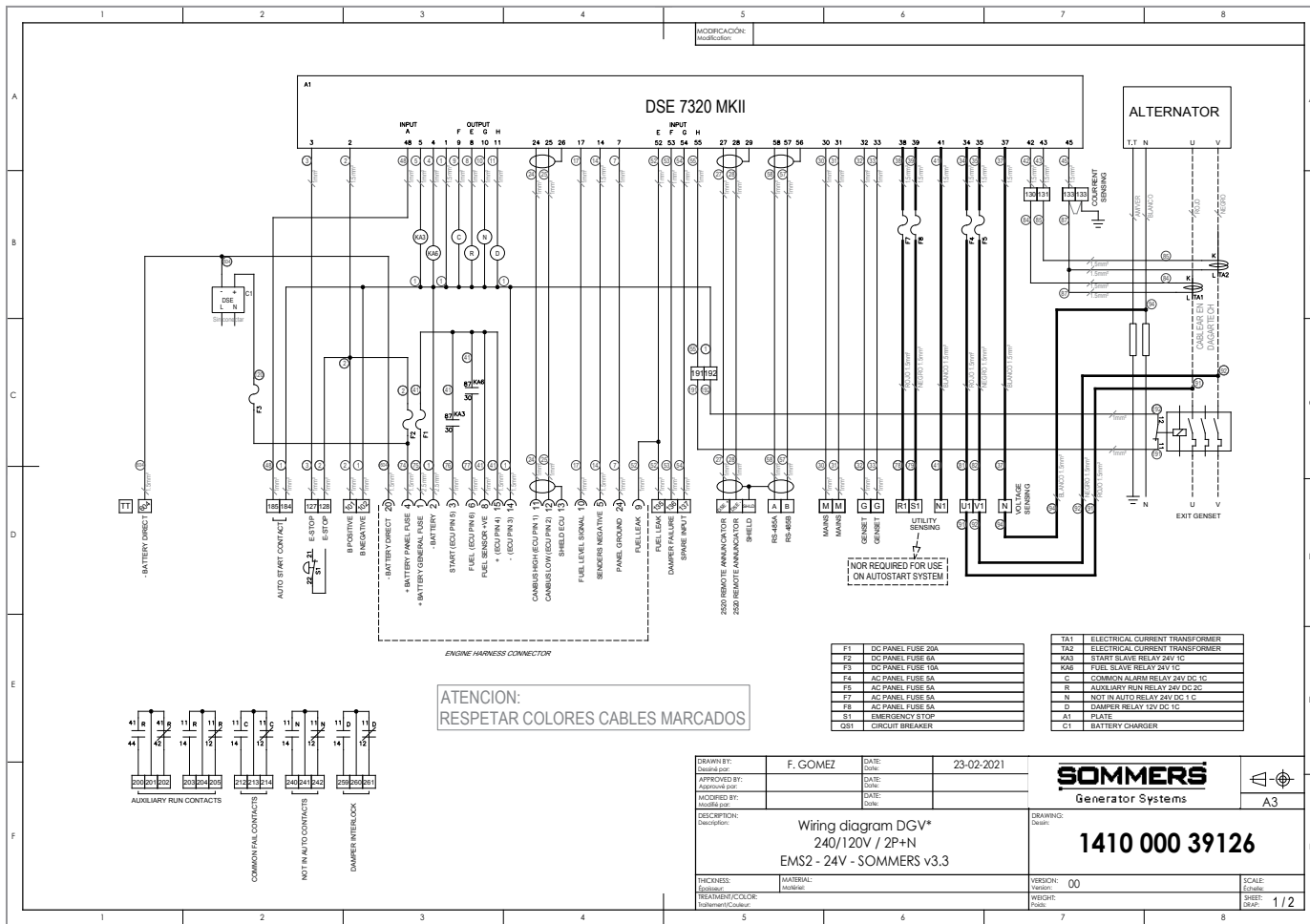

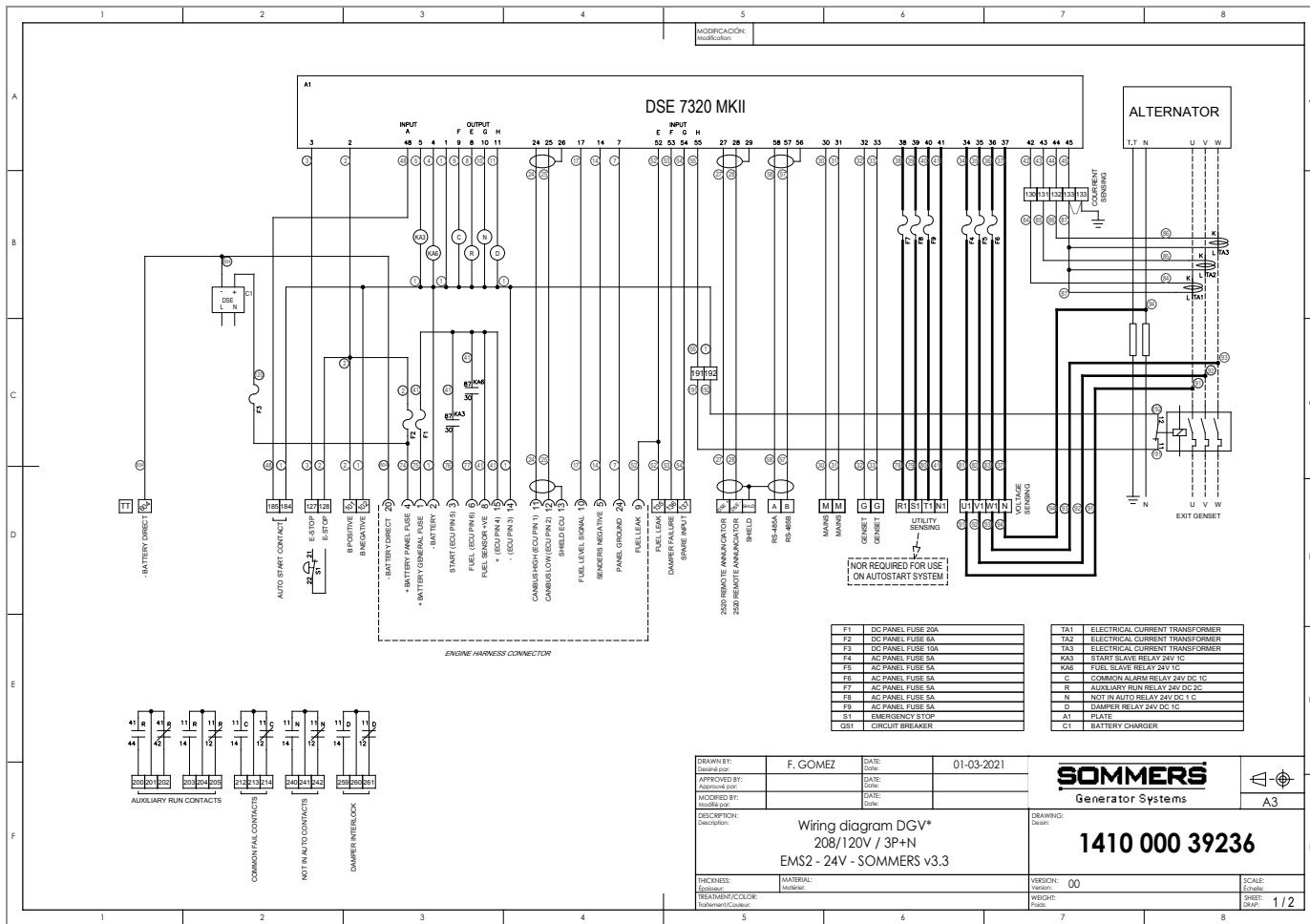

F1	DC PANEL FUSE 20A
F2	DC PANEL FUSE 6A
F3	DC PANEL FUSE 10A
F4	AC PANEL FUSE 5A
F5	AC PANEL FUSE 5A
F6	AC PANEL FUSE 5A
F7	AC PANEL FUSE 5A
F8	AC PANEL FUSE 5A
F9	AC PANEL FUSE 5A
S1	EMERGENCY STOP
CB1	CIRCUIT BREAKER

T1	ELECTRICAL CURRENT TRANSFORMER
T2	ELECTRICAL CURRENT TRANSFORMER
T3	ELECTRICAL CURRENT TRANSFORMER
KAS	START SLAVE RELAY 24V DC
KAF	FUEL SLAVE RELAY 24V DC
C	COMMON ALARM RELAY 24V DC 1C
R	AUXILIARY RELAY 24V DC 2C
N	NOT IN AUTO RELAY 24V DC 1 C
D	DAMPER RELAY 24V DC 1C
A1	PLATE
C1	BATTERY CHARGER

DRAWN BY:	F. GOMEZ	DATE:	01-03-2021
APPROVED BY:		DATE:	
MODIFIED BY:		DATE:	

SOMMERS
Generator Systems

A3

DESCRIPTION:
Wiring diagram DGV*
208/120V / 3P+N
EMS2 - 24V - SOMMERS v3.3

DRAWING:
Detail:
1410 000 39236

THICKNESS:	MATERIAL:	VERSION:	SCALE:
EQUIP:	INDICATE:	Variant:	1:1
TREATMENT/COLOR:		WEIGHT:	SHEET:
Preparation/Color:		Peso:	2 / 2

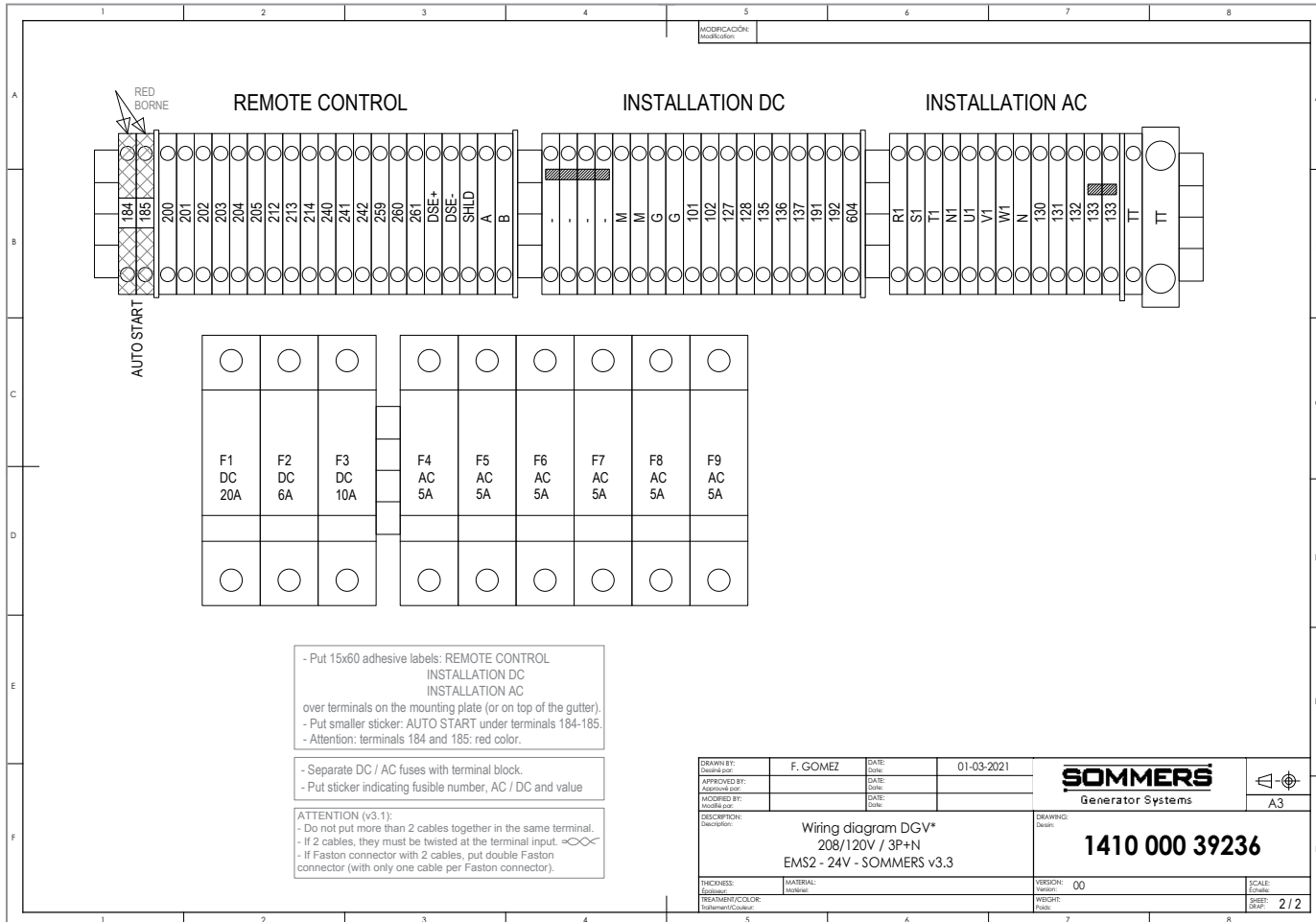

- Put 15x60 adhesive labels: REMOTE CONTROL
INSTALLATION DC
INSTALLATION AC
over terminals on the mounting plate (or on top of the gutter).
- Put smaller sticker: AUTO START under terminals 184-185.
- Attention: terminals 184 and 185: red color.

- Separate DC / AC fuses with terminal block.
- Put sticker indicating fusible number, AC / DC and value

ATTENTION (v3.1):
- Do not put more than 2 cables together in the same terminal.
- If 2 cables, they must be twisted at the terminal input. ∞∞
- If Faston connector with 2 cables, put double Faston connector (with only one cable per Faston connector).

DRAWN BY:	F. GOMEZ	DATE:	01-03-2021
APPROVED BY:		DATE:	
MODIFIED BY:		DATE:	

SOMMERS
Generator Systems

A3

DESCRIPTION:
Wiring diagram DGV*
208/120V / 3P+N
EMS2 - 24V - SOMMERS v3.3

DRAWING:
Detail:
1410 000 39236

THICKNESS:	MATERIAL:	VERSION:	SCALE:
EQUIP:	INDICATE:	Variant:	1:1
TREATMENT/COLOR:		WEIGHT:	SHEET:
Preparation/Color:		Peso:	2 / 2

