

REV.	ECN Number	Description	Drawn
1	CS17110042	RELEASE	XPG_2017. 11. 17
②	E18030017	ADD PART NUMBER	XPG_2018. 03. 20

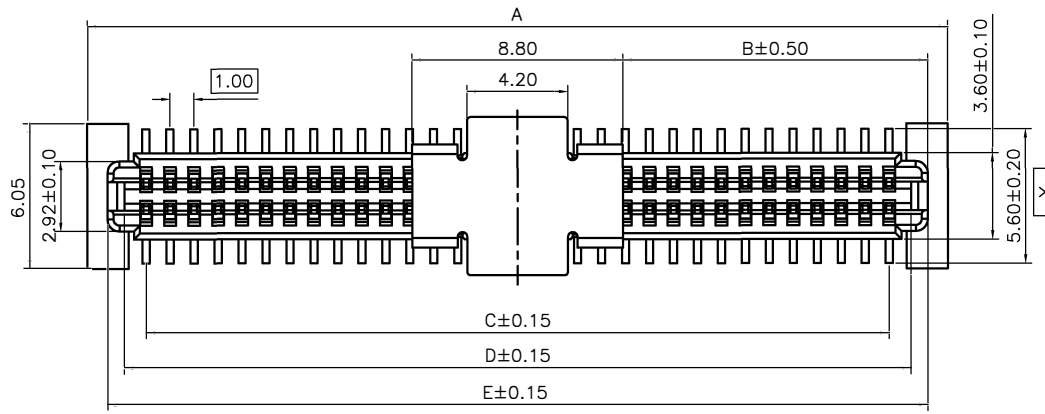

- NOTES: (UNLESS OTHERWISE SPECIFIED)
- DIMENSION SHALL BE INTERPRETED PER ANSI Y14.5M-1994.
 - MATERIAL:
HOUSING MATERIAL: HIGH TEMPERATURE PLASTICS, UL 94V-0.
CONTACT MATERIAL: COPPER ALLOY, T=0.20mm.
VACUUM COVER MATERIAL: STAINLESS STEEL, T=0.20mm.
 - ELECTRICAL SPECIFICATION:
CONTACT RESISTANCE: 30 m ohms MAX. INITIAL.
INSULATION RESISTANCE: 1000M ohms MIN.
OPERATION VOLTAGE: 100V AC/DC.
CURRENT RATING: 1.0A.
DIELECTRIC WITHSTANDING VOLTAGE: 250V AC.
 - MECHANICAL SPECIFICATION:
INSERTION FORCE: 120gf MAX. PER PIN.
WITHDRAWAL FORCE: 10gf MIN. PER PIN.
 - OPERATING TEMPERATURE: -55°C To +85°C.
 - PRODUCT NUMBER MATRIX:

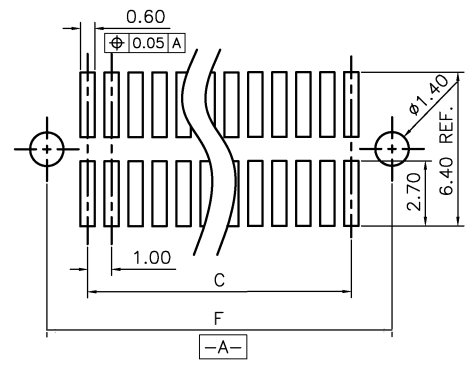
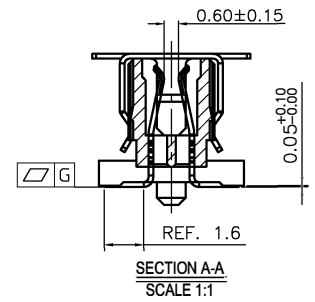
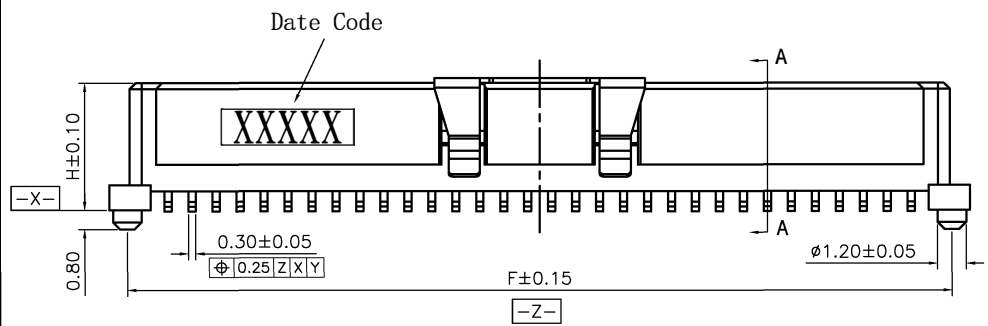

② B A 5 2-XX X T-X X -X H X

BTB Series code
1.00 Pitch
Receptacle
PIN No.
32:32PIN
40:40PIN
64:64PIN
84:84PIN
Height
A: H=10.30mm
B: H=7.30mm
C: H=5.30mm
Soldering Type
T:SMT
0:Without Post
1:With Post
Housing Color
Null:Nature
B:Black

Packing:
B:REEL+MPAD
Q:HOT SEALING
REEL+MPAD
H:Halogen free

Definition	Code
⊙ Matte Tin plated	A
⊙ Bright Tin plated	V
⊙ Gold plated over all	
flash B 1u" R 3u" C	
5u" D 10u" E 15u" F	
20u" G 25u" H 30u" J	
⊙ Duplex plated	
flash K 1u" S 3u" L	
5u" M 10u" N 15u" P	
20u" Q 25u" T 30u" U	
⊙ All plated is lead free.	

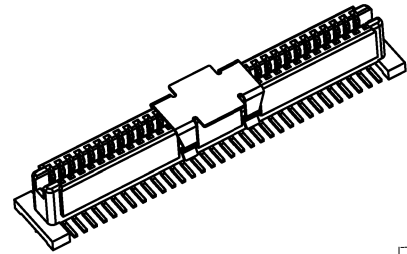

②

OLD AND NEW PART NO. COMPARISON	
OLD	NEW
RG101-648-D	BA52-64BT-1-UHB
AB52-64UB-H-002	BA52-84BT-1-UHB
RG102-648-D	BA52-64AT-1-UHB
AB52-64UB-H-001	BA52-64CT-1-UHB
RG103-648-S02-D	BA52-64CT-1-UHB

CKT	DIM A	DIM B	DIM C	DIM D	DIM E	DIM F	DIM G
32	19.90	4.71	15.00	16.82	18.22	18.40	
40	23.90	6.71	19.00	20.82	22.22	22.40	0.10
64	35.90	12.71	31.00	32.82	34.22	34.40	
84	45.90	17.71	41.00	42.82	44.22	44.40	0.12

	TOLERANCE UNLESS OTHERWISE SPECIFIED				SCALE 1:1	ORIGINAL DRAWN: Xu Peiguang	DATE 2018. 03. 20	DWG. NO. 600-0000-0339	TITLE BA52 CUSTOMER DRAWING	REV. 2
	X. X	±0.30	X. °	±3°	UNIT mm	CHECK: Xie Yong	DATE 2018. 03. 20	PARTS NO. (INTENDED USE) BA52-XXXT-XX-XHX	SHEET 1/1	
	X. XX	±0.20	X. X°	±2°	SIZE A4	APPROVE: Ady zhou	DATE 2018. 03. 20			
	X. XXX		X. XX°	±1°						