



Journal Issue

Robotic High Rises No.01: Design Research Studio 2012

Publication Date:

2012

Permanent Link:

<https://doi.org/10.3929/ethz-a-010709462> →

Rights / License:

[In Copyright - Non-Commercial Use Permitted](#) →

This page was generated automatically upon download from the [ETH Zurich Research Collection](#). For more information please consult the [Terms of use](#).



(FCL) FUTURE CITIES LABORATORY

未来城市实验室



ETH zürich

DARCH

(SEC) SINGAPORE-ETH CENTRE 新加坡-ETH 研究中心

(FCL) FUTURE CITIES LABORATORY 未来城市实验室

CREATE

Robotic High Rises No.01

FCL Magazine Special Issue

FCL MAGAZINE SPECIAL ISSUE Robotic High Rises No.01

Design of Robotic Fabricated High Rises | Research Module of Architecture and Digital Fabrication | Gramazio & Kohler | Future Cities Laboratory

Design Research Studio 2012

Foreword

The work presented in this special issue of the FCL Magazine focuses on work emerging from the design research studios conducted in Singapore by the architecture and digital fabrication team, lead by Profs Fabio Gramazio and Matthias Kohler. The design research studio is a hybrid research format that deals as much with the identifying, shaping and setting of research problems, as much as it does solving them. It is a form of research that shuttles between empirical investigation and creative proposition-making. The design research studio is also an effective and meaningful way of integrating masters students, PhD candidates and postdoctoral researchers into a collective inquiry.

The digital fabrication team have innovated around the design research studio format in the context of Singapore's famous high-rise and high-density built fabric. The format has enabled them to develop collaborative research and teaching platforms with colleagues and students from the National University of Singapore, and ETH Zürich. The distinctive features of the design research studio – interacting with more conventional modes of scientific inquiry – allows researchers to test, refine and develop compelling visions, and credible technologies and processes that sustainable future cities will require.

Stephen Cairns

Editorial

High-rises represent the most common typology for residential projects in South-East Asia, where they dominate large parts of the urban landscape. An unbroken demand for housing space coupled with decreasing availability of usable land resources continues to push the limits of vertical growth. Construction technologies are still rooted in a quite anachronistic industrial paradigm. They are mainly driven by efficiency and economic factors and thus widely lead to the creation of mono-functional and highly repetitive urban environments. Hence the question, how might contemporary computer-aided architectural design contribute to the differentiation of these environments? And how might the investigation of robotic construction support this agenda in the context of large buildings?

The Design Research Studio 2012 was conducted by the Module of Architecture and Digital Fabrication at the Future Cities Laboratory in Singapore. From the beginning, participating students were encouraged to question conventional approaches to architectural design. Instead of sketching and drawing, they began with a programming process that directly engages the robotic construction of a high-rise tower. Tool-based tutorials familiarised students with robotic technologies and appropriate software environments. Understanding robotic fabrication and digitally based design processes before a first tower was envisioned allowed them to explore new constructive and spatial concepts. Assembly and organisational strategies transformed quickly from simple pick-and-place

logics to more refined fabrication processes. Whereas one project demonstrated the capability of handling an exceptionally large number of elements that could not be controlled by manual or conventional construction technologies, another project looked into the fluent assembly of parts with highly differentiated geometries. A third project explored the potential of assembling a generic set of sheet components that are deformed during the robotic fabrication process to define individual spatial configurations.

Based on these projects, students first looked into hypothetical concepts of 1:1 robotic construction and their correlation with new types of building components; as a second step, they incorporated these concepts into refined and well-articulated architecture projects. Surpassing the abstract and merely structural models of earlier and experimental stages, the final projects integrated enclosure systems that correlated with the primary building systems. Over the course of the year, the adaptation of the digital design environment, along with the intensive examination of toolsets as the interface between robotic fabrication and material assembly, played equally important roles. These processes were co-advised by three PhD researchers focusing on the topics of computational design, robotic fabrication and constructive systems – their research in turn was greatly enhanced by the studio (see FCL Magazine Special Issue 'Robotic High Rises No.03').

Michael Budig and Raffael Petrovic

CONTENT

Guest critics and lecturers 2012:

Thomas Bock
Philippe Block
Hans Brouwer
Stephen Cairns
Kees Christiaanse
Stylianos Dritsas
Christophe Girod
Dirk Hebel
Sawako Kaijima
Erik L'Heureux
Lorenz Lachauer
Daniel Meyer
Shinya Okuda
Francois Roche
Florian Schätz
Milica Topalovic

Acknowledgements:

The studio in 2012 was conducted with support of the Faculty of Architecture (DARCH) at the Swiss Federal Institute of Technology in Zürich (ETH).

2	FOREWORD <i>Stephen Cairns</i>
3	EDITORIAL <i>Michael Budig, Raffael Petrovic</i>
14	STUDIO AGENDA: ROBOTIC HIGH RISES <i>Michael Budig, Willi Lauer, Raffael Petrovic, Jason Lim</i>
26	PROJECT SITES
28	PROJECT 1: BENT STRATIFICATIONS <i>Silvius Kramer, Michael Stuenzi</i>
56	PROJECT 2: NESTED VOIDS <i>Pascal Genhart, Tobias Wullschleger</i>
84	PROJECT 3: UNDULATING TERRACES <i>Sebastian Ernst, Silvan Strobbach, Sven Rickhoff</i>
110	PROJECT 4: SHIFTING VOLUMES <i>Alvaro Valcarce</i>
120	ADDENDUM
128	COLOPHON



Future Cities Laboratory / Research Module of Architecture and Digital Fabrication

Robotic and automated productions have taken over large parts of many industrial sectors. Although highly ambitious and sophisticated, most attempts at using robotic processes in architecture remain exceptions, prototypes or even failures at a larger scale, because the general approach is either to automate existing manual processes or to automate the complete construction process. However, the potential of robotic fabrication is not fully exploited if used for the execution of purely repetitive mass fabrication processes. Robots can be controlled individually and thus offer the potential for variety and differentiated assembly - even at large scale. The challenges of diverse construction systems and changing demands for each

project need to be taken into account, without limiting the range of design. Existing methods and processes have yet to be negotiated in this context. It is time to think about customised robotic processes, products and planning methods for architecture at large scale. At the SEC Future Cities Laboratory, our Chair of Architecture and Digital Fabrication has built up a laboratory to research the potential of robotic processes in architecture and to develop concrete scenarios for their large-scale application to the design and construction of novel high-rise typologies.

Fabio Gramazio and Matthias Kohler







Robotic High Rises

Integrating robotic fabrication in a design research studio

Michael Budig, Willi Viktor Lauer,
Raffael Petrovic, Jason Lim

The methodology in the design research studio aimed for the reconsideration of the traditional architectural model by directly linking the digital design process with physical manufacturing and tools. As such, it established a strong correlation between computational design, material systems and robotic fabrication strategies. Since high-rises are strongly rooted in the industrialisation of building, with repetitive elements stacked along the vertical axis, they represent an interesting architectural typology to be challenged by this new design and fabrication paradigm. Some of the main strategies of both studio years are revisited and compared on the following pages.

High-rises dominate large parts of the urban landscapes in fast growing regions throughout Asia. In cities like Singapore a majority of the population lives in residential high-rises.¹ The construction of this typology is strongly rooted in a Modernist industrial paradigm – it is mainly driven by efficiency and economic criteria, with repetitive elements being stacked along a vertical axis. The questions inevitably arise, how contemporary computer-aided architectural design with the integration of robotic fabrication could contribute to a differentiated articulation and leverage more variety in the formal expression and functional capabilities of this widespread typology. The design methodology itself comes into the focal point of investigations, which is pursued in the context of a design research studio. The experimental design research studio investigates potential impacts of these technologies on the design and construction of novel high-rise typologies through the robotic fabrication of 1:50 scale models of mixed-use residential high-rises. It is run in close interaction with the PhD researchers of the Module of Architecture and Digital Fabrication, which serves as an experimental test bed for both digital design and fabrication research. Here, PhD research on constructive systems, on computational design processes and the development of software environments to control robots play a crucial role in the studio. The studio in return offers important test cases.

Within the design studio teams of two to four students develop their architectural concepts based on the integration of computational design strategies and bespoke robotic fabrication processes. The physical and the digital models are in constant negotiation with one another. Therefore constraints of the actually built model, e.g. in terms of material properties or manageable element dimensions, directly influence the computational design setup in a continuous feedback loop. The model scale of 1:50 requires a careful selection and abstraction of investigated aspects, but also demands a rigorous consideration of its tectonic logic. Up to four metre high models create their own constructive reality (Fig. 01). They oblige students to tackle problems of structural stability and the logical sequence of the construction process from the very beginning on. In what follows, we will describe a) the unique robotic system, b) the embedded mechanical tools such as the development of customised end-effectors, and c) the design research through architectural models by illustrating the conceived physical processes for their construction.



Fig. 01 Studio tower models that were built in several iterations

Robotic system

Students and researchers share three customised robotic units. Each one consists of a lightweight Universal Robots UR5 robot arm with six degrees of freedom that is mounted to an automatically driven Guedel axis configuration (Fig. 02).² This robotic system enlarges the working space of the robot arm from a range of 85 cm to a construction envelope of 4 m height, 1.7 m width and 2.7 m depth; due to its small operating diameter the robot arm can still reach very intricate locations. This allows for the digitally controlled assembly of complex physical models at the scale of 1:50. In addition, a high degree of modularity accommodates quick modifications of the robotic system, e.g. their height and thus the operating space can be adjusted without the need of additional special tools. Four adjustable base points enable the robotic tower to be levelled and transfer its 1.2 tons to the floor. Overall, this unique robotic setup offers flexible and extendable configurations, thus allowing for a rapid transition of digital designs from computation-only models to real-world robotic construction.

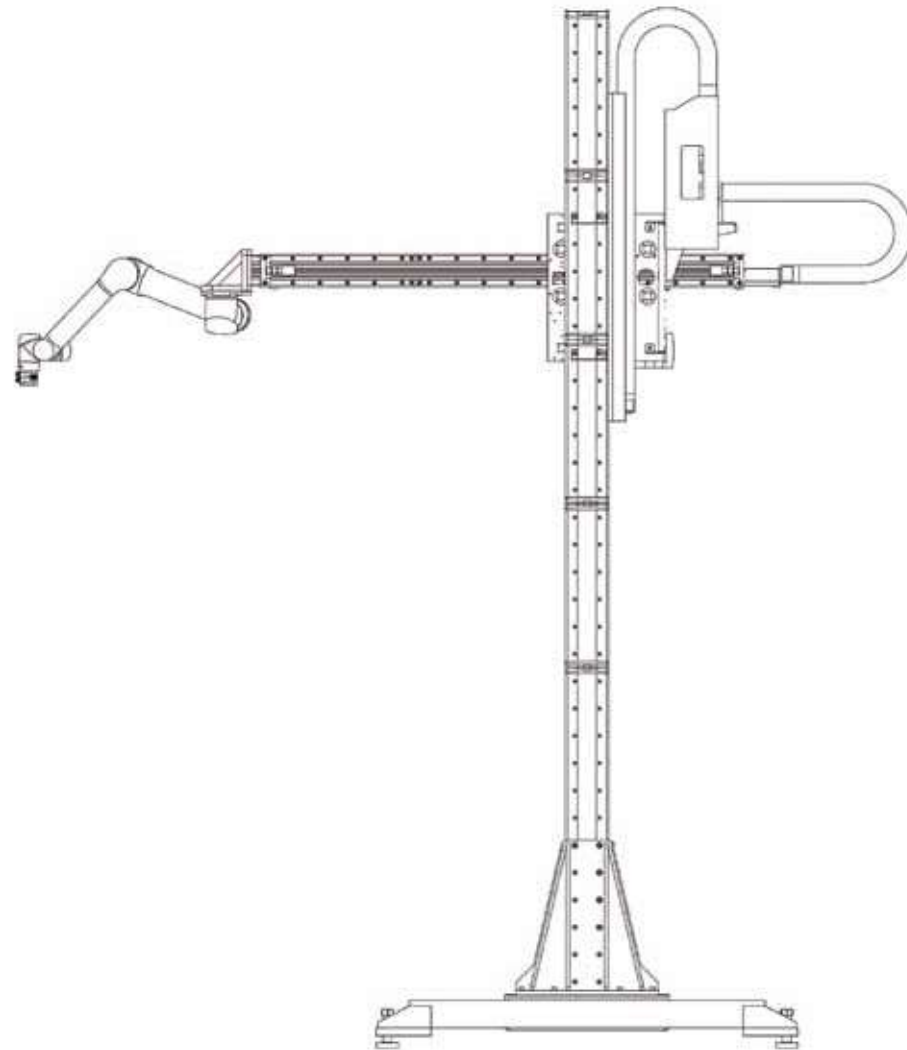
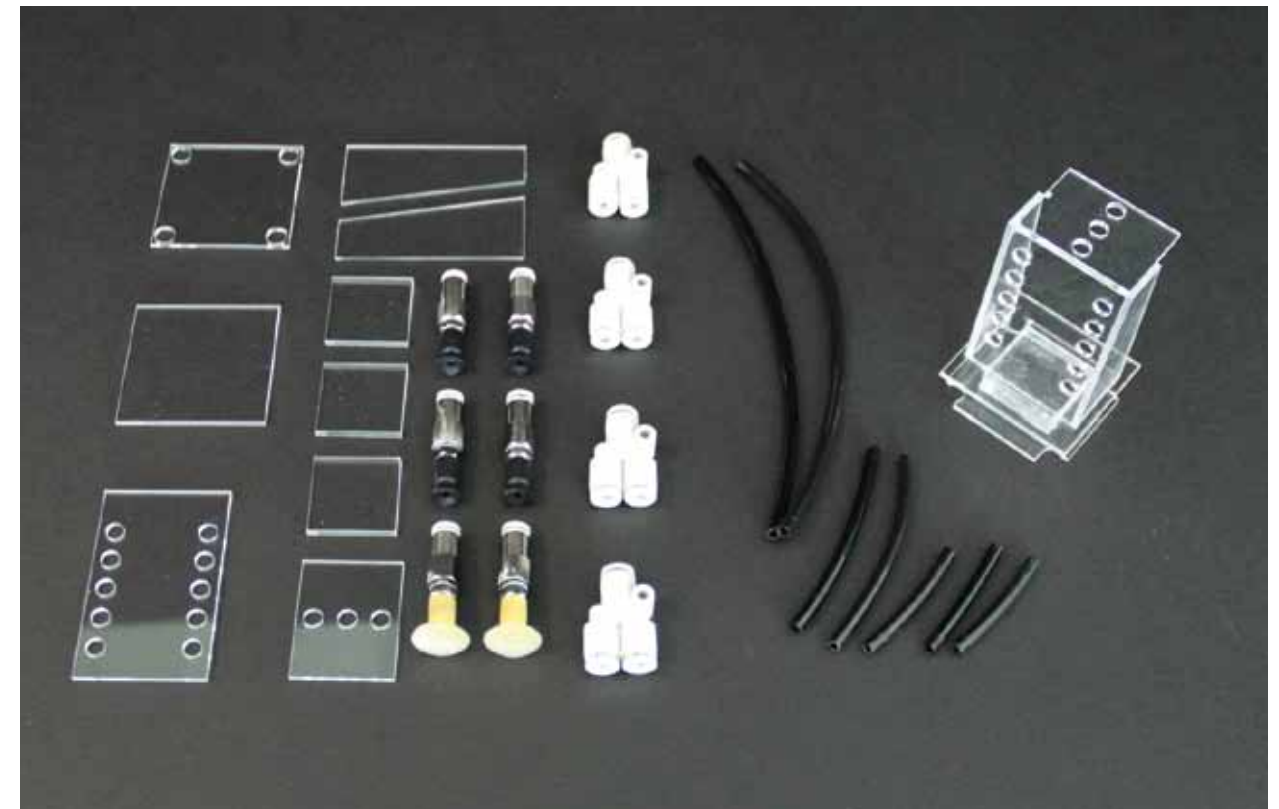

Fig. 02 Elevation of one of the robotic fabrication units, where a Universal Robot UR5 robotic arm is mounted to a Guedel axis system in order to increase the building envelope

Physical tools and end-effectors

For the development of a robotic fabrication process in the design research studio the robotic end-effectors become the most crucial physical components. Available mechanical grippers are mostly not flexible enough to grasp pieces of various sizes and geometries, and can hardly be adapted to different assembly concepts. To overcome these limitations a modular gripper system was developed to enable multiple options of mechanical and vacuum suction gripping. Students can design and produce these grippers easily and develop their own specific configurations for the model building process (Fig. 03). While the initial focus was put on the gripper geometries for controlled picking and placing routines, more elaborated concepts were eventually designed with higher functional integration, such as, for example, sensor equipment and high-resolution control valves for optimised vacuum suction grippers.

Fig. 03 Picture of a basic modular gripper setup that can be altered and amended by students



Since the previously developed grippers with suction cups restricted the building components' geometries, a second generation of vacuum grippers emerged from the idea to perforate a gripping surface with hundreds of small apertures. These grippers are built out of three layers of thin Plexiglas. The first layer is the perforated surface, with the air-feeding layer below and the third layer covering the feeding cavity from the backside. With this configuration grippers could easily be produced by a laser cutter and customised to the elements' intricate geometries. Due to the thin build-up of the grippers of only 5 mm, they were particularly well suited for dense assemblies at 1:50 model scale (Fig. 04).

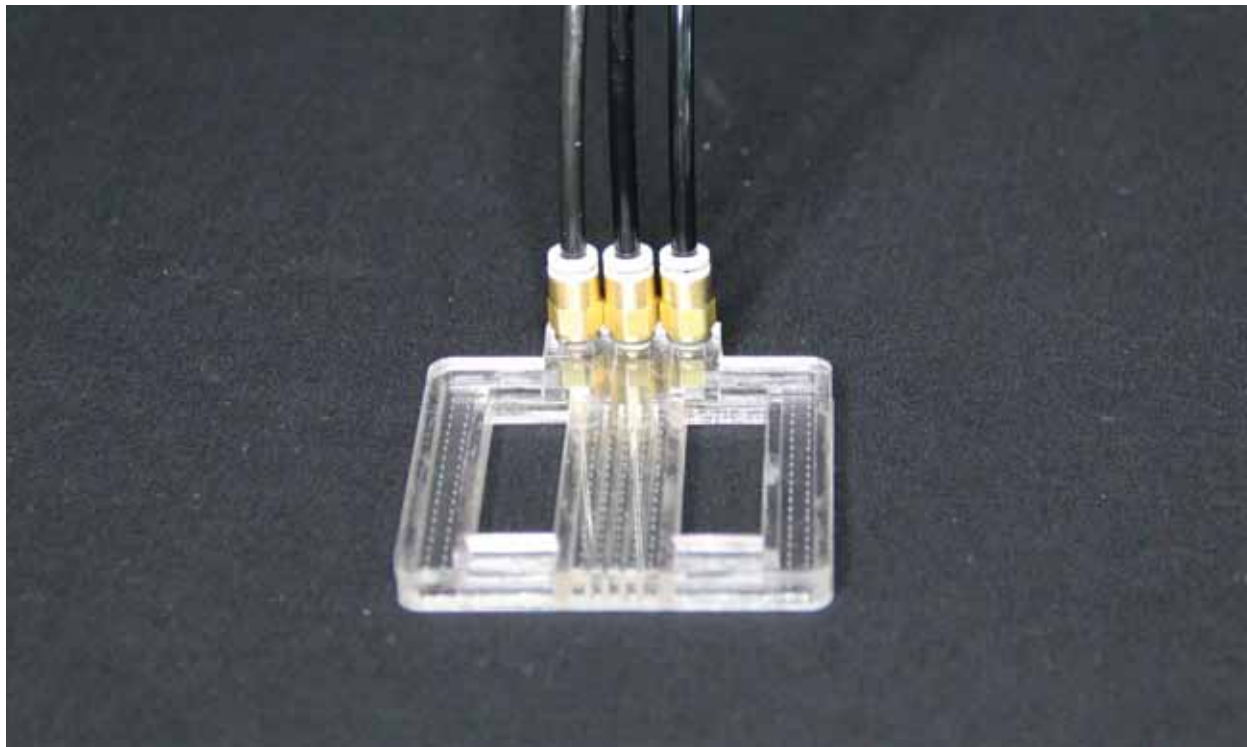

Fig. 04 The thin buildup of the gripper makes it suitable for dense assembly configurations

As the lightweight robotic arms employed in the design research studio are equipped with built-in safety systems, they do not need to be sheltered in a safety environment like their industrial counterparts. This feature opens the possibility for immediate human-robot interaction, which, in turn, allows a direct, intuitive and continuous process of refinement and adaptation of the end-effectors by the students. As such, the operating paradigm of the robotic towers is to combine the highest possible level of accessibility, human intervention and safety in the laboratory environment.

Software Tools

In a similar vein to the customisable hardware components, a custom robot programming library called YOUR and a corresponding toolkit of Grasshopper³ components that are open to end-user modification were developed. These software tools aim at making robot control accessible to students without prior specific knowledge or programming skills. Either students use the toolkit from the Grasshopper visual programming environment or they start from the script editor in the McNeel Rhinoceros 3D Modeler; the former is geared towards those without any programming experience while the latter suits experienced programmers. In either case, students are able to control the robot directly from their computational design environment. By directly assembling components from the Grasshopper toolkit, students are able to set up and control their custom robotic fabrication sequences. This visual programming approach facilitates students in quickly prototyping processes, as they only need to learn how a few essential components work and can then connect them in different ways. Since the text based code defining these components is accessible, students become able to modify them once they acquire more experience

in programming and knowledge in robotics. This allows them to introduce more complex assembly logics and more intricate robot motion patterns for material manipulation.

Fabrication techniques

The first aim of the design research studio was to build models as high as possible to gauge the limits of the robotic facilities. Initial towers were stacked configurations and fabricated with simple pick and place fabrication processes, for which the students developed different vacuum gripper systems to glue and place cardboard elements. The design of these grippers had to consider essential fabrication parameters, such as material thicknesses, drying times, and height deviations caused by the applied layers of glue. In the beginning the negotiation between the absolute precision of a computer model and the approximation of the material reality mediated by the robot had been the major challenge. Later phases led to the emergence of fabrication strategies, which utilised the robots inherent manufacturing potential as unique drivers for the architectural design.

Picking and placing

One early concept deployed in the design research studio investigates how models can be built through the robotic aggregation of a very large number of small identical components resembling a “constructive 3D printing” process. In order to achieve this goal in an efficient manner, a custom end-effector incorporating a feeder system as well as an automated gluing device have been developed. Using spray glue, this system can hold several hundred pieces at a time and consequently speeds up the construction process by minimising the distance the robotic arm has to travel for placing each individual piece. One of the towers produced with this process consists of more than 15.000 cardboard pieces of two different geometries. Here the challenge is to realise structural systems that are able to cantilever outwards from a vertical core system (Fig. 05).

Fig. 05 Customised gripper system that glues and places small building components in one step

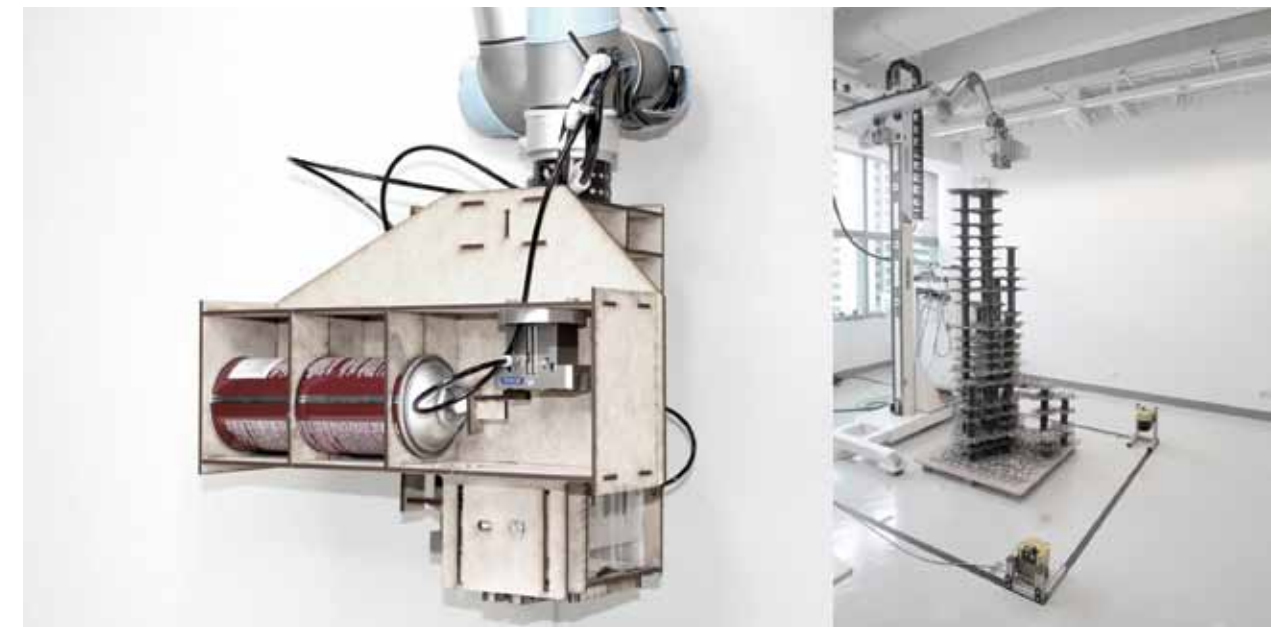

Fig. 06 Picture of a combined feeder and end-effector system; the feeder allows the students to directly place prepared laser cut sheets for the assembly process



Another fabrication concept focuses on the seamless integration of the laser cutter, allowing students to produce and assemble elements with different sizes and geometries within an efficient workflow. Since the picking point varies for each piece, a corresponding feeder system and visual programming setup are developed. The cardboard containing the prefabricated elements gets constrained to fit into the robot's workspace. The individual sheets are then placed directly on the feeder that contains a gluing station. Algorithms are used to generate the layout of the elements on the laser-cut cardboard sheets, and to coordinate the picking, gluing and placing movements of the robot (Fig. 06).

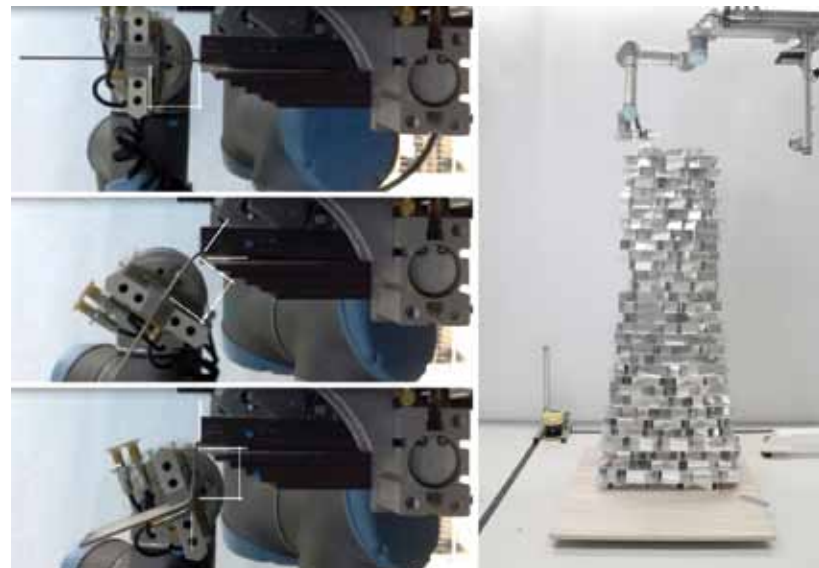

Fig. 07 Picture of cardboard folding process and tower model made of more precise aluminum sheets

Material deformation processes

Beyond picking and placing strategies the integration of material deformation processes further explores the potential of the robot in its unique capacity to produce bespoke parts departing from identical, mass-produced elements. In a first step, the implementation of a folding process allows to enhance the picking and placing of cardboard pieces by enabling the production of large numbers of geometrically differentiated elements. The next iteration of this process uses thin aluminium sheets, which are bent to more precisely defined angles. The process makes use of two mechanical grippers, one holding the piece in place while the other, mounted directly to the robotic arm, grips the sheet and rotates it around the stationary one – thus controlling the geometry of the folding process (Fig. 07). As a result, by robotically bending each piece in two opposite directions, each sheet becomes a structurally stable wall element. The subsequent picking and placing process of the folded wall elements in layers is controlled by an algorithmic process, which ensures the continuous vertical load transfer by specifically defining the horizontal intersections between the different layers. This proves to be a powerful strategy to exploit the robot's potential of complex spatial movements to integrally inform the applied material's geometry as well as its assembly. In contrast to simple picking and placing, the robot plays an active role in the form-giving process of the individual component.

Three additional projects enhance the geometric freedom of the form-giving capacity of the robotic arm by integrating a heat gun into the process. One concept involves bending acrylic stripes at multiple points to create a tower's primary structural system. After the thermal deformation, the pieces are cooled down with pressurised air in order to avoid retraction and increase assembly speed (Fig. 08). A similar process is used in another project for twisting acrylic sheets and producing a geometrically complex facade louver system. To integrate the previously developed picking and placing process with the material deformation, a combined mechanical and vacuum suction gripper was developed (Fig. 09).

Fig. 08 The acrylic stripes are fixed in a linear rail and pulled forward to their designated bending position. The material gets heated up for 10 seconds and allows the robotic arm to bend the material to any angle between 0° and approximately 160°. After the deformation the material gets cooled down with air pressure

Fig. 09 Combined gripper for picking identical building elements and deforming them with an integrated heat gun



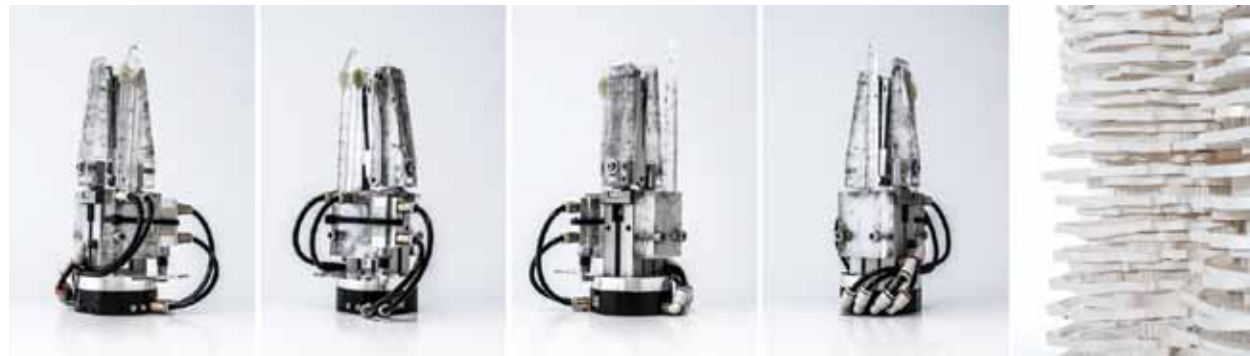

Fig. 10 Tower made out of paper stripes and stapling process, which uses paper's intrinsic properties in the material deformation process

An entirely different approach to robotic material deformation is showcased by a project using generic paper strips as main building material. By connecting two overlaid paper strips at one point and then sliding their relative position before connecting them again, it is possible to produce geometrically highly differentiated building components with undulating geometries (Fig. 10). This process includes the development of a gripper that can pinch two stripes of paper and then staples them together to fixate their final positions. The resulting wall elements are self-stabilising and can be layer-wise assembled into an expressive high-rise structure. As the produced component geometries are a direct result of the material's intrinsic capacities, the process is parameterised in order to seamlessly connect the digital to the physical model, and to enable adjustments in multiple feedback loops.



Fig. 11 The tower is made out of paper elements that are manually cut and then robotically folded, glued and placed onto the model

Integration in architectural concepts

The second studio year builds upon previously designed fabrication concepts and reevaluates these processes in correlation with algorithmic design strategies. The initial setup allows students to start building physical models from the beginning on – thus shifting the focus of the investigation away from digital fabrication experiments towards the development of specific computational design engines, which maximise the potentials of the previously developed robotic fabrication methods and techniques.

Connecting algorithmic design and robotic fabrication

By robotically building physical models and analysing aspects such as structural behaviour, material performance and overall architectural qualities, the students were able to materially inform and specifically adapt their computational design engines in iterative steps, whereby the empirically gained results were further used to rethink and to advance the fabrication process itself (Fig. 11). As an example, some processes demand for the integration of optical sensors that would enhance fabrication precision and allow the implementation of particularly complex manipulation sequences. Sensor technology also enables the integration of human-robot cooperation in a seamless manner as the process could autonomously stop when a manual intervention would become inevitable (Fig. 12). Other projects question the fabrication suitability of a given material system and design a completely new robotic fabrication method that optimises the robot capabilities to become the key driver to their design (Fig. 13).

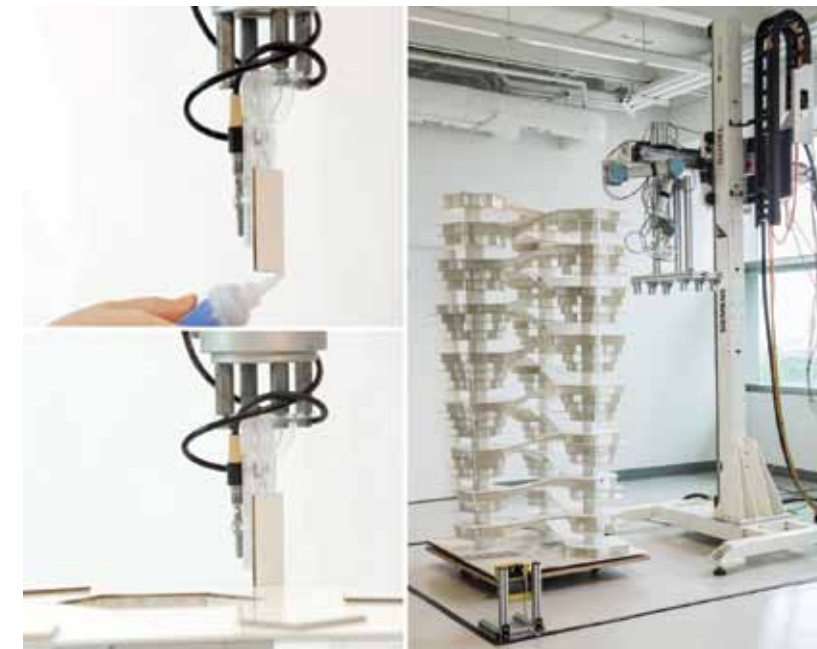

Fig. 12 With sensor integration into the gripper system the fabrication process becomes more reliable and faster; the pieces are 'handed' over to the robot, that assembles them onto the model

Fig. 13 The robot picks extruded Styrofoam cubes and moves them through the hotwire along a computed path, thus utilising the robot's potential for performing spatially programmed fabrication tasks



Outlook

The design research studio offers a unique experimental test bed, giving the physical architectural model a new meaning and revaluing its importance in the combination with digital design tools. The empirical developments of the designs in correlation with the physical artefact obliges students to deeply and creatively engage with robotic fabrication logics, which become, in turn, a crucial part of the design. The iterations of high-rise models involve continuous feedbacks between physical result and digital design concept. Beyond that, the models reach a complexity (both formal and structural), which could not be manually achieved. The robot thus catalyses new design explorations and avoids conventionally split design and fabrication sequencing, where the final design data gets handed over to a completely separated fabrication process.

Within this scope of directly linking the digital design process with robotic manufacturing as well as with its computational and physical tooling, twenty-seven 1:50 models were produced in total in the studios 2012 and 2013. Here, the consistent interaction with the robotic process leads to a direct and sensual understanding of the tectonic qualities in the model. This exposure to the process of making also requires a profound understanding of the tools and their effects on material and geometric shapes. The role of the architect is challenged here, where design opportunities become sustained in physical space through the adaption and even invention of novel tools and techniques. This design research methodology proves to be a valuable experiment on the way towards a deeper conceptual integration of robotic fabrication paradigms in the design process of novel large-scale architectural typologies.

References

- Gramazio, F., Kohler, M. and D'Andrea, R. (2013) *Flight assembled architecture*. Orléans: HYX.
- Budig, M., Lim, J. and Petrovic, R. (2014) 'Integrating Robotic Fabrication in the Design Process', *Architectural Design*, No 229: 22-41.
- Cousineau, L. and Miura, N. (1998) *Construction Robots: The Search for New Building Technology in Japan*. Reston: ASCE Publications.
- Gramazio, F. and Kohler, M. (2008) *Digital Materiality in Architecture*. Baden: Lars Müller Publishers.
- Gramazio, F. and Kohler, M. (eds) (2014) *Made By Robots: Challenging Architecture at a Larger Scale*, *Architectural Design* No 229, London: Wiley and Sons.
- Hack, N., Lauer, W., Langenberg, S., Gramazio, F. and Kohler, M. (2013) 'Overcoming Repetition: Robotic fabrication processes at large scale', *International Journal of Architectural Computing IJAC*, 3 (11): p. 286-299.
- Nerdinger, W., Barthel, R., Junge, R., Kripper, R., and Petzold, F. (2010) *Wendepunkte Im Bauen: Von der seriellen zur digitalen Architektur*. Dresden: Detail.
- Lim, J., Gramazio F. and Kohler, M. (2013) 'A Software Environment for Designing through Robotic Fabrication', *Proceedings, CAADRIA Conference*. Singapore: National University of Singapore. p. 45-54.
- Menges, A. and Ahlquist, S. (2011) *Computational Design Thinkin*. London: Wiley.
- Monkman, G., Hesse, S., Steinmann, R. and Schunk, H. (2007) *Robot Grippers*. Darmstadt: Wiley-VCH.
- Reiser, J. and Umemoto, N. (2006) *Atlas of novel tectonics*. New York: Princeton Architectural Press.
- Sheil, B. (2005) 'Transgression from Drawing to Making', *Architectural Research Quarterly* 9 (1). Cambridge: University Press. p. 20-32.
- Willmann, J., Gramazio, F. and Kohler, M. (2014) *The Robotic Touch - How Robots Change Architecture*. Zürich: Park Books.
- Willman, J., Gramazio, F., Kohler, M. and Langenberg, S. (2012) 'Digital by Material' in Brell-Cokcan S, Braumann, J (eds), *ROB|ARCH 2012: Robotic Fabrication in Architecture, Art, and Design*. Vienna: Springer. p. 12-27.

Endnotes

- ¹ In Singapore more than 80% of the population lives in high-rise and high-density flats built by the Housing Development Board (HDB).
- ² The Universal Robots UR5 robot arms are integrated in Guedel 2-axes linear modules type ZP-3.
- ³ Grasshopper is a visual programming plugin for the widely used McNeel Rhinoceros 3D modeling software.

Credits

This text is an excerpt of a paper that was originally published in Mc Gee, W. and Ponce de Leon, M. (eds) *Robotic Fabrication in Architecture, Art and Design 2014*. New York: Springer. p. 111-130.

Project Sites



JURONG

REDHILL

PEARL BANK

Bent Stratifications

Jurong Lakeside District

Students: Silvius Kramer,
Michael Stuenzi

The multifunctional towers are conceived as stacking of identical elements, which are processed by the robot into construction components with unique geometries. Here, acrylic strips with varying lengths are placed on a linear track system to advance them into the right position, where they are heated up by a heat gun and then, ultimately, deformed by the robotic arm. After having been cooled down by cold pressurised air, the bent acrylic strips are sequentially placed by the robotic arm at their final position onto the already built structure. Through this digitally controlled robotic prefabrication and assembly process, each acrylic strip can be individually rotated and positioned, preserving overall structural integrity, such as, for example, transferring the dead loads at defined intersection points. Moreover, by varying the number of elements forming a wall segment, this approach allows to specifically differentiate the floor-to-ceiling heights, thus creating a multitude of split-levels to accommodate a range of mixed-used architectural programmes.



Computational Design

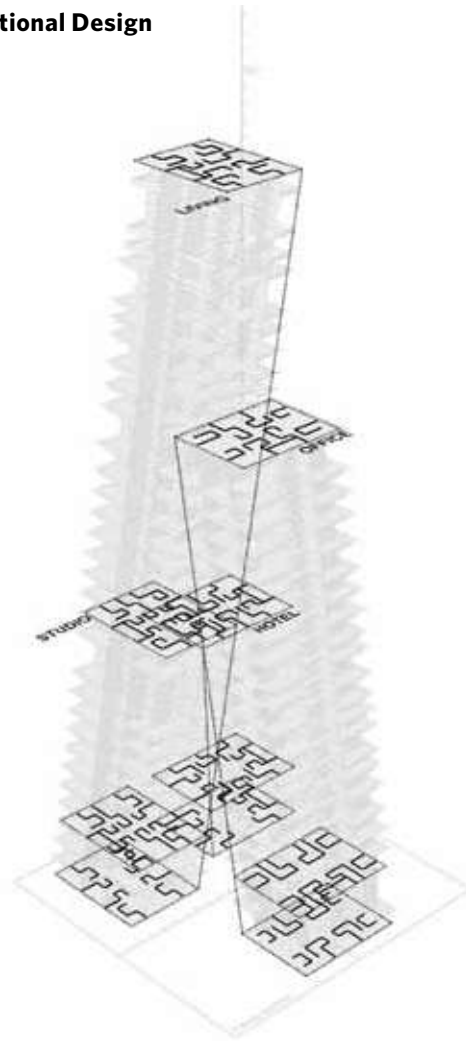

1: Generation of floor plans

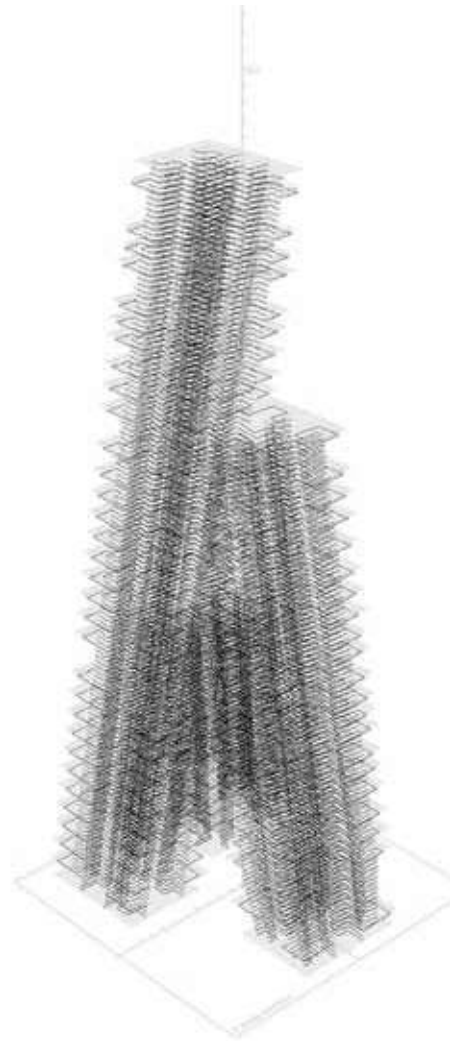

2: Generation of walls and beams

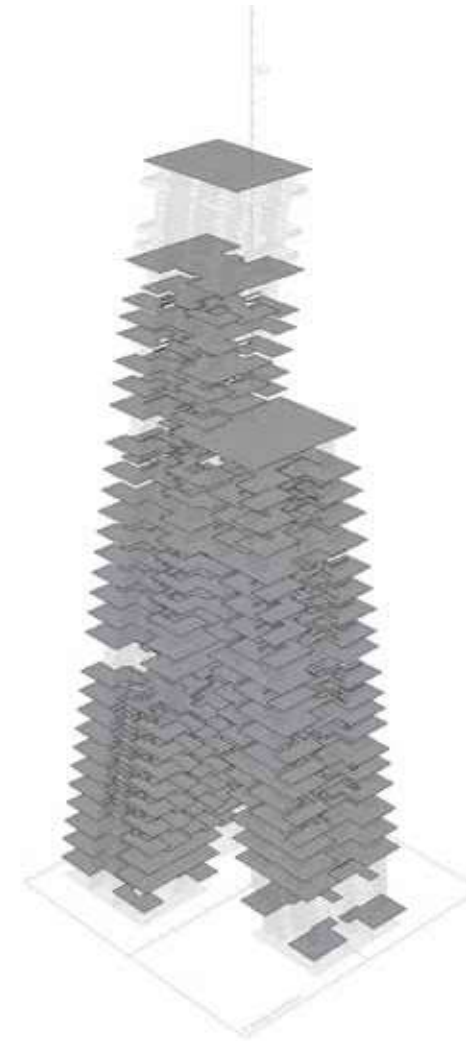

3: Generation of floor plates

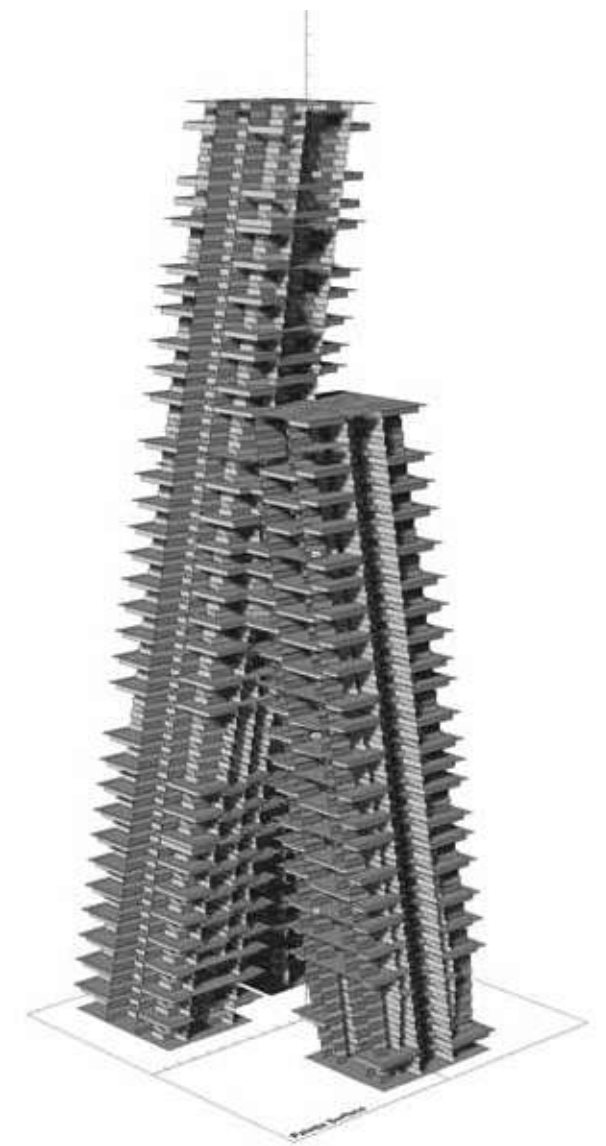

4: Final tower

Design

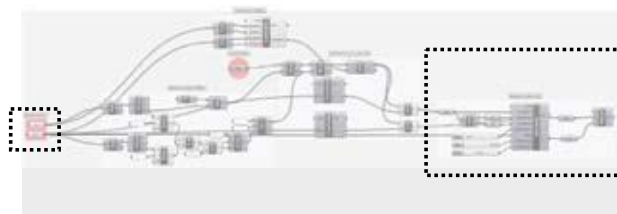

Reference floor plans
42 Components
4 Python components

Generate walls and beams
(Python component)

Robot programming: wall and beam bending



67 Components
4 Python components
1 Custom component referencing
robot programming library

Generate bending instructions
(custom component)

Design and robot programming: facade

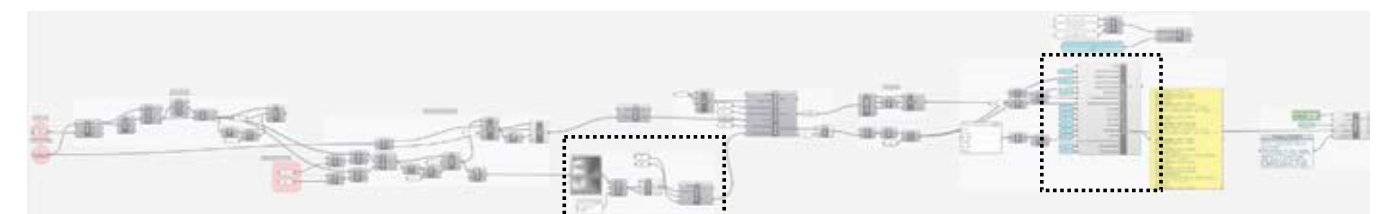

85 Components
6 Python components
1 Custom component referencing
robot programming library

Generate facade pattern
(image sampler)

Generate bending instructions
(custom component)

Design Concept

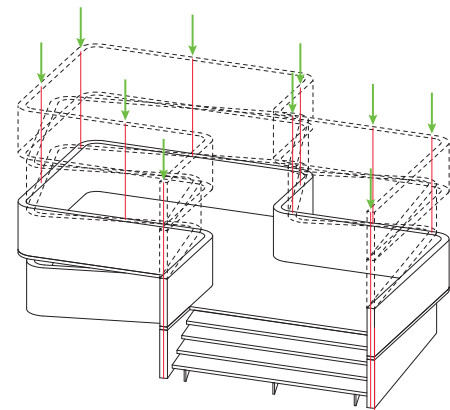
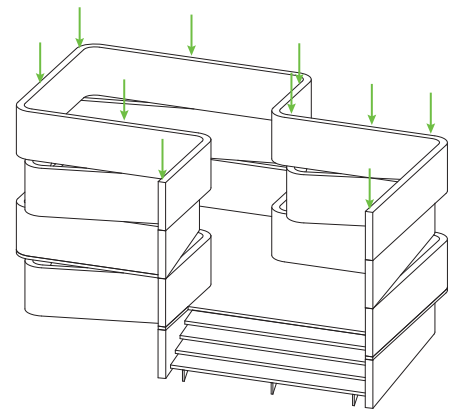
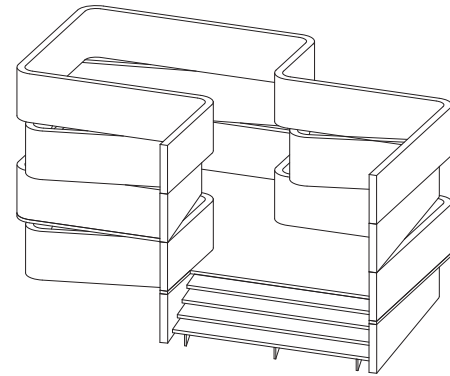
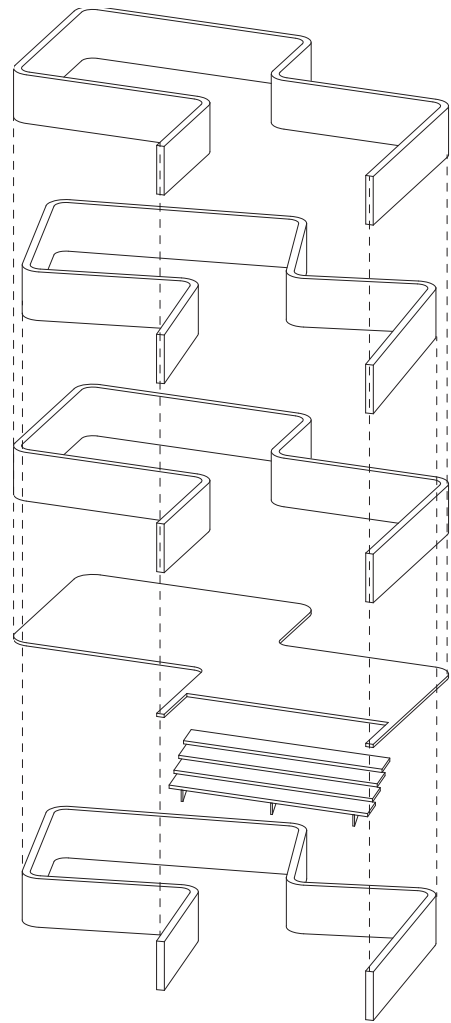

The elements are stacked in a way that allows vertical loads to be transferred at specific intersection points

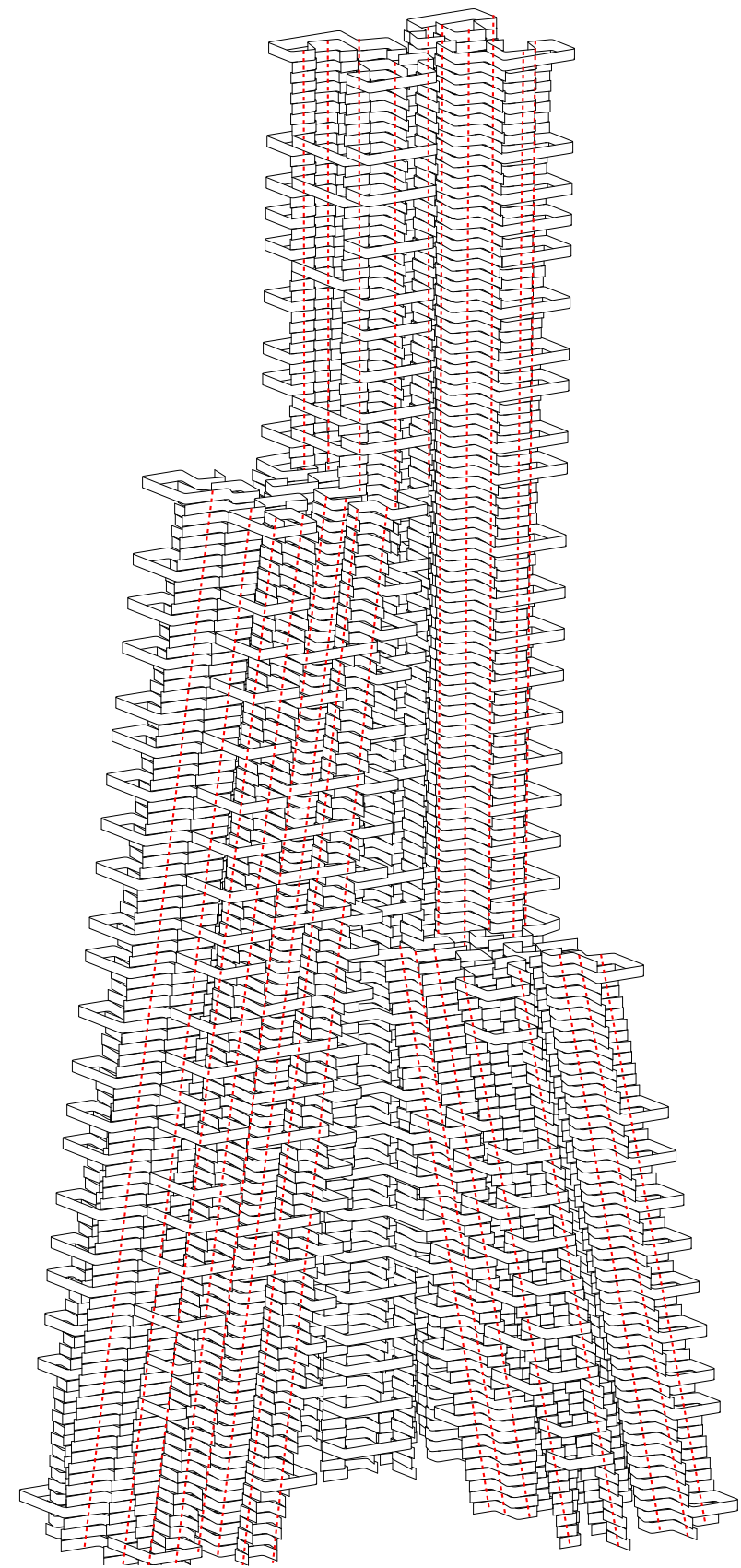

Axonometric view of the whole tower: the red lines indicate the force lines

Design Concept

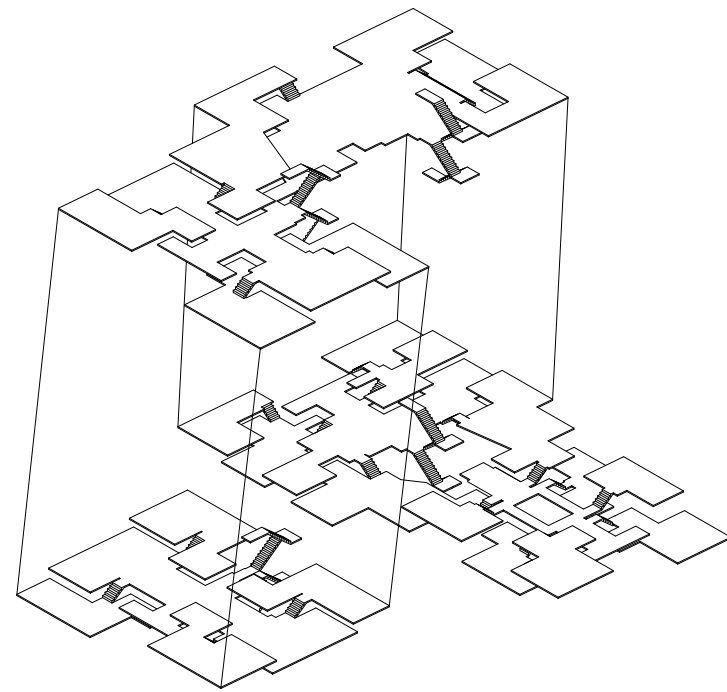

Split-levels

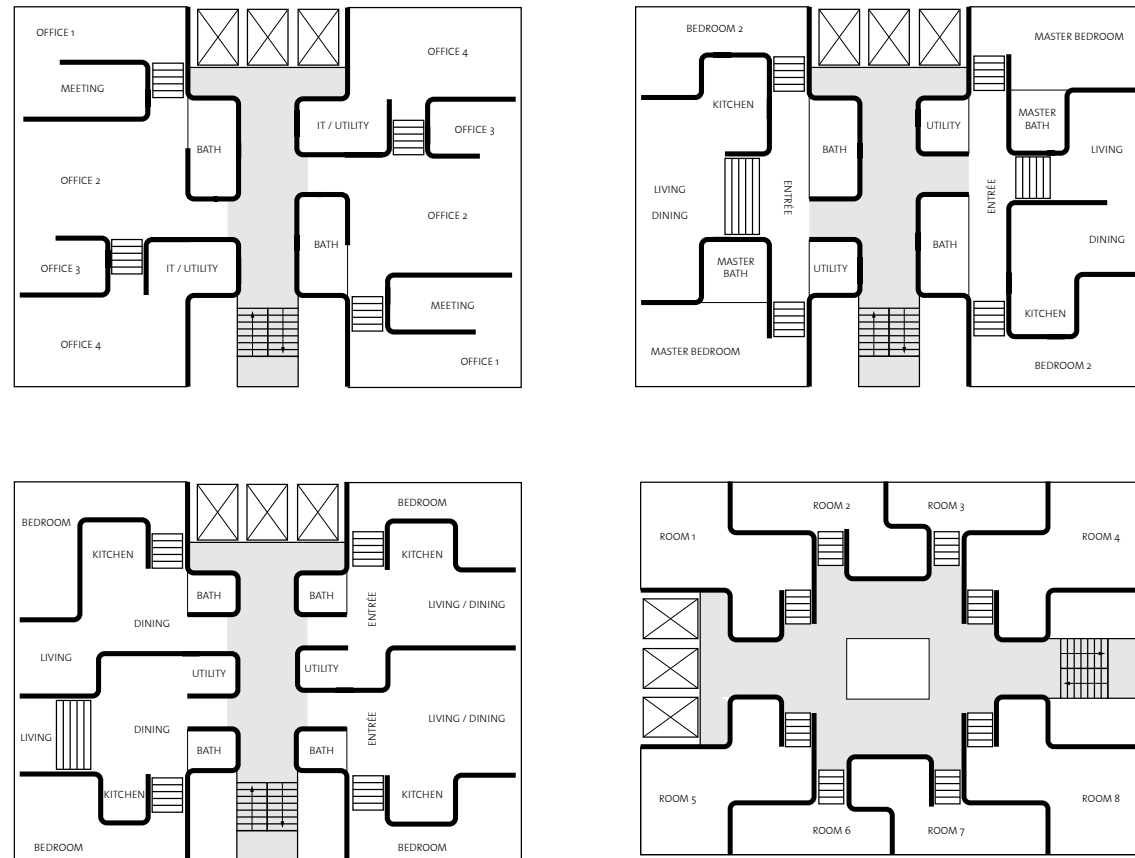

Floor plans of different tower zones showing office spaces, residential floors and hotel rooms

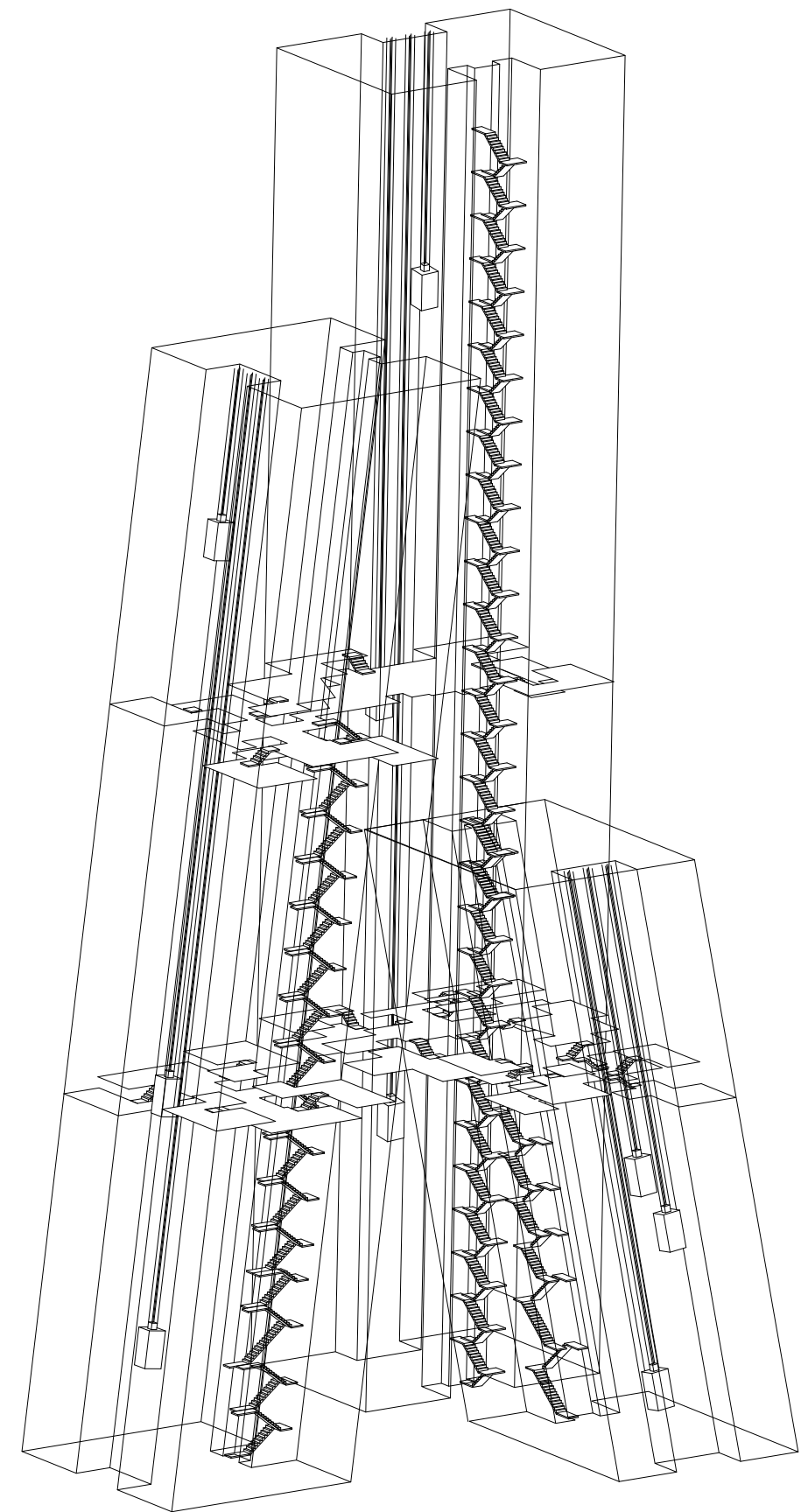

Axonometric view of the tower with the individual circulation systems

Design Concept

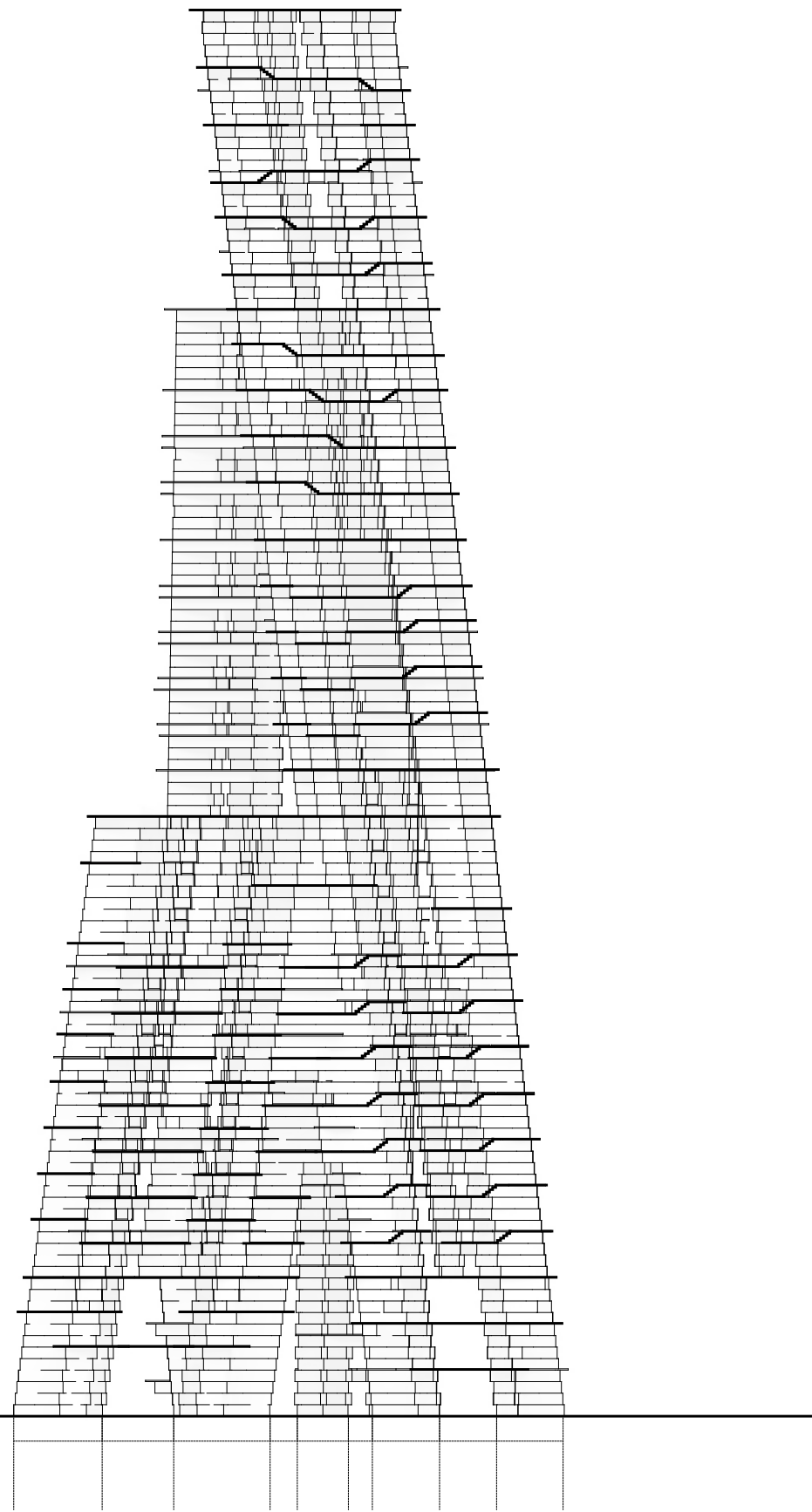

Cross section



Final tower model

Peliminary Design Studies



The first series of experiments with separate cores: an earlier version (left side) consisted out of stacked rectangles, which allowed horizontal floor slabs of various shapes to be interlocked. A later version (right side) demonstrates how a similar set of elements can be both vertically stacked and cantilever out to provide horizontal planes



Peliminary Design Studies

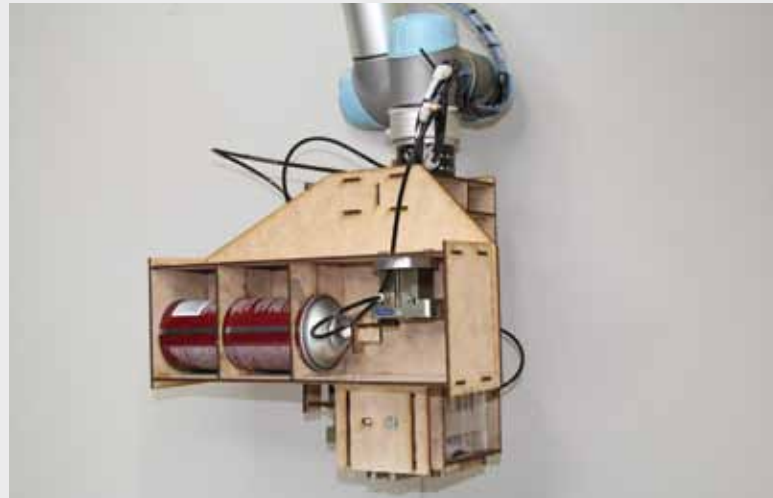

The gripper setup contains a gluing device to automate picking, placing and fixation

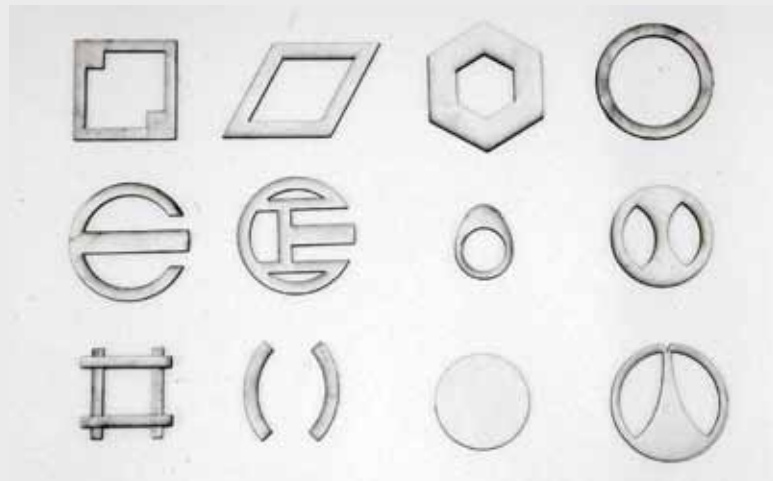

Evolution of individual components to optimise for horizontal cantilevering



Component placing at the start of the robotic assembly process

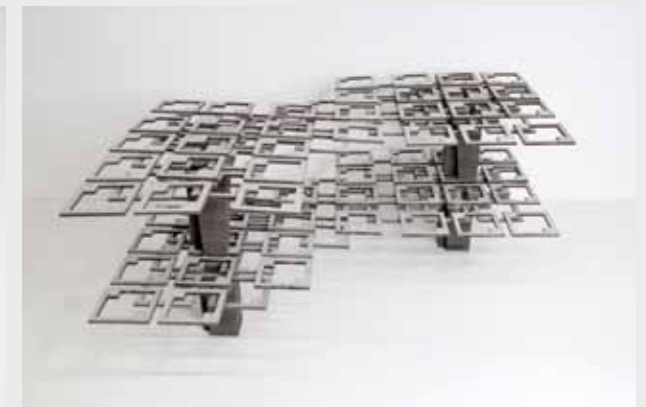
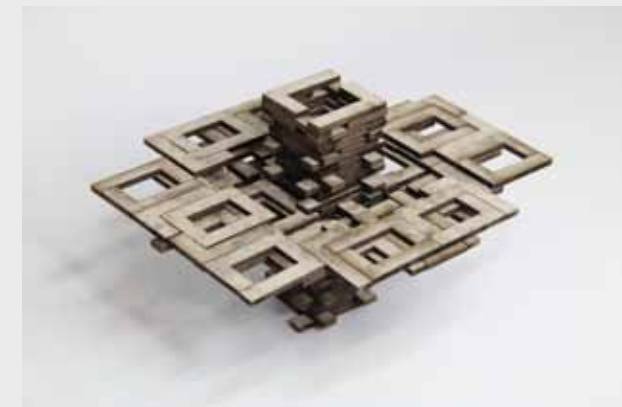
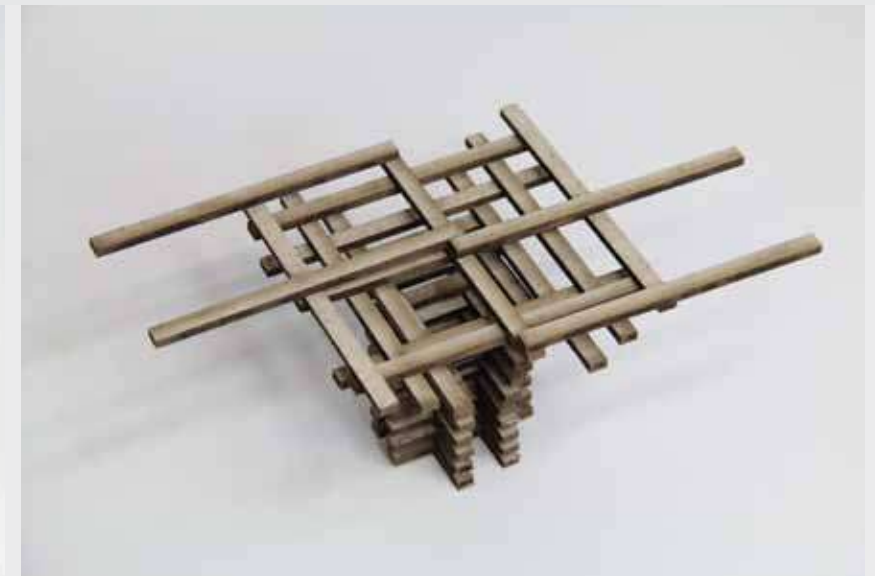

Various study models and close-ups of the tower studies: outrigger systems inspired the development of components that could be both vertically and horizontally assembled in a continuous process

Preliminary Design Studies

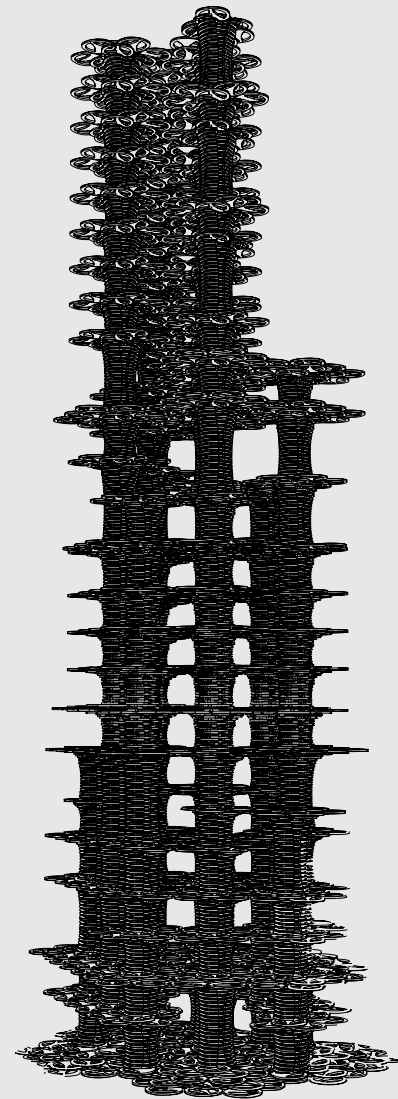

Wireframe of the tower study.

15.574 parts

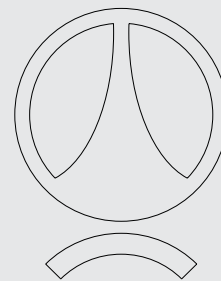
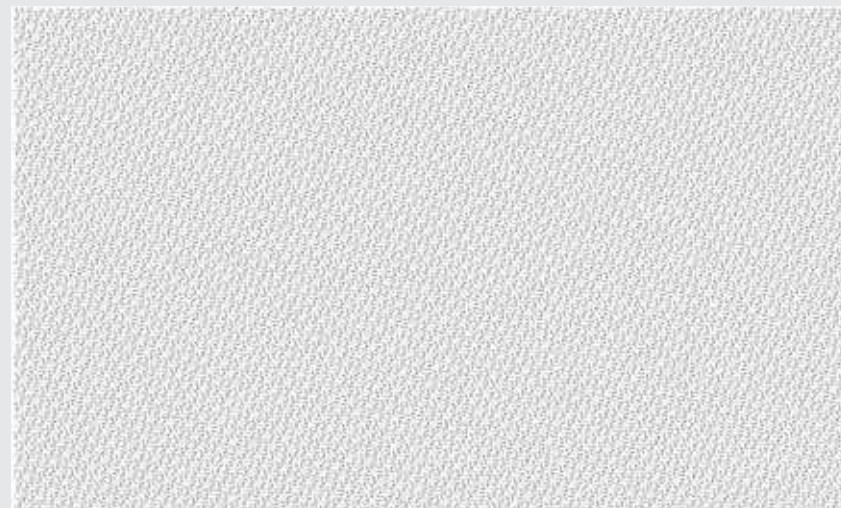

The last of the preliminary towers is assembled out of 15.574 parts and two different types of individual components

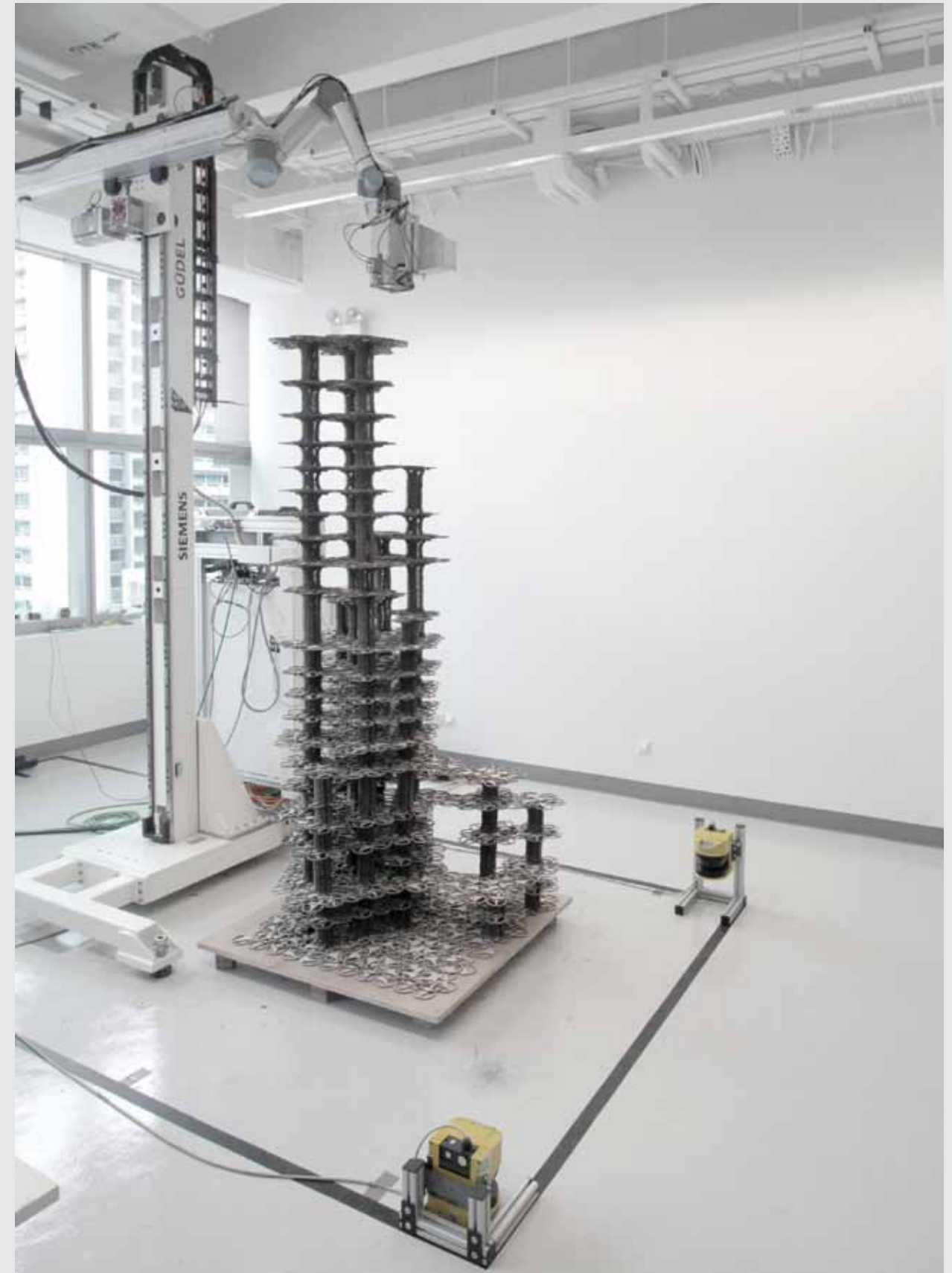

The tower study after completion of the robotic assembly process. The tower consists of several cores, which merge on various levels to stabilise each other

Tooling

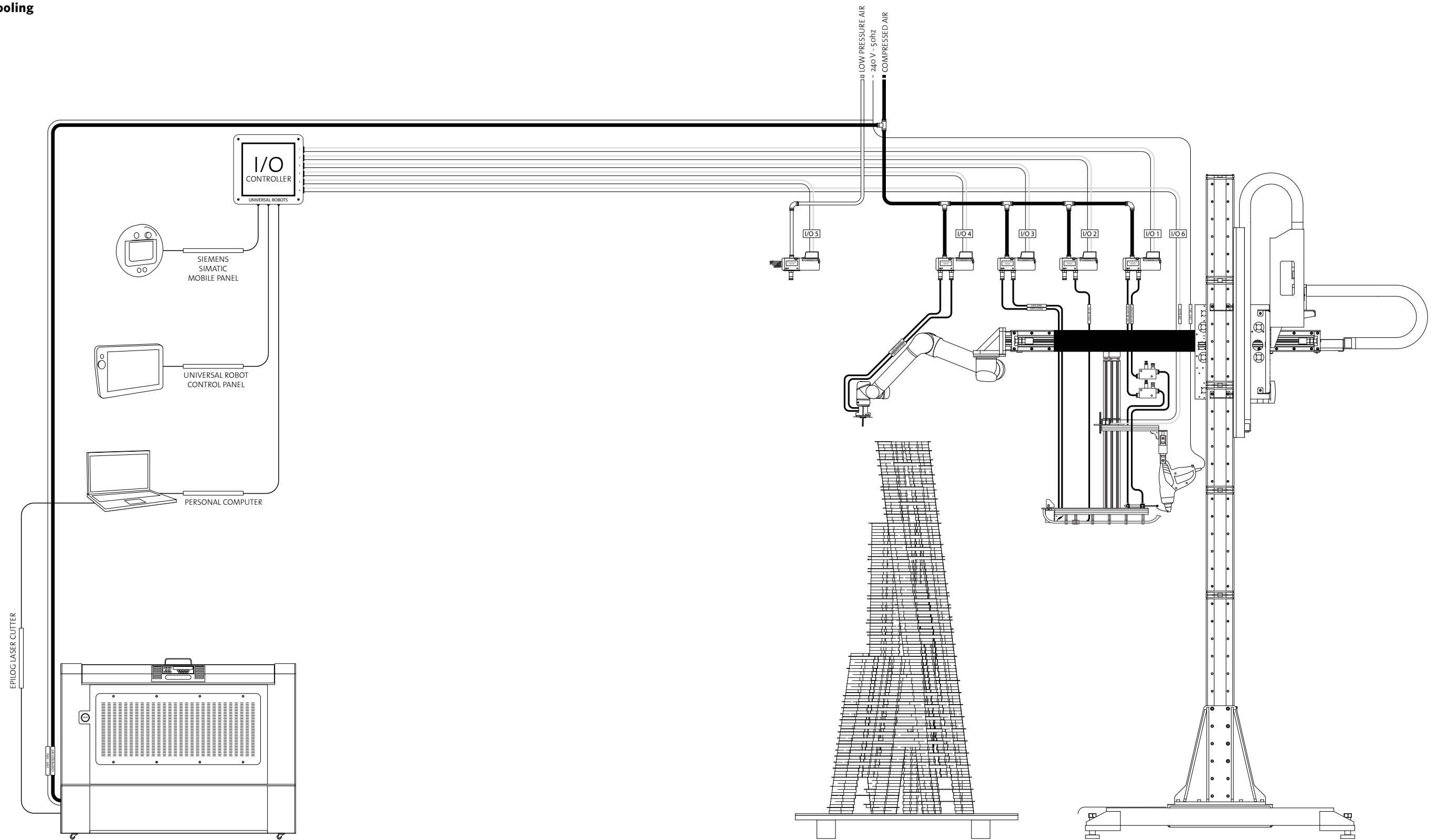

Fabrication Process

1: The acrylic stripes are fixated in a linear rail and pushed forward until the bending position is reached

2: The material then gets heated to 560° for 11 seconds

3: The robotic arm can now bend the material to any angles between 0° and approximately 160°. After the heat deformation the plastic material gets cooled by the air pressure system in order to assemble it onto the model

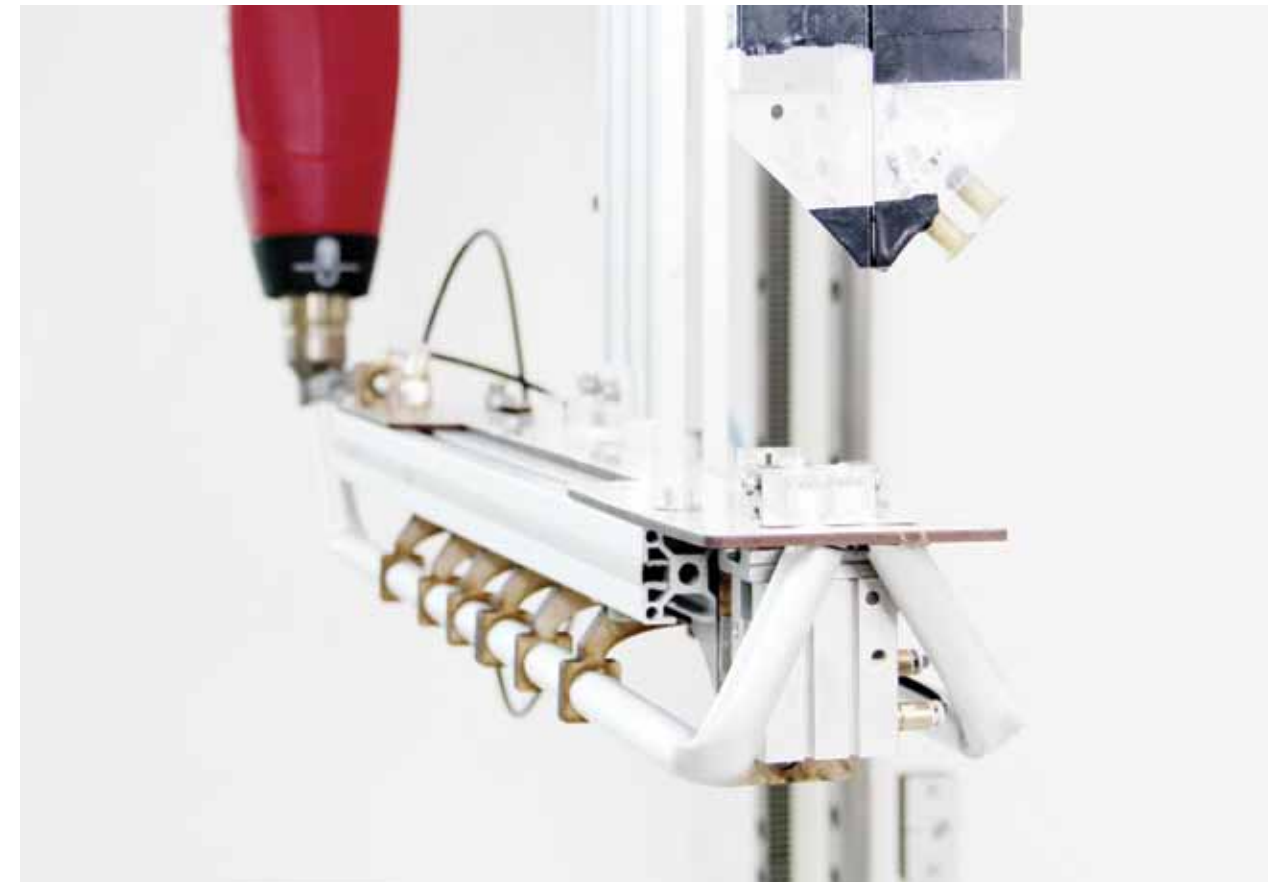

A close-up on the robotic manipulation setup

Fabrication Process

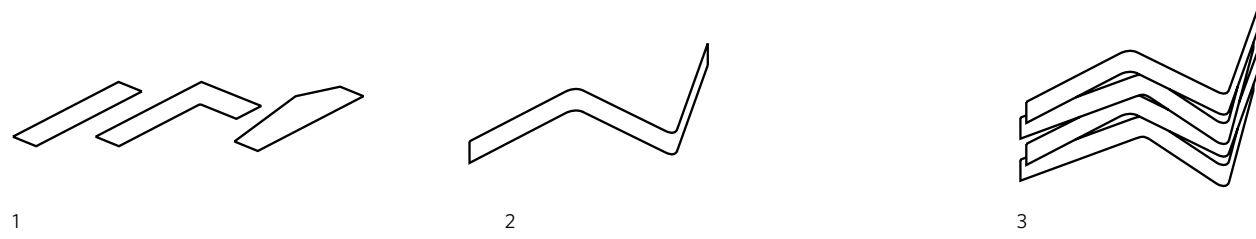

1: Two-dimensional, generic acrylic stripes are produced by the laser cutter

2: The acrylic stripe gets folded at various points and can thus be assembled in an upright position

3: The stripes get stacked on top of each other following a vertical order to allow structural support at specific intersection points

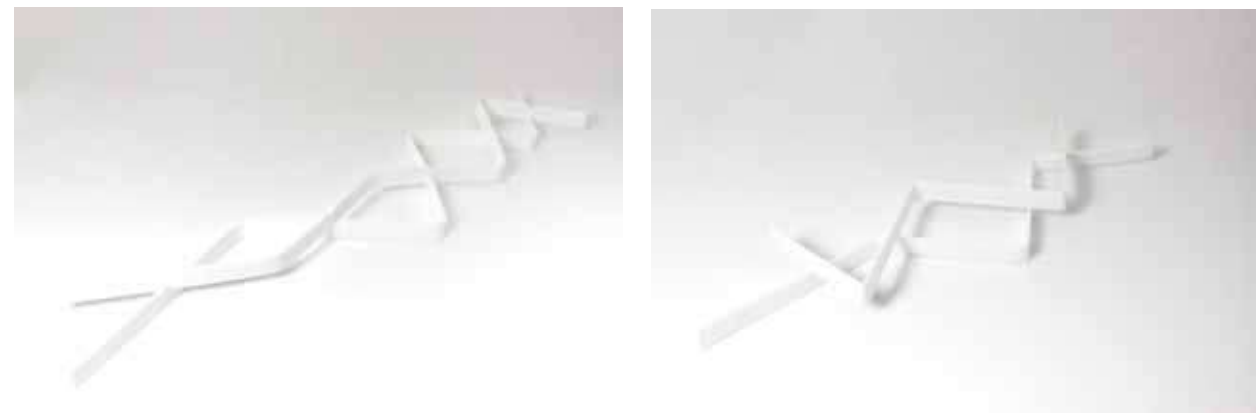

Studies of deformed acrylic stripes to test angles and bending positions

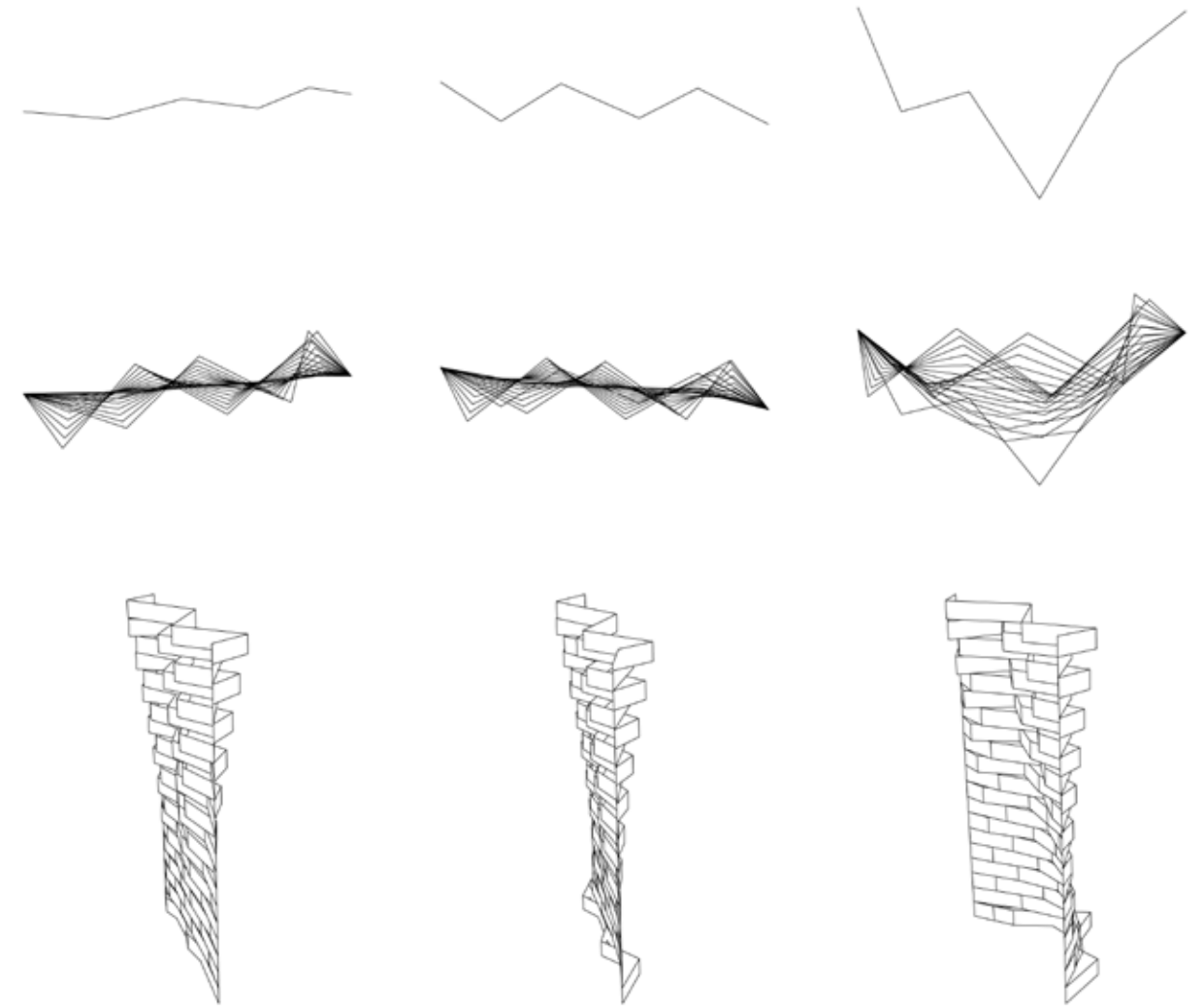

Bending angles can vary over the height of the assembly and thus generate vaulted and deflected walls

Fabrication Process

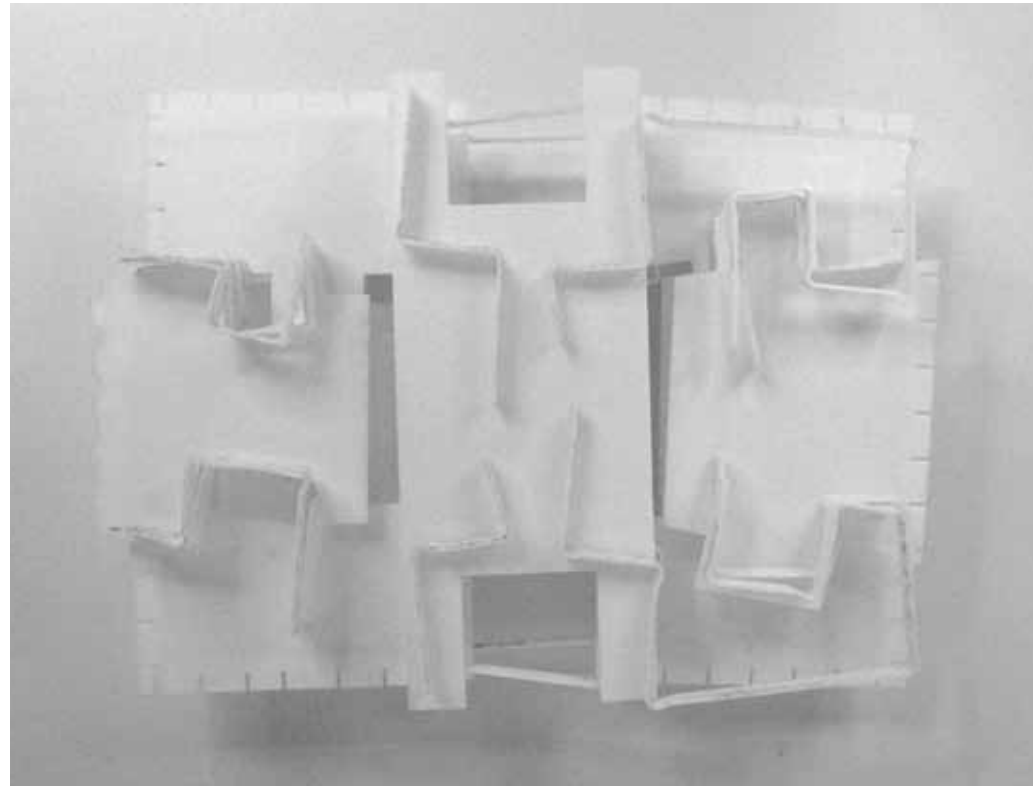

An earlier study model, where combinations of different wall-floor arrangements are investigated for their architectural capacities

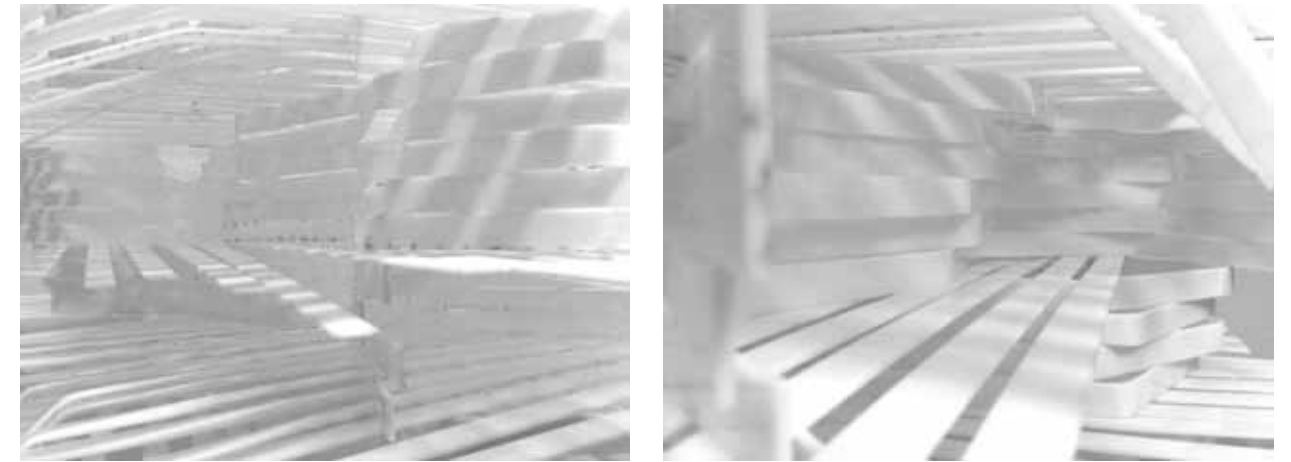

Interior perspectives

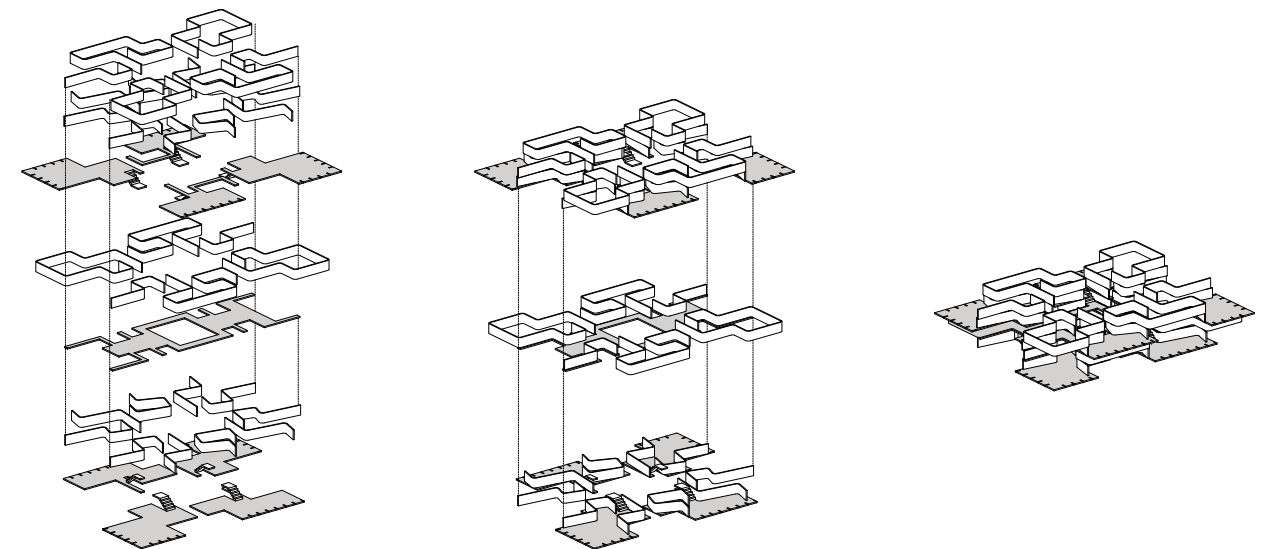

An axonometric visualisation shows how the three-dimensional array can be altered for vertical differentiation (e.g. split levels)

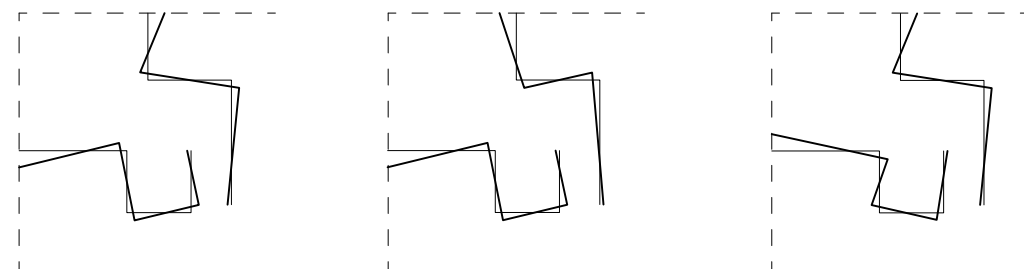
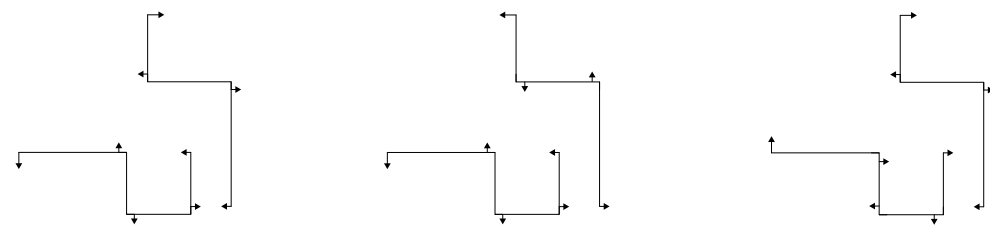

Different arrangements respond to different programmatic demands

Fabrication Process

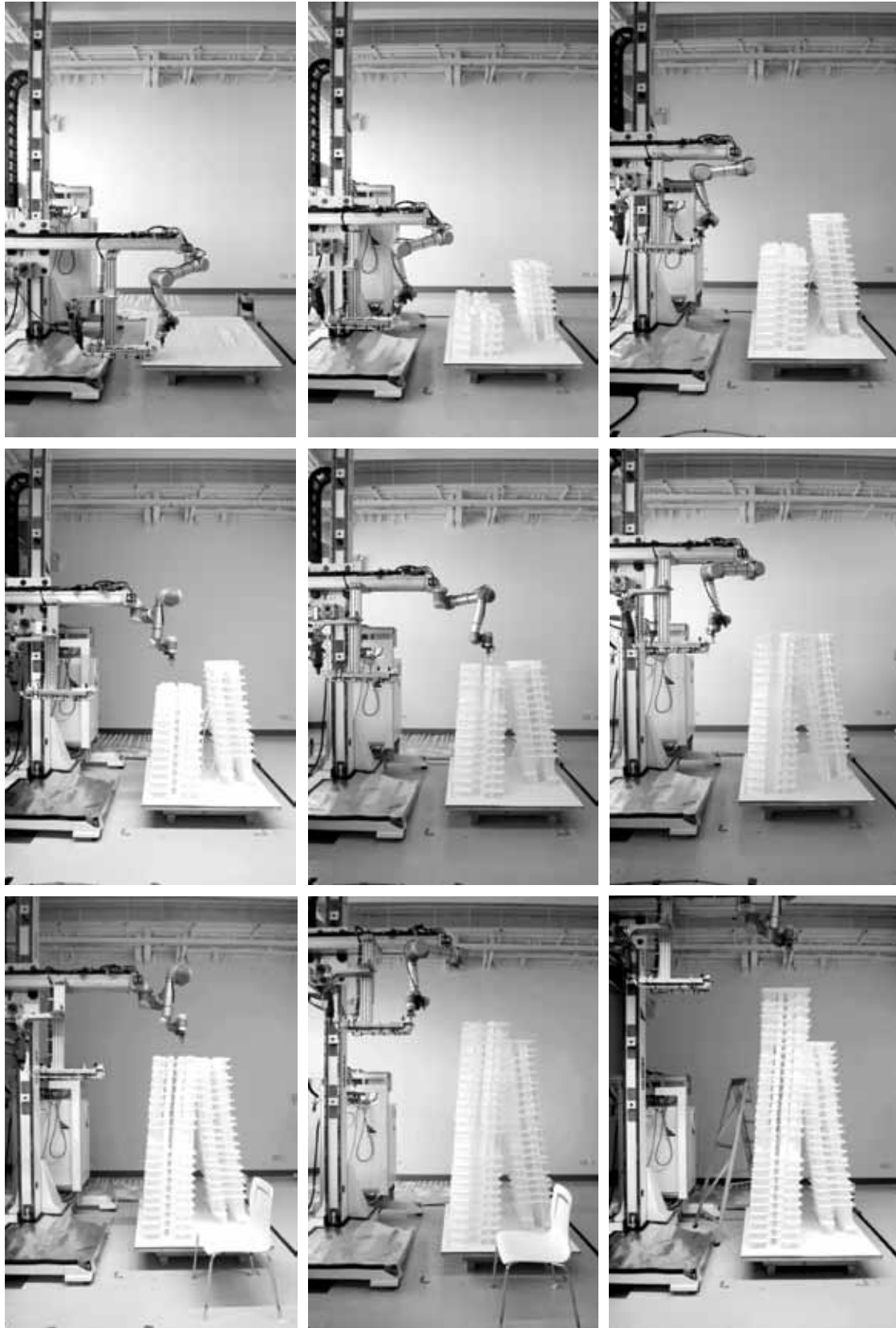



Nested Voids

Tiong Bahru Area

Students: Pascal Genhart,
Tobias Wullschleger

Focussing on internal voids as primary design driver for novel high-rise typologies, Nested Voids explores the robotic assembly of a multitude of single elements according to their vertically differentiated aggregation. In this project walls and floor slabs are structurally articulated by grey cardboard layers. The robotic arm picks them out of a laser-cut sheet and directly places them at their final position onto the tower model. The seamless digital coupling of laser cutting and robotic picking and placing processes allows for an almost unlimited degree of differentiation in the structure, which can thus adapt – both locally and globally – to specific load cases as well as to the spatial structure of void spaces. These voids organise the overall internal circulation and, in addition, provide natural light and ventilation. A second material process, consisting of the robotic twisting of acrylic preheated elements, is used to fabricate semi-transparent louvers acting as facade enclosure system and shading devices.



Computational Design

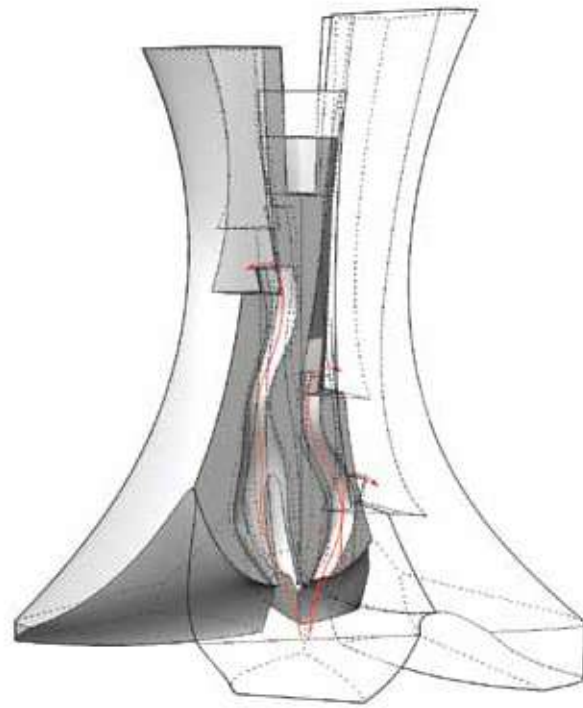

1: Generation of outer volume and inner voids

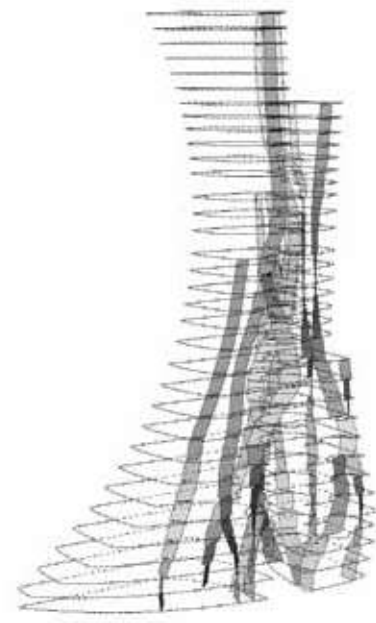

2: Creation of primary wall system

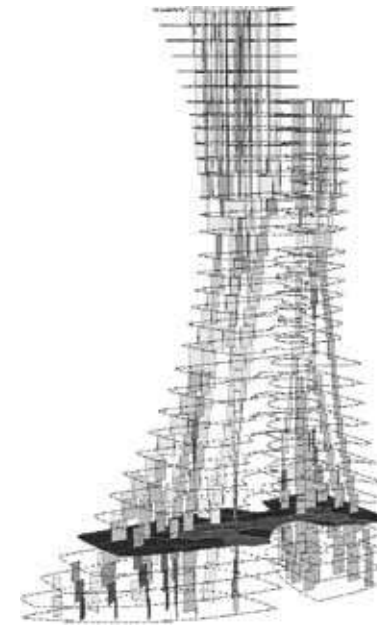

3: Generation of secondary wall system



4: Population of interior walls with informed louvers

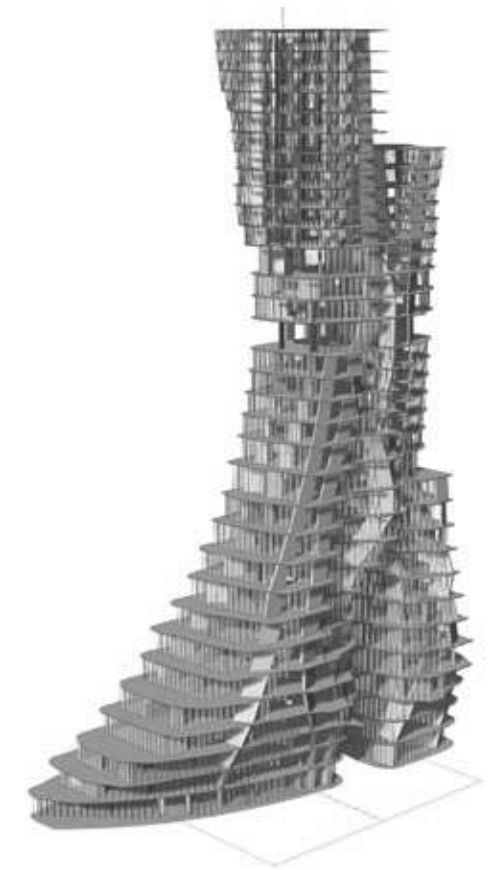

5: Final tower

Design

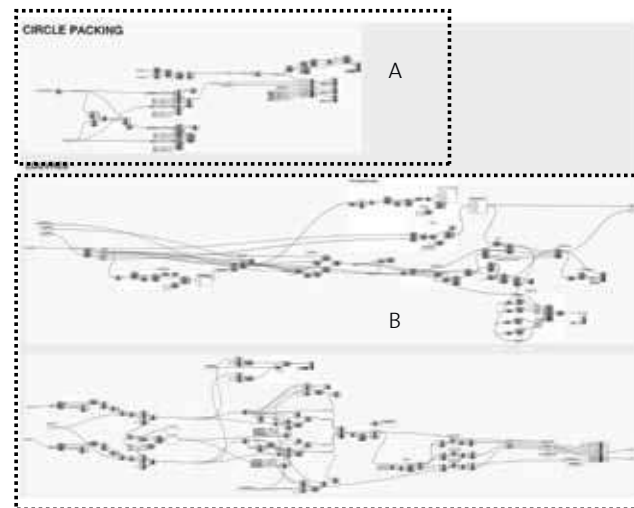

1. Generate floor system using packing logic

2. Generate louvers

Robot programming

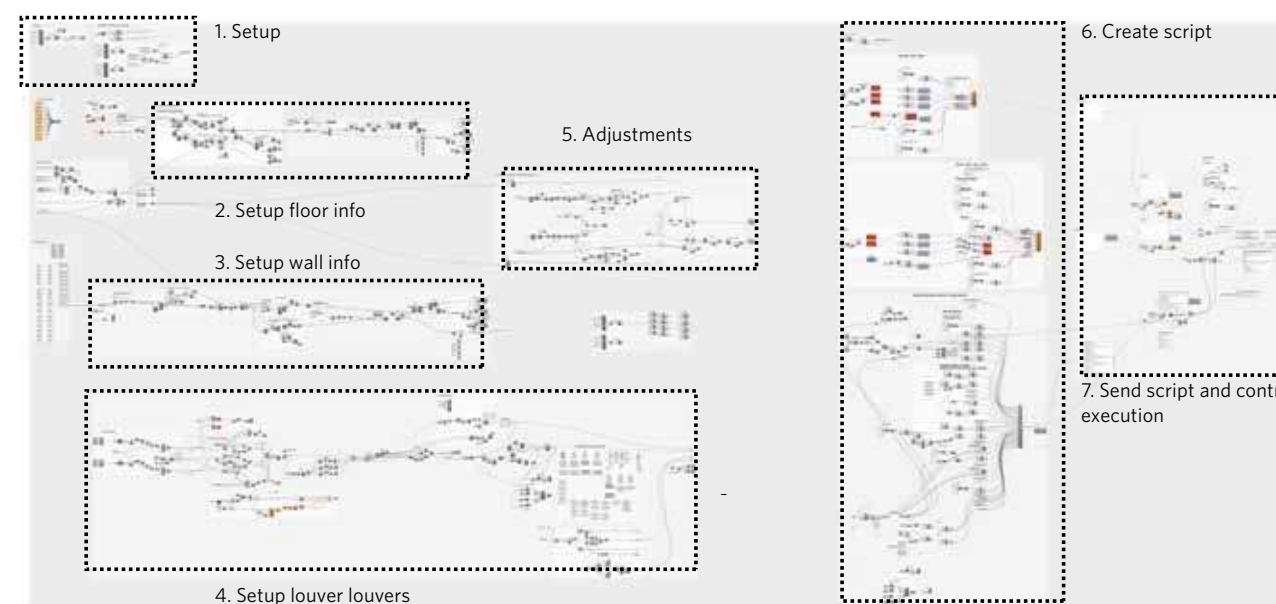

1823 Components
74 Python components
69 Components from toolkit

Architectural Concept

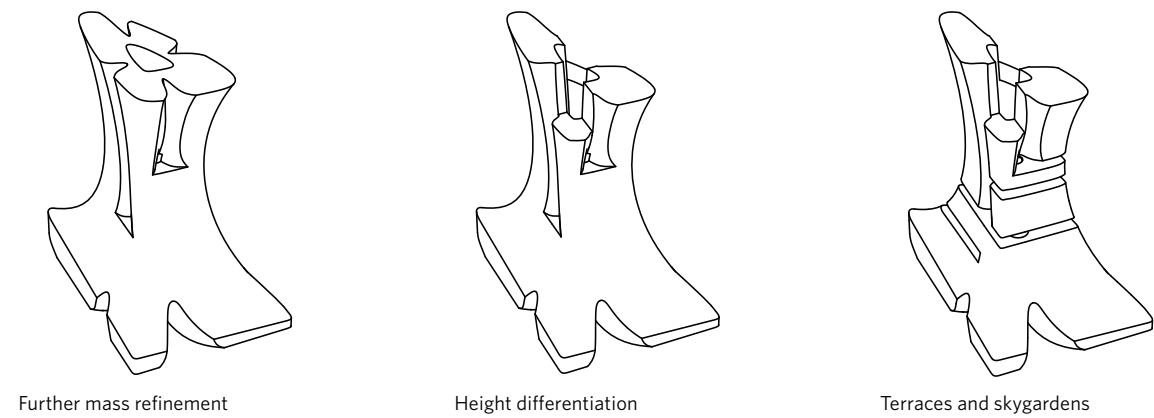
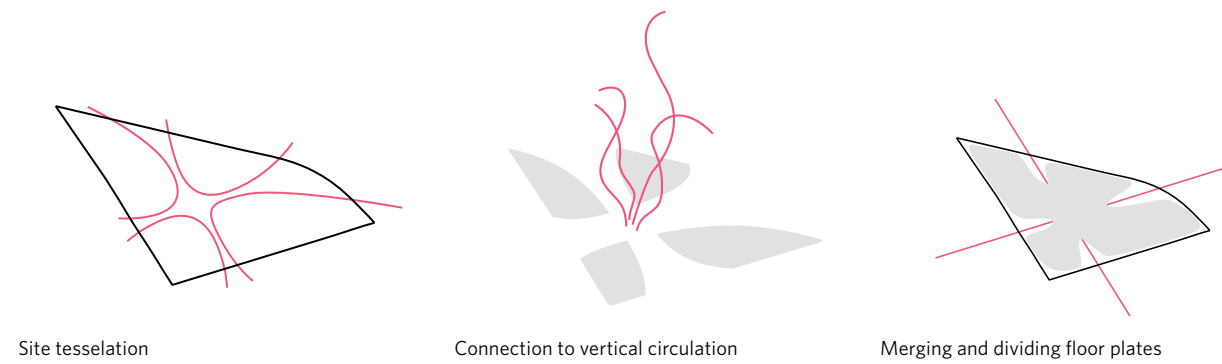
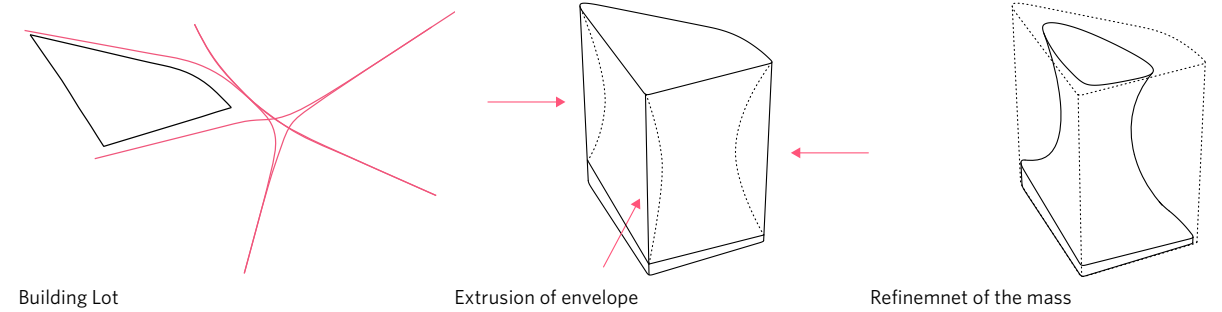

Evolution of external parameters that control the volume of the towers

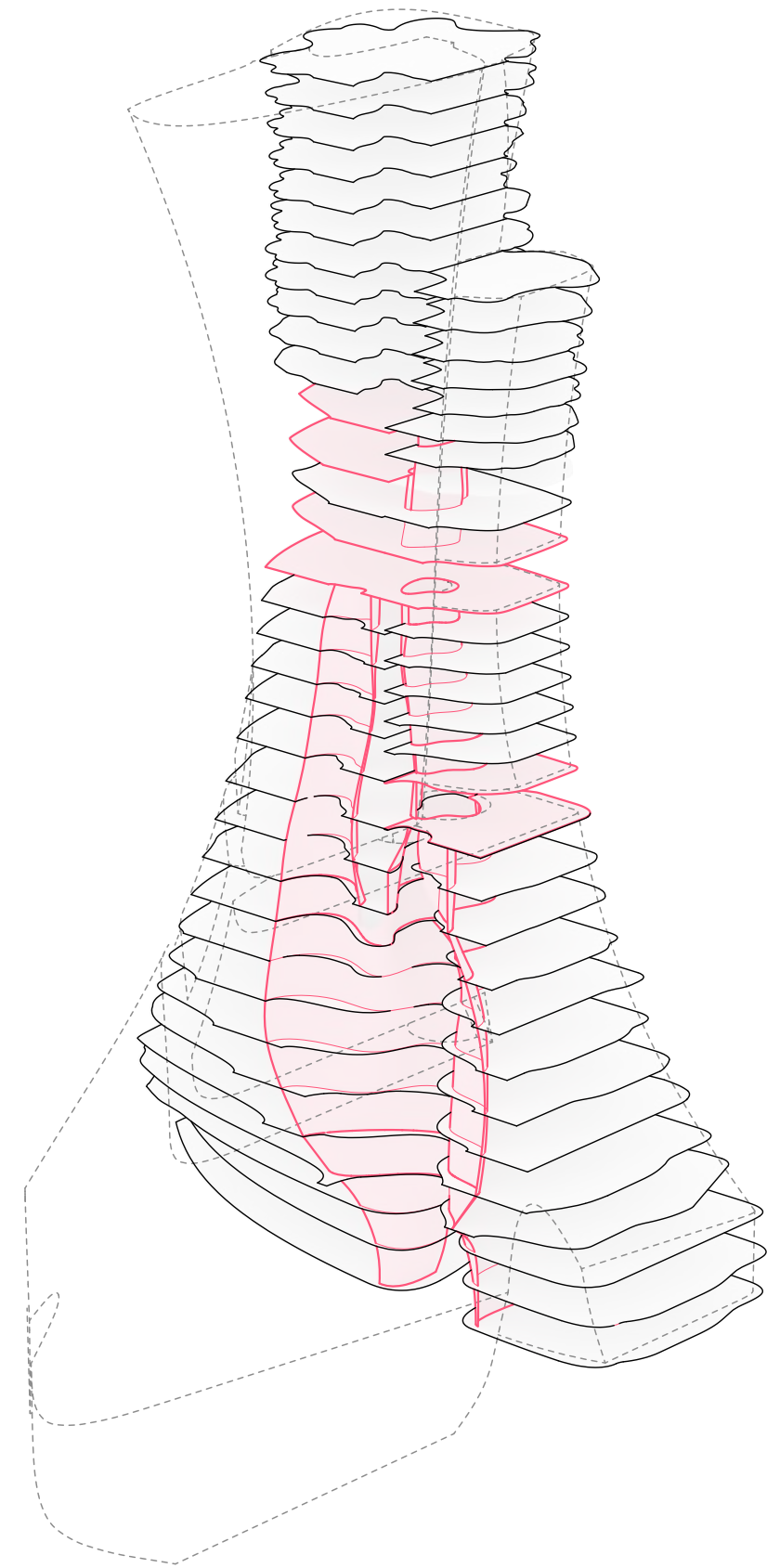

Axonometric view of the tower showing the vertically connected circulation and ventilation voids

Architectural Concept



Visualisation of the branching system, which connects vertical load bearing walls

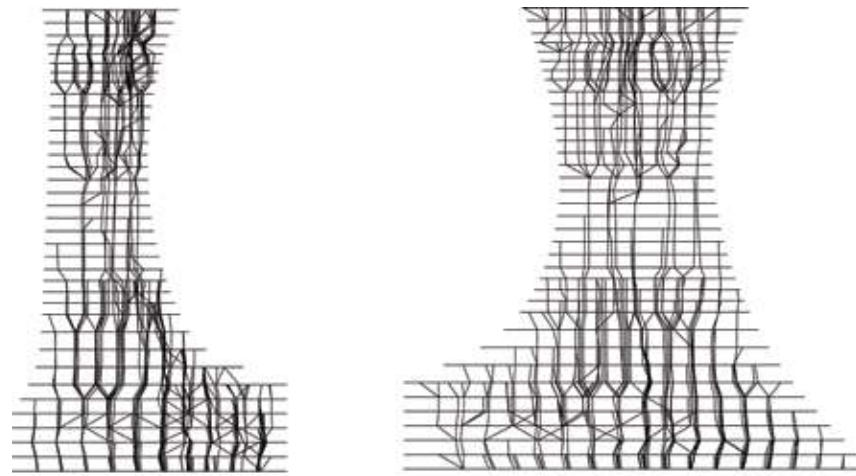

Diagrams of the structural force lines after an optimisation process

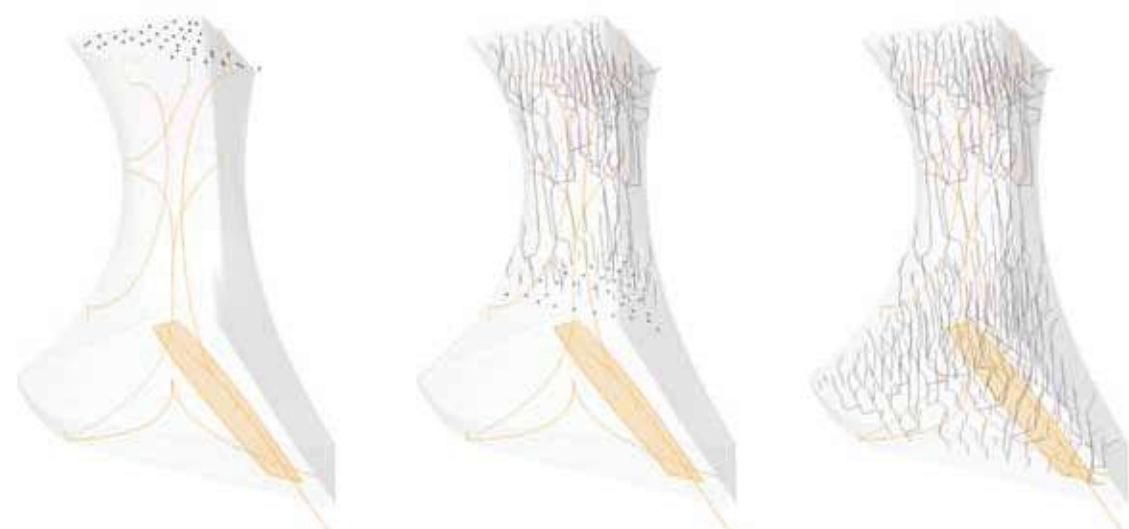

Starting from the top floor, an algorithm generates a number of continuous, branching force splines

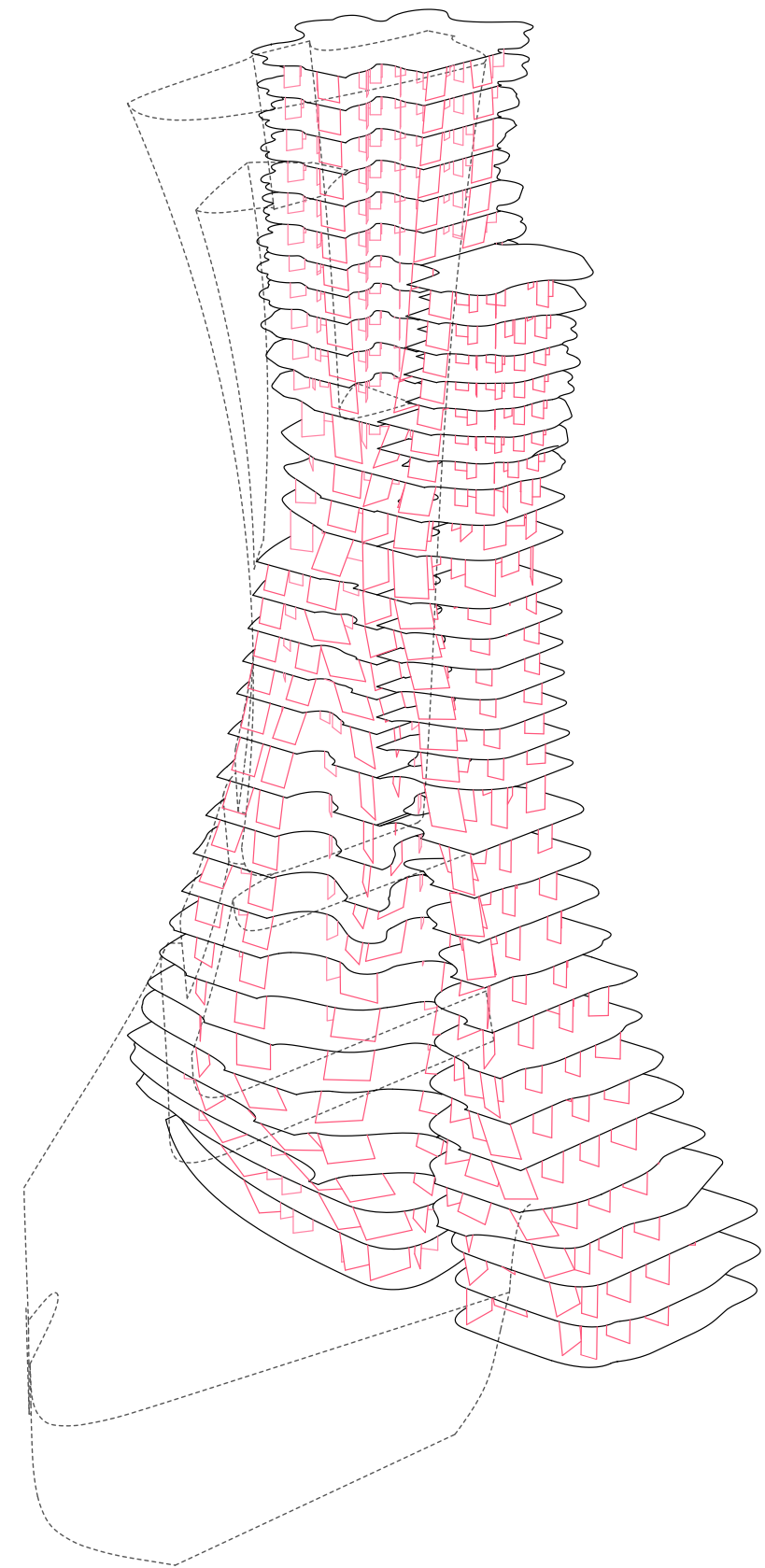

Structural system in an axonometric view of the tower

Architectural Concept

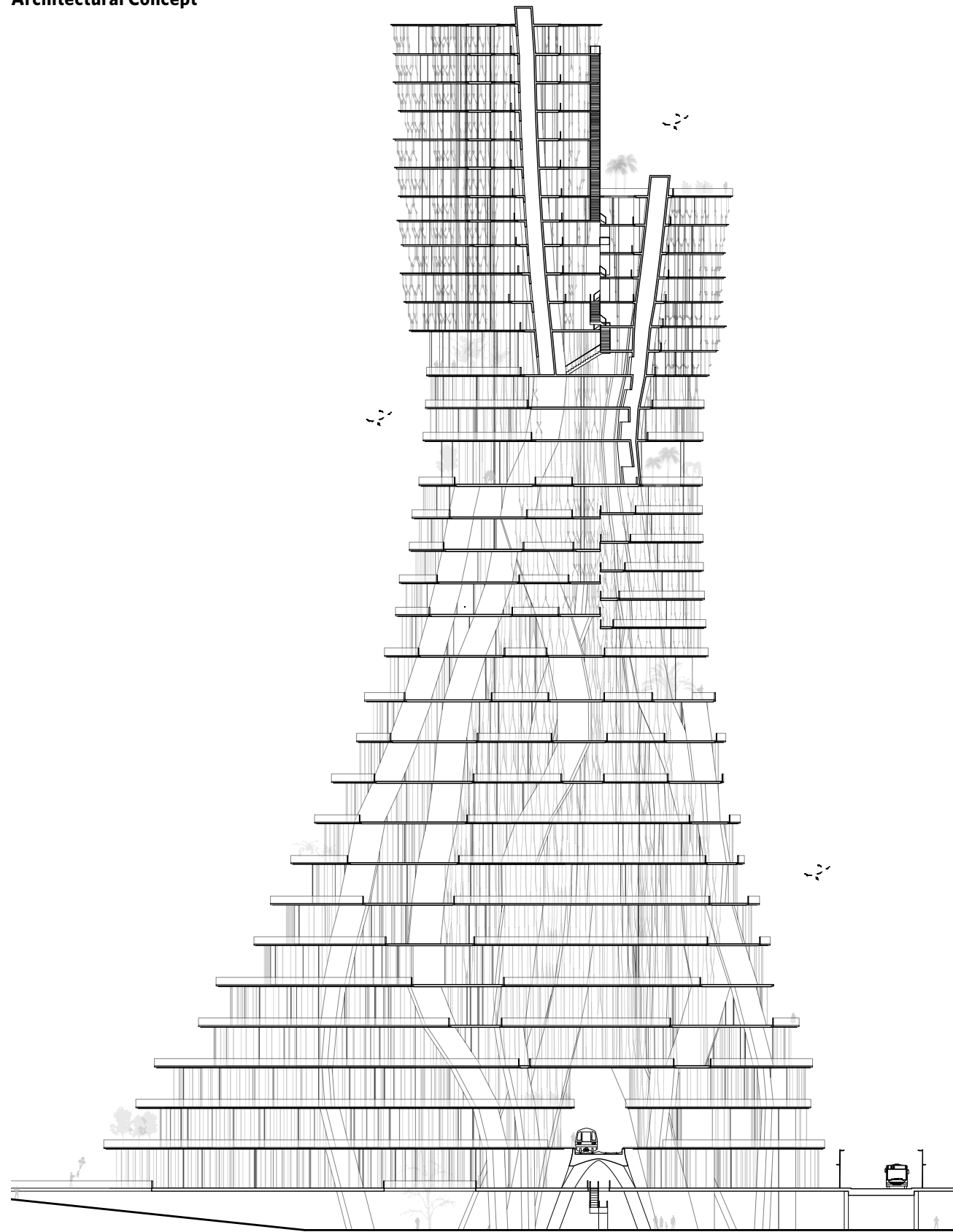

Cross section



Final tower model

Architectural Concept

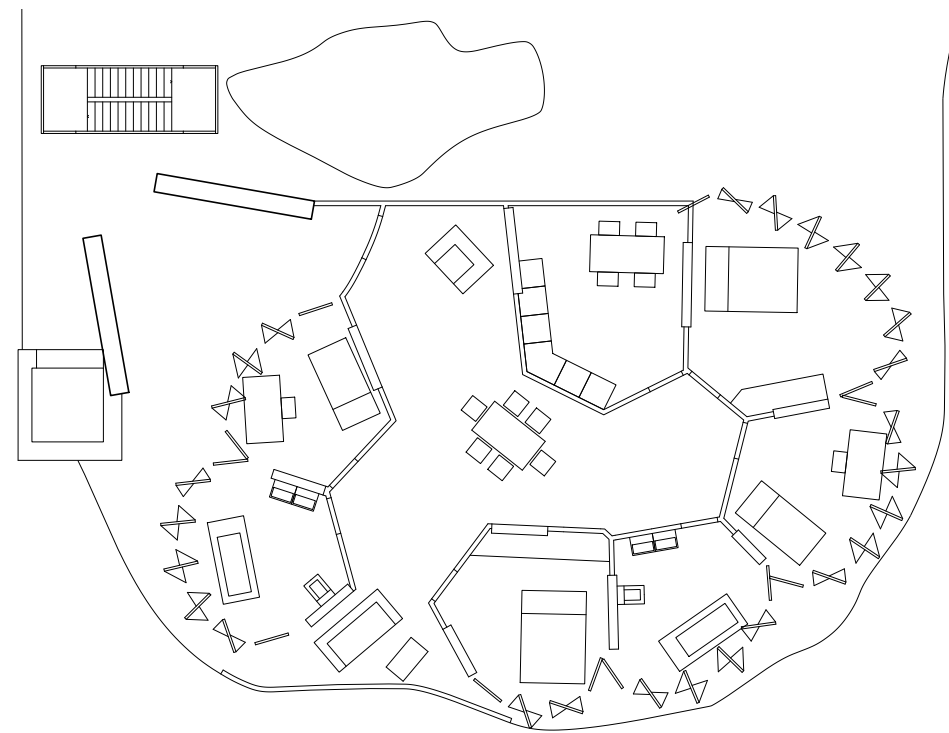
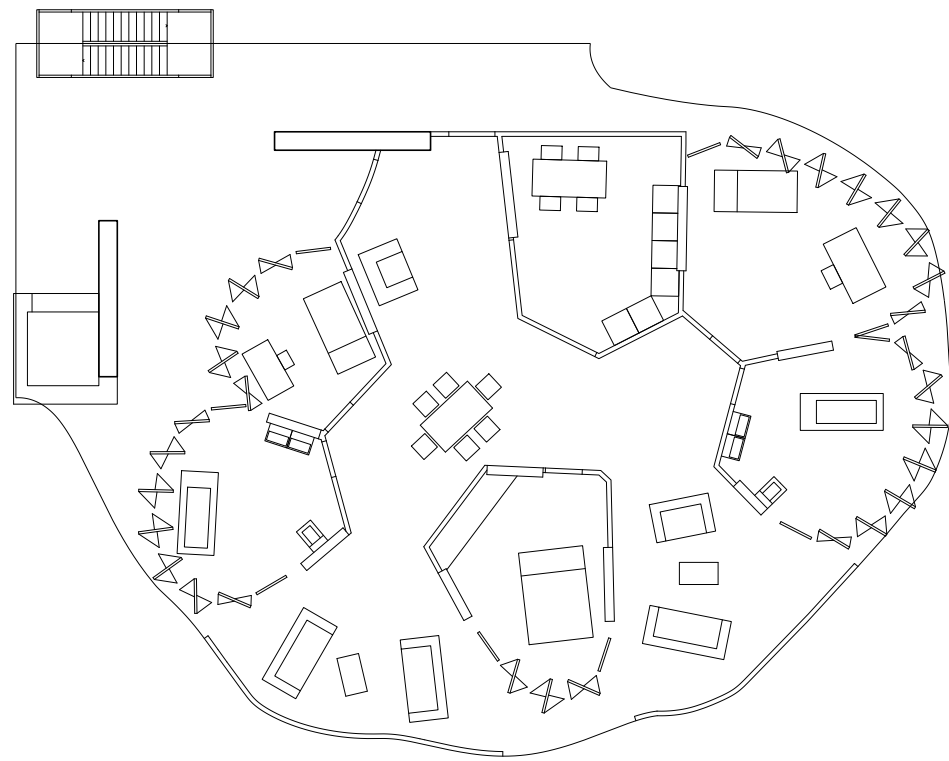

Floor plans with different configurations for residential units

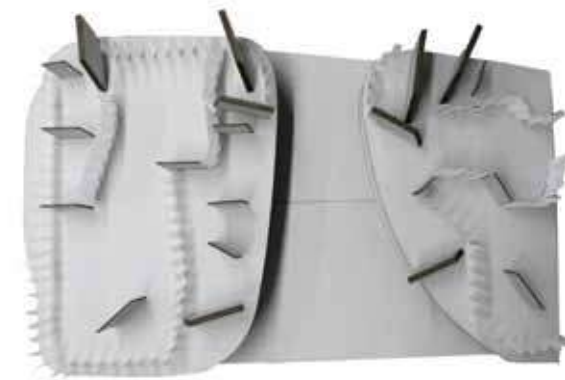

Floor configurations according to different spatial requirements, varying from large, open to smaller and enclosed spaces

Architectural Concept

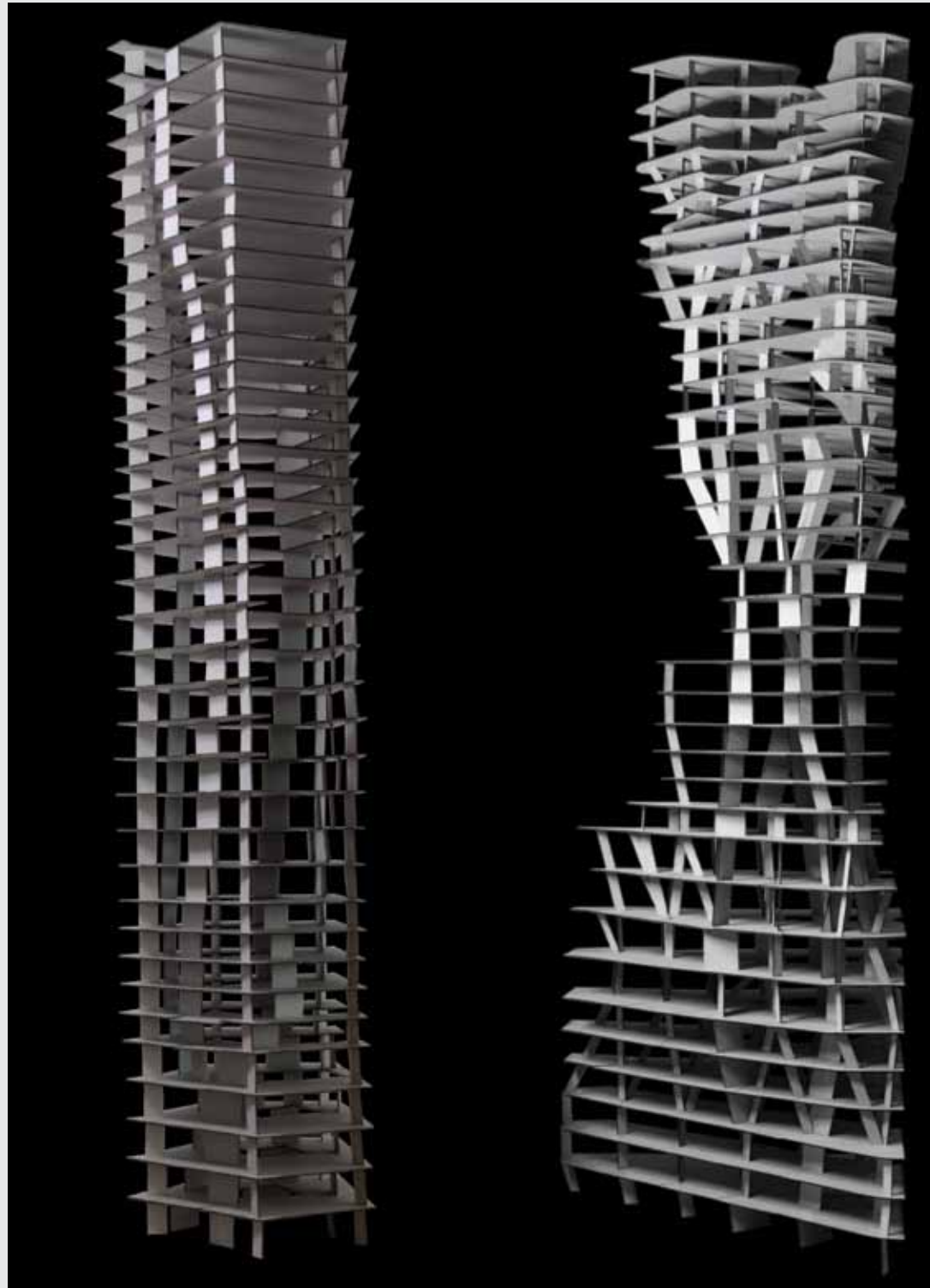

Earlier versions of the tower: a central void forms an integral part of the internal organisation

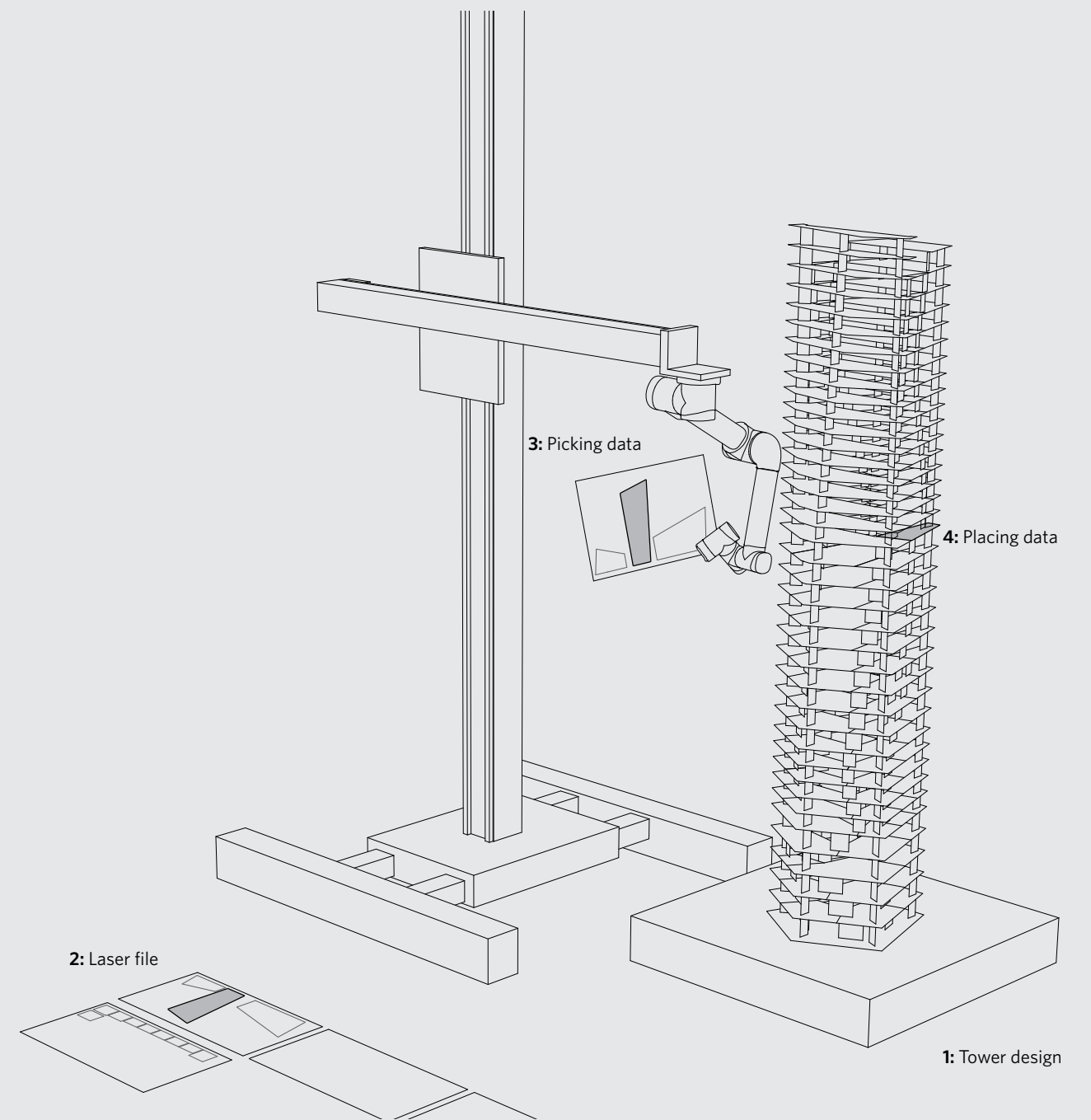

Robotic assembly: the parts of the conceived tower (1) are prepared for production by the laser cutter (2). The laser cut sheets are placed on a specifically designed feeder platform (3), from which the robot picks the individual elements and places them on the model



Preliminary Design Studies

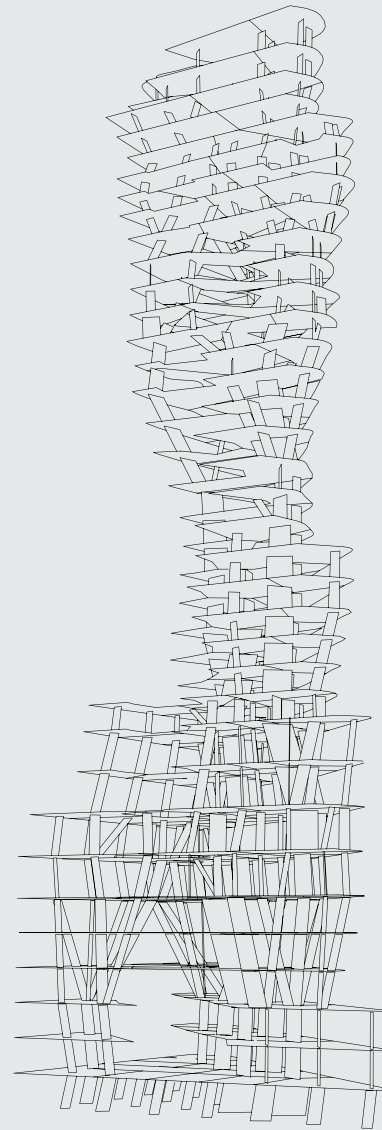

Wireframe of tower study

910 parts

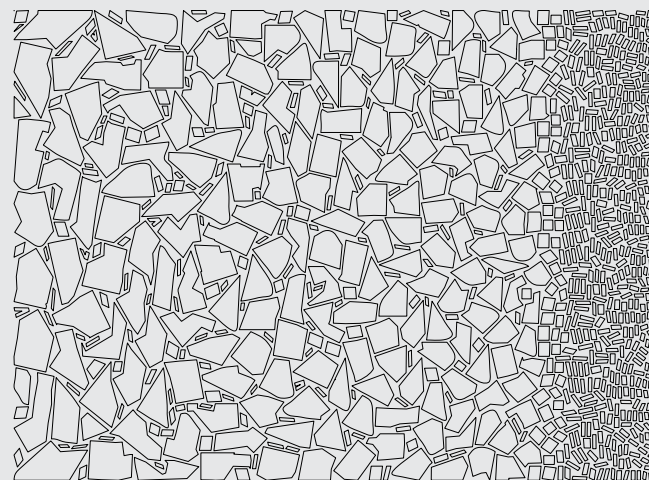

Unassembled parts of the last iteration of preliminary tower studies: the model is built with 910 geometrically unique elements

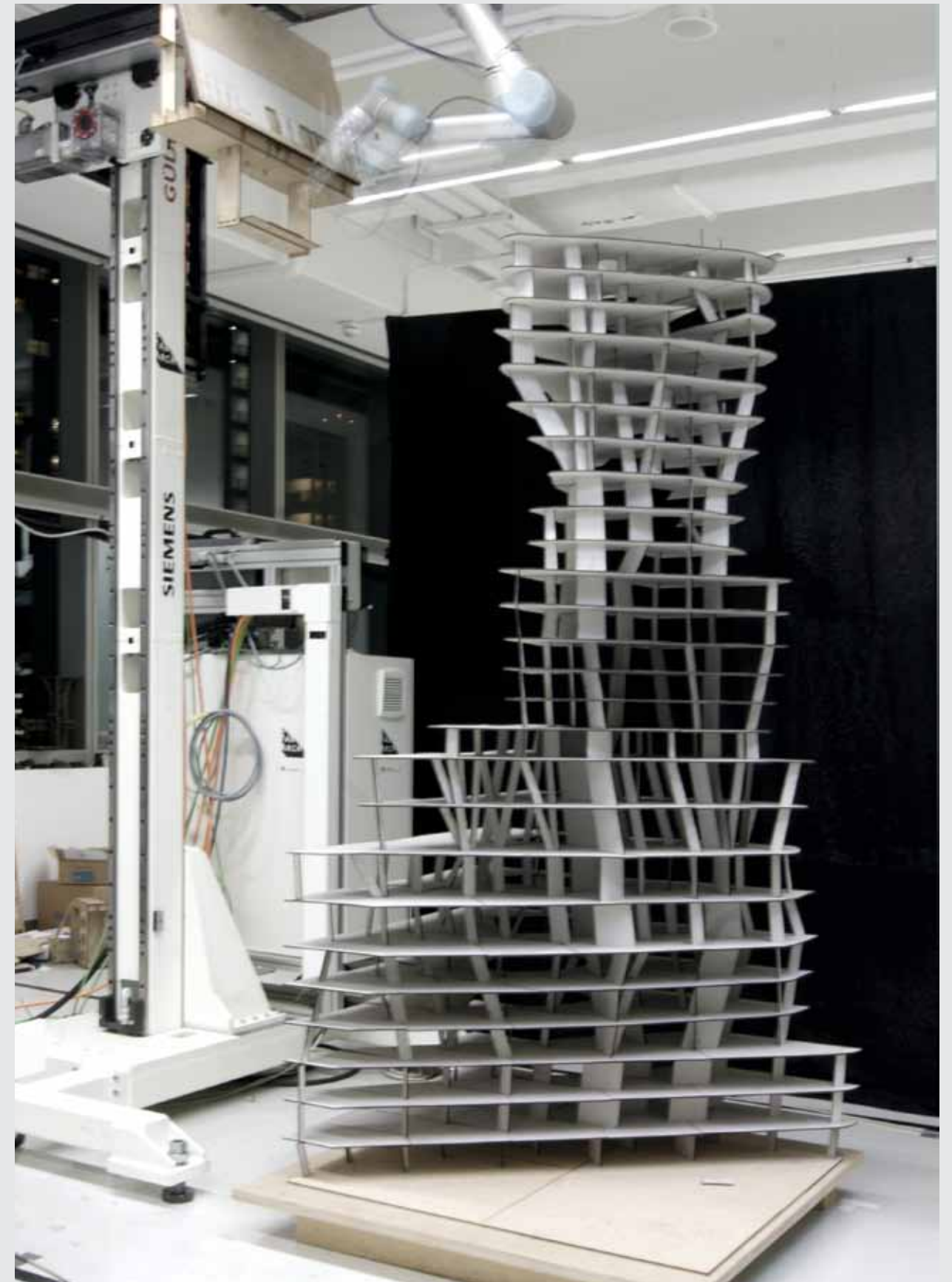

Tower study at the robotic facility. Columns and walls are organised in a system of upward branching supporting elements

Tooling

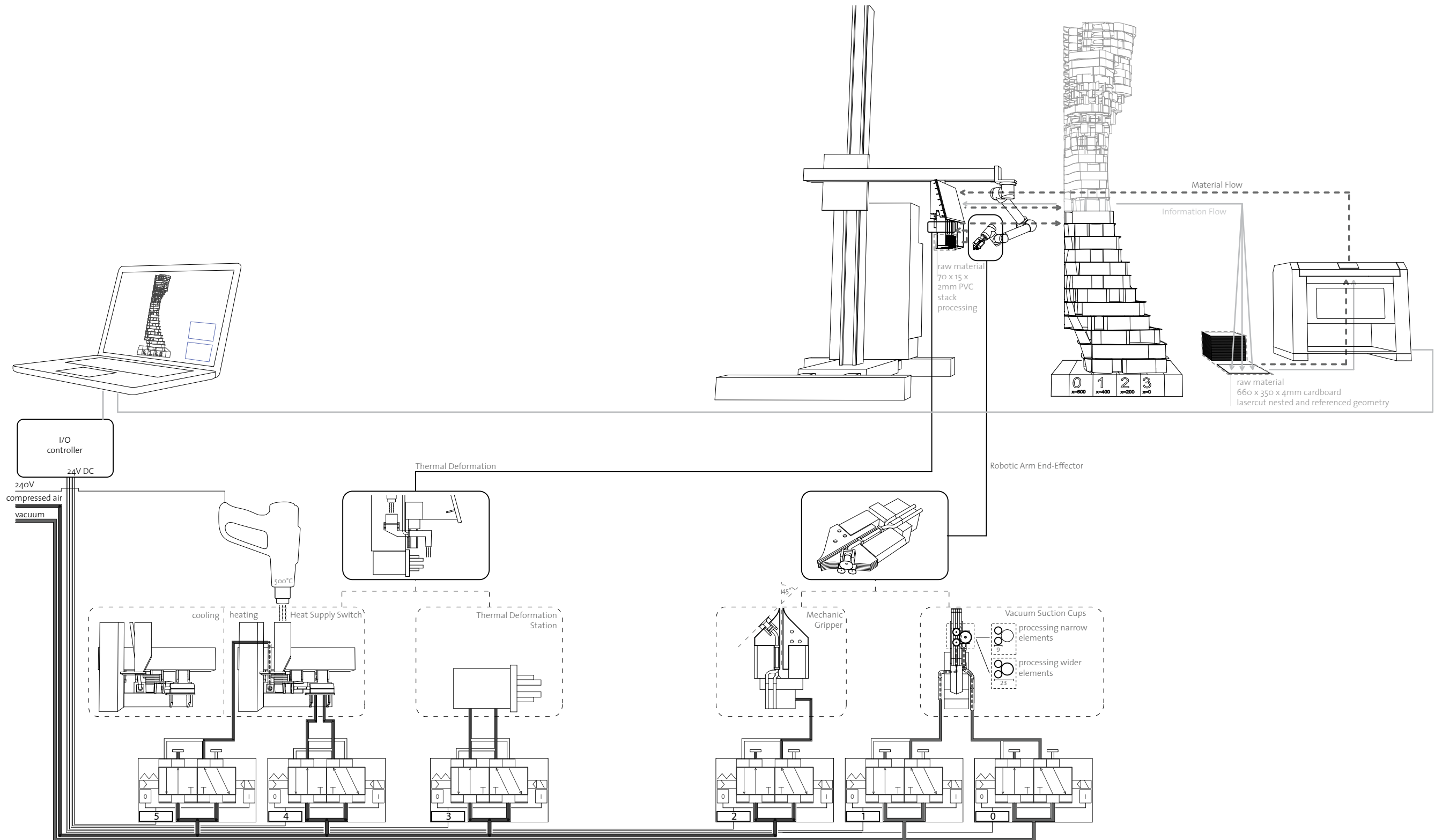

Fabrication Process

1: The transparent acrylic material is picked and placed in a clamping mechanism

2: The material then gets heated to 500° for 7 seconds

3: The robotic arm twists the element along its longitudinal axis and thus produces elements that serve as exterior enclosing systems and can be adjusted according to solar radiation

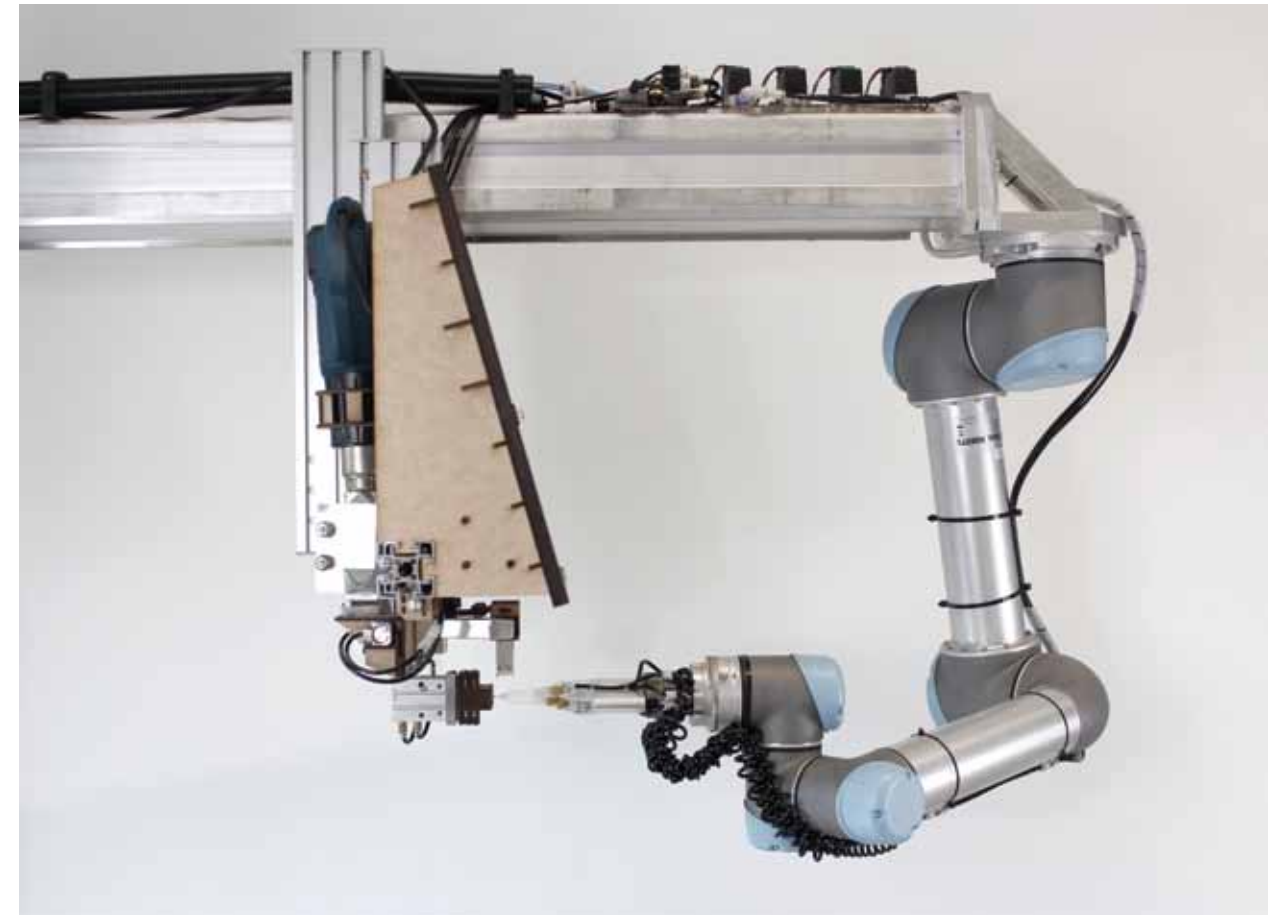
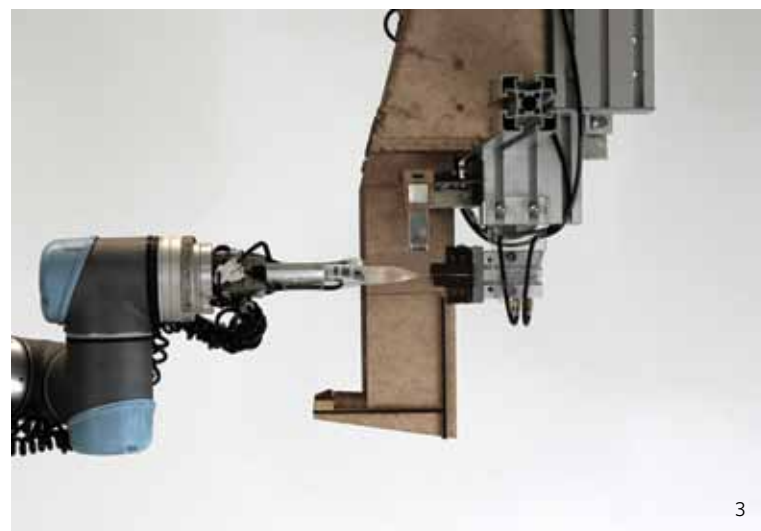
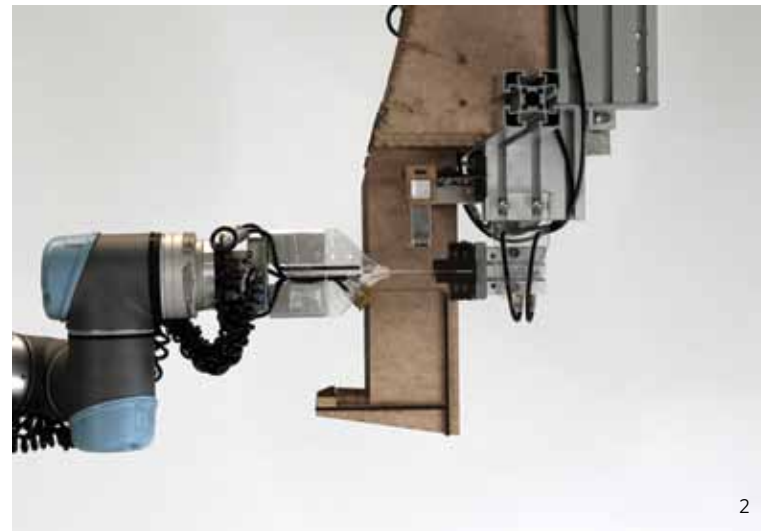
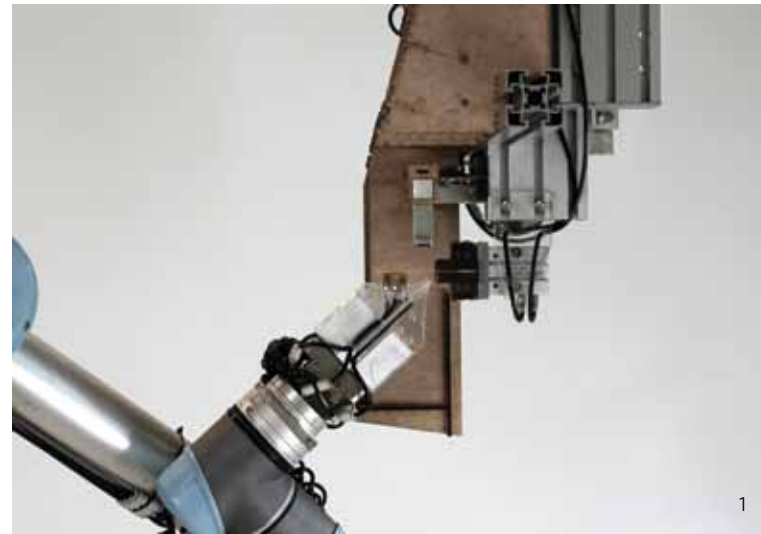

Robotic feeder and gripper system that allows picking and placing cardboard elements as well as transforming and assembling acrylic elements

Fabrication Process

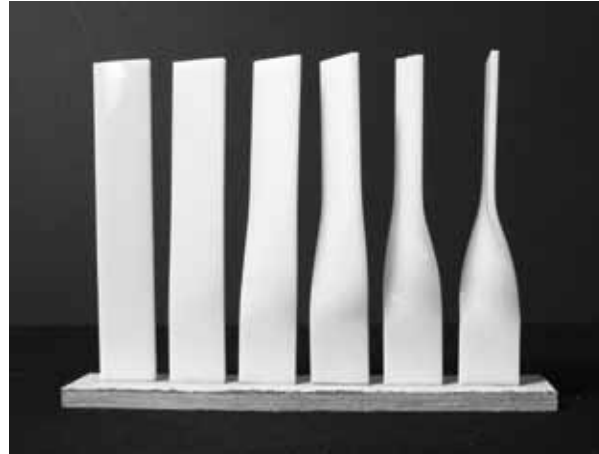

The deformed acrylic elements become the enclosing system and are placed in between the primary tectonic structure

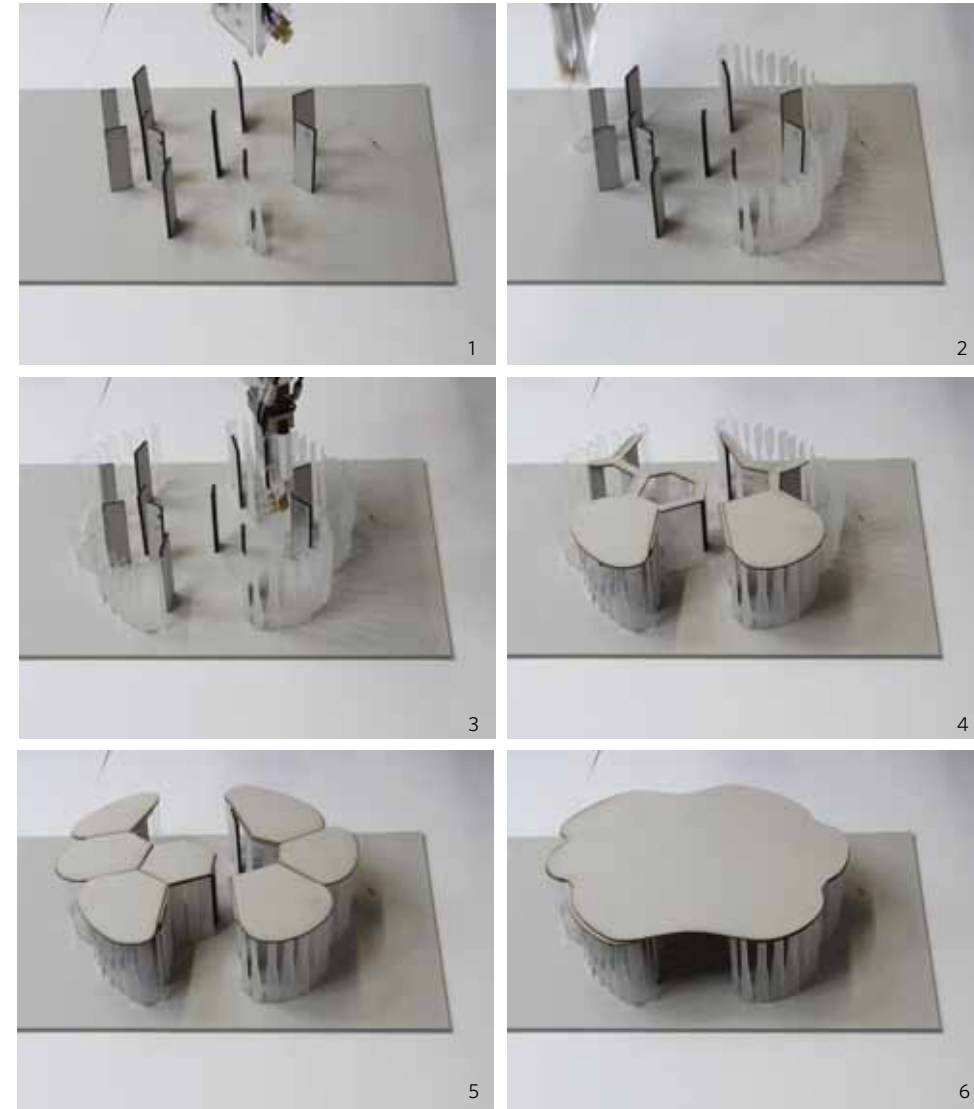

Sequence of the assembly process at a residential unit: primary tectonic structure (1), secondary structure (2, 3), beams (4), ceiling (5), floor plates (6)



Interior view

Fabrication Process





Undulating Terraces

Pearl Bank Tower

Students: Sebastian Ernst,
Silvan Strobach, Sven Rickhoff

This project is driven by an investigation into the robotic manipulation of sheet material, and the corresponding assembly processes of folded components into a geometrically complex high-rise structure. Going beyond the build-up of predefined discrete elements, the Undulating Terraces project takes advantage of the material properties of paper strips, which can assume differentiated curvilinear geometries if processed by a robotic arm. The design of the process, which consists of bending two paper strips by connecting them at different relative positions, demands for an accurate parameterisation of the material properties to allow a coherent and repeatable connection between the emerging curvilinear shapes and the corresponding digital model. Vertically clustering the resulting geometrically differentiated paper strips enables then to specifically react to varying structural demands: their dense layering at relevant structural intersections secures an overall stiff tower structure while the same system allows for the seamless emergence of architectural spaces where rarefied. Overall, this approach provides a smooth volumetric articulation and a continuous layering with gradual changes and adaptations.



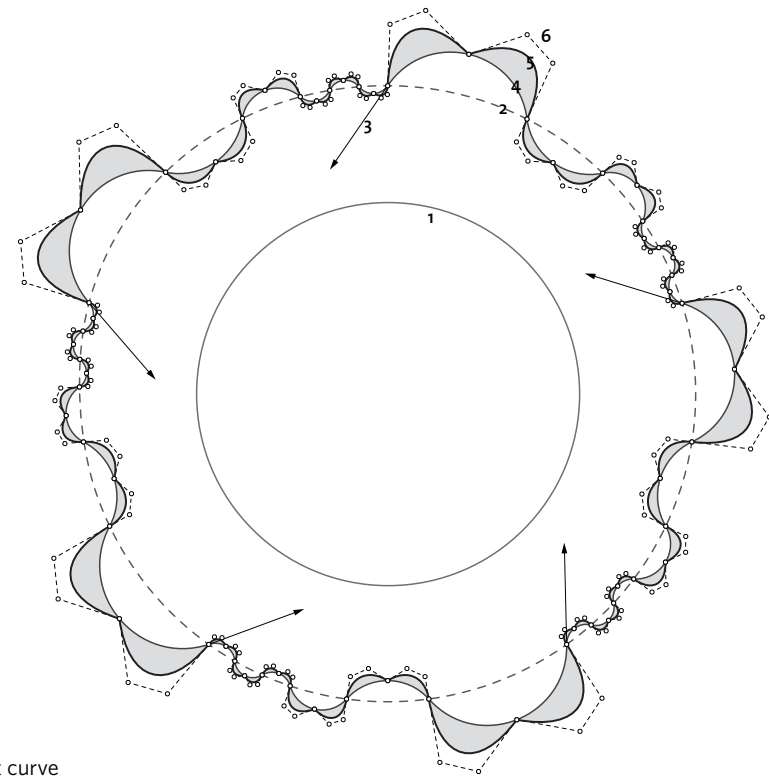

- 1: Input curve
- 2: Scaling of input curve
- 3: Subdivision of curve, generating tangent vectors
- 4: Creation of polyarc curve (strip 1)
- 5: Generation of nurbs cage
- 6: Creation of polyarc curve (strip2)

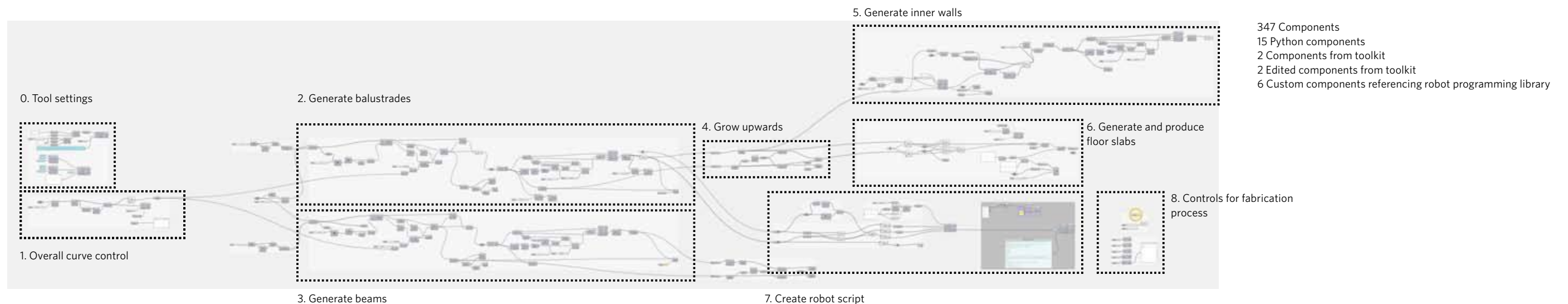
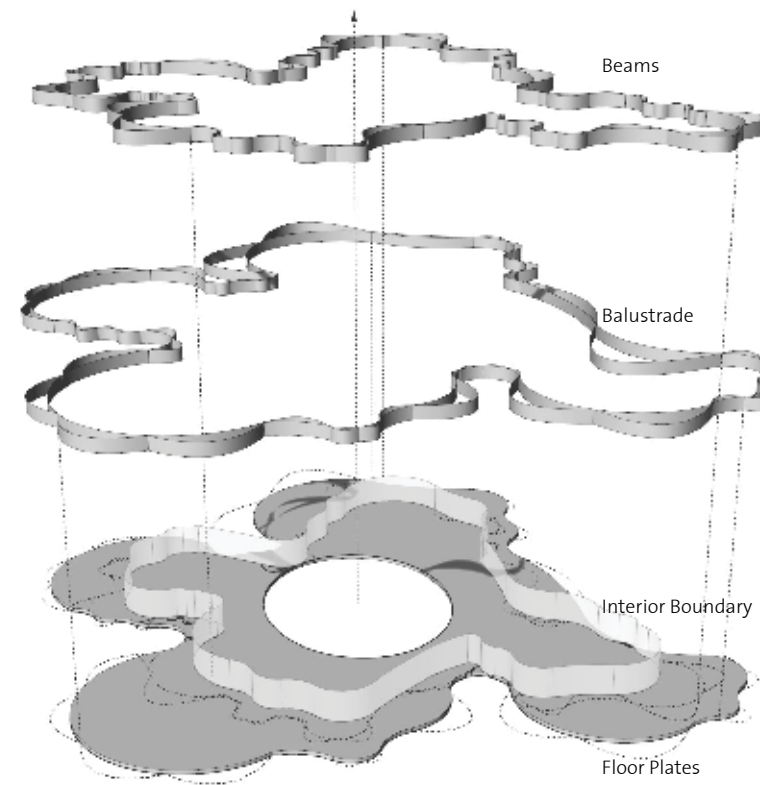

Design Concept

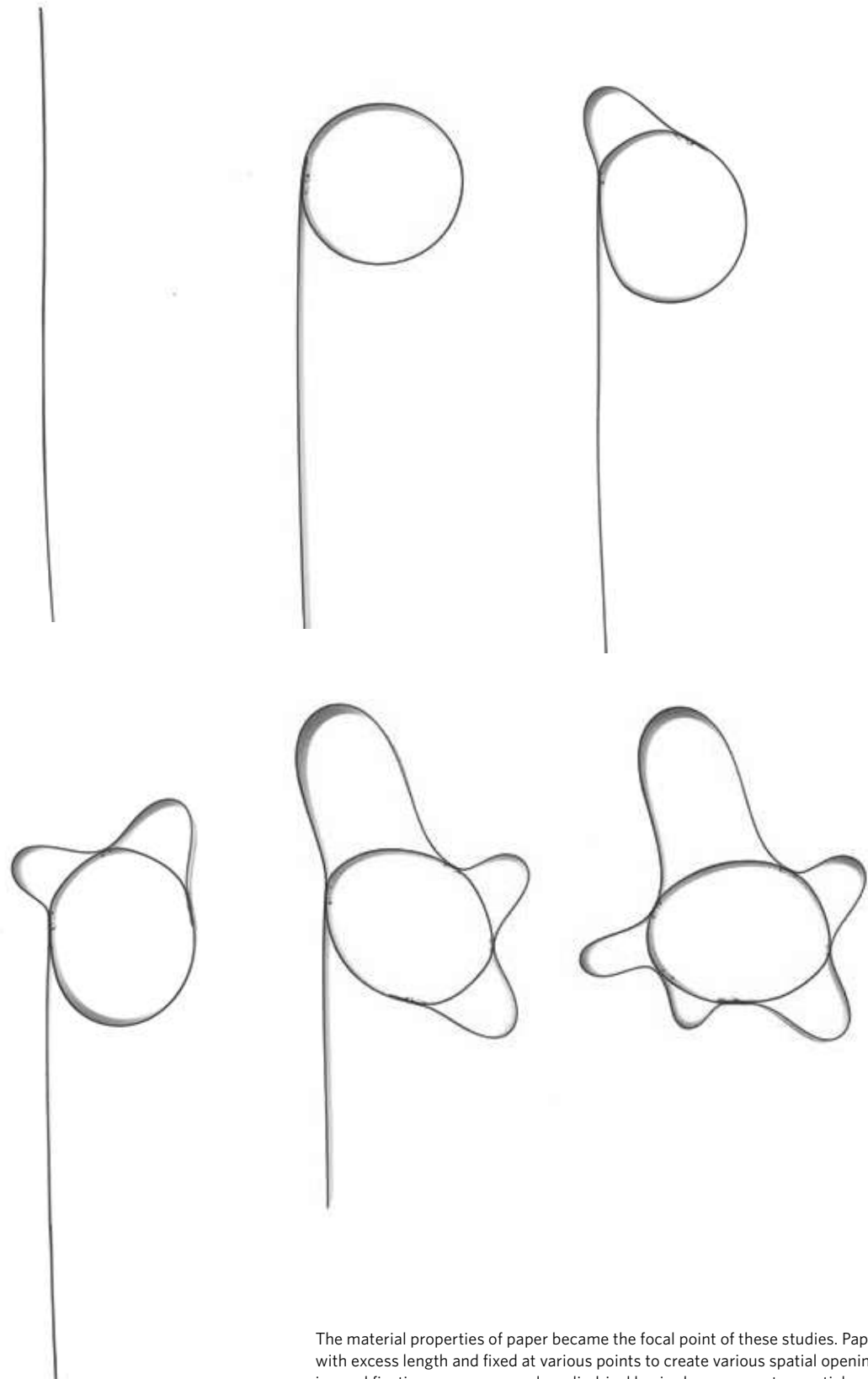

The material properties of paper became the focal point of these studies. Paper stripes are shifted with excess length and fixed at various points to create various spatial openings. A continuous bending and fixation process around a cylindrical basic shape generates spatial arrangements which are utilised as architectural spaces

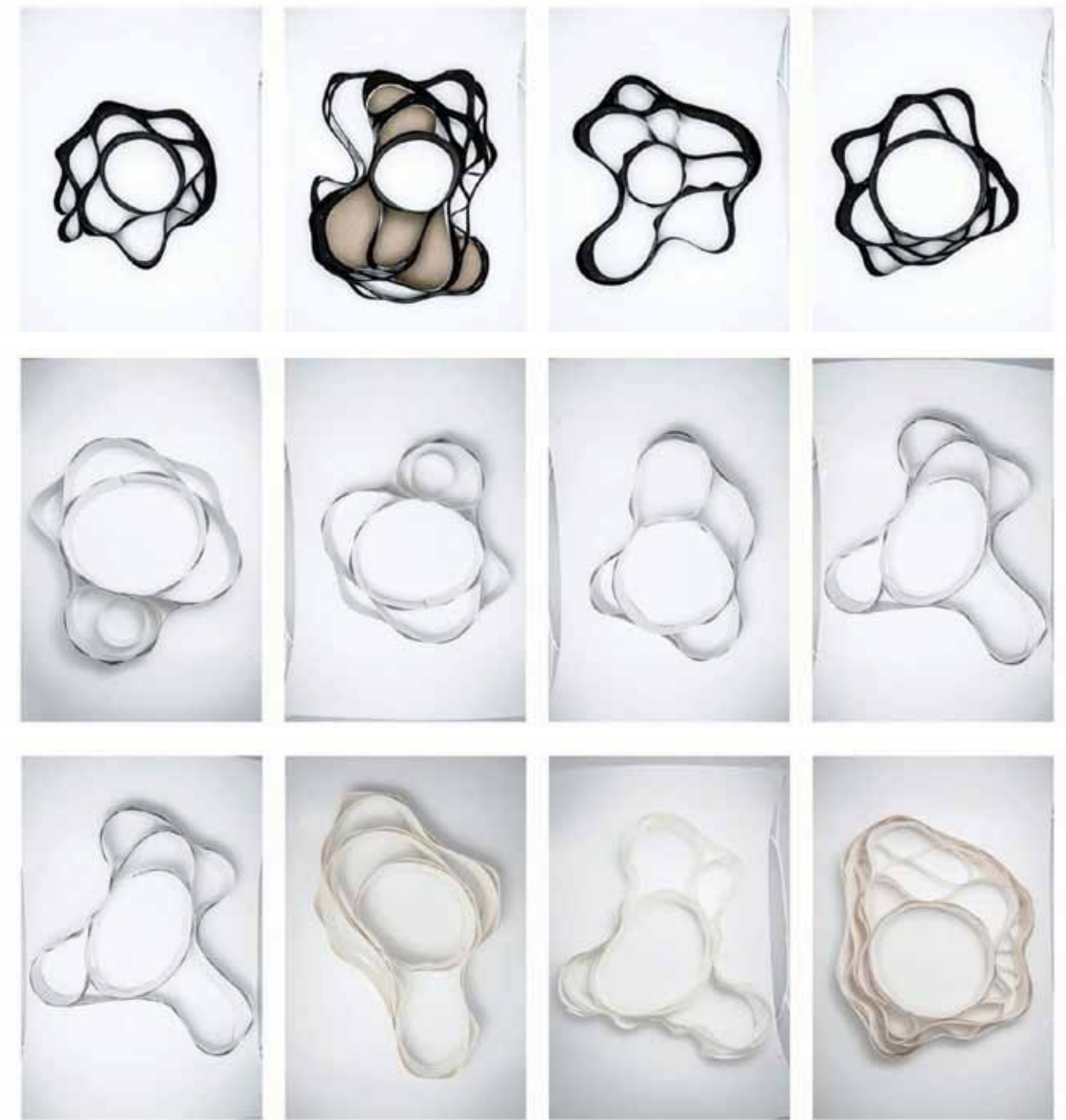

Evolution of various tests, where material starts to be layered and thus forms structurally and spatially differentiated assembly logics

Design Concept

Images on right page:

The material deformation strategy is utilised to create components that can serve as different building elements: floor to ceiling high elements form the load-bearing and enclosing systems, lower elements become part of balustrades or girder systems that support the floor plates above

1: Densification of the material

2: Creation of multiple layers resulting in zones with higher structural capacities

3: Expanding and delaminating the continuous stripes results in open volumes that take over the programmatic functions of inhabitable spaces

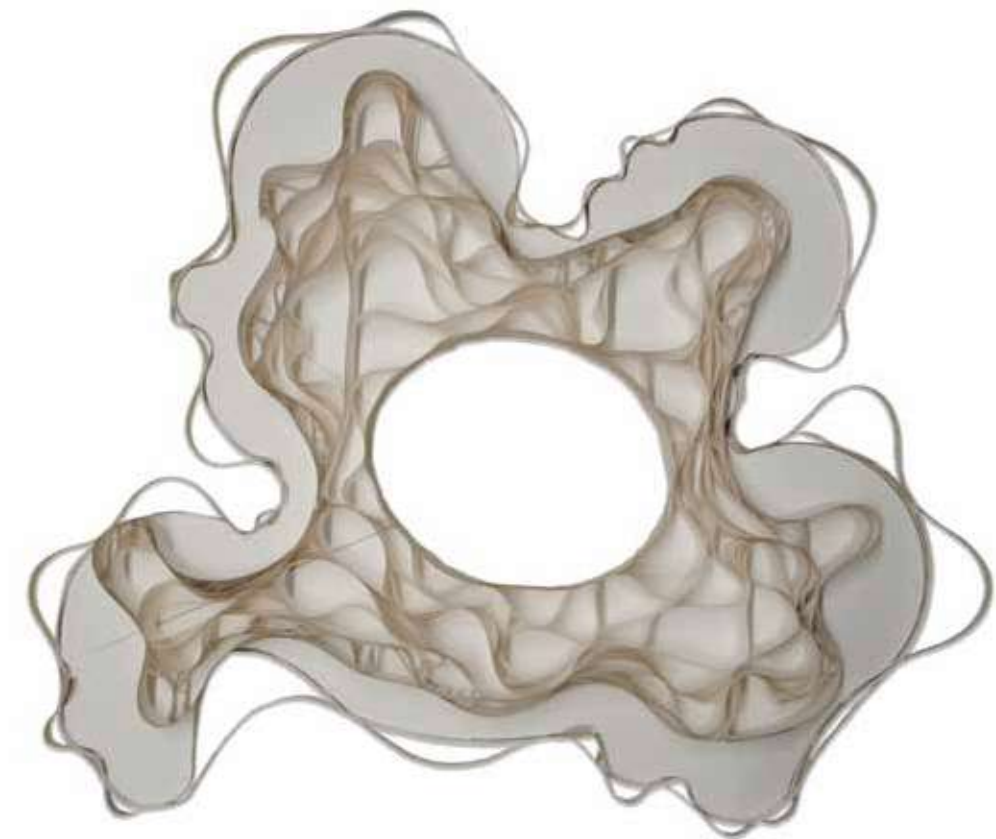
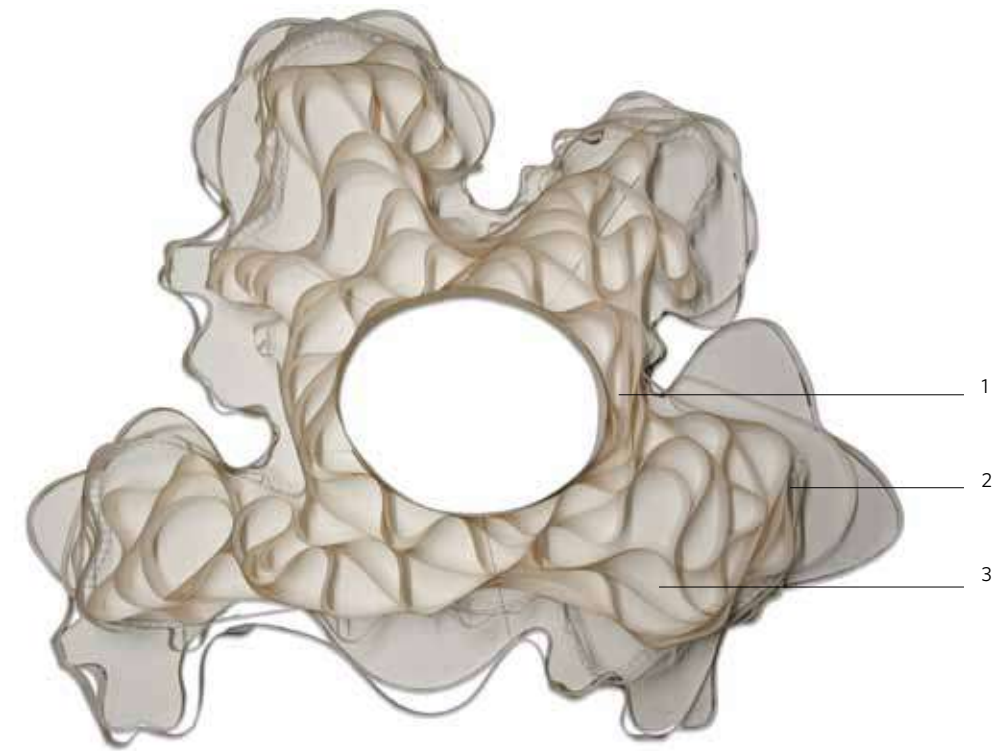
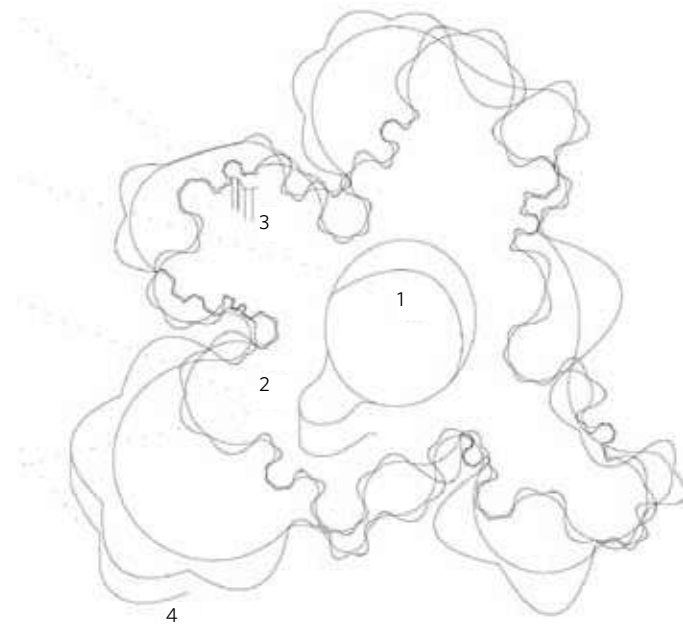

Floor plan configurations in the lower zones of the building with densification and expansion of the material layers

Design Concept

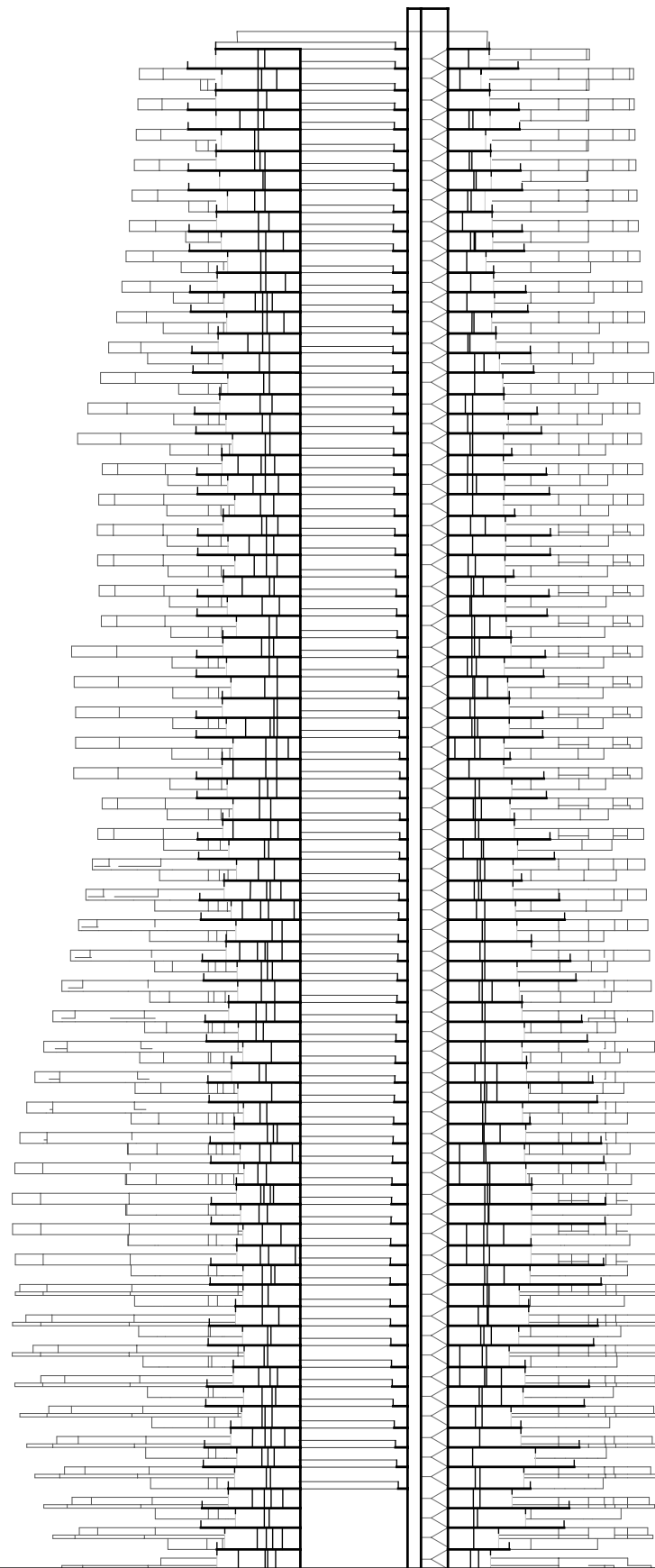

Section through the multiple layers, where the structural concept and the differentiated wall assembly become visible



Final tower model

Preliminary Tower Studies



Iterations of preliminary design studies

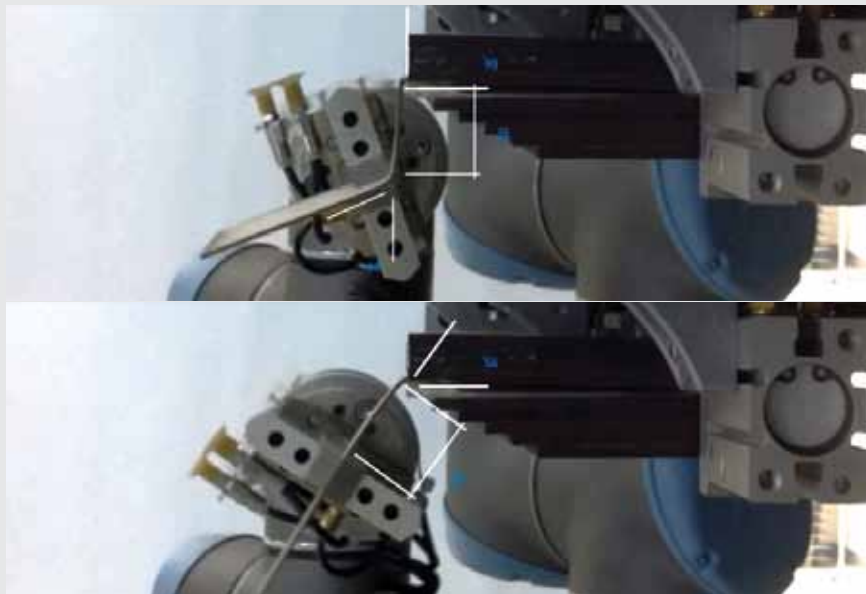

In the robotic fabrication process each wall element can be folded to unrestricted angles: the robot picks a flat sheet at the feeder, locks it in a clamping device and bends each sheet to predefined angles



First interim tower in 1:50 scale that is assembled from folded sheets as load bearing walls



Preliminary Tower Studies

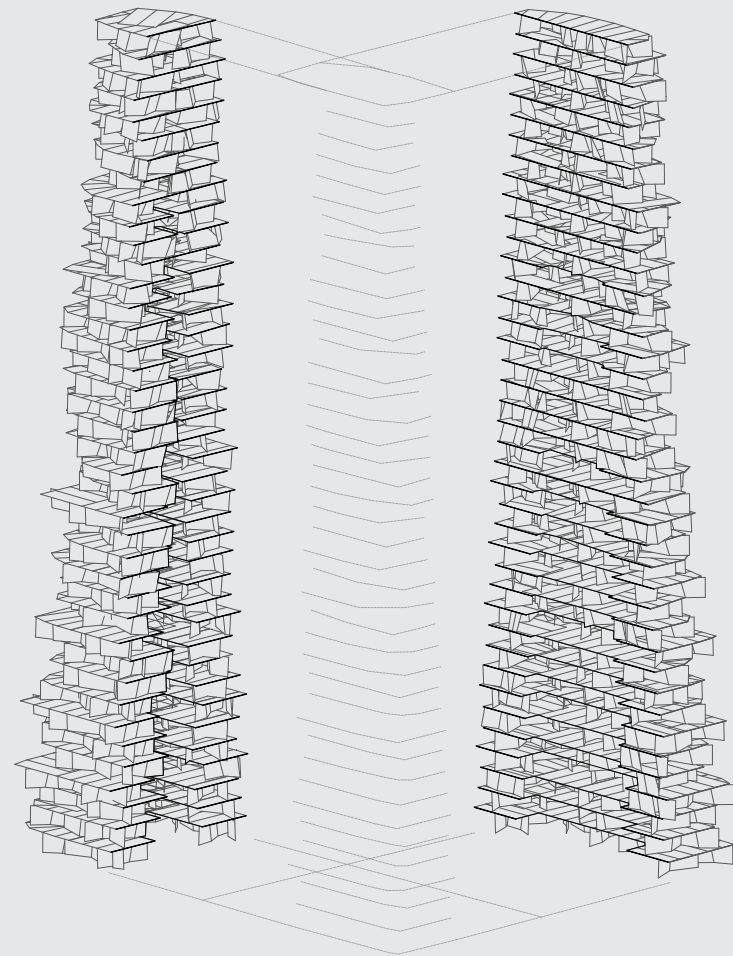

Sectional drawing of preliminary tower study with the circulation core on the inside

2.385 parts



Overview of the 2.385 initially identical parts of the last iteration of preliminary tower studies, which become individualised during the fabrication process by automated bending and folding



Preliminary tower before completion. The robot picks flat aluminium sheets, and folds them to specific angles before placing them

Tooling

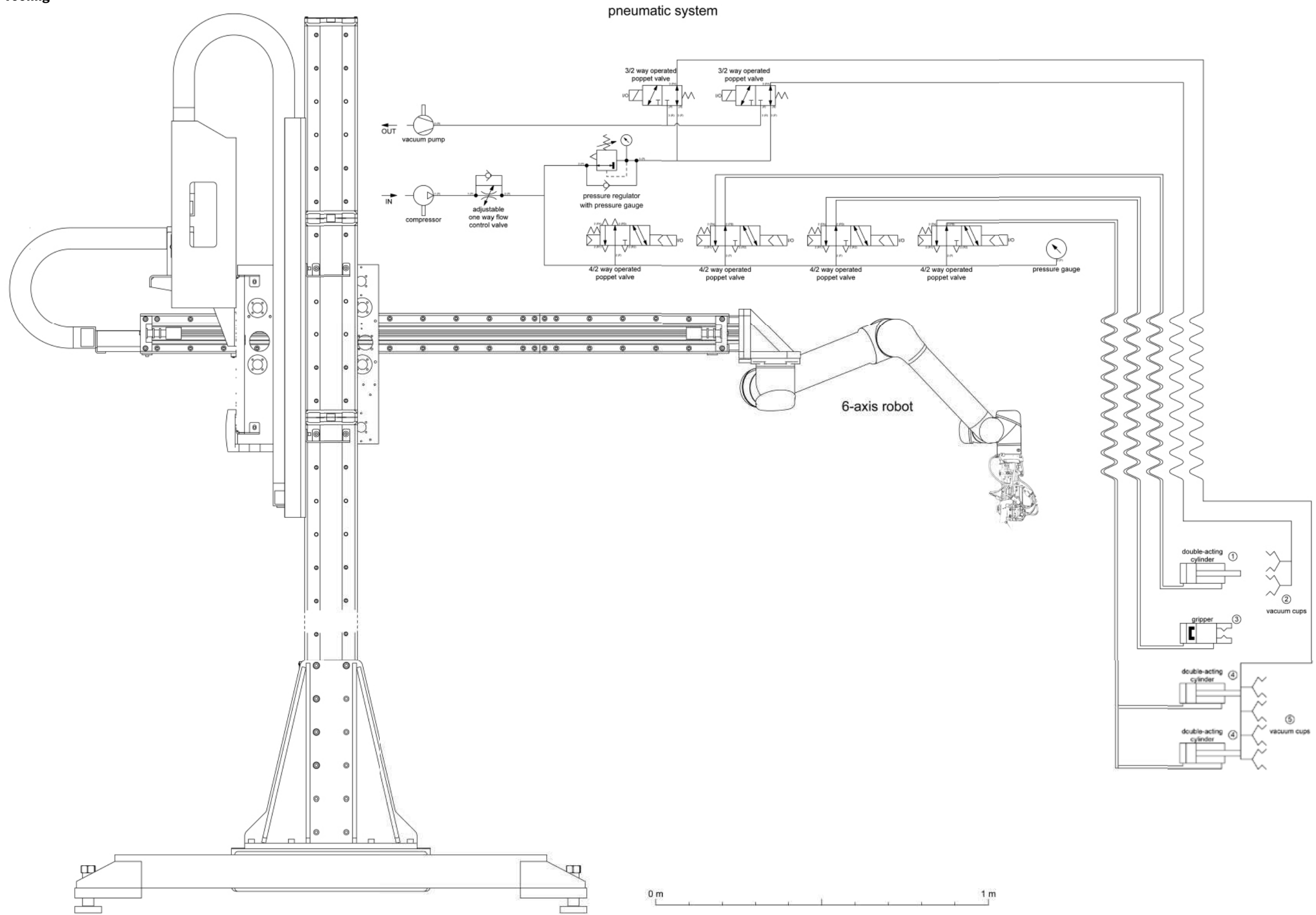

Fabrication Process

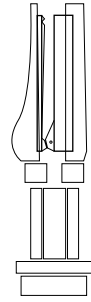

1

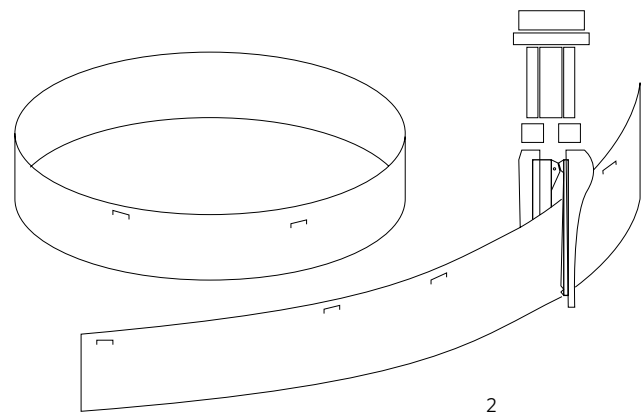

2

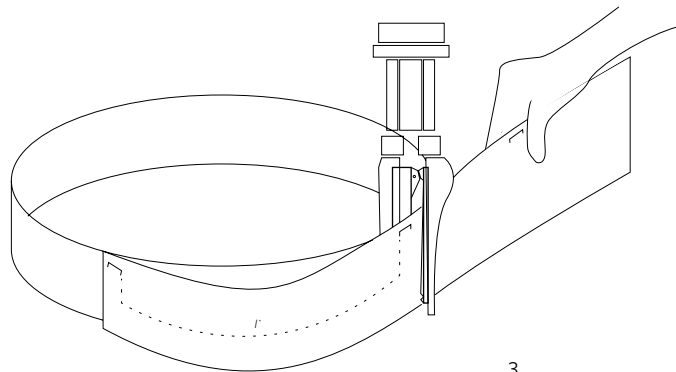

3

The initial focus of investigation was the material behaviour of thin paper sheets

1: The developed process involved the marking of thin strips at various distances

2: In a second step the strips would be fixated at the positions of these marks

3: Eventually the strips were pushed forward in different distances, thus producing curvilinear forms are, which can be controlled by reconfiguring the variables of steps 1 to 3

In the following phase, this process is simulated in a digital model. Different formal variations can be studied and eventually prepared for robotic fabrication (images on right page)

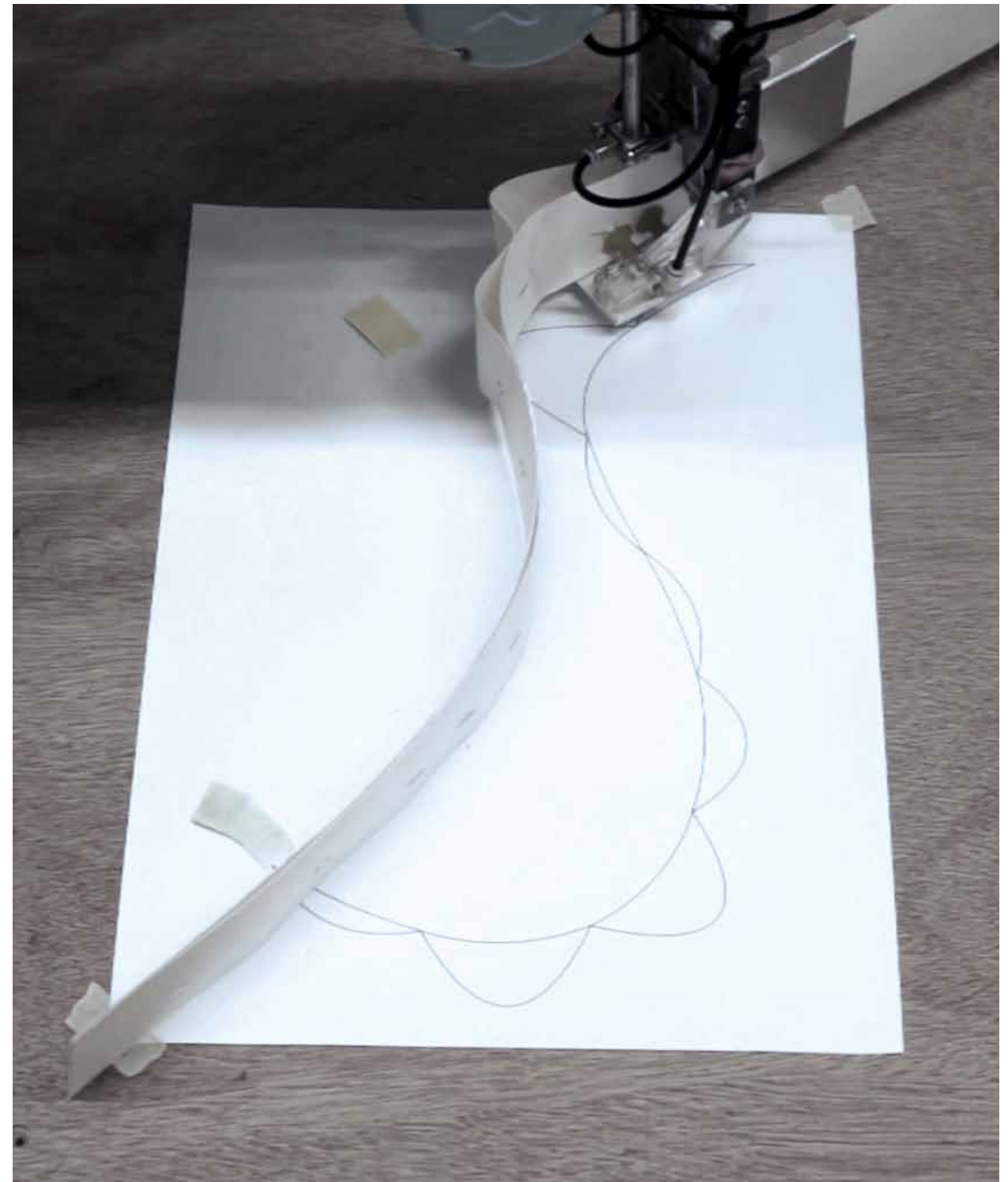

Further adjustments to match the virtual material simulation and the actual material behaviour

Fabrication Process

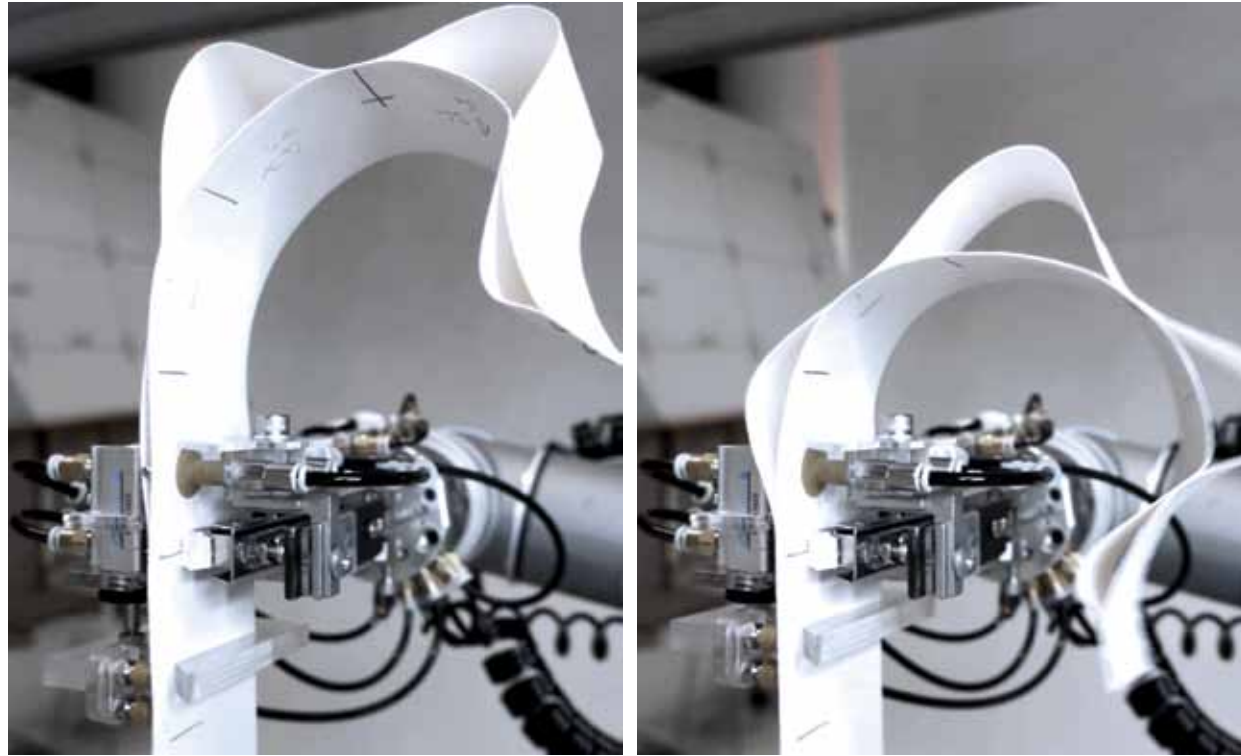

Material behaviour is tested by altering the distances between fixation points



Final gripper

The end-effector is specifically developed for this process in a large number of iterations, enabling the fabrication of stripes that were geometrically generated by a Grasshopper component. The process allowed the fabrication of large amounts of components in considerably low time

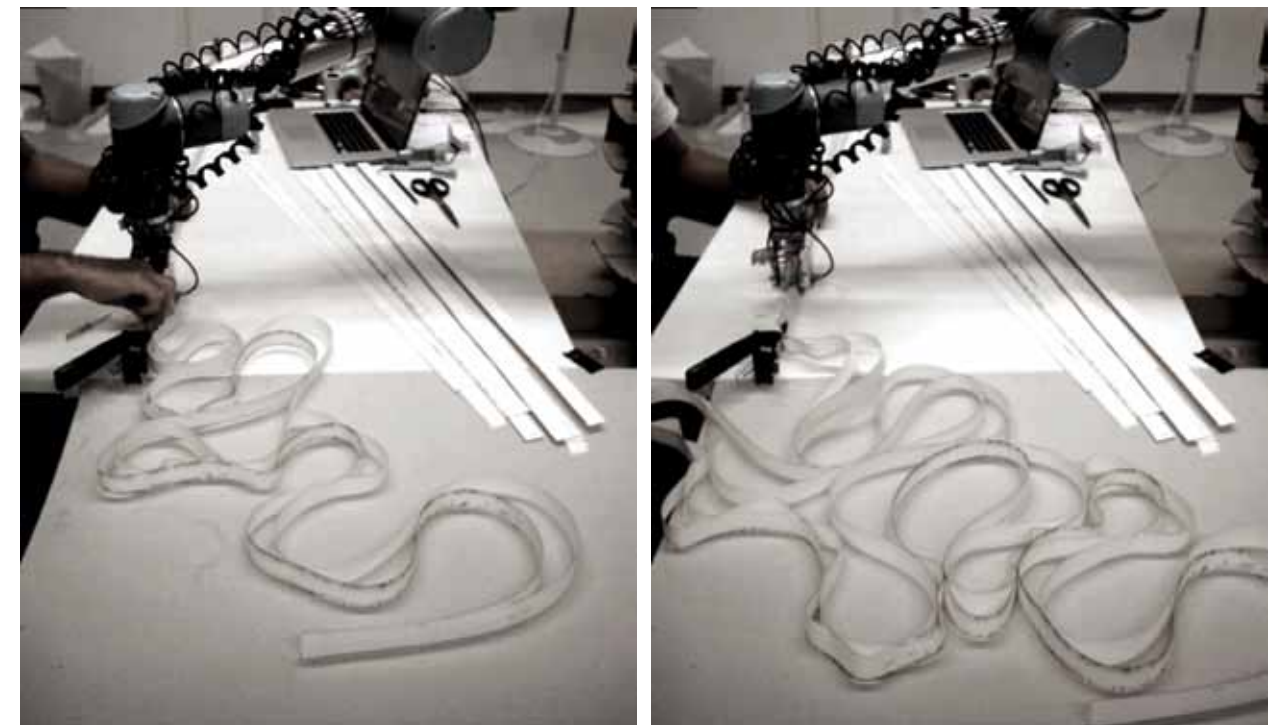
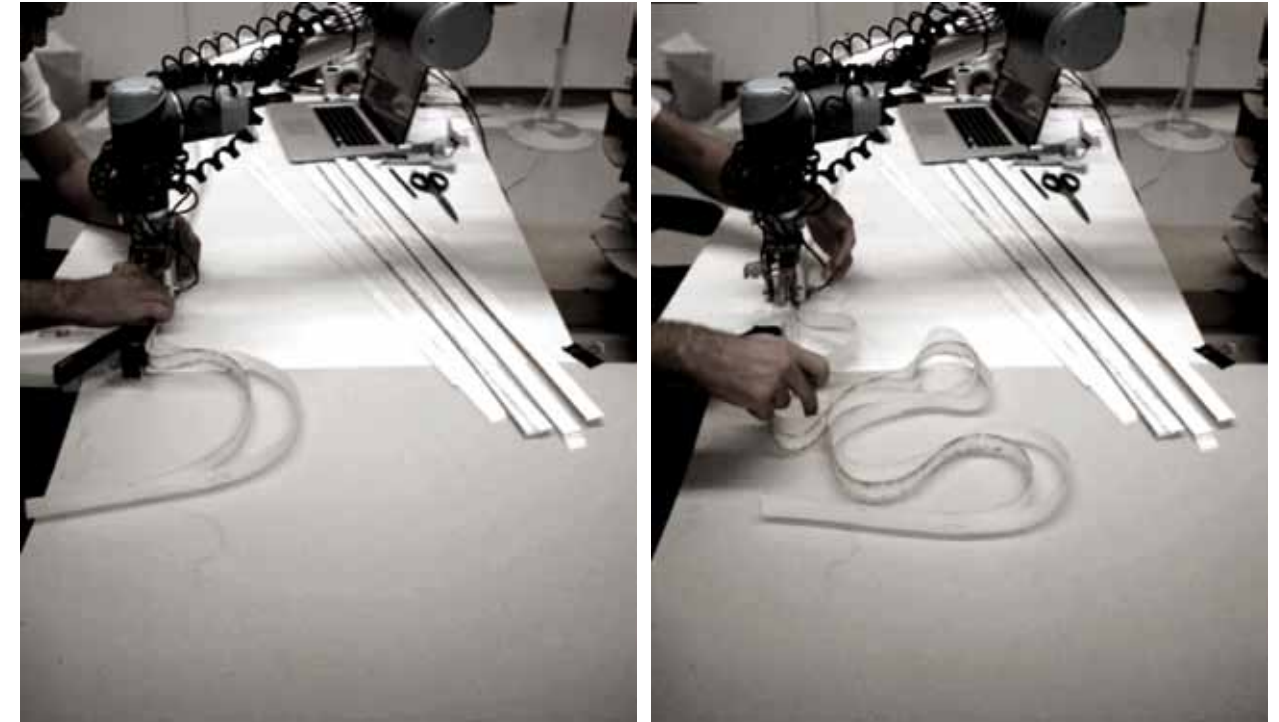

In the robotic fabrication process pre-programmed elements are produced that are layerwise assembled on the model

Fabrication Process

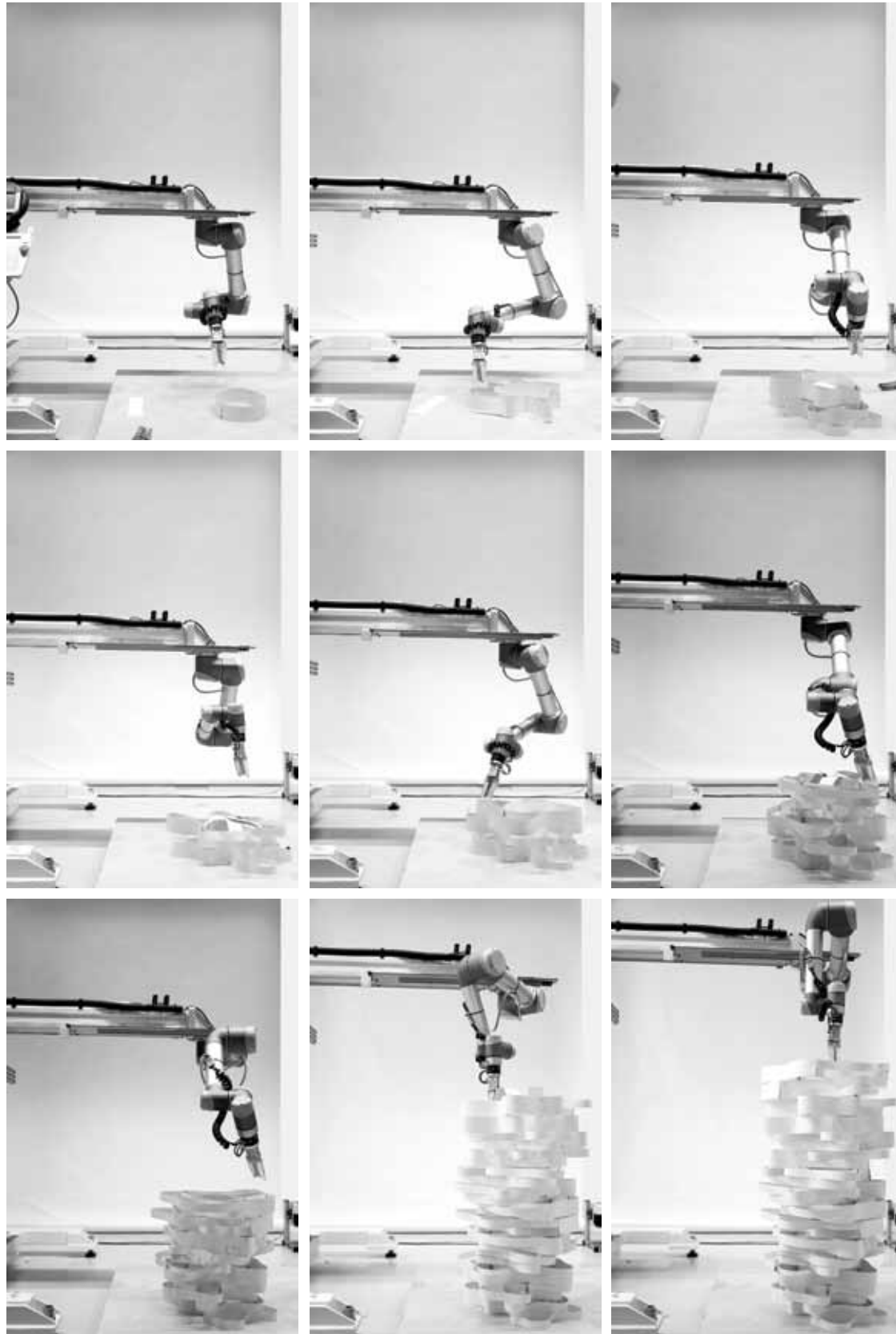



Shifting Volumes

Jurong Lakeside District

Student: Alvaro Valcarce

Shifting Volumes fosters a robotic construction system of radially assembled shear walls. A centralised component supply and manipulating system is placed at the core of the tower and enables the specific robotic positioning of the custom elements by simple rotation and linear translation. As such, the volumetric articulation of the high-rise follows a cylindrical shape with a central interior courtyard. This method results in shifting volumes protruding out from the main cylindrical volume and generating interconnected spaces with multiple double and triple height storeys.

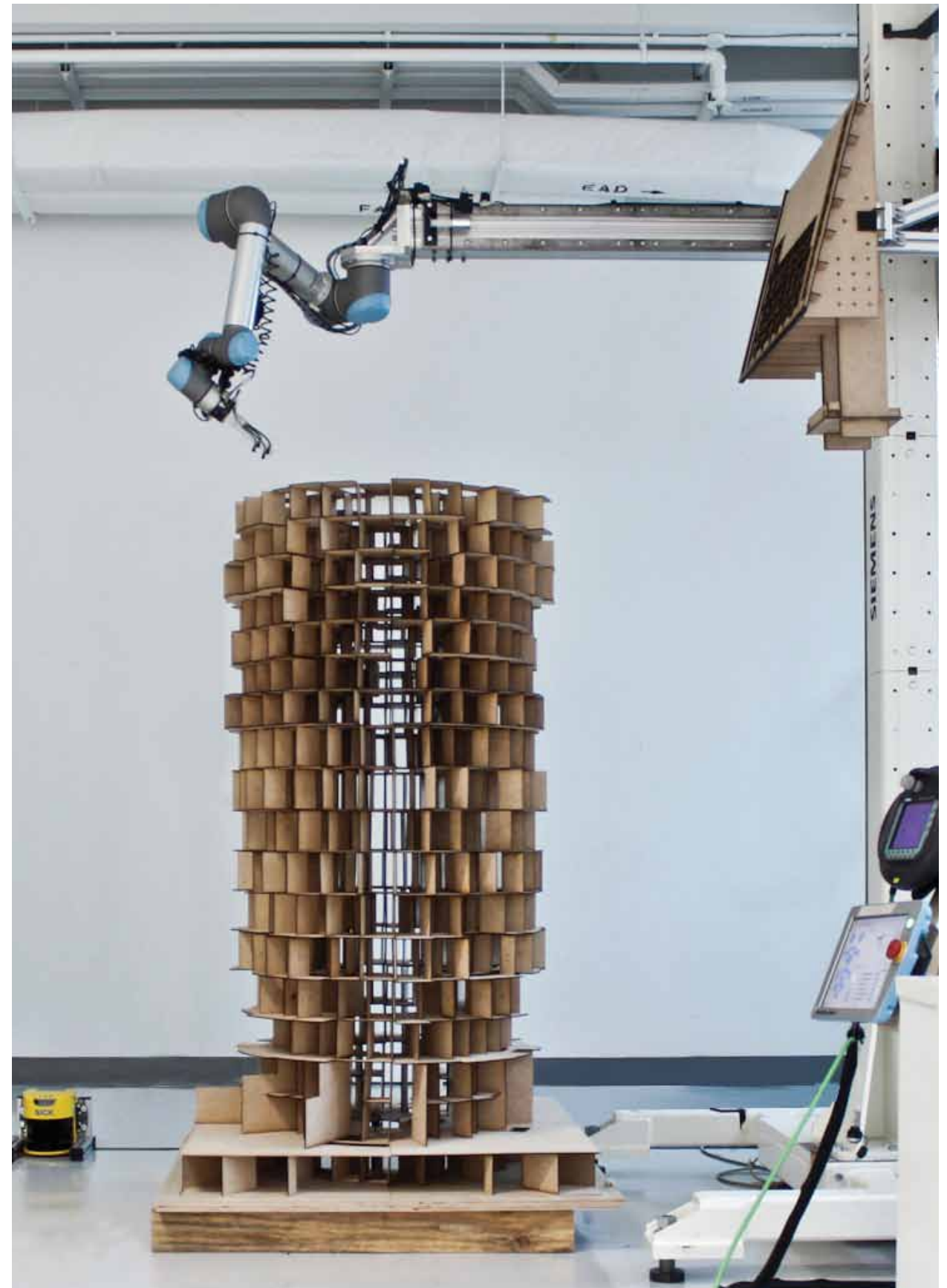

Computational Design

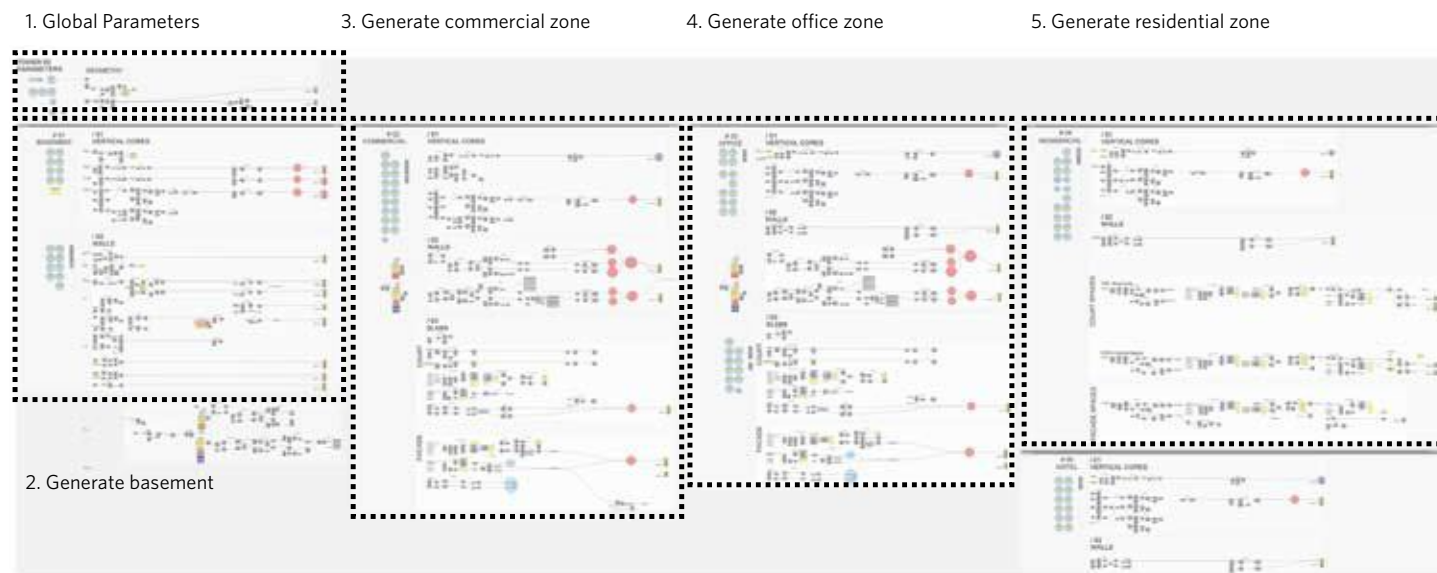
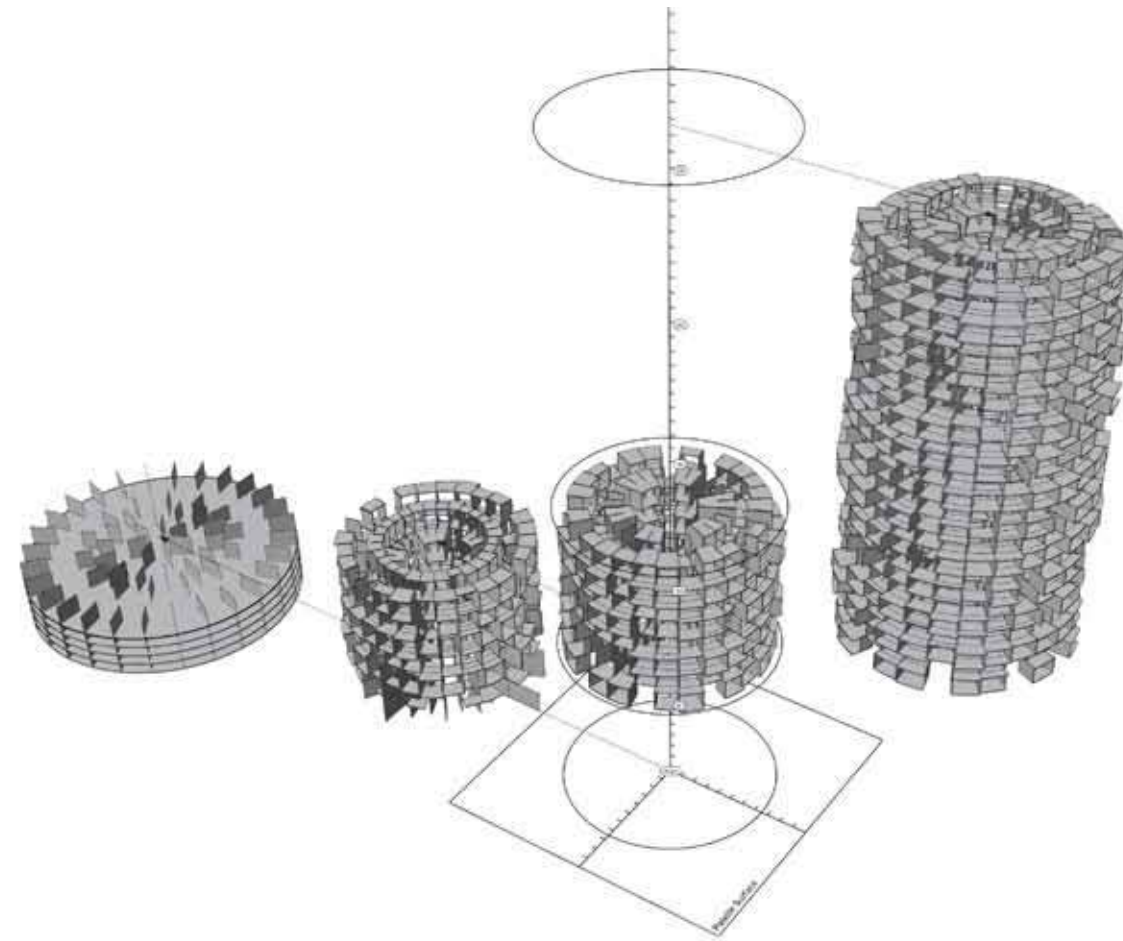
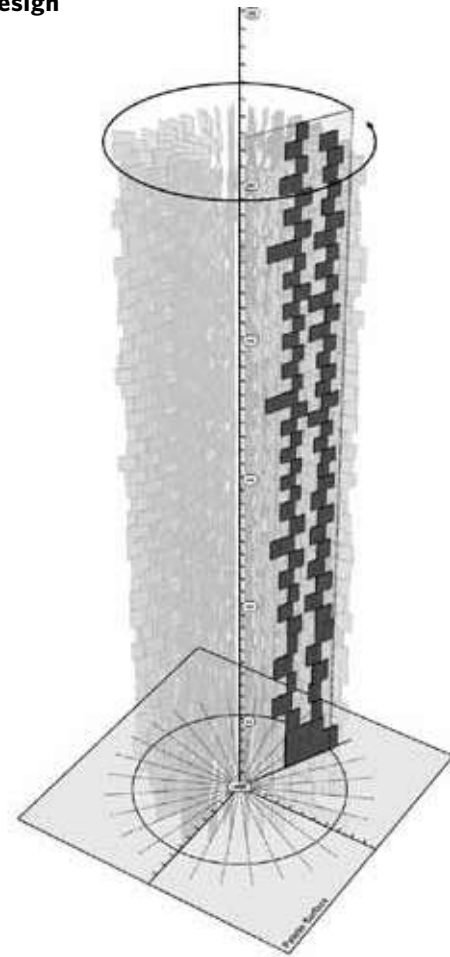

1911 Components
46 Python components

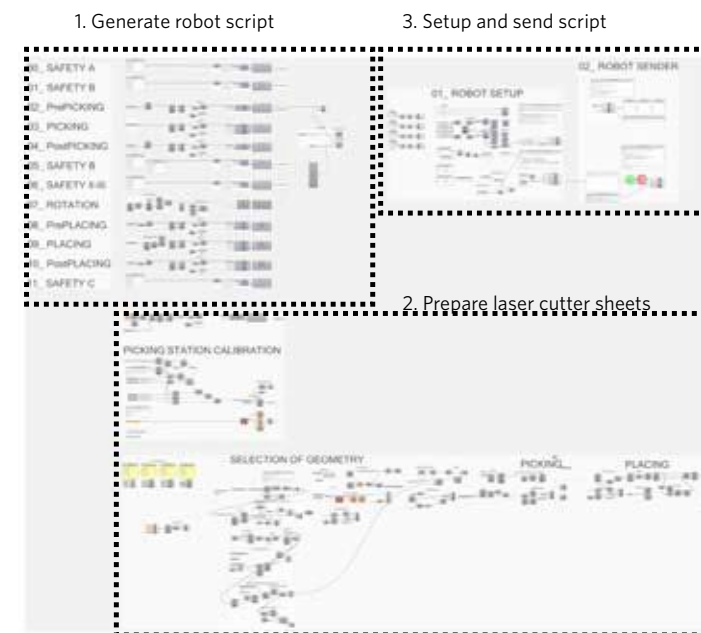

509 Components
22 Python components
17 Components from toolkit
1 Custom component referencing robot programming library

Design Concept

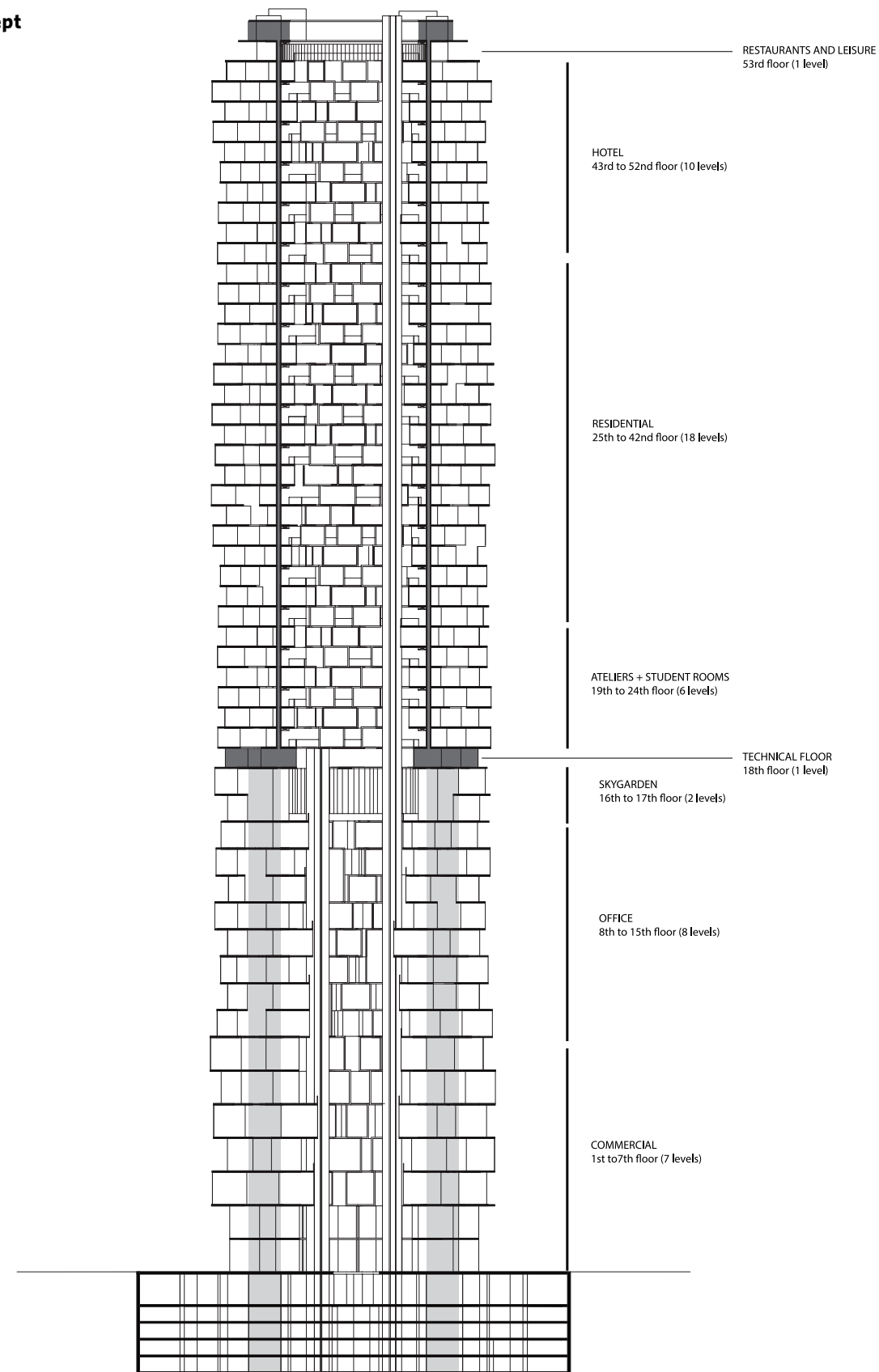

Section with the vertical distribution of functional zones



Final tower model

Fabrication Process

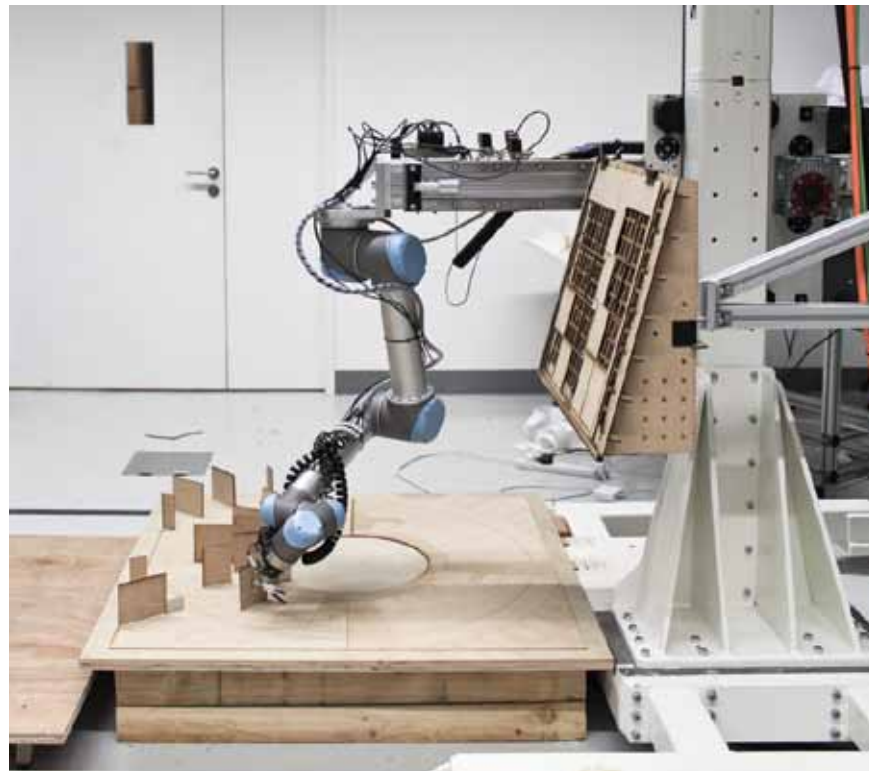
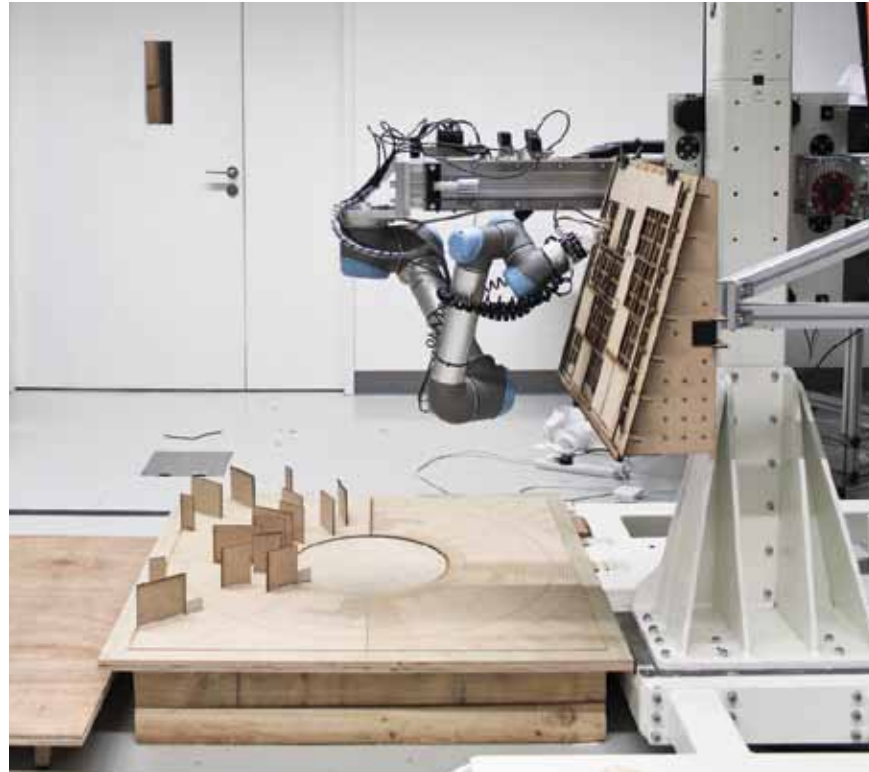

The grippers angles are optimised for picking and placing MDF sheet material

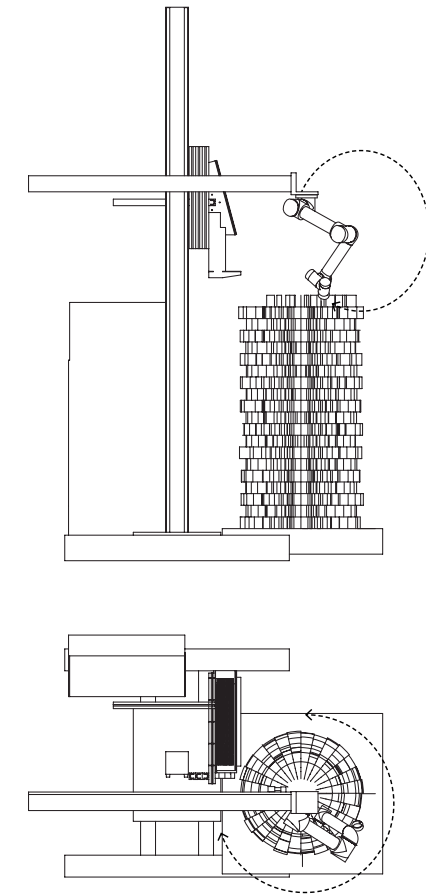

The robotic fabrication process simulates a radial assembly concept. Following this concept, the robot is taking position at a specific distance above the center point of each storey and slides the individual elements into their specified location











Colophon

Design of Robotic Fabricated High Rises No.01 Design Research Studio 2012

Publisher:

Research Module of
Architecture and Digital Fabrication
Future Cities Laboratory
ETH Singapore SEC Ltd

Editors:

Michael Budig
Raffael Petrovic

Layout:

Uta Bogenrieder

Graphical concept:

Lilia Rusterholtz and Uta Bogenrieder

Proofreading:

Text Control AG, Zürich

Print:

First Printers Pte Ltd, Singapore

Images:

Bas Princen: pages 6-7

Callaghan Walsh: cover, pages 8-9, 10-11, 12-13

15, 21, 22, 23, 24, 29, 37, 53, 54-55, 57, 65, 81, 82, 83, 85,
93, 107, 108, 109, 115, 118-119, 126-127

All other images © Gramazio & Kohler, Architecture
and Digital Fabrication, ETH Zürich 2012

Project funded by:

NATIONAL
RESEARCH
FOUNDATION

(SEC) SINGAPORE-ETH 新加坡-ETH
CENTRE 研究中心

Industry Partners:



GÜDEL

SIEMENS

© 2014 Future Cities Laboratory
ETH Singapore SEC Ltd
22B Duxton Hill
Singapore 089605

Research Module of
Architecture and Digital Fabrication
Gramazio & Kohler
Future Cities Laboratory
Singapore-ETH Centre
www.dfab.arch.ethz.ch
www.futurecities.ethz.ch

Prof. Fabio Gramazio
Prof. Matthias Kohler

Michael Budig (co-project lead)
Raffael Petrovic (co-project lead) s
Norman Hack
Dr. Silke Langenberg
Willi Lauer
Jason Lim

Students:

Pascal Genhart
Patrick Goldener (1st term)
Sylvius Kramer
Sven Rickhoff
Silvan Strohbach
Michael Stünzi
Martin Tessarz (1st term)
Florence Thonney(1st term)
Alvaro Valcarce
Fabienne Waldburger (1st term)
Tobias Wullschleger



ETH zürich

DARCH



CREATE