



Journal Issue

Robotic High Rises No.03: Research Projects 2011-14

Publication Date:

2014

Permanent Link:

<https://doi.org/10.3929/ethz-a-010709476> →

Rights / License:

[In Copyright - Non-Commercial Use Permitted](#) →

This page was generated automatically upon download from the [ETH Zurich Research Collection](#). For more information please consult the [Terms of use](#).



(FCL) FUTURE CITIES LABORATORY 未来城市实验室

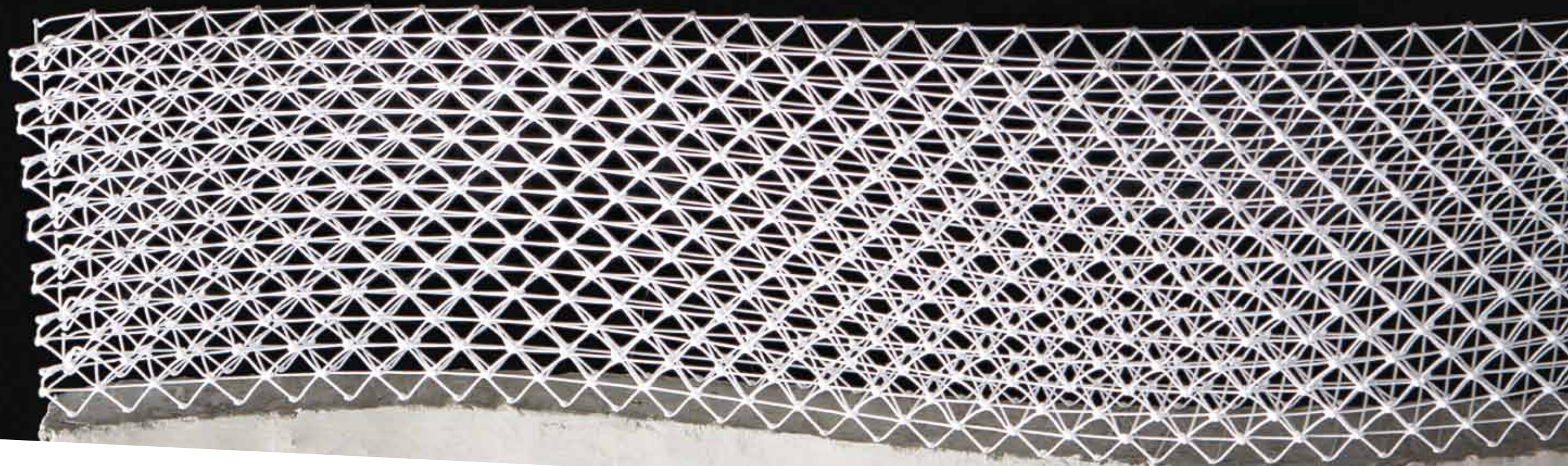

ETH zürich DARCH

(SEC) SINGAPORE-ETH CENTRE 新加坡-ETH 研究中心

(FCL) FUTURE CITIES LABORATORY 未来城市实验室

CREATE

Robotic High Rises No.03

FCL Magazine Special Issue

FCL MAGAZINE SPECIAL ISSUE Robotic High Rises No.03

Design of Robotic Fabricated High Rises | Research Module of Architecture and Digital Fabrication | Gramazio & Kohler | Future Cities Laboratory

Research Projects 2011-14

Foreword

The Future Cities Laboratory tackles the big challenges of urbanisation and environmental sustainability. We ask: What new knowledge of cities and city systems is required to properly manage the processes of urbanisation? What technologies and material resources will be required? And what skills and ways of working will be needed to support the sustainable development of future cities?

The architecture and digital fabrication team, led by Fabio Gramazio and Matthias Kohler, investigate a research theme that informs all of these questions: the systems and processes of production for future cities and, in particular, the interface between material and digital forms of production. The team investigate this theme in the context of the high-rise, high-density urban fabric of Singapore. It is clear that dense and tall cities offer a promising morphology for sustainable future cities more generally. Living collectively and at close quarters has been one of the ancient and defining features of urban life. The particular kind of high-rise urban living became possible with the development of new technologies in the nineteenth century – steel structural systems, mechanical lifts and air-conditioning primarily. Today, it is equally clear that the rapidly developing field of digital fabrication will play a defining role in developing sustainable high-density future cities.

Stephen Cairns

Editorial

Over the past decade, robotic fabrication in architecture has succeeded where early digital architecture failed: in the synthesis of the immaterial logic of computers and the material reality of architecture. With robots, it is now possible to radically enrich the physical nature of architecture, to ‘inform’ material processes and to amalgamate computational design and constructive realisation as a hallmark feature of architecture in the digital age. The employment of robotics in architecture is thus opening up the prospect of entirely new material capacities that could fundamentally alter architectural design and the building culture at large. The question is whether digital technologies can impact and therefore change ways of thinking about and materialising architecture.

The research work at the Future Cities Laboratory, Singapore-ETH Centre for Global Environmental Sustainability (SEC), is heavily anchored in this voyage of discovery and explores what happens if architecture absorbs the proposed connection – enabled by robots – between computational logic and material realisation as a new basis for the discipline’s practices and research culture. Here, the research on the design of robotic fabricated high-rises at the Future Cities Laboratory illustrates a pioneering attempt to place digital fabrication in relation to large-scale residential tower developments, and to explore the potential of robotic construction processes in an urban context. Within this scope, the design research studio is geared towards 1:50 models of mixed-use high-rises, which are computationally designed and robotically fabricated. Robotic fabrication thus overcomes the repetitive build-up of standard building elements in favour of a differentiated assembly of bespoke elements and links computational design to the fabrication of physical study models (see FCL Magazine Special Issues Robotic High Rises No.01 and No.02). Most importantly, the design research studio serves not only as a teaching platform but also as an experimental hub for in-depth research into the areas of computation, construction and fabrication. One example is the research on novel digital design processes and interfaces in order to make these technologies globally accessible (see Jason Lim’s work on learnable robotic programming).

On the other hand, these research projects at the Future Cities Laboratory are gradually expanding the range of robotic processes from prefabrication towards the direct use of robots on the construction site. Rather than a mere theoretical exercise, we regard such an empirical attitude as crucial to unlocking the full potential of robotic practices in architecture. This materialist approach proceeds from an understanding of design that is directly informed by the material’s inherent constructive capacities in conjunction with well-attuned fabrication principles (see Norman Hack’s and Willi Lauer’s research on mesh mould structures). Rather than merely ‘illustrate’ a predetermined design idea, architectural design should be informed by novel fabrication processes directly derived from the logic of the given material system.

In turn, academic research in this area is giving rise to concrete building applications and innovative business ideas. And comparable to the 3D-printing sector their dynamism is increasingly taking hold and permeating the entire field of architectural activity to the hum of ‘how to make almost anything’ (Neil Gershenfeld). Should robotic fabrication processes such as our robotic tiling project actually become commonplace in the construction industry over the next few years these practice-based and application-oriented research projects could be credited with having dauntlessly transformed the building industry bottom-up and facilitated the breakthrough of the architectural production at large (see Tobias Bonwetsch’s and Selen Ercan’s contribution on robotic tiling).

As our research projects show, the robotic fabrication of tomorrow will no longer be bound by constricting standards, constraints or ideologies, but will allow radically new perspectives of material-driven research and architectural experimentation. It is precisely this seminal shift which is unleashing a previously unimaginable range of freedom in the exploration of the interplay between digital and material processes. In other words, architecture is at long last beginning to develop an adequate research culture for the (materialist) logic of the ‘second digital age’.

Fabio Gramazio, Matthias Kohler, Jan Willmann and Michael Budig

CONTENT

Credits:

The editorial text is an excerpt of the introduction article that was originally published in: Gramazio, F and Kohler, M (eds) (2014) Made by Robots: Challenging Architecture at a Larger Scale, Architectural Design No 229, London: Wiley & Sons. p. 14-21.

Acknowledgements:

The Research Module of Architecture and Digital Fabrication would like to express their gratitude to the current and former directors of the Singapore-ETH Centre and the Future Cities Laboratory. Special thanks go to the management team for their continuous and tremendous support. Last but not least we would like to thank the wider Future Cities Laboratory community for making the past years such a stimulating and memorable time.

2	FOREWORD <i>Stephen Cairns</i>
3	EDITORIAL <i>Fabio Gramazio, Matthias Kobler, Jan Willmann, Michael Budig</i>
14	YOUR <i>Jason Lim</i>
30	MESH MOULD <i>Norman Hack, Willi Lauer</i>
56	ON-SITE ROBOTIC TILING <i>Tobias Bonwetsch, Selen Ercan</i>
76	ADDENDUM
88	COLOPHON



Future Cities Laboratory / Research Module of Architecture and Digital Fabrication

Robotic and automated productions have taken over large parts of many industrial sectors. Although highly ambitious and sophisticated, most attempts at using robotic processes in architecture remain exceptions, prototypes or even failures at a larger scale, because the general approach is either to automate existing manual processes or to automate the complete construction process. However, the potential of robotic fabrication is not fully exploited if used for the execution of purely repetitive mass fabrication processes. Robots can be controlled individually and thus offer the potential for variety and differentiated assembly – even at large scale. The challenges of diverse construction systems and changing demands for each

project need to be taken into account, without limiting the range of design. Existing methods and processes have yet to be negotiated in this context. It is time to think about customised robotic processes, products and planning methods for architecture at large scale. At the SEC Future Cities Laboratory, our Chair of Architecture and Digital Fabrication has built up a laboratory to research the potential of robotic processes in architecture and to develop concrete scenarios for their large-scale application to the design and construction of novel high-rise typologies.

Fabio Gramazio and Matthias Kohler

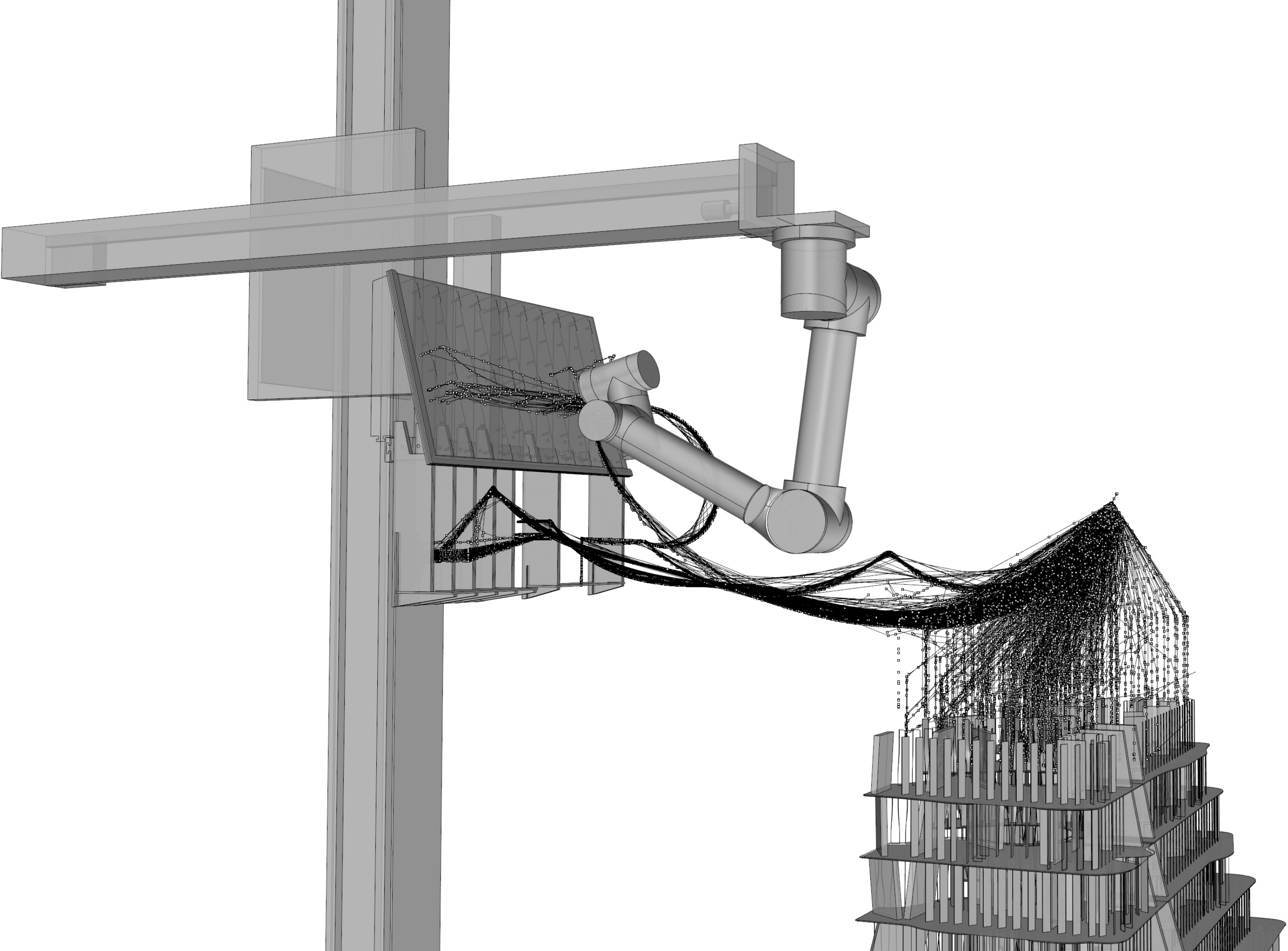

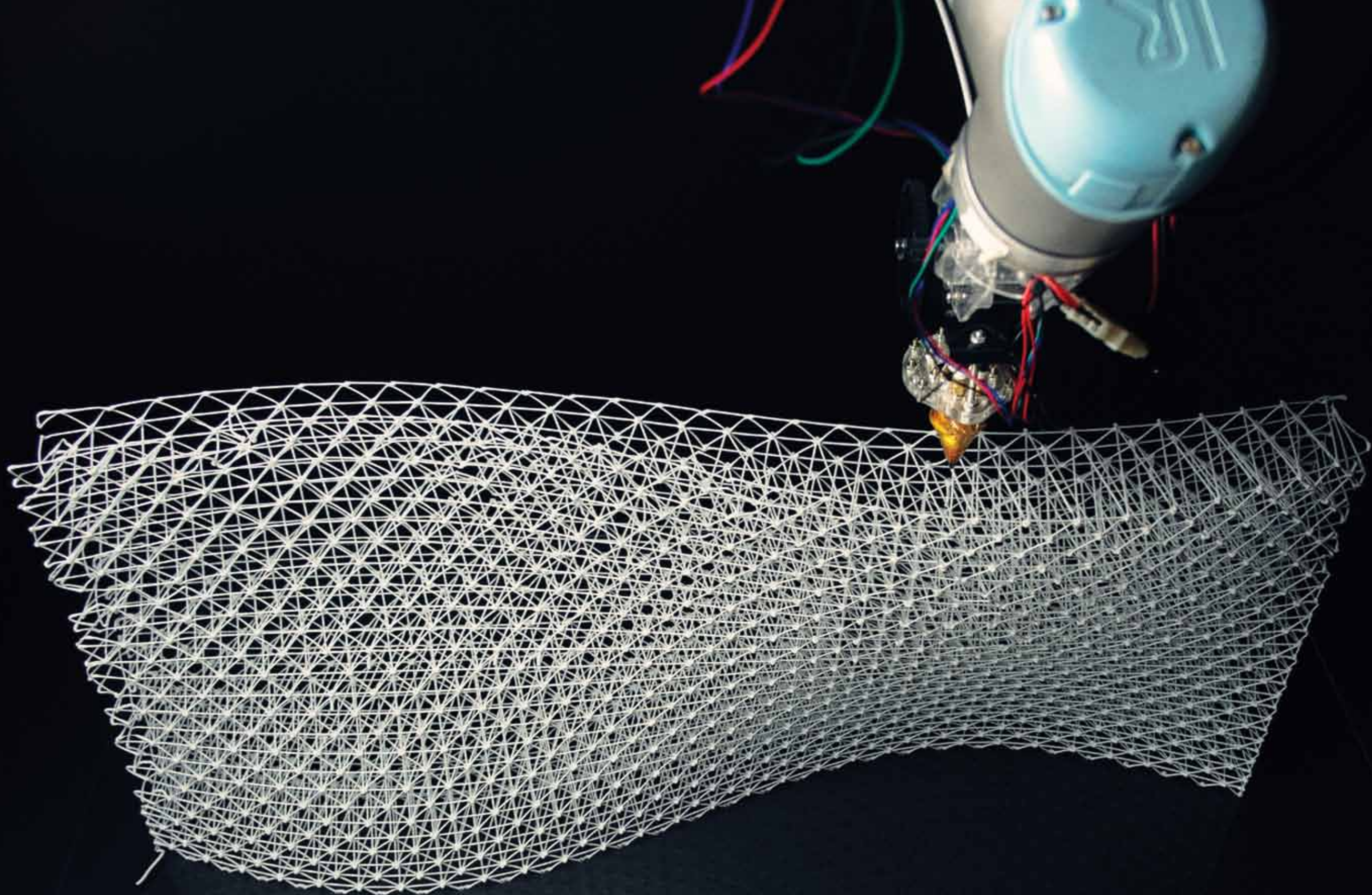



YOUR

Towards learnable robot programming

Jason Lim

Two decades ago, the availability of affordable computers prompted a digital turn in architecture (Carpo, 2011). Today, the increased accessibility of a different programmable machine promises to have a similar impact. Robot arms, once restricted to industry, are now increasingly used in the architectural domain for fabrication purposes. As more architects engage in physical production through robotics, a new design sensibility has taken root; decisions are no longer driven by digital logics alone, but are now informed in equal measure by tectonic and material considerations (Willmann et al., 2012). A robotic arm offers multiple advantages when applied to fabrication. It has an articulated morphology that makes it highly agile. Thus it can add, subtract or form material in ways that fabrication machines with fewer mechanical degrees of freedom cannot. In place of a hand, it has an end-effector, which is interchangeable. The potential to add new end-effectors vastly expands the range of robotic processes that can be implemented. When equipped with sensors, a robot can react to material behaviour. As a consequence, robotic fabrication has freed architects to design more geometrically complex forms, develop bespoke fabrication techniques and work with unconventional material systems. Physical artefacts, which were once impractical or impossible to produce using standard methods, are now realisable via robotic means. Programming is the key to unlocking the robot's full potential.

Authoring robotic processes

The robot's versatility is the key reason why it has been successfully appropriated for use in architecture. However, it also causes the robot to be a difficult machine to control. Standard fabrication machines, such as Computer Numeric Controlled (CNC) mills and laser-cutters, are designed to carry out specific processes. These processes are well defined since their constraints and parameters are known in advance. Consequently, Computer-Aided Manufacturing (CAM) software can be developed that automatically generates control code, thus freeing users from having to provide instructions themselves. In comparison, the robot is designed to be a general-purpose machine. A CAM solution cannot be developed that will be able to generate control code for all possible robotic processes since they are potentially unlimited (Bonwetsch, 2012). Hence, users are responsible for authoring low-level instructions.

Programming is the process of instructing the robot. These instructions have to be specified in a notation that the machine understands. By default, this takes the form of text programming languages provided by robot manufacturers (Fig. 01). Here, the end-user controls the robot by manipulating an abstract notation, rather than by physically guiding it or using a handheld teach pendant. As a result, programming introduces a 'level of indirection' (Aish, 2005) that separates end-user from machine, thus making the process of control less intuitive.

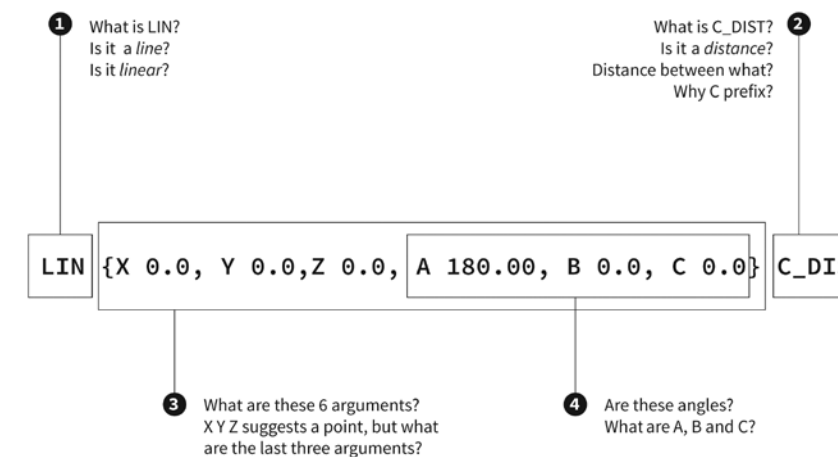

Fig. 01 An example of a typical movement command in the programming language for controlling KUKA industrial robots

Two forms of knowledge are essential for robot programming. The first is declarative in nature – it concerns ‘what is’ questions. To use any language, end-user programmers must first learn what the rules are for assembling primitives, and what the resultant constructs will mean. The further a programming language’s syntax and semantics differ from natural languages, the greater the challenge of expressing intentions in it. At the same time, they must acquire domain-specific knowledge. An understanding of kinematics and physical computing concepts is necessary in order to plan robotic motions and to interface with end-effectors and sensors. The second type of knowledge is imperative in nature and addresses ‘how to’ issues. It involves learning strategies to design, generate and evaluate programs (Robins et al., 2003). Such applied knowledge is mainly acquired through practice, hence the acknowledgement that novice programmers require a considerable number of years to gain expertise (Winslow, 1996).

For architect end-users, robot programming takes place concurrently with other activities, including design and physical tooling for the robot. Each activity constrains the others. For example, simply changing the length of an end-effector may have cascading effects. The control instructions have to be altered in order to plan a new collision-free motion path. The robot may not be able to reach all previous positions as a result. Thus the underlying design has to be adjusted and this could set off a new chain of modifications. When the designs, fabrication processes and end-effectors increase in sophistication, these interrelations may become intractable unless strategies are devised to address them. While each activity is manageable on its own, a steep challenge lies in synthesising all three.

It is evident that robot programming is difficult. It requires a breadth and depth of knowledge that is difficult to fully acquire. Such knowledge must be strategically deployed when robotic fabrication is part of a larger design endeavour. Recent developments in integrating robot-programming functionalities into CAD applications aim to reduce such difficulty. These approaches show that robot programming by architects is feasible and a promising field of research. However, such systems have not been empirically evaluated and a gap exists in research studying architects’ robot-programming activities.

Uncovering the architectural potentials of robot-programming

As a result of this research gap, the process by which architects learn and perform robot-programming is poorly understood. Consequently, it is unclear what kind of programming system is appropriate for them and in turn, to what extent such a system will affect the ‘intellectual act of design and the material act of building’ (Carpo, 2013).

Yet the current trend is to develop robot-programming systems that utilise visual notations². Such notations use graphics rather than text to encode meaning (Nardi, 1993). The directed graph is a prime example. Boxes representing data or operations make up the nodes of the graph, while wires connecting boxes make up its edges. The way data flows through the graph determines the program’s output. Visual programming is commonly assumed to be more accessible than text-based systems and this underlies their popularity. Burnett et al. offer several key reasons: less pre-existing conceptual knowledge is needed, the programming process is more concrete, relationships are explicitly represented and there is immediate feedback (Burnett et al., 1995).

The commercial success of design software based on a visual dataflow paradigm appears to lend credence to this view. After all, their key selling point is that end-users can begin generative design without having prior programming knowledge. However, empirical research disputes the superlativist claim that visual notations are inherently better than textual ones (Green, Petre and Bellamy, 1991). Instead, it is suggested that any notation’s effectiveness depends on how well its cognitive dimensions (Green, 1989; Green and Petre, 1996) fit the profile of the supported activity (Blackwell and Green, 2003). In other words, the same notation may be better for one task and worse for another.

This research addresses the questions: What are the architectural potentials and benefits of robot programming, and how can novel robot programming systems be designed to enable novices to gain a deeper understanding and enhanced control of such advanced design and fabrication methodologies? Progressively difficult robot programming tasks can be designed to measure the acquisition of such knowledge. The first set of tasks involves the control, modification and extension of example robotic processes; the second involves the development of bespoke processes and then their integration into a larger design process. More advanced knowledge and strategies are needed at each stage. Thus the objective of a robot-programming system is not simply to lower barriers to entry but to enable a form of deep learning (Robins et al., 2003) and therefore to enhance the architectural design and fabrication potentials.

Until it can be determined that using only visual notations improves learning success, the present trend of developing robot-programming systems based on such a paradigm may be misguided. Either such systems have negligible effect in improving learning, or they impose an arbitrary ceiling on the knowledge that end-users can acquire. In this case, the focus should be shifted to developing alternative programming systems.

Design and evaluation of a learnable robot programming system

The research is structured in three main stages. The state of the art is reviewed in the first research stage. It begins with end-user programming systems that target the architecture or robotics domains, before focusing on those that specifically address the architect robot programmer.

In the second stage, a robot programming toolkit called YOUR is developed. It is built upon the Rhinoceros/Grasshopper modelling platform and supports both visual dataflow and imperative textual programming approaches. The concept of a progressive abstraction gradient underpins its design. YOUR exposes three layers of abstraction to the end-user (Fig. O2, O3). At the highest level, novice end-users program using visual notations. Eighteen graphical components are provided for sufficient functionality for setting up and controlling simple robotic processes. At the second level, end-users manipulate textual code within the graphical components. They can use abstractions that are missing from the visual programming language in order to build more complex processes. This level acts as a bridge between levels, which employ either purely visual or textual notations. An underlying Python code library constitutes the lowest level of abstraction. End-users, who have acquired sufficient programming and robotics knowledge, can extend the library and define new operations and data types.

In the third research stage, four case studies are set up based on experimental computational design and fabrication scenarios. Subjects are given a set of robot programming tasks to accomplish using YOUR. The effectiveness of the tools in supporting them is assessed through observation and interviews (qualitative), and analysis of their programs (quantitative). These case studies are briefly described below.

Fig. O2 Illustration of using YOUR action component to operate a robotic arm

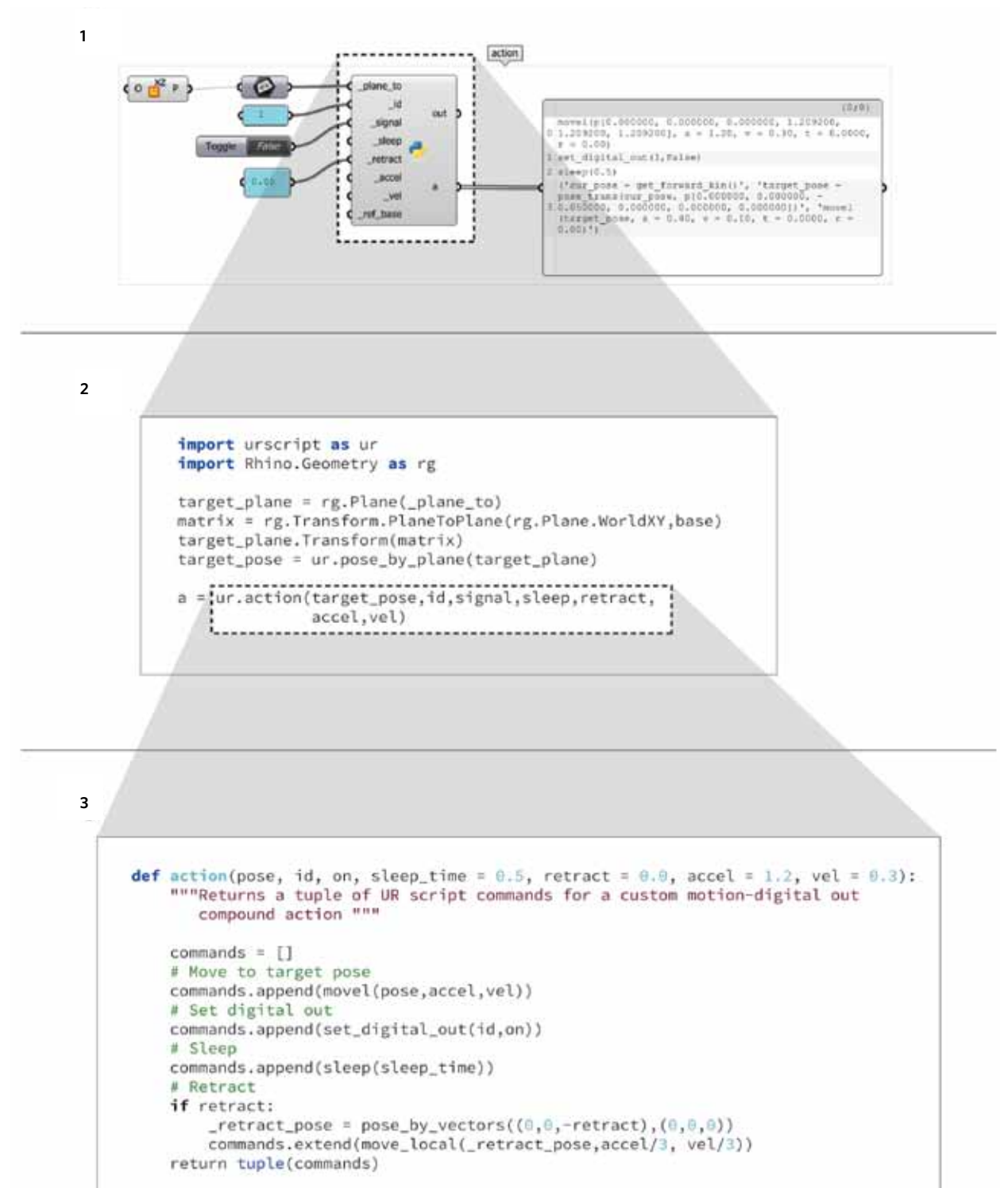
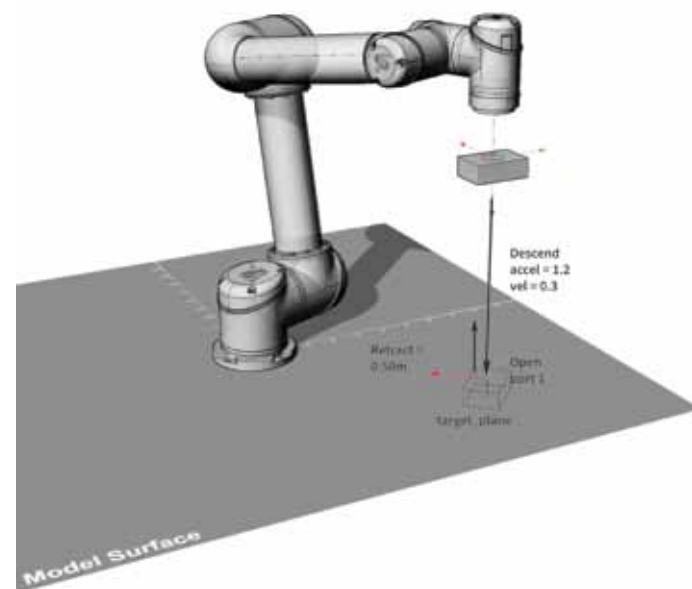

Fig. O3 YOUR exposes three levels of abstraction: 1) at the graphical component level (here the underlying details of an action command are revealed), 2) at the component code level and 3) at the referenced module level

Four Case studies

Design of Robotic Fabricated High Rises 1

The 2012 Design Research Studio took place over two semesters. It involved twelve architecture students organised in three teams. The overall brief of the studio was to design residential high-rises that are differentiated in their spatial, structural and/or programmatic logics. An experimental design methodology was employed whereby robotic fabricated models serve as the primary medium for design exploration. Within the context of the studio, students were given a set of progressively difficult robot programming tasks and their performance was evaluated. The first phase involved the control, modification and subsequent extension of pre-given robotic processes for assembling high-rise models. In the second phase, they were tasked to develop bespoke model fabrication processes that were informed by an overall design strategy (Fig. 04, 05, 06).



Fig. 04, 05 Final tower model assembled out of bent plastic strips (Sylvius Kramer and Michael Stünzi)

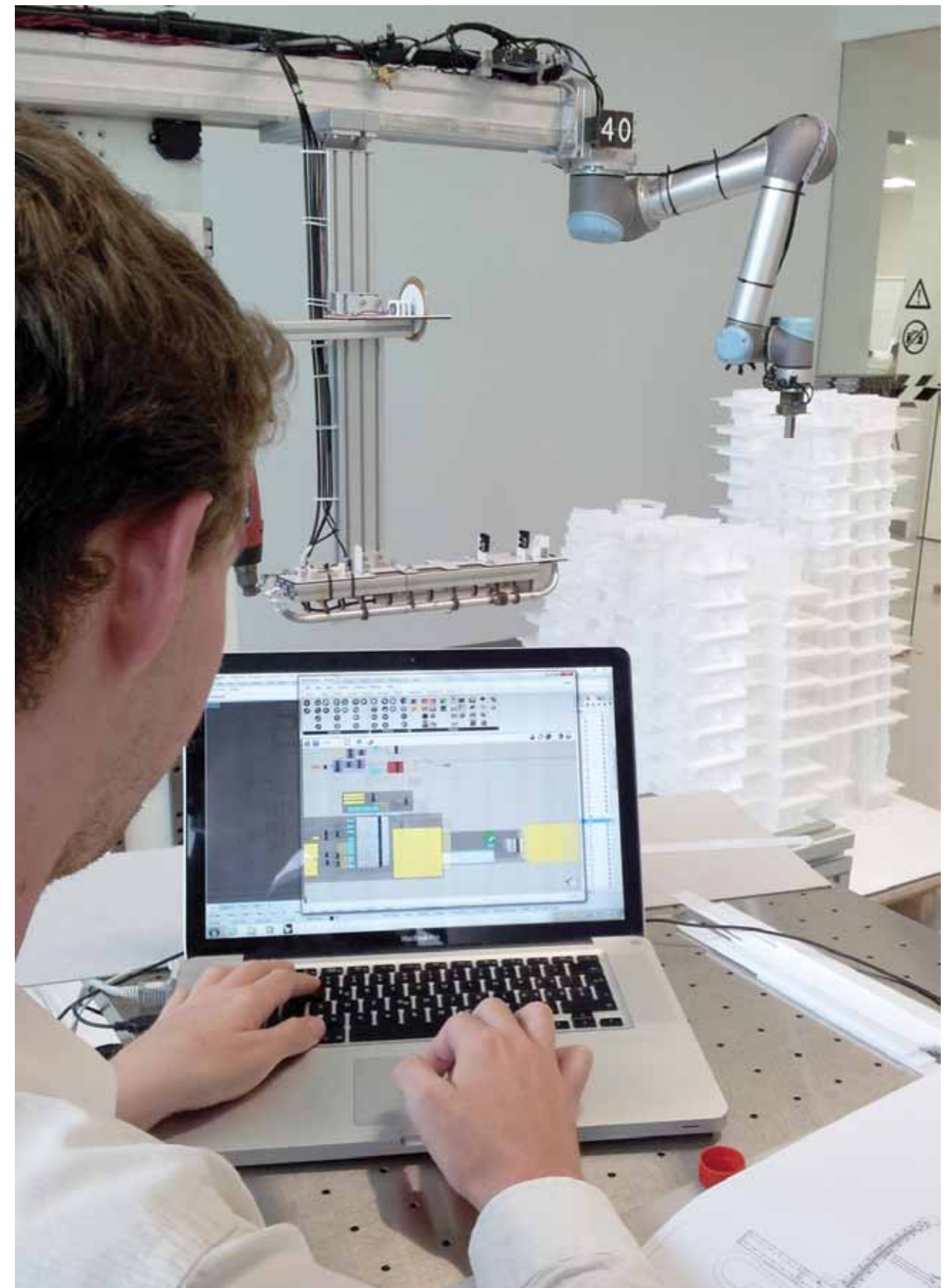
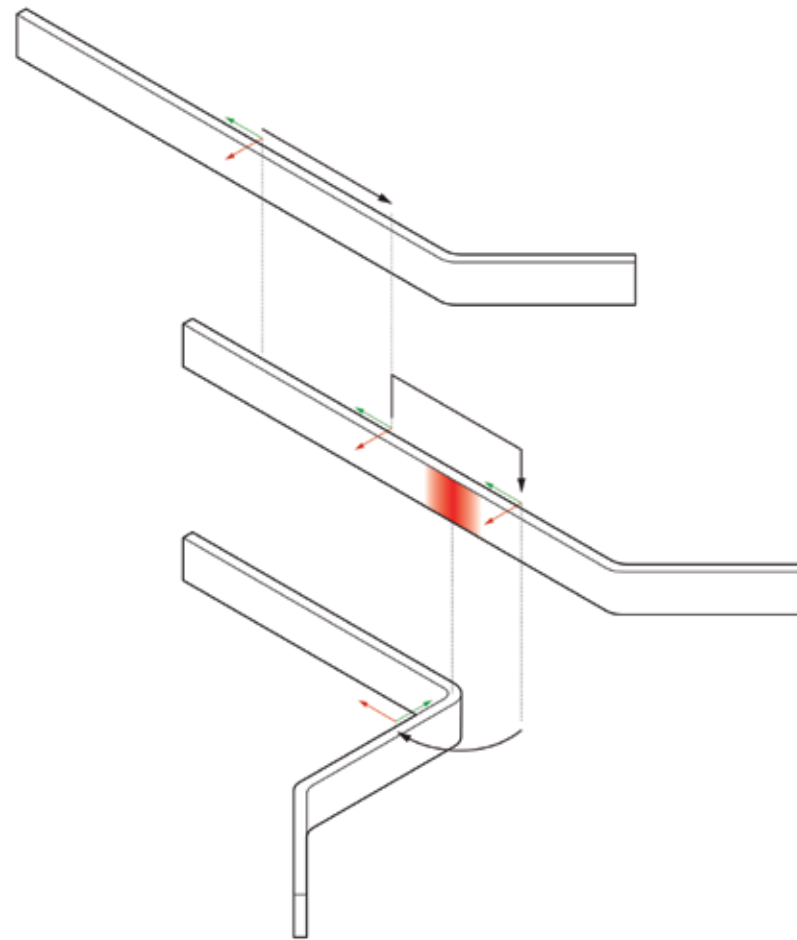

Fig. 06 A student programming a bespoke robotic plastic bending process (Michael Stünzi)

Design of Robotic Fabricated High Rises 2

The Design Research Studio was repeated in 2013 with nine students divided into three groups. The overall studio brief remained the same. Students were given an updated version of YOUR. For the first half of the studio, the focus was on computational design and students worked with a pre-defined pick and place robotic fabrication process. In the second half of the studio, they were tasked to develop bespoke robotic fabrication processes in relation to the developed computational strategy. This second case study was used to corroborate results from the first design research studio. (Fig. 07, 08).

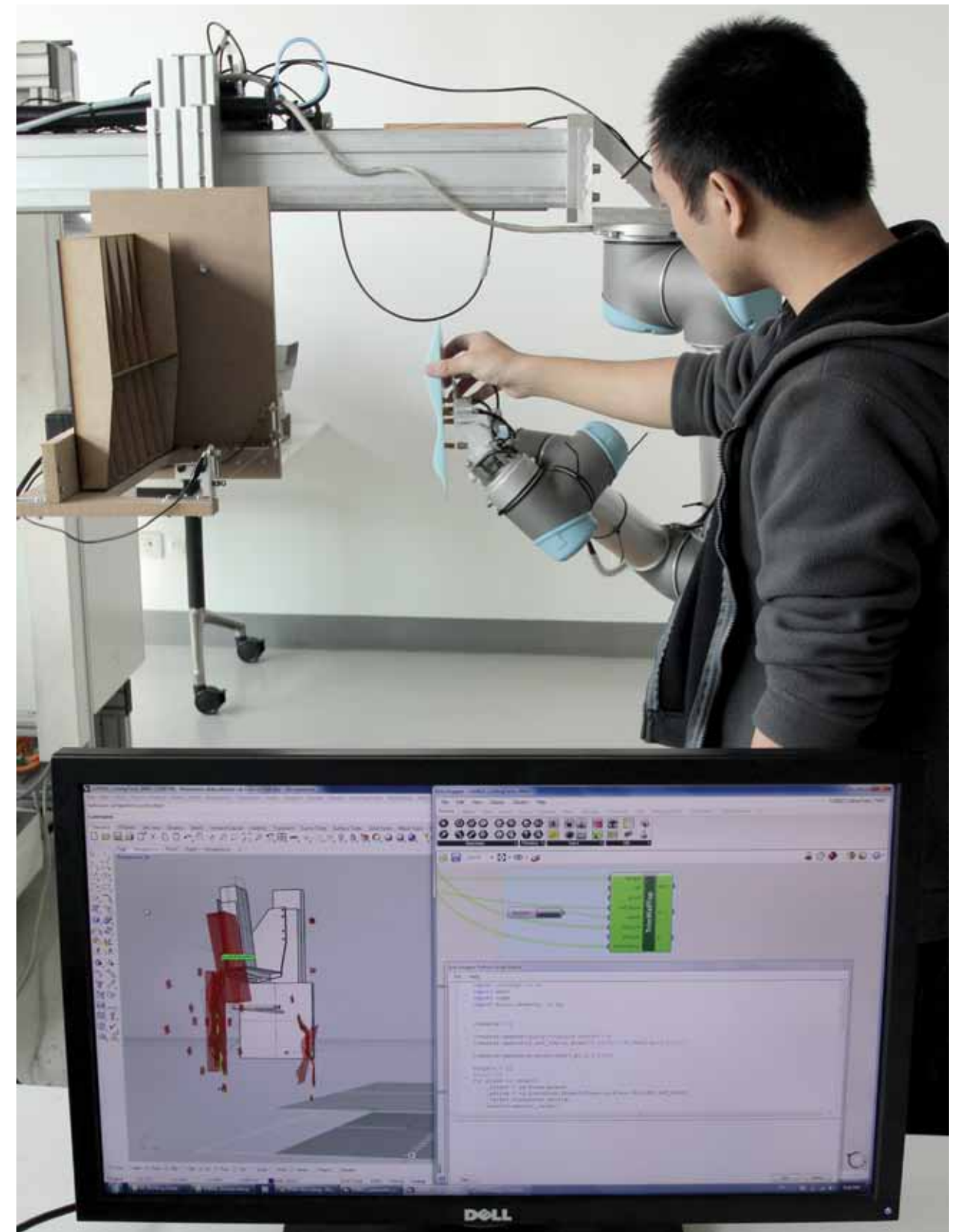
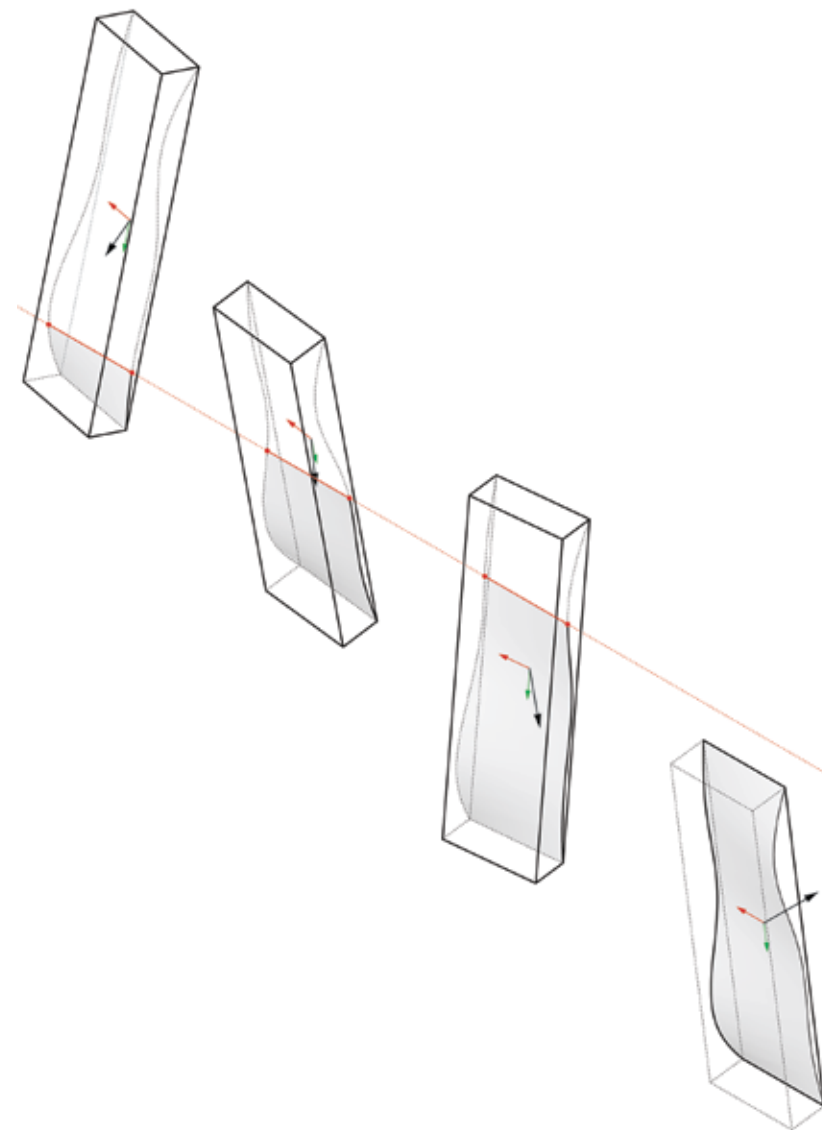

Fig. 07 Final tower model assembled out of individually cut foam elements (Petrus Aejmelaeus-Lindström, Pun Hon Chiang and Ping Fuan Lee)

Fig. 08 Student testing a custom foam-cutting process (Ping Fuan Lee)

Robotic Metal Aggregations

The Robotic Metal Aggregations workshop was run twice – first at the Royal Melbourne Institute of Technology (RMIT) and subsequently at the FCL. The topic was the design and fabrication of metal structures composed of interconnected square profiles. The challenge of the first workshop was to enable participants, who were assumed to have no programming experience, to design their structures within tight time constraints. The objective was to test whether effective design tools could be developed based on the same principles underlying YOUR. In the second workshop, participants had to program the fabrication process as well. They were given an improved version of the design tools alongside YOUR. The goal was to evaluate how an integrated set of tools supported participants in programming both the structures' designs and the robotic process (Fig. 09, 10, 11).

Fig. 09 Participants designing their structures (left - Jonathan Brener and Mark Di Bartolo; right - Clover Chen and Xia Tian)

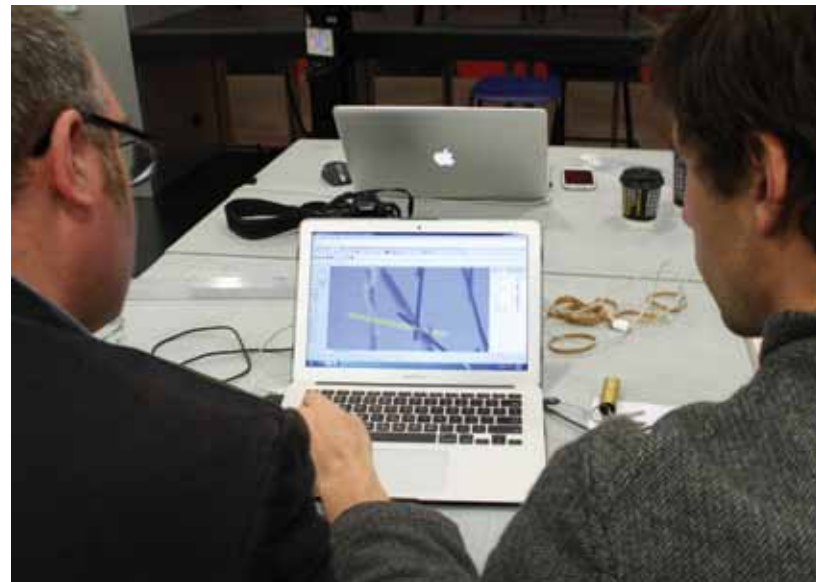

Fig. 10 A robotic fabricated branch



Fig. 11 Participants glue or solder branch segments together (top - James Pazzi; bottom - Chia Zhongying)

Programming Bespoke Robotic Processes

The Bespoke Robotic Processes workshop was conducted at FCL with ten students from the Singapore University of Technology and Design (SUTD). Students had no previous robotics experience, but had some familiarity with both visual and text programming. A simplified version of an assignment given in the Design Research Studio was used in the workshop. On the first day, students were given two example programs built with YOUR and tasked to modify pre-given robotic processes. On the second day, they had to extend one of the programs and develop a bespoke robotic process, such as repeatedly crumpling a plastic strip (Fig. 12, 13) or superimposing multiple cuts on a single foam block (Fig. 14).

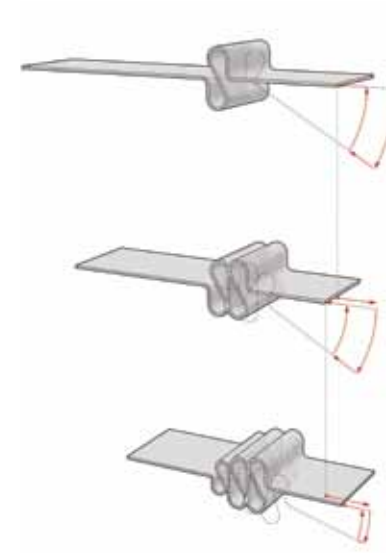

Fig. 13 Results of a modified plastic crumpling program (Clover Chen and Xia Tian)

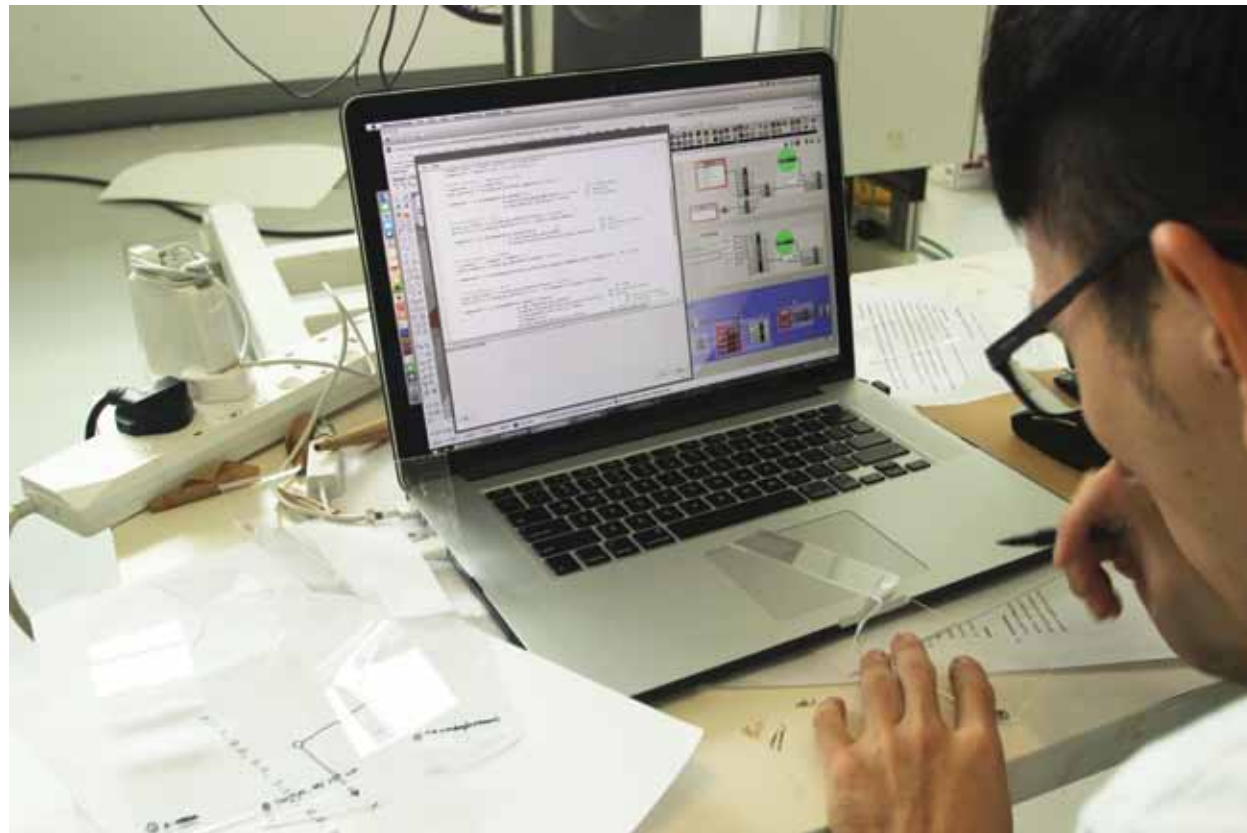

Fig. 12 Participant working out the vector math required to describe the crumpling motion (Leon Cher)

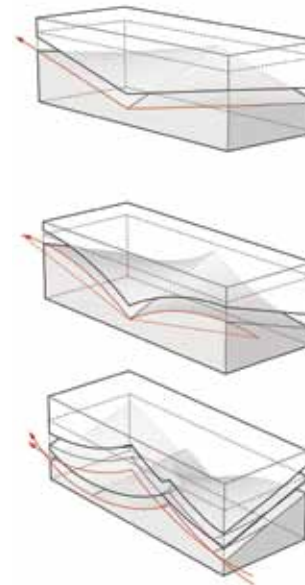

Fig. 14 Results of a modified foam-cutting program (Clifford Kosasih, Lau Jiehao, Amanda Mak)

The results of the four case studies showed that the robot programming system's design directly impacts users' success in performing custom design and fabrication tasks. By providing a high level of abstraction through a small subset of visual components, YOUR enabled complete novices in robotics and programming to control fabrication processes within a short amount of time. At the same time, because it exposes a lower level of abstraction through a text-based application programming interface (API), YOUR also facilitated end-user development of bespoke robotic processes. The focus shifts from designing generative algorithms based on computational geometry to those of a physical and constructive nature. Most importantly, YOUR allowed users to transition smoothly between abstraction levels. This was instrumental in enabling them to gain a deeper understanding of robotics and programming concepts and thus implement more advanced design and fabrication solutions.

Computational thinking through robotics

A key goal of architectural education is to equip students with mental tools that will help them navigate the future professional landscape. Disruptive technologies promise to transform the nature of architectural practice, while emerging issues such as sustainability add new layers of complexity to the already wicked (Rittel and Webber, 1973) design problems architects face. The value of teaching computational thinking (Papert, 1996; Wing, 2006) as another designerly way of knowing (Cross, 2006) becomes apparent. A deeper knowledge of computing concepts would enable architects to gain control over technology, while the ability to think procedurally and utilise abstractions allows them to better handle complexity.

In this regard, the robot could play an important role by serving as a transitional object (Papert 1993 [1980]) between concrete and abstract worlds. As exemplified through the four case studies, computation is demystified and becomes real when students draw a direct link between the abstract notations on-screen and the resultant material artefact. Developing learnable robot programming systems is a first step in enabling more architects to have such empowering experiences. As valuable as the robot has been in allowing architects to fabricate matter, its greater significance may lie in the shaping of minds.

References

- Aish, R. (2005) 'From Intuition to Precision', in Duarte, J., Ducla-Soares, G. and Sampaio, Z. (eds), *Digital Design: The Quest for New Paradigms : 23rd eCAADe Conference Proceedings*. Lisbon: Technical University of Lisbon. p. 10-14.
- Blackwell, A. F. and Green, T. (2003) 'Notational Systems - the Cognitive Dimensions of Notations Framework', in Carroll, J. M. (ed.), *HCI Models, Theories, and Frameworks: Toward a Multidisciplinary Science*. San Francisco: Morgan Kaufmann. p. 103-134.
- Bonwetsch, T. (2012) 'Robotic Assembly Processes as a Driver in Architectural Design', *Nexus Network Journal*, 14(3): p. 483-494.
- Burnett, M. (1995). 'Scaling Up Visual Programming Languages', *Computer*, 28(3): p. 45-54.
- Carpo, M. (ed.) (2013) *The Digital Turn in Architecture 1992-2012*. West Sussex: John Wiley & Sons.
- Cross, N. (2006) *Designerly Ways of Knowing*. London: Springer-Verlag.
- Green, T. R., Petre, M. and Bellamy, R. (1991) 'Comprehensibility of visual and textual programs: A test of superlativism against the 'match-mismatch' conjecture'', in Koenemann-Belliveau, J., Moher, T.G., Robertson, S.P. (eds), *Empirical Studies of Programmers: Fourth Workshop*, New Jersey: Ablex Publishing Corp. p. 121-146.
- Green, T. R. and Petre, M. (1996) 'Usability analysis of visual programming environments: a 'cognitive dimensions' framework', *Journal of Visual Languages and Computing*, 7: p. 131-174.
- Nardi, B. (1993) *A Small Matter of Programming: Perspectives on End User Computing*, Massachusetts: MIT Press.
- Papert, S. (1993 [1980]) *Mindstorms: Children, Computers, and Powerful Ideas*, New York: Basic Books.
- Papert, S. (1996) 'An exploration in the space of mathematics educations', *International Journal of Computers for Mathematical Learning*, 1(1): p. 95-123.
- Rittel, H. W. J. and Webber, M.M. (1973) 'Dilemmas in a general theory of planning', *Policy Sciences*, 4(2): p. 155-159.
- Robins, A., Rountree, J. and Rountree, N. (2003) 'Learning and Teaching Programming: A Review and Discussion', *Computer Science Education*, 13(2): p. 137-172.
- Willmann, J., Gramazio, F., Kohler, M. and Langenberg, S. (2012) 'Digital by Material: Envisioning an extended performative materiality in the digital age of architecture', in Brell-Cokcan, S., Braumann, J. (eds), *Robotic Fabrication in Architecture, Art, and Design*. Vienna: Springer. p.12-27.
- Wing, J. M. (2006) 'Computational Thinking', *Communications of the ACM*, 49(3): p. 33-35.
- Winslow, L. E. (1996) 'Programming pedagogy - a psychological overview', *ACM SIGCSE Bulletin*, 28(3): p. 17-22.

Endnotes

¹ Each step-by-step instruction must be explicitly specified. Higher-level instructions are specified at the task level, thus such detail is unnecessary.

² In the last four years, five plugins for the Grasshopper visual programming environment were made publically available: Kuka PRC, HAL, Godzilla, Crane and Scorpion.

Acknowledgements

I would like thank Dr. Robert Aish for his feedback and guidance. In addition, I would like to express my gratitude to all the students, workshop participants and supporting faculty members from RMIT, NUS, and SUTD. Finally, I would like to thank Ammar Mirjan for collaborating on the Robotic Metal Aggregations workshop.

Mesh Mould

Robotic fabrication for non-standard concrete constructions

Norman Hack, Willi Lauer

The robotic laboratory at the Future Cities Laboratory (FCL) was set up to investigate the potentials of non-standard robotic fabrication for high-rise constructions in Singapore. The high degree of industrialisation of this dominant building typology implies standardisation, simplification and repetition and accounts for the increasing monotony evident in many Asian metropolises. The aim of this research is to develop a novel construction method that makes full use of the malleable potential of concrete as a building material. A new spatial robotic 'weaving' technique of a tensile-active material, which simultaneously acts as the form-defining mould, folds two separate aspects of concrete reinforcement and formwork into one single robotic fabrication process. This in situ process could permit the digitally controlled fabrication of structurally differentiated, spatially articulated and materially efficient building elements.

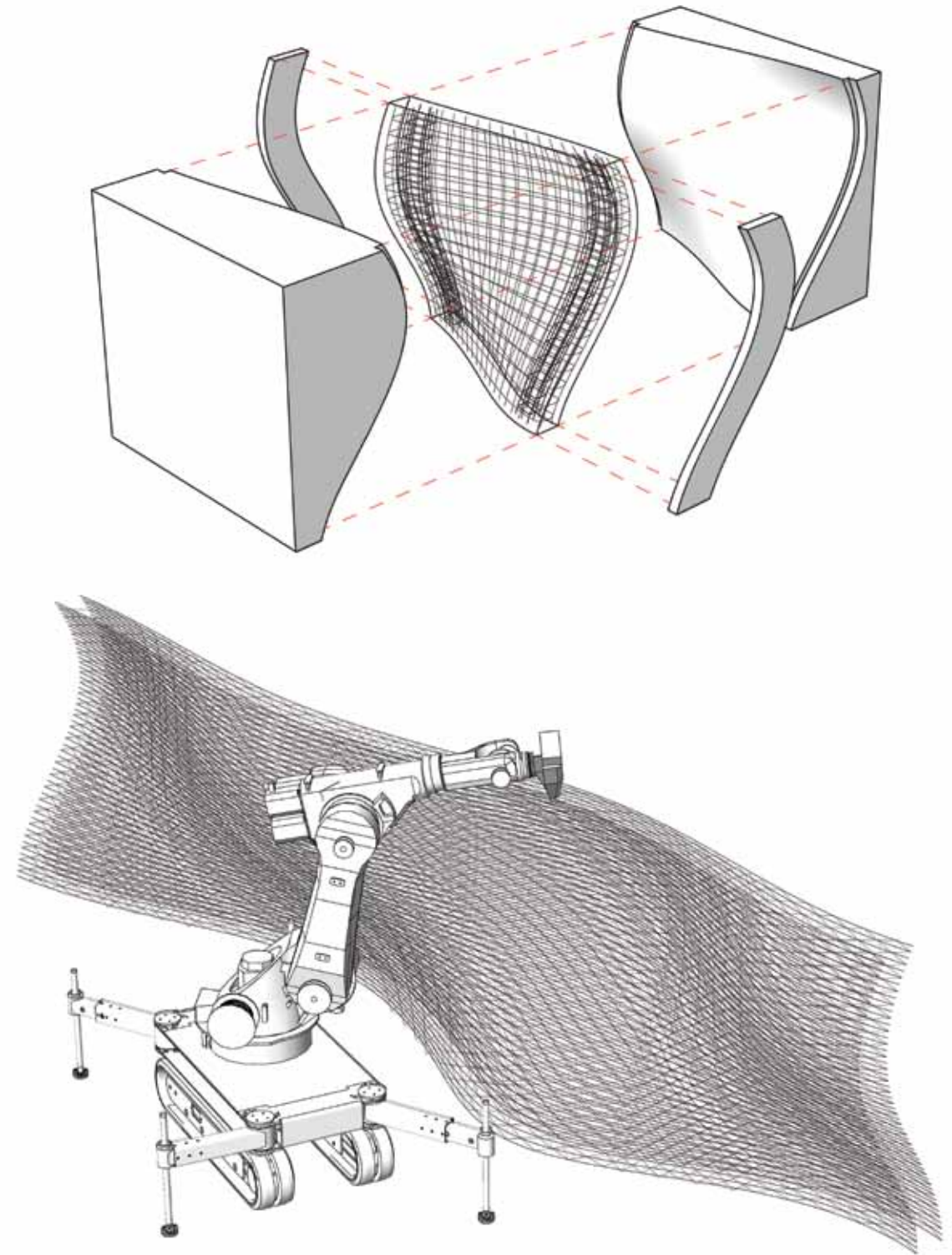

Fig. 01 Conventional construction of reinforced concrete elements and Mesh Mould – the largest share of costs of a concrete structure is caused by the labour-intensive construction of formwork. Bending and placing of reinforcement accounts for another significant share of the cost. Mesh Mould proposes a unification of these two systems into one combined formwork-reinforcement system. These three-dimensional mesh structures are robotically fabricated in an additive, waste-free process, permitting an increase in geometric complexity without raising the costs

Industrialisation of the building site

Compared to other manufacturing sectors the degree of industrialisation in architecture and the building industry is rather low. Even though components and building elements of architecture, such as bricks, steel beams and concrete panels, are industrially prefabricated, they are usually not automatically assembled. Human labour clearly predominates in the assembly process on-site. This is a fundamental difference to other industries, like the automotive industry, in which the entire process from production of parts to final assembly is industrialised and often fully automated. The reason for this is obvious: buildings are not industrial mass products, but most often unique and customised for the individual needs of a client and a specific site. Additionally, the prefabrication of large building elements is constrained by transportation. Therefore large elements are generally manually produced on-site instead of being industrially prefabricated in a factory. Despite these unfavourable preconditions for the complete industrialisation of construction, automation processes have been the subject of research for several decades. Starting with the prefabrication of building components, there has been a noticeable trend towards the automation of the entire assembly process on the building site. The first ideas for rationalisation through mass production of building elements, which were developed in the early 1910s, were implemented to a larger extent only in the 1960s and 1970s. In the following decades, most notably in the 1980s and 1990s in Japan, the absence of qualified labour concurrent with the enhancements in data handling and logistic control has spurred an increased research in on-site construction automation.¹ However, these automation endeavours have been successful only to certain extent. The primary goal of reducing human labour was achieved, but in turn the automation process required such a high degree of standardisation that the resulting architecture was too inflexible and repetitive to sustain the demands of planners, users and changing economic circumstances. Further technological advancements at the beginning of the 21st century, such as ubiquitous computational power and the availability of cheap off-the-shelf industrial robots,

have extended the field of possibilities for computer-controlled fabrication and new architectural expressions dramatically. The combination of computational power, advanced sensor technology and the high flexibility of industrial robots now allow for application of robotic systems directly at the building site. Robotic in situ fabrication has the potential to close the circle for a fully industrialised construction process and offers new modes of production which reach beyond rationalisation and mere automation.

In the realm of architecture, and especially with regard to mass housing, the high-rise is often seen as the embodiment of industrialised construction and mass production. This particularly applies to the many fast-growing Asian metropolises. In this context the unique set-up of the research project Design of Robotic Fabricated High Rises at FCL in Singapore allows investigations into the potentials of robotic fabrication for the design and construction of high-rises. The particular condition of mass housing in Singapore offers an optimal test bed for the research on innovative building processes. An increasing population growth and the scarcity of land challenge Singapore to deal with further densification; the high-rise is an obvious solution at hand. By launching the Building Control Act, the Singapore government expressed its support for the application of industrialised and automated building processes in order to achieve higher overall productivity, better construction quality and to be less dependent on manual labour. These preconditions are favourable for the investigation of computer-controlled fabrication processes, as their strength and benefits have multiplier effects. In contrast to pure automation, the flexibility of robotic fabrication processes has the potential to defy the prevailing 'one-size-fits-all' approach of standard high-rise construction in Singapore. On a programmatic level it can promote substantial variation in structures in order to accommodate more diverse architectural programmes. In terms of material efficiency, robotics could allow the fabrication of structurally optimised and geometrically complex building components well adapted to the forces that act upon them (Fig. 02).

Fig. 02 One size fits all vs. differentiation - structural differentiation not only allows the design for ideal force progression, but also enables greater architectural freedoms. Even the notion of the construction site changes towards a decentralised and distributed system. Not a classical plan or preconceived design ideas, but digital data and explicit design logics determine the shape of the building

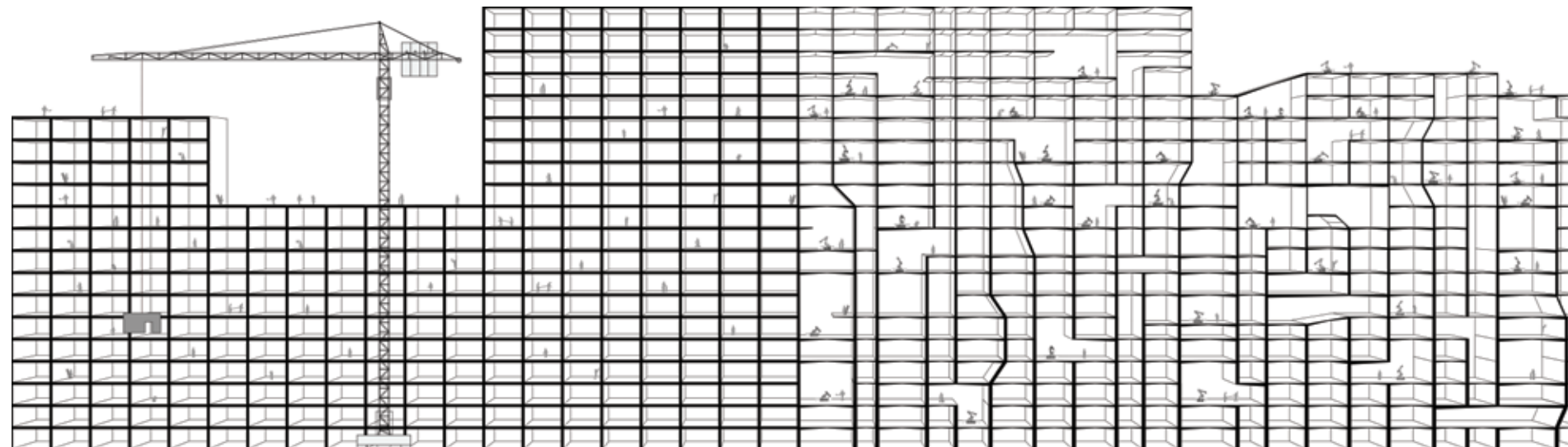

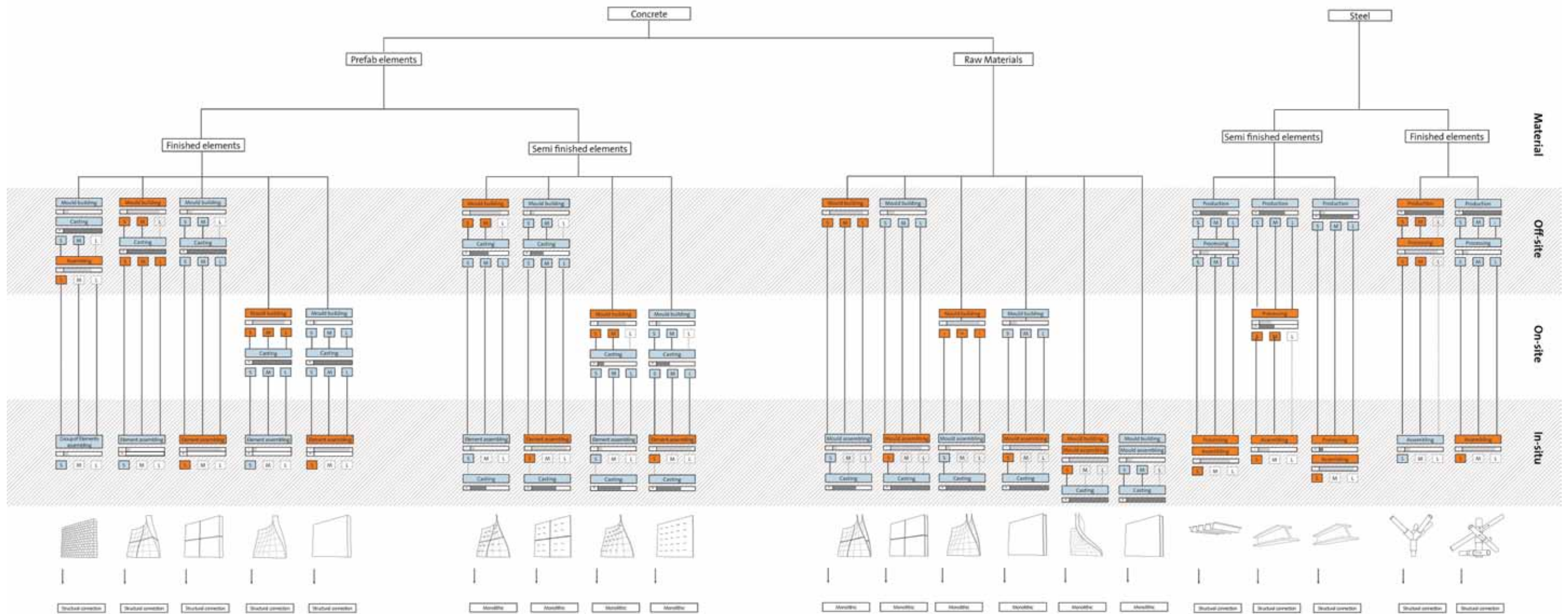

Fig. 03 The diagram illustrates a selection of construction processes for load-bearing structures and identifies feasible paths, which allow the introduction of new geometric freedoms with the smallest possible need for substantially new machines and complex logistics. Determining at which point in the process chain geometric information and construction materials are merged with least effort suggests that a formwork system constitutes the most feasible principle

Mesh Mould

Based on the finding that a construction process for robots needs to be lightweight, the decision was taken to focus on the robotic fabrication of concrete formwork (Fig. 03). Instead of having the robot transfer the entire mass of the building it is used to define the shape of the structure, and therefore to take over those tasks which are coordinatively complex, and highly labour- and cost-intensive (Fig. 04). One specific formwork system called leaking formwork was found to be particularly interesting and offered great potential to be adapted for a robotic process. Its basic principle works as follows. Concrete is poured into a perforated formwork, which is built up from flat plastic panels. The concrete protrudes through the perforations and covers up the panels. In a final step the surface is manually trowelled leaving behind a smooth concrete surface (Fig. 05).

This simple and efficient material system holds great potential when crossbred and augmented with the logic of robotic fabrication. If the perforated formwork is directly extruded in situ as three-dimensional spatial meshes by a robotic arm, instead of being composed of discrete prefabricated panels, the system is liberated from planarity or single curvature. In addition to the primary goal of unlocking the full plastic potential of concrete as a building material, the discussed research aims at activating the meshes as structural reinforcements.

However, in order to get a better hold on the ambitious overall aim, to entirely substitute the conventional reinforcement, the implementation follows sequential steps. After an initial concept-finding phase a first experimental phase is focusing on the form-defining capacity of the meshes via the spatial extrusion of polymers, whereas a second phase focuses on the bending and welding of steel-wire meshes with increased load capacities. After three years the research will conclude with a final demonstrator. The following sections describe the development and current state of the research project.

Fig. 04 Cost of formwork - the diagram shows the cost distribution of reinforced concrete construction. Formwork and reinforcement take the largest share, which means that these are also the two aspects where actual additional value could be added

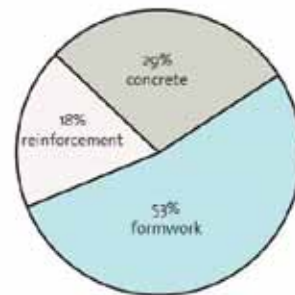

Fig. 05 Forma-Tech formwork system - the corrugated plastic panels are clipped together on-site, holding in place the vertical and horizontal steel reinforcement. A fairly fluid concrete is tuned to entirely flow around the steel reinforcement and the plastic panels, but still needs to be viscous enough to not completely leak out of the perforations. Since the operator can see through the perforated plastic panels during the concrete pouring process, he can subsequently densify cavities; hence there is usually no need to vibrate the concrete

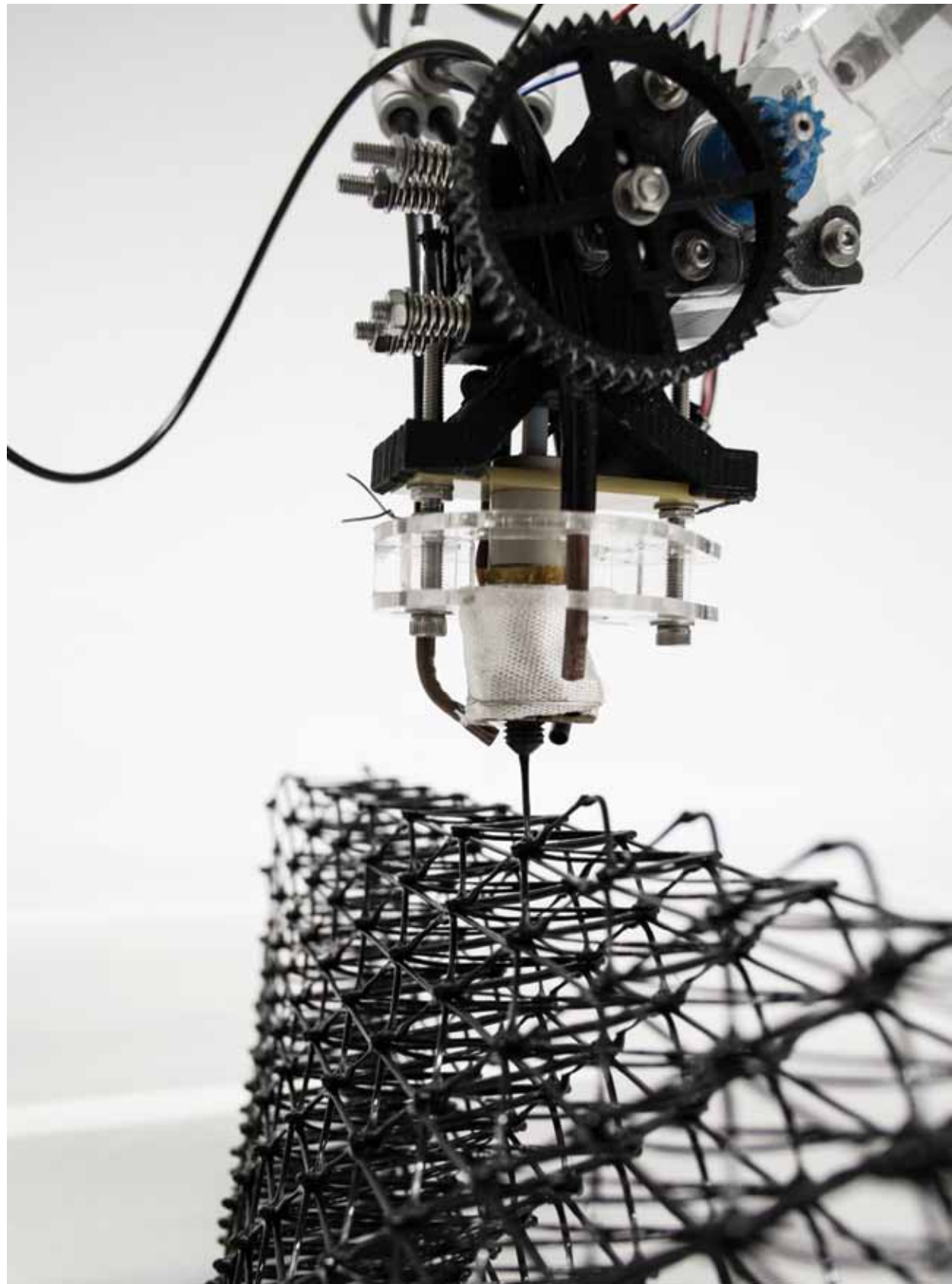

Fig. 06 First spatial extrusions on UR5 – spatially unrestricted movements are the most critical part of the extrusion process, as here the material must be cooled down in order to gain sufficient stiffness to resist the load of the extruder moving downwards. This is also the most time-consuming part of the process

Polymer meshes

The experiments conducted until now offered key insights about the potential of spatial, non-layer-based extrusion of polylactic acid (PLA) for the fabrication of spatial meshes. The availability of a standard 3 mm PLA filament allowed running the first experiments by using off-the-shelf 3-D printer extruder and feeder components. The integration of a custom cooling system based on pressurised air, which locally hardens the material in the moment it is extruded, has been key to the ability to extrude material freely in space. The motion path for the robot was directly generated by a custom algorithm generating three-dimensional mesh structures from any arbitrary pair of surfaces. The samples created were doubly curved meshes with dimensions of approximately 600 x 500 x 250 mm, an aperture size of 30 x 20 x 20 mm, extrusion diameter of 2 mm and a total volume fraction of the mesh of 2.5% (Fig. 06, 07). The apertures size of these first samples represents approximately 1:1 scale; however, the global geometry remained a fraction of a larger non-specified element. Aperture size, extrusion thickness and global geometry will be adjusted according to the results of subsequent concrete-pouring tests.

Fig. 07 First spatial extrusions on Universal Robots UR5 – the liberty afforded by spatial extrusion enables the resulting mesh structures to conform with the required structural performance by specifically adapting their density. At the current state, the robotic extrusion technique can process different kinds of thermoplastic materials. The conceptual change from layer-based deposition to spatial extrusion has noteworthy implications. Whereas the former remains generic, mostly for the representation of form, the digitally controlled spatial extrusion becomes specific to the architectural construction and allows for a significant and simultaneous reduction of both production time and weight



Fig. 08 Incorporation of material parameters - the planned deviation of the robot motion path from the designed element geometry mirrors exactly the deviations caused by the material properties of the thermoplastic material, so that both even out each other and a consistent fabrication quality is achieved. However, the adjustment parameters also vary with the quality of the used polymer material, even within one class of polymers, so that it is not sufficient to calibrate it once and store these values. On the contrary, every new batch of polymer requires repeated calibration

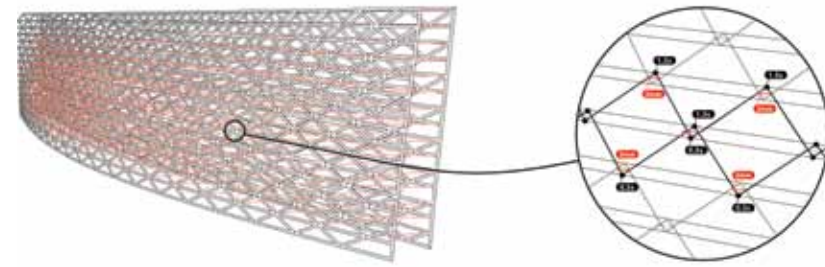

Fig. 09 Tool head diagram - the two most important design criteria for the development of an appropriate class of extruders are the heating power, effectiveness of the cooling mechanism and the actual geometric versatility of the extrusion die. The close vicinity of extreme heat and strong cooling is a characteristic of this tool. Disadvantageous effects of this configuration can only be prevented if a balance of heating power, insulation and heat exchange exposure is maintained. Therefore the pin point cooling concept was abolished in favour of an air shower design which made use of a stream of air flowing alongside the conically shaped tip. This allowed the reach of a larger section of extruded filament. Hitting a larger section of filament means having a more powerful heat exchange

While some constraints can easily be solved by clever motion planning, others require adjustments in hardware. The collision-free extrusion of material at steeper angles, for example, can only be enabled by a custom design of the extruder head (Fig. 09, 10). The experiments have shown that increasing the extrusion rate in order to speed up the process requires a more efficient cooling mechanism.

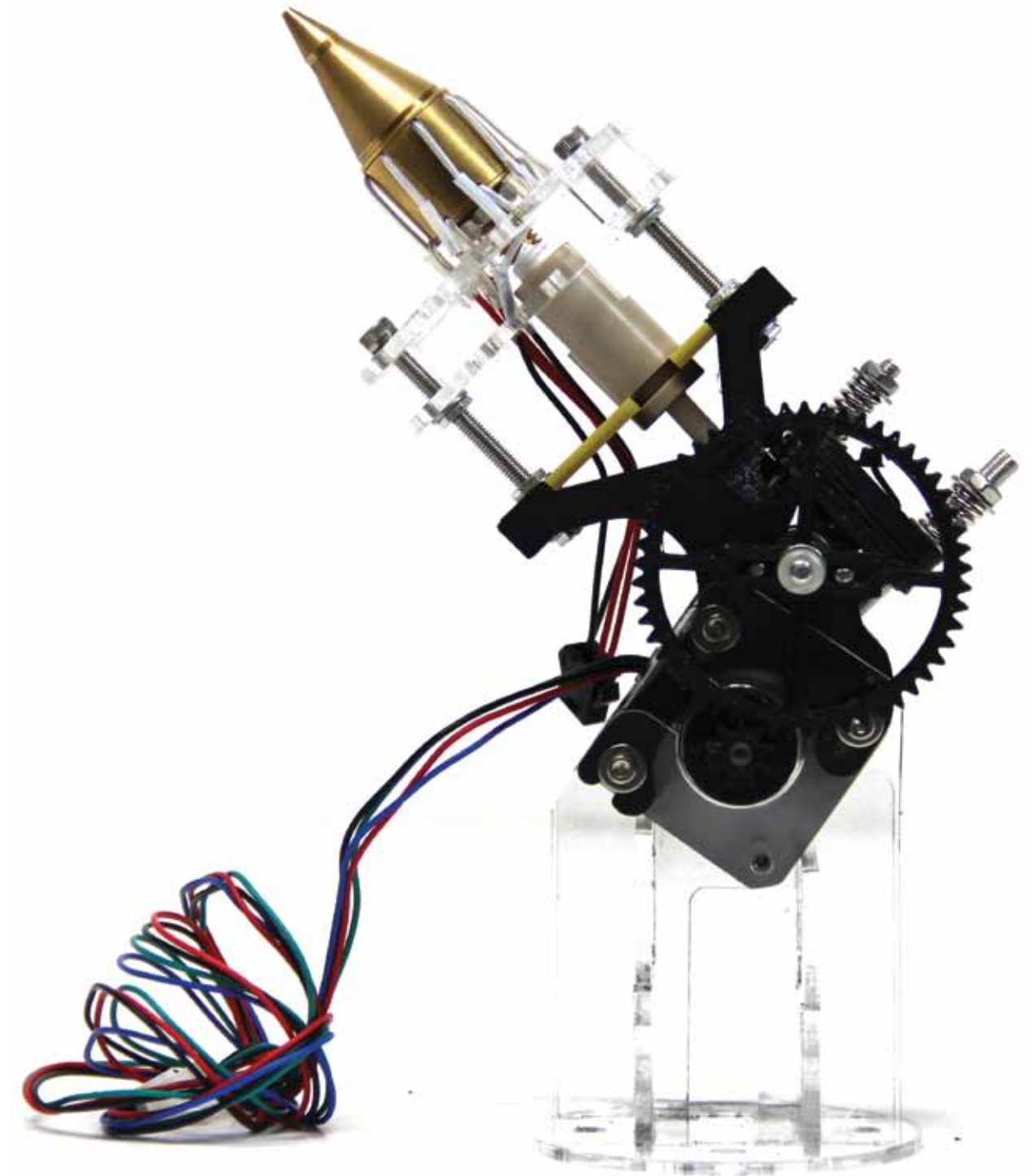
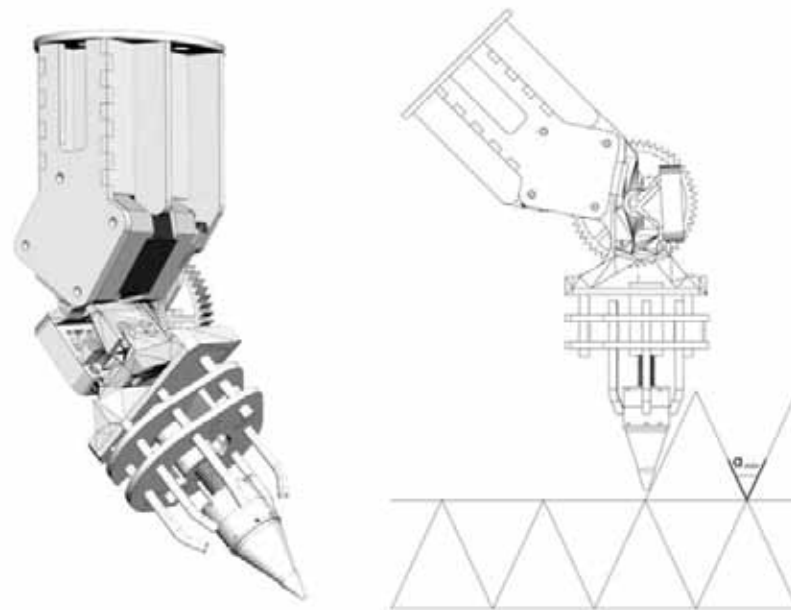

Fig. 10 Second-generation extruder - integration of a custom cooling system based on pressurised air that hardens the material locally at the moment it is extruded has been key to the ability to extrude material freely in space

Mesh differentiation

The following section retraces the development from simple triangulated 3-D lattices towards more differentiated spatial structures in accordance with the diverse requirements and pressures acting upon these meshes. The requirement to differentiate the meshes has been an assumption that was confirmed by the first concrete experiments. Due to the high complexity and the manifold interacting parameters the differentiation of the mesh structures happened through several iterations of physical experiments, rather than through digital simulation. More generally the diverse, partly conflicting, partly overlapping requirements can be classified into the following domains.

First, optimised flow of concrete: On one hand the structure and aperture size of the mesh need to be sufficiently dense in order to keep the concrete from bleeding out; on the other hand it needs to be wide enough so that the concrete can flow evenly around the structure without causing congestions or voids.

Second, structural considerations: The four load cases that influence the meshes are firstly the dynamic loads acting on the mesh during the process of pouring, secondly the hydrostatic pressure building up inside the formwork as long as the concrete is in its liquid state, thirdly the wet load of the concrete before curing and lastly the tensional loads acting on the element after the concrete has cured and the element is structurally loaded.

Third, material use and fabrication time: The mesh topology, density and the extrusion path have a significant impact on the amount of material that is used and the time that is needed to fabricate the meshes.

The following experiments started with simple, undifferentiated meshes describing complex surface geometries. The following concrete tests gave an impression about the behaviour of the mesh under wet load, while successively more complexity was discovered when examining the rheological behaviour of the concrete within the mesh.

Physical experimentation at multiple scales

The main objective of the first prototypes was to prove that a spatial extrusion even for complex double-curved surfaces is achievable. The concrete for these experiments was not applied by pouring it inside the mesh and letting it protrude to the outside but rather, as in classical ferrocement applications, by pressing a fairly viscous mortar from the outside through the mesh, successively densifying the interior. Even though this strategy proved successful it was considered too labour-intensive for larger building elements. After applying 35 kg of wet concrete no mesh deformations were recognisable, even though the mesh itself accounts for only 1% of the wet load of the concrete.

Large scale extrusions

In order to prove the robustness of the extrusion process over extended periods of time and greater heights larger-scale prototypes were fabricated at ETH Zürich. The same extrusion head as for the previous experiments, but with bigger, 3-mm-extrusion nozzle was used in order to extrude a simple, singly curved 'S'-shaped wall segment.

The experiments showed that from a height of approximately 1 metre the structure became slightly unsteady, which can be traced back to the slenderness of the sample. Thin tension cables helped to stabilise the sample, which was then extruded up to a height of 1.8 metres. Replacing the horizontal interior structure with more vertically oriented cross-bracing is expected to further increase the resistance against lateral forces. A sample of 70 x 15 x 180 cm was extruded in approximately 30 hours (Fig. 11, 12).

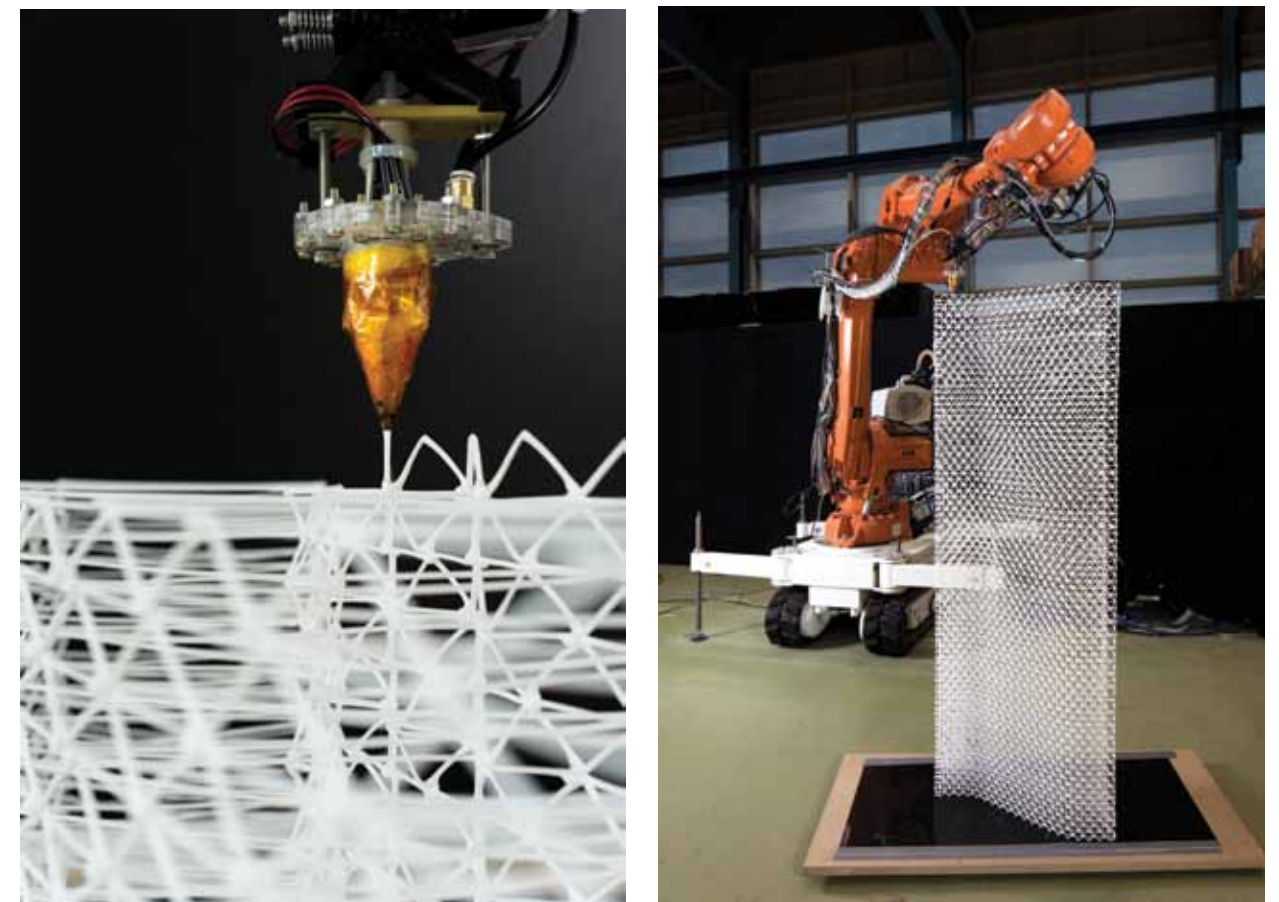

Fig. 11, 12 Extrusion process of large sample – as a prototypical set-up for a process that is based on collaborative multi-agent in situ fabrication, larger-scale experiments are carried out on an ABB IRB 4600 industrial robot, mounted on a mobile platform. The direct extrusion of the formwork in situ allows for greater geometric complexity while simplifying the process itself. Since the amount of needed material is reduced to a minimum, such an approach holds a high potential for resource efficiency. In addition to various scaled experiments, a 1:1 setup was tested in which the mobile robotic unit extruded a 1.80-metre-high mesh formwork. Fabricated with an extrusion thickness of 2.5 mm, the final sample weights merely about 3 kg



Fig. 13 Prototype



Fig. 14 Test cubes after curing - the samples have not been vibrated. The samples using a less viscous concrete display a certain degree of honeycombing and the inclusion of voids

Pouring test cubes

In parallel small test cubes with a variety of mesh apertures were fabricated in order to find an appropriate relationship of concrete viscosity and mesh aperture size as well as to examine the rheological behaviour of concrete within the mesh during the process of pouring. These have been tested with a specific concrete mix, once with the addition of fibres, once without. The admixture of fibres resulted in clogging within the dense interior structure. A mix without fibres worked best at a slump flow of 19 cm measured with the Hagerman's mini-slump cone. Generally the interior structure was regarded as too dense in relation to the exterior structure, not allowing the concrete to flow evenly around the structure (Fig. 14).

Pressure columns

Directly following, and building up on the previous experiments, a third series aimed to test the structural integrity of the meshes during the process of pouring. It was examined whether the structures can withstand the high pressure of the wet concrete, and whether the meshes are actually capable of holding back the wet concrete with increasing pressure from above. A series of test cubes, again with an edge length of 15 cm and varying number and sizes of apertures was placed at the bottom of one 15 x 15 x 150 cm pressure column (Fig. 18). A specified concrete was then filled into the column from the top. The level of maximum possible infill was registered when the mesh could not hold back the concrete or broke under the load.

The experiments showed that none of the meshes broke due to the weight of the concrete. However, despite the high pressure, the interior structure of the meshes was too dense. Concrete without fibres and a slump flow of approximately 19 cm worked well up to the maximum infill height. A combination of the three-dimensionality of the mesh and the thixotropic effect of the concrete sealed the mesh surface immediately after initial trowelling, enabling more concrete to be filled from the top without any concrete leaking out.

Findings of calibration experiments

The experiments gave insight into the required concrete and mesh parameters. With regard to the concrete, a combination of an aperture size of approximately 30 x 17 mm and a slump flow of 19 cm was found to work best. The concrete should stay at a specific slump flow for the duration of the pouring process. The thixotropic effect of the concrete is highly beneficial to the leaking formwork system, and could further be stimulated by adding thixotropic agents. However the general finding was that the inner structure was too dense compared with the outside structure. The assumption is made that through reducing the inner flow resistance of the meshes a better distribution of the concrete and less honeycombing can be achieved.

Mesh refinement and differentiation

Based on the findings of the previous experiments a new series of differentiated meshes was developed, aiming to improve the structural integrity, enhance concrete flow and material distribution within the meshes and to reduce fabrication time and material consumption. These goals can be achieved by a variety of means and strategies. The reduction of flow resistance in the interior, for instance, might enhance the concrete flow, reduce fabrication time and material use but at the same time weaken the structural capacity of the mesh. Like in many multi-parameter optimisation tasks, here the goal is to find a well-balanced solution for the various, competing parameters. The samples measure 80 x 30 x 15 cm and represent a section of a single curved wall (Fig. 15, p. 54, 55).

The fabrication time for each sample is taken by stopwatch and the amount of used material is determined by the mesh's weight. The ratio of material used for the perimeter-defining surfaces and inner structure is determined by the quotient of the path lengths and describes where the flow resistance is higher. Structural tests are undertaken for two different load scenarios: a combination of compression and shear force as well as a 3-point bending test. Since the samples are not representing the actual material these results solely compare the geometry-related structural performance. A beam with the dimensions of 50 x 5 x 10 cm was fabricated for each of the six patterns and deflections are measured under the influence of a constant force (Fig. 16).

Evaluation through pouring

The pouring tests for the differentiated samples were conducted in collaboration with Holcim Singapore. The concrete manufacturer developed and tested various concrete recipes, with the conclusion that a standard concrete mix with an aggregate size of 10 mm and low water content (W/C ratio = 0.36) worked best. The mesh typologies DOD, 2D2D and DD_Ducts_Hex were tested, whereas the remaining meshes SD, SOS_Ducts, DD_Ducts_Hex displayed a too dense interior in which apparently the concrete could not sufficiently distribute. These typologies have not been filled. In order to

avoid honeycombing the concrete has been filled up to a height of approximately 30 cm and was then vibrated with a 2.5-cm-diameter poker vibrator. After vibrating a successive layer of concrete was poured and vibrated again (Fig. 17).

As expected the 2d2d mesh performed best. The folding of the outer perimeter stabilised the mesh and guaranteed form stability (Fig. 18). The other mesh typologies displayed slight deformations under the weight of the concrete.

Conclusion for polymer cycle

The standard polymer used for the fabrication of the meshes proved to be a cheap and versatile material, ideal for the exploration of the design space of the meshes. This design space includes differentiated mesh typologies, various object scales and a wide variety of surface curvatures. However, in order to reach and test the full load-bearing potential of the meshes extensive material research into fibre-reinforced polymers would have to be undertaken. Hence the focus for the next phase of the research is directed to an alternative material process, namely metal wire.



Fig. 17 Filling of 2D2D mesh type – the viscosity of a standard concrete mixture can be locally graded to enable control of the protrusion rate at the mesh perimeter by using a vibrating poker. Along an effective radius of 10 cm, the vibration causes the material to lose viscosity due to its thixotropic properties



Fig. 18 Cured sample, one side untreated – fine tuning of the protrusion rate enables influence of the mesh coverage ratio towards a favourable surface finish. Hence the concrete has stopped protruding through the mesh apertures; the bond between mesh and concrete intensifies quickly, which makes subsequent unintentional protrusion unlikely

Fig. 16 Quantification of results – the abbreviations describe the pattern of the interior structure. 'S' stands for a 'straight' connection e.g. from the first point of the right perimeter to the first point of the left perimeter. 'O' describes an 'on beam' connection, e.g. for two consecutive points on the same perimeter, while 'D' represents a diagonal connection of two points, e.g. the first point on the left perimeter and the second on the right perimeter

		Weight per sample	Fabrication time per sample	Ratio Inner to outer structure	3 point bending cm; 1 kg load	Deflection shear and pressure cm, 2kg load
SD		649 gr	9h 3min	1.91	0.8 cm	X = 0.2 cm Y = 0 cm
DOD		352 gr	5h 36min	0.53	7.5 cm	X = 3 cm Y = 10cm
2D2D		446 gr	7h 18min	0.21	1.5 cm	X = 2 cm Y = 11cm
DD_Ducts		418 gr	6h 33min	0.63	2 cm	X = 0.2 cm Y = 0.6 cm
SOS_Ducts		464 gr	6h 51min	0.81	8 cm	X = 1.6 cm Y = 0.6 cm
DD_Ducts_Hex		538 gr	7h 42min	1.23	9.5 cm	X = 0.5 cm Y = 0.1 cm

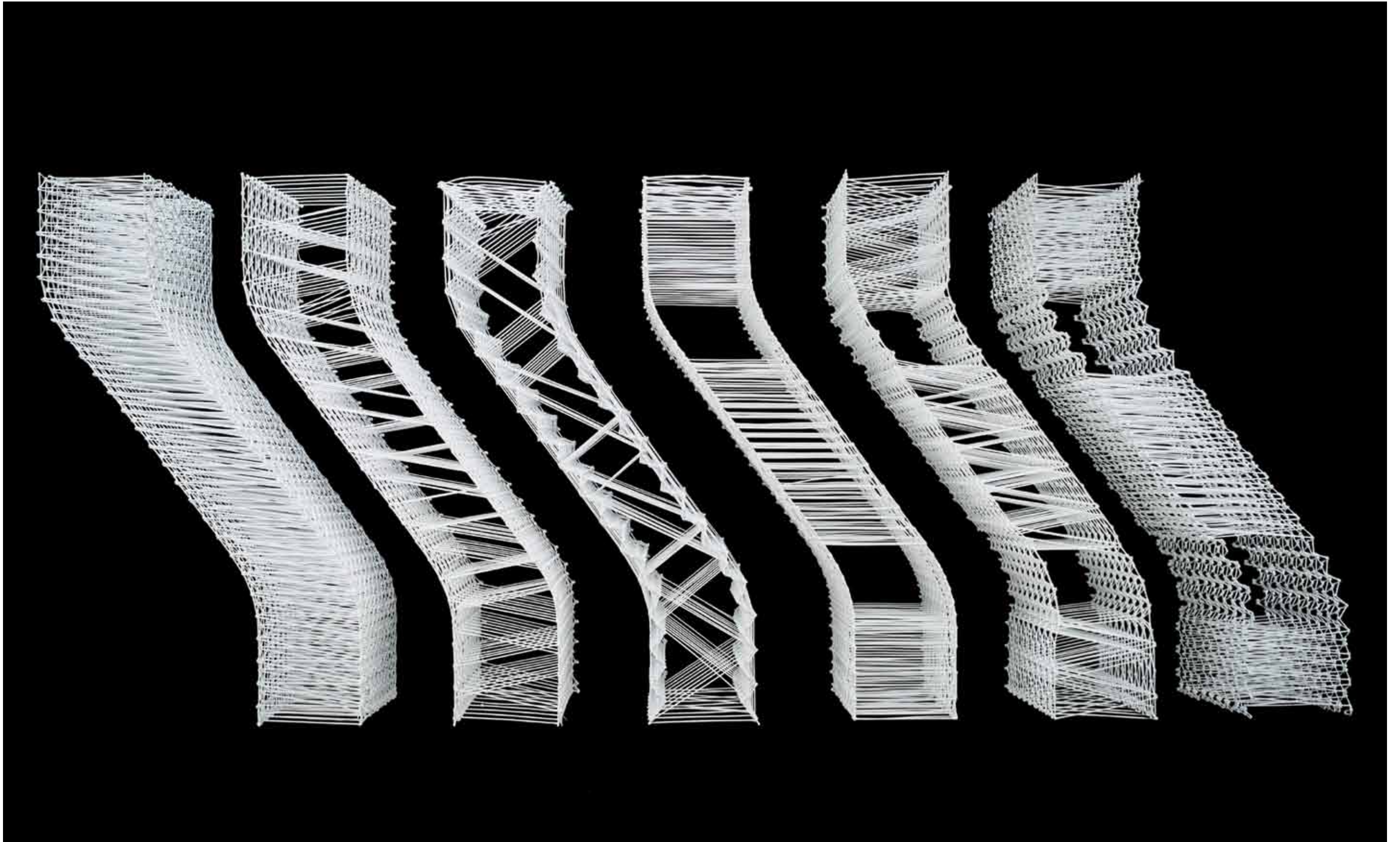

Fig. 15 Top view of all meshes - from left to right: SD, DOD, 2D2D, SOS_Ducts, DD_Ducts, DD_Ducts_Hex. Each mesh uses a different, or a combination of different differentiation strategies

Fig. 19 (left) Concept study for a combined metal bender and welder - among many discussed concepts it was found that the combination of a metal deforming piston with a welding electrode integrated at its tip offered the best trade. Design criteria for the development of a viable combined steel welding and bending tool are potential machine complexity, material process flexibility and the final usability of the steel wire mesh

Fig. 20 (right) Refined electrode design - to process steel wire of varying thicknesses and measure the exact overlap of the wire by closing a circuit the initial electrode had to be refined. It comprises sliding insulators which are pushed away only if two or more wires are overlapping at the tip of the electrode. The pin in the middle (yellow) is only fixed to one side of the electrode and can move linearly into the other half

The next step: Metal meshes

Based on the finding that increasing fabrication speed and strength of a polymer-based process requires extensive material research and presumably has a high energy demand it was decided to go forward with conventional, commercially available metal-wire as the base material for the meshes. Wire displays a variety of advantages in terms of workability; it is naturally strong, can easily be deformed plastically without requiring thermic processes, and can be welded in order to form a strong, force-locking connection. The concept for a metal-based fabrication process focuses on bending an approximately 2 mm wire with a movable welding piston. The piston extends vertically downwards until the two wires touch and a short, intense electrical impulse is discharged, welding together the two wires. A conceptual prototype was developed to demonstrate the basic functionality of this process (Fig. 19). This was followed by a more elaborate version of the tool head, which is currently being tested and refined (Fig. 20, 21, 22). A first sample of a metal mesh has just recently shown the basic functionality of the newly designed tool head (Fig. 23). The intermediate goal will be to reproduce similarly differentiated mesh structures as previously with polymers.

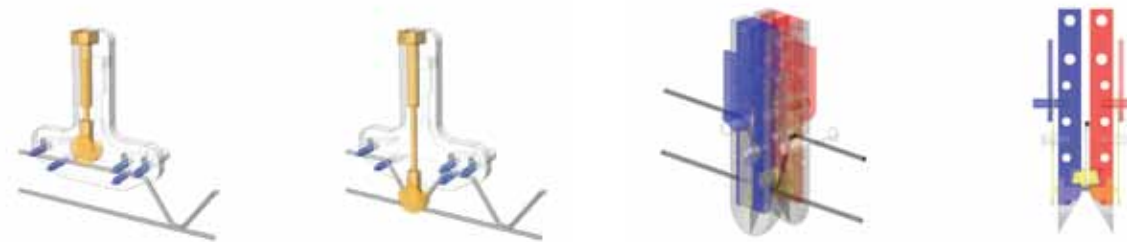

Fig. 21 First wire mesh produced by new robot end-effector - to test the consistency of the bending and feeding mechanism, early tests were carried out in a semi-automatic fashion at which the welding joints were produced manually. This has shown that the mechanical concept of the tool works reliably after swapping aluminium brackets for stainless steel. There is a characteristic asymmetric curvature of the bent wire which is influenced by the radius of the chosen ball bearings and the geometry of the brackets

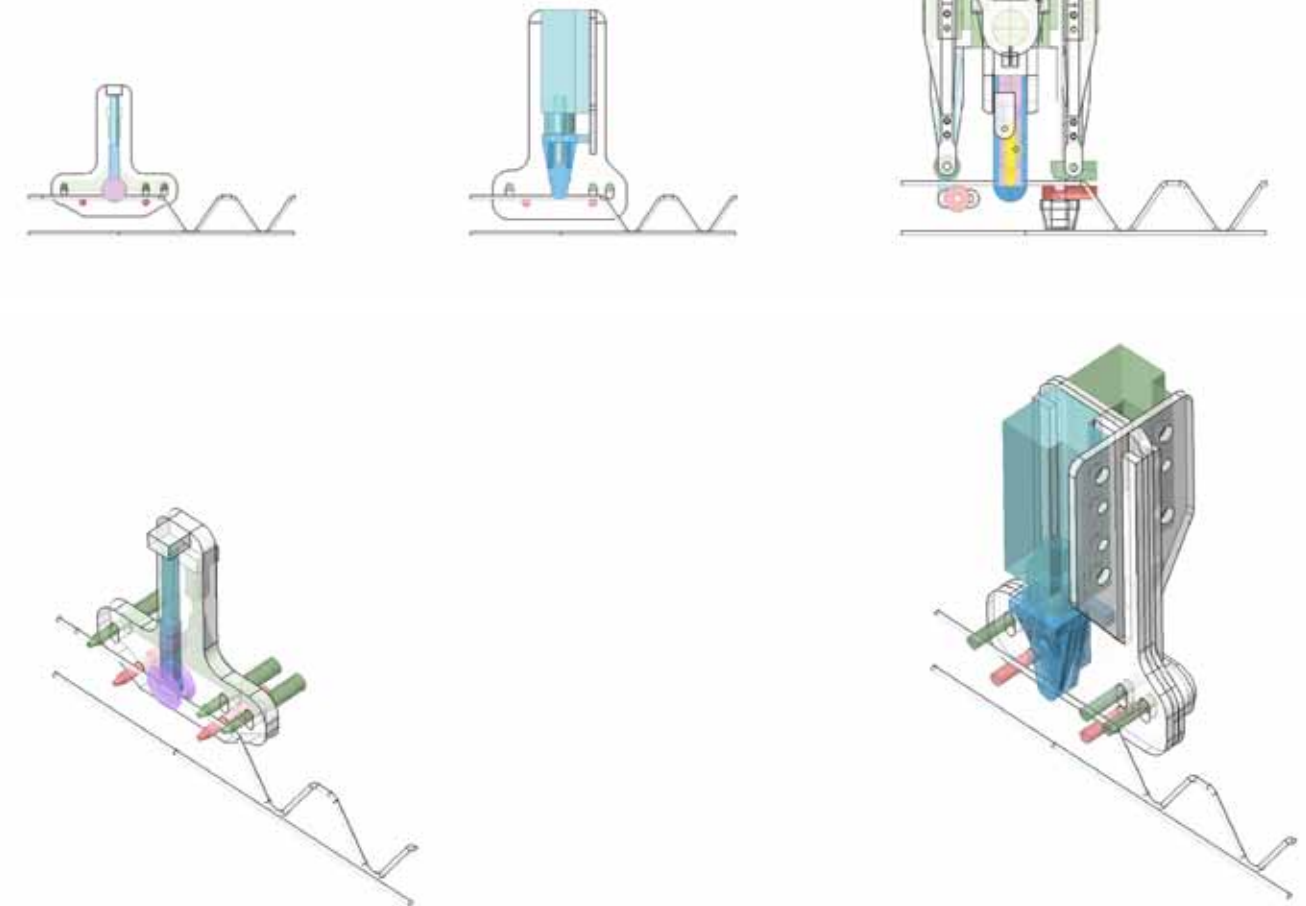
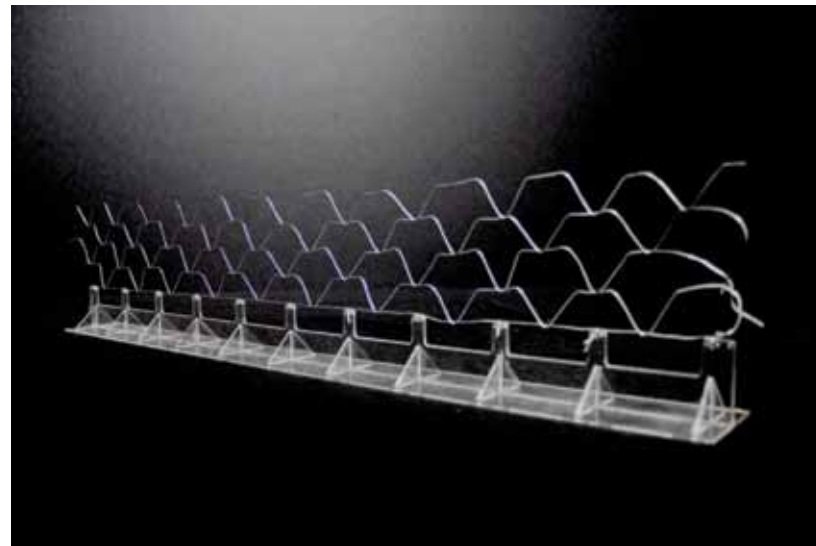

Fig. 22 Metal bender and welder design evolution - despite the aim for low machine complexity, a high number of technical functions and components need to be arranged in a very dense configuration. This offers maximum versatility and enables the tool to fit on a small robot arm. The final tool design had almost the same dimensions as the far less complex polymer extrusion head

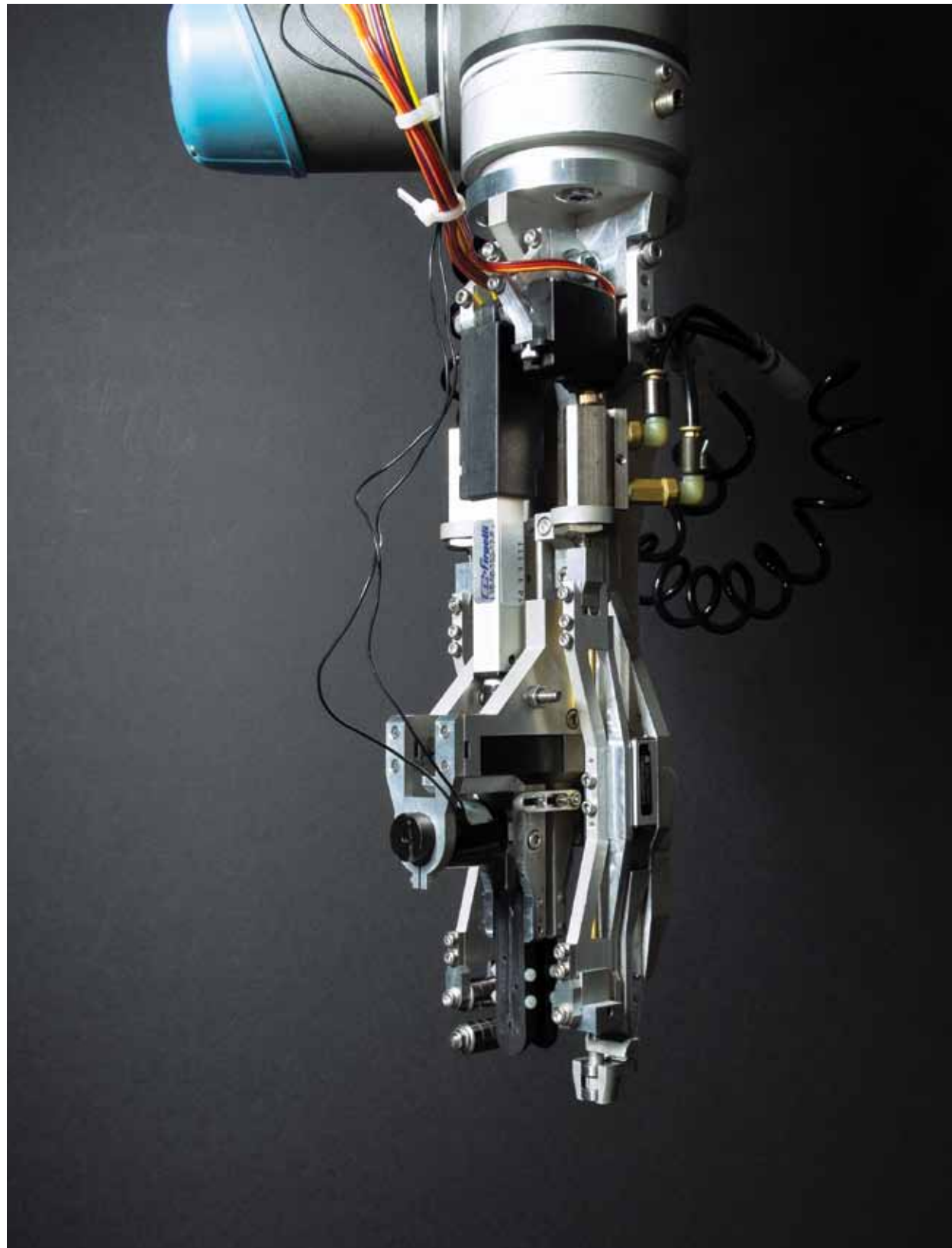

Fig. 23 Finalised prototype for the combined metal bender and welder – after developing the electrode at the very tip, the whole end-effector set-up was designed, including all necessary mechanically and electrically driven components

References

- Daneshgari, P. and Moore, H. (2013) *Industrialization of the Construction Industry*. Flint: MCA Inc.
- Gramazio, F. and Kohler, M. (2008) *Digital Materiality in Architecture*. Basel: Lars Müller Publishers.
- Gramazio, F. and Kohler, M. (eds) (2014) *Made By Robots: Challenging Architecture at a Larger Scale*, Architectural Design No 229, London: Wiley and Sons.
- Hills, D. (2003) *Building Component*. USA, Patent No WO 03/040487 A1.
- Oxman, N. (2013) *Towards a Material Ecology*. San Francisco: Association for Computer Aided Design in Architecture.
- Helm, V. (2012) *Mobile Robotic Fabrication on Construction Sites: DimRob*. Vilamoura: IEEE. p. 4335 - 4341.
- Willman, J., Gramazio, F., Kohler, M. and Langenberg, S. (2012) 'Digital by Material' in Brell-Cokcan S, Braumann, J (eds), *ROBJARCH 2012: Robotic Fabrication in Architecture, Art, and Design*. Vienna: Springer. p. 12-27.
- Willmann, J., Gramazio, F. and Kohler, M. (2014) *The Robotic Touch – How Robots Change Architecture*. Zürich: Park Books.

Endnotes

¹ According to the International Federation of Robotics the number of robots in operation ranges in between 1.1 and 1.4 million globally. <http://www.ifr.org/industrial-robots/statistics/> (accessed 25.07 2013). Despite their abilities, they are mostly performing repetitive tasks.

Credits

This text is an excerpt of papers that were originally published in:

Hack, N., Lauer, W., Langenberg, S., Gramazio, F. and Kohler, M. (2013) 'Overcoming Repetition: Robotic Fabrication Processes at Large Scale', in *International Journal of Architectural Computing IJAC*, 3 (11): p. 286-299.

Hack, N., Lauer, W., Gramazio, F. and Kohler, M. (2013) 'Mesh Mould: Differentiation for Enhanced Performance', in *CAADRIA 2014 - Rethinking Comprehensive Design: Speculative Counterculture*. p. 139-148.

Acknowledgements

We would like to express our gratitude to the entire research group of Gramazio & Kohler at ETH Zürich, especially to Dr Silke Langenberg, Dr Jan Willmann, Volker Helm and Ena Lloret Kristensen, who have always supported the team with the utmost dedication, be it in Singapore or from far away.

Without the initiative and the support of our industry partner, Sika Technology AG, and particularly the personal involvement of Dr Norman Blank this project would have never happened.

On-site Robotic Tiling

Bringing the productivity of robots to construction

Tobias Bonwetsch, Selen Ercan

Employing robotic technology to construction work has the potential to dramatically increase productivity of the building industry, while providing constant and reliable high quality. Tiling work in particular is very labour intensive. It is a slow and manual process, which is prone to errors. In addition, the quality of workmanship decreases as skilled workers become increasingly scarce, a situation that is expected to worsen over the coming decade. This article outlines the development of an on-site robotic tiling machine that can deliver high accuracy at more than double the speed of conventional work. An important aspect is that the machine can be applied as a robotic co-worker that can safely work alongside humans without requiring additional security measures. Thus, it can easily be integrated in the existing construction workflow, lowering the entry barrier for adopting this new technology in the building industry.

Ceramic tiles are a popular finish for floors and walls. They are valued for their durability, traditional quality and richness in appearance. Annually, over 10 billion square metres of ceramic tiles are applied worldwide and the market has seen an annual increase of 10% since 2009.

While the industrial revolution has greatly increased productivity of tile production, the actual process of tiling has seen little innovation and thus remained largely unchanged. Tiling work is very labour-intensive, it is a slow and manual process. Laying tiles in a visually appealing and durable manner is a non-trivial task requiring skilled labour and achieving consistent process quality is a challenge (Wan 2004). In addition, a labour shortage is starting to form in the construction sector as people prefer cleaner, less strenuous and better paid jobs, a situation that is expected to worsen over the coming decade. This labour shortage will first create capacity and/or quality bottlenecks as today's workers retire. Later it will drive up construction costs as new workers will have to be attracted by offering higher wages and better benefits.

Overcoming the limits of manual labour

Tiling essentially blocks an apartment from being worked on by other craftspeople, as the floor may not be walked on until tiling has finished and the adhesive has cured. Hence, it is desirable to complete tiling work as quickly as possible. In order to achieve a visually appealing result, however, tiles have to be laid out in a sequential process, where each tile is aligned to its neighbours. Therefore, tiling work does not scale well and cannot be easily sped up beyond the rate of two people working on the same area, e.g. an apartment floor.

In order to improve productivity, the rate at which tiles are laid needs to be increased. However, without the use of machines, this rate will always be limited by the capability of human workers. Preliminary benchmark tests with our prototype robotic tiling machine indicate that it can increase the rate at which tiles are laid by factor of 2 to 3 compared to a human worker and that manual labour is reduced by as much as 90%. In addition, a robot that needs neither rest nor sleep can in theory work 24 hours a day, 7 days a week, thereby effectively achieving at least 6 times the productivity of a human worker.

Market potential

The research and development of an on-site robotic tiling machine is clearly geared towards value creation for the construction industry. Singapore is chosen as an initial market to test bed the technology and to improve the product.

Assessments have shown that Singapore provides an environment that will be uniquely conducive to initial commercialisation. Reasons are:

First, upcoming shortage of qualified labour, which is a threat, mentioned consistently by local tiling contractors in the interviews we conducted. While at the same time, the targeted high population growth over the next decades demands an unbroken high degree of building activity.

Second, comparatively high wages of tiling workers and BCA's effort to improve construction productivity through financially supporting the adoption of new technologies.¹ This will strengthen the business case for our initial-release product and help us ship actual robots in order to drive down the cost curve, which should then allow us to tackle other markets with less attractive economics.

Third, the Housing Development Board's (HDB) high-quality standards and market power which can push quick adoption rates if we succeed in convincing government stakeholders that supporting our innovation is worthwhile.

Fourth, worker health concerns: Singapore aims to reduce the workplace fatality rate from 2.9 to 1.8 per 100,000 employed persons by 2018 (Ministry of Manpower 2008).

The size of tiling contractors in Singapore varies from large companies that specialise in providing tiling work solely to Singapore's public housing projects (HDB), to smaller shops that are more focused on individual apartment remodelling. Since any kind of automation involves a given amount of setup time, the achievable gains will be more pronounced on large-scale jobs such as HDB housing projects. In addition, ceramic tiles make up 97% of all HDB floor finishes. Therefore, we intend to focus exclusively on HDB tiling in the first stage.

The annual size of the HDB floor tiling market is approximately 5 million square metres per year. Based on our calculations we see an opportunity to sell between 100 and 250 robots for HDB construction in Singapore alone, depending on whether robots will work the same 8 hour shifts as humans currently do, or whether robot shifts are increased to more hours per day. At a minimum 5 years equipment lifetime this results in total cumulated labour savings between SGD 1 million and SGD 2.7 million per robot.

Initial market feedback

As a means of market validation, we conducted over 30 interviews with stakeholders in the Singapore construction industry, ranging from government agencies like HDB and the Building Construction Authority (BCA) to construction companies, especially the large tiling contractors. They stated in unison that there is a lot of room for increasing productivity in the manual tiling process. Already today, they face the problem of recruiting a skilled workforce, which has a direct effect on tiling speed and quality. In general, they favoured adopting automation solutions and would be willing to apply a robotic tiling machine, if it exceeds manual labour in both speed and accuracy.

Two important companies, Jurong Town Corporation (JTC) and Takenaka Corporation, are going to test our current prototype in one of their construction projects. Thereby we will be able to gain valuable feedback for the future development of our product.

Approach

The goal of the research and development is to increase the productivity of tiling work by development of an on-site robotic tiling machine. After placing and starting the robot, the only manual labour remaining will be mixing the tile adhesive, as well as refilling the robot with adhesive and tiles. In order to reduce the complexity of the problem we have broken down the capabilities of the proposed machine into several development steps, each of which builds upon the previous evolution and each of which will provide additional value to the potential customer (Fig. 01). Further

Development Stage	Robot Capabilities
Stage 1	The robot is able to apply adhesive and place all non-cut tiles in a standard floor plan (i.e. the robot covers 80 to 90% of the whole tiling area).
Stage 2	The robot additionally places cut-tiles. Tiles are cut manually; however, the robot's laser scanners facilitate the cutting work by providing exact measurements and cutting instructions.
Stage 3	A companion tile-cutting machine appropriately cuts tiles based on live measurement data provided by the robot.

Fig. 01 Development stages of on-site robotic tiling machine

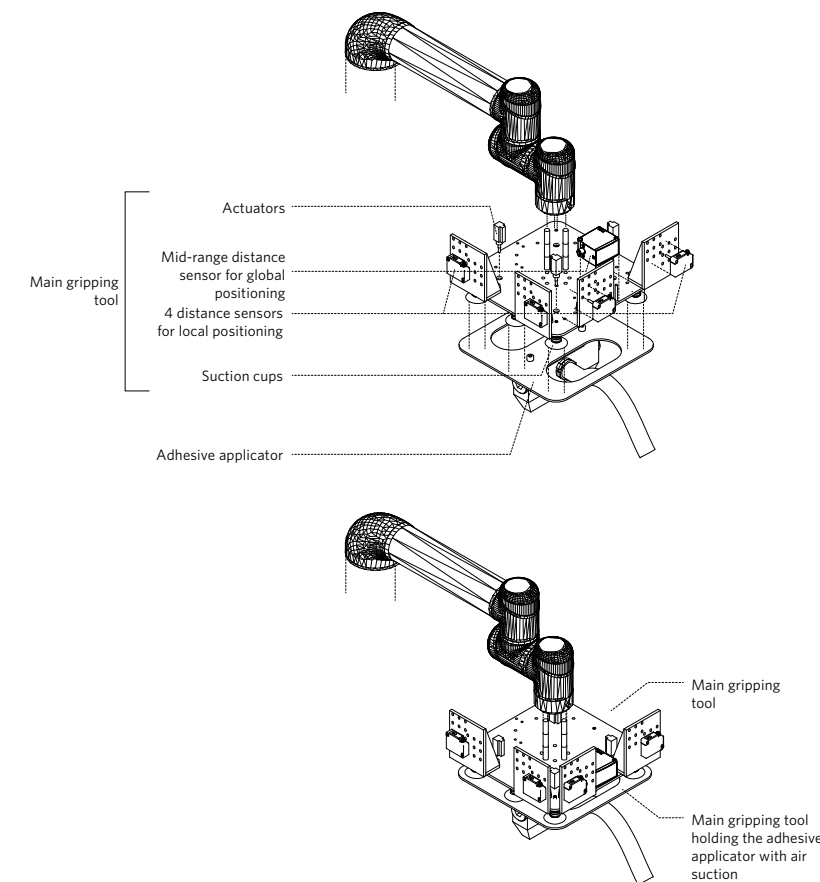

Fig. 02 The custom end-effector in detail - 6th generation

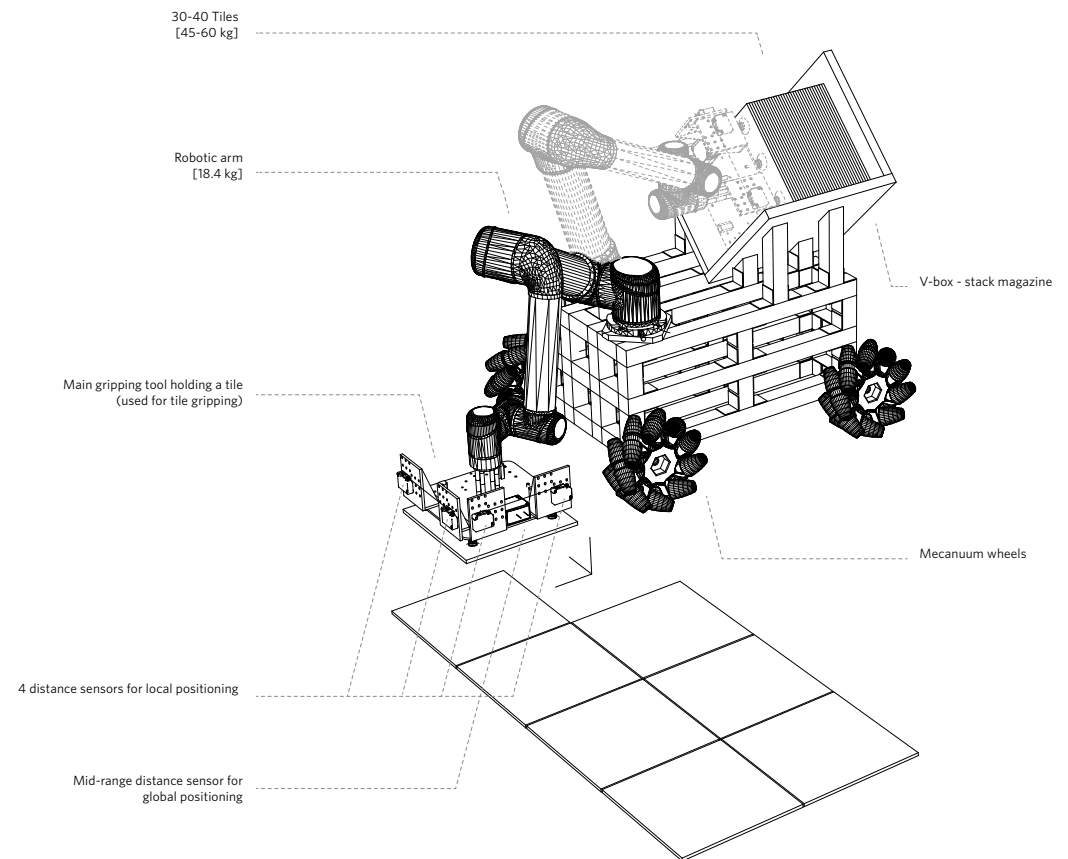

Fig. 03 The custom end-effector

improvements, such as the robot refilling itself with tiles and/or adhesive may be implemented along this development path based on customer feedback once stage 1 has made it to market.

The proposed robotic system consists of a versatile robotic arm that is attached to a mobile platform, which can autonomously move around a room. The robot's arm is fitted with a custom end-effector tool that enables the picking and placing of a tile, as well as handling a specialized nozzle tool to apply adhesive (Fig. 02, 03). Therefore, no time-consuming tool change is necessary between gripping a tile and applying the adhesive. In addition, the end-effector tool is equipped with triangulation-based short- and mid-range distance sensors that are able to work reliably on a construction site such as changing and unfavourable lighting conditions. The sensors allow local (i.e. the neighbouring tiles) and global measurements (i.e. the room) (Fig. 04). In combination with adaptive control software, the end-effector can thus be moved to a precise position regardless of the absolute position of the mobile base (Fig. 05). Hence, there is no absolute precision required in moving the base, which is a great advantage on a construction site where a constant and even floor cannot be guaranteed. Apart from the robotic arm, the mobile base is fitted with a stack magazine carrying tiles and a tank for the adhesive. In our current layout, these need to be refilled manually around every 45 minutes, but may be refilled automatically at

Fig. 04 Schematic drawing of a possible on-site robotic tiling machine



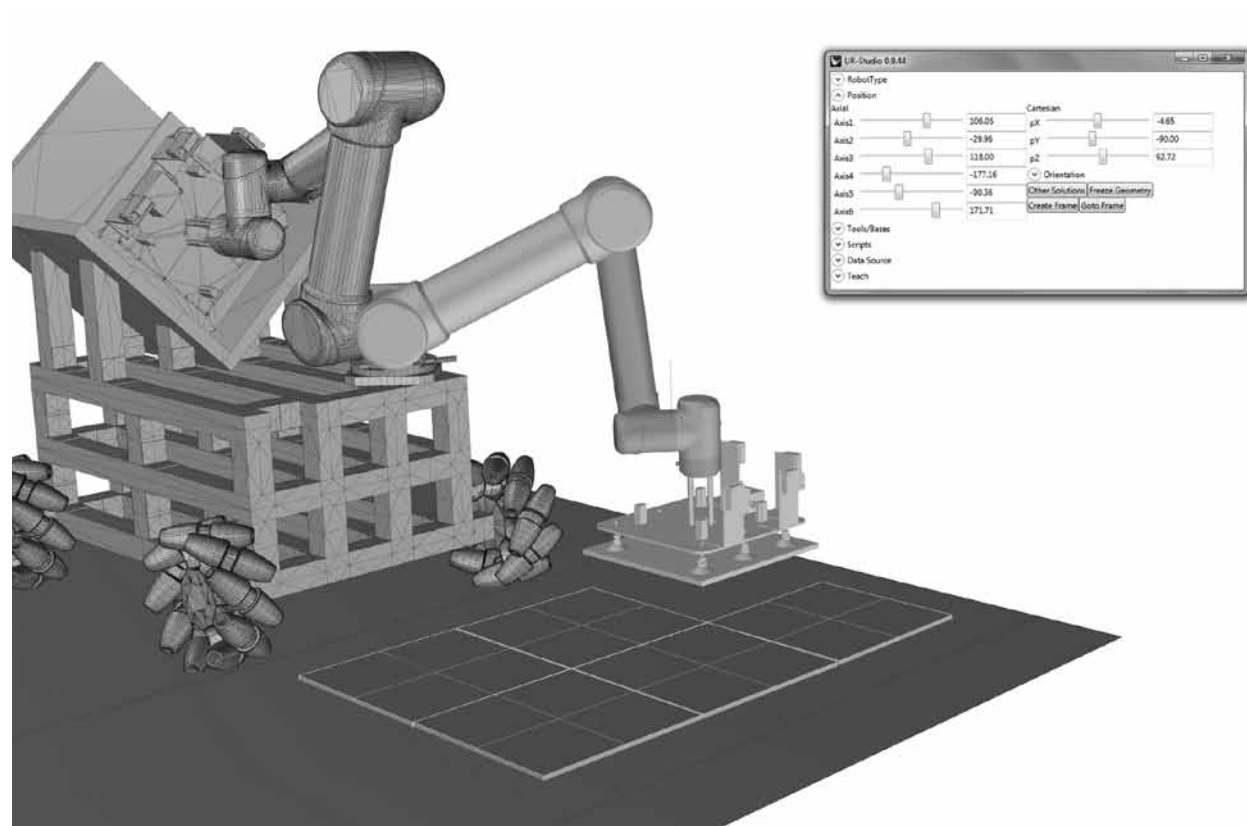

Fig. 05 Adaptive control software and visualisation tool for on-site robotic tiling

a central depot by the robot itself in a later iteration of the product. The system weight and size is designed such that it can operate in small spaces, therefore being able to be applied not only to large spaces, but also to residential units.

A further decisive aspect of our approach is that the robotic system is safe to work alongside humans and the robotic arm applied meets European ISO standard 10218 on safety requirements (ISO 10218, 2011). This is crucial in order to gain easy market access, since no additional safety measures have to be provided for. Our robotic machine can be applied like any other common construction tool.

Finally, in order to set up the robot for more demanding floor designs, we are developing a planning software that reads the CAD design of a building and then allows the user to set out and design a desired floor pattern. In particular, the software will allow fine-tuning the tile grid within each room and thus to specify which tiles have to be cut and by how much. The tile-laying information from the software can then be uploaded directly to the robot for execution.

Current state of research and development

Over a time period of 10 months we have realised a feasibility prototype that can orient itself within the room, scan the position of previously laid tiles and accurately place new tiles on a concrete screed surface with manually pre-applied adhesive (Fig. 06). The current project agenda plans to integrate the adhesive application into the automated process. This



Fig. 06 Current feasibility prototype laying an area of approximately 1 m². The mobile unit was moved manually around 48 times to tile an area of 30 m² with 300 mm x 300 mm tiles, with the robot control system re-localizing itself automatically

involves the design of a special nozzle and extrusion tool that can be operated by the robotic arm (Fig. 07, 08).

A first feasibility prototype was demonstrated at the beginning of May 2014 in a series of live events that involved key political players in Singapore like HDB and BCA, as well as experts and stakeholders of the construction industry including JTC, CapitaLand, etc. and several large- and small-scale contractors and manufacturers as well as some private investors. The event week was finalized with the attendance of Senior Minister of State Lee Yi Shyan – the Ministry of National Development and concurrently the Ministry of Trade and Industry (Fig. 09). The feasibility prototype acts as a proof of concept for applying a mobile robotic system for planning and executing on-site tile work. The essential benchmark for the demonstrator is the ability to compete against manual executed work in regard to quality and time. Here, the current prototype has established that a robotic machine can achieve constant high quality of tile laying and the overall achievable speed will be at least twice as compared to manual labour. The focus in this first phase was on those process steps that are critical to the execution quality of tile work, namely placing the tiles at equal level and achieving an evenly distributed gap size. The prototype robot platform is at present not automated, but moved manually by the means of a hand pallet truck. Since the entire concept rests on the robot arm determining its position in the room and thus not requiring precise movement of its base, the challenge of adding autonomous movement capabilities was given lower priority.



Fig. 07 The mock-up prototype of the automated adhesive applicator, the first generation of a special nozzle and extrusion tool that can be operated by the robotic arm



Fig. 08 Demonstration events took place during the first week of May 2014 with the attendance of Senior Minister of State Lee Yi Shyan, and agencies including HDB and BCA as well as experts and stakeholders of the construction industry such as JTC

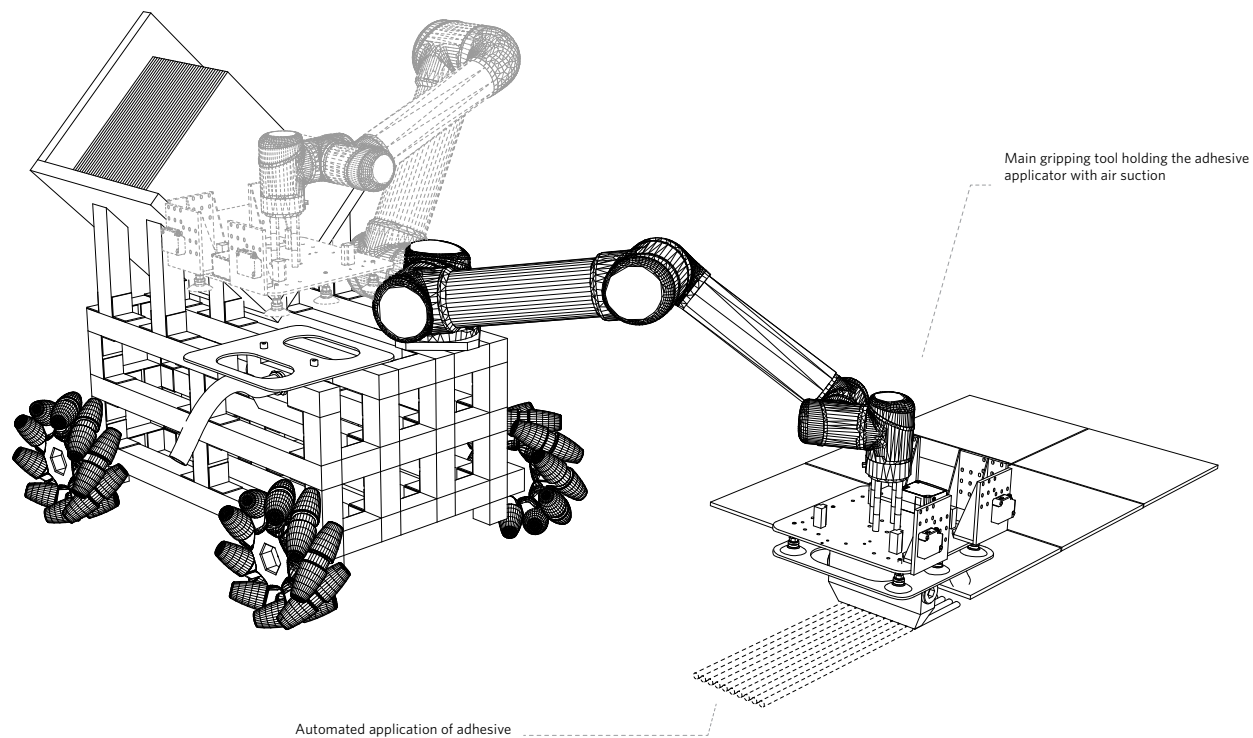

Fig. 09 Drawing showing the automated adhesive application

Technology

The key technology includes a multifunctional gripping tool with attached sensors, an adhesive extrusion tool, as well as a control software that positions the robotic arm according to the acquired sensory data. The following summarises the most important findings.

Tiling quality

Tiling quality can be judged both in terms of visual appearance and in terms of durability. While the first is to a large extent dependent on subjective opinion, the latter has a direct effect on the lifetime of the executed work. No standards exist concerning the visual quality of tiling work. In general, the eye should not detect an inconsistent joint size or a shift from the overall tile grid. The Singapore BCA gives certain quantitative assessment guidelines, although none for gap deviation.² In order to classify the results achieved by our robotic tiling machine, we additionally draw upon guidelines of the Dutch building trust STABU (Fig. 10).³

To date we have performed over 50 experiments laying patches of at least two by three tiles. The tiles of the resulting patch were measured according to their deviation to their ideal grid position. The results yielded an overall gap deviation smaller than 1.4 mm, with an average gap deviation of 0.31 mm (Fig. 11).



Tiling defect	BCA	STABU
 Deviation of neighbouring tiles towards tiling grid.	none	<1.5 mm
 Deflection of a row of tiles towards tiling grid.	none	<3 mm/m
 Deflection of joint width over a length of 2 m.	none	<1.5 mm
 Lippage between two neighbouring tiles.	<1 mm	<1 mm
Evenness of surface.		
	1.2 m	
	2.0 m	<3 mm
	4.0 m	<4 mm
		<7 mm

Fig. 10 Tiling defects

Quality issues concerning durability of a tiled surface can have numerous reasons. Not all are directly related to the tile-laying process, but to choosing the right material combination of tiles and adhesive, or poor grouting.⁴ One crucial aspect determining durability is the bonding quality between the tile and the adhesive. The aim is to achieve a bond strength of 0.15 N/mm². The tensile adhesive strength can only be tested through destructive pull-off tests. Therefore, in Singapore for example, it has become common practice to ensure a maximum contact between tile and adhesive through back buttering. In this process step, the tiler additionally applies adhesive on the backside of the tile before bedding. It is suggested that an adhesive coverage of 90% of the tile underside is sufficient to guarantee an adequate bond strength.⁵ Automating the back-buttering process would be very complex, since the robotic system is only equipped with one arm. Therefore, within our automated process, we substitute the back buttering through introducing vibrating movements during the bedding of the tile. This is a combination of specific movements of the robotic arm and additional vibrating actuators attached on the tile gripping tool (Fig. 12). Tests show that we can thereby achieve the necessary coverage of the tile underside. We also wish to perform tensile adhesive strength tests in the future in order to get reliable data on the resulting bond strength of our process (Fig. 13).

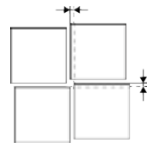
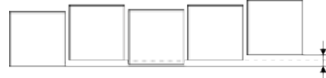
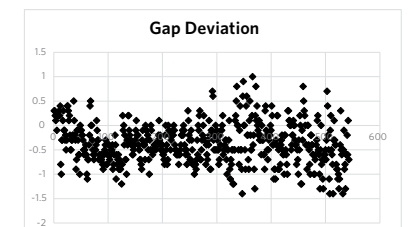
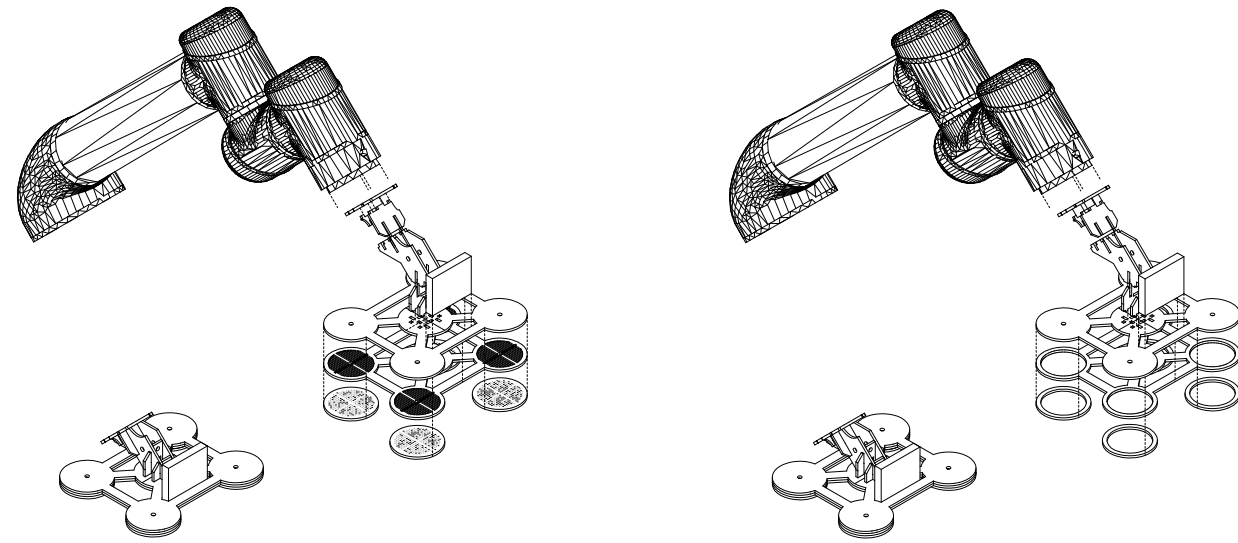
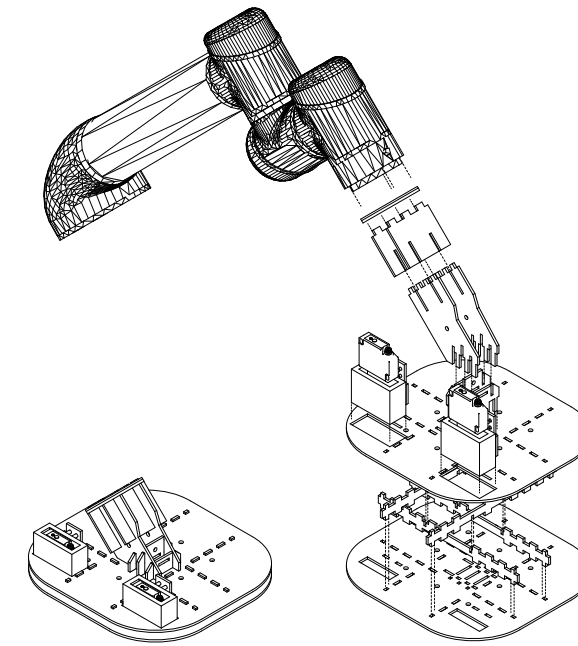

Fig. 11 Distribution of gap deviation on robotically laid tiles

Fig. 12 The evolution of the gripper development and the different generations of the gripping tool



First generation of the vacuum suction main gripping tool, designed and laser cut from acrylic sheets with optimised ducts for air flow for gripping bendable surfaces. The second generation has enlarged ducts for better gripping of stiff and smooth tile surfaces



The third generation with integrated sensors for more precise operations and tile gripping, as well as customised tools

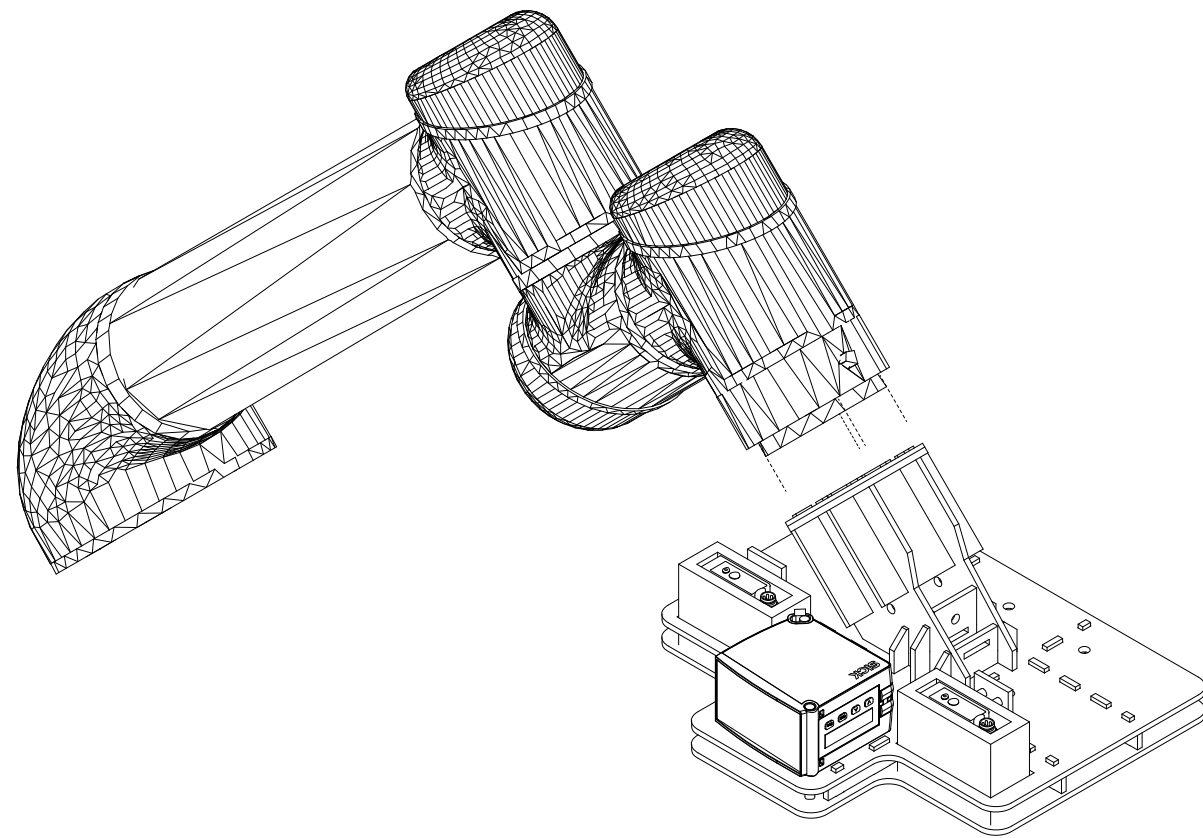

Fourth generation with two short-range distance sensors and one mid-range distance sensor

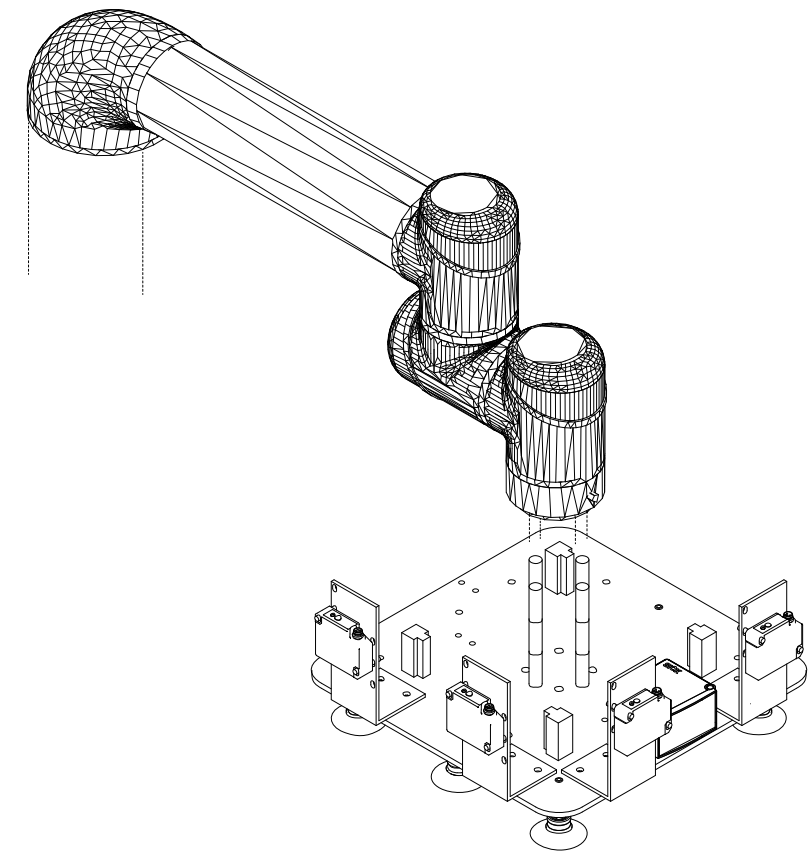

Fifth generation with four short-range distance sensors and one mid-range distance sensor, mounted on a much stiffer aluminium plate



Fig. 13 Various states of the adhesive coverage of tile underside: (from left to right) special bedding movements + vibration, special bedding movements + vibration on an uneven adhesive bed, special bedding movements + vibration on a thinner adhesive bed, no special movements

Productivity

Productivity of tiling work can be calculated as the ratio of the area tiled and the total working time. Tiling work can be broken down into seven distinct process steps: 1) preparation of tiling area, 2) material transport, 3) setting out of tiling area, 4) mixing adhesive, 5) laying of tiles, 6) grouting and 7) cleaning of tiles. Naturally, our automated process does not cover all of the process steps, but we focus on steps 3 and 5. These two are primarily responsible for determining the quality of the executed work and thus require the most skill and experience on the part of the worker. In addition, they take up over 60% of the overall time spent on tiling work.

Step 3, the setting out of the tiling area, determines the final position of the individual tiles on the floor. The aim is to achieve a visually pleasing distribution of tiles and joints. This is of especially high importance if the tiling area reaches across several rooms. This task includes taking measurements of the room and responding to tolerances and differences of the real world dimensions in relation to the initial plans and marking the floor and walls with guide marks. When laying the tiles in step 5, the quality aspects as listed in Fig. 09 have to be considered, as well as achieving a good bonding of the tiles. Fig. 15 compares productivity between manual work and our robotic process of the process steps 3 to 5. Values for the manual process steps are an average from BCA data,⁶ as well as observing the work of 5 different tile workers on site.

The comparison shows that at present the automated process achieves 1.8 times the productivity of manual work. Here it should be noted that increasing the speed of the automated process has not yet been the focus of our development work and that future optimisation will result in further raising productivity. In addition, manual assistance within the automated process (step 5) is reduced to a fraction compared to the manual process. Therefore, one operator can well attend to several tiling robots, which will lead to a further increase in productivity (Fig. 14).

Fig. 14 Screenshot from the simulation software showing the concept of several tiling robots working on-site in parallel, attended by one operator

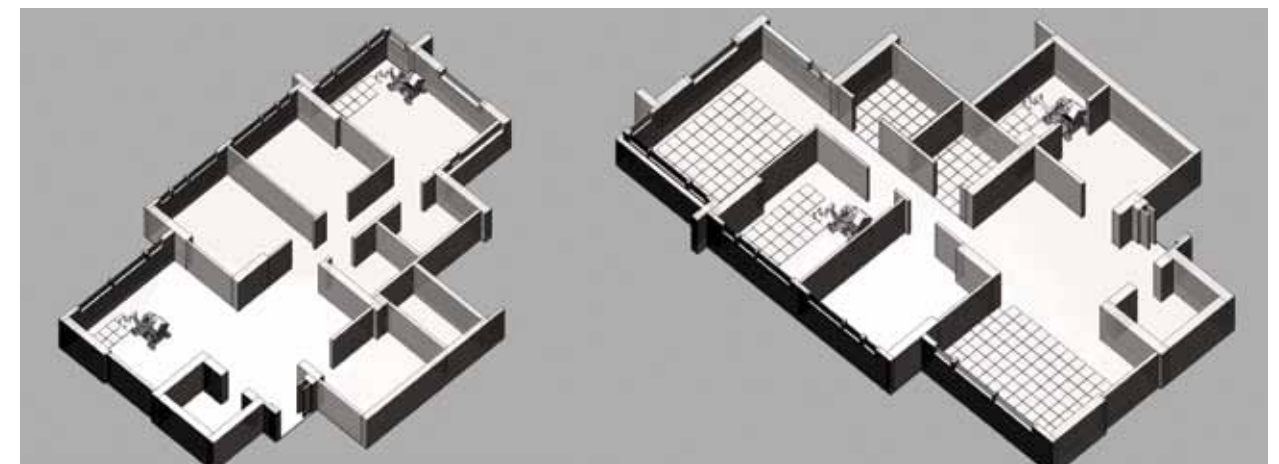

If we compare the complete process of tiling work (steps 1 to 7), employing our robotic tiling machine currently results in an increase of productivity of 1.5 (Fig. 15). Again, this number does not consider the possibility of more than one machine being operated by one person.

Fig. 15 Productivity comparison of overall tiling work

Process step	Manual		Robot-assisted	
	Time min/m2	Percentage	Time min/m2	Percentage
1. Preparation of tiling area	2.6	9.76	2.6	14.27
2. Material transport	1.9	7.23	1.9	10.57
3. Setting out	2.6	9.76	included in 5a	0.00
4. Mixing of tile adhesive	1.3	4.88	included in 5r	0.00
5a. Laying of tiles	10.7	40.28	5.8	26.43
5b. Laying of cut tiles	3.6	13.43	3.6	19.62
6. Grouting/pointing	2.6	9.76	2.6	14.27
7. Cleaning of tiles	1.3	4.88	1.3	7.13
5r. Reloading robot	-	-	1.4	7.71
Total time	26.5	100.00	18.2	100.00
Productivity*	2.26	m2/hour	3.31	m2/hour

*Calculated for development stage 1, where cut tiles are still being laid manually. At a later development stage, the robotic process can cover 63% of the time spent for manual tiling, which will result in a productivity of 4.1m²/hr.

Impact

We envision on-site robotic tiling to be just the start. We are convinced that there is tremendous potential for robotic automation in building construction and that innovation in this field has the potential to completely transform the way we think about construction work and the way we build cities. In a not-too-distant future, the degree of automation in building construction will start to increase significantly by using robotic equipment to partially or fully automate a large part of the work currently performed exclusively by humans. This can bring similar quality and cost improvements to construction as production lines and their associated quality management systems (e.g. Six Sigma and TQM) brought to manufacturing. Future development directions after successfully launching the floor-tiling robot may include extending the robot's capabilities to tile walls, as well as to other domains, such as wall painting.⁷ In addition, while on the one hand adopting robotic systems for construction work can dramatically increase productivity, on the other hand the digital control of formerly manual construction work can facilitate an architecture of high differentiation that can easily adapt to unique requirements.

On a societal level, on-site robotic tiling is a possible solution for a diminishing labour pool, while at the same time raising the qualification level of construction workers. Further, it contributes to a safer and healthier work environment.

While we are concentrating on the specific tasks and skills needed for tiling, we expect certain findings to have a scholarly impact beyond direct market application. Most directly, these apply to the mobile robotic unit operating and locating itself in a semi-known environment as found on a construction site and ways of man-machine interaction common to construction work. As such these can build the foundation for a platform for robotic systems performing a variety of different construction tasks on-site.

References

Ng, Jui Yong, Foo Wen Ng, and Sean Chung (2008) *Occupational Safety and Health Division - Annual Report 2008*. Singapore: Ministry of Manpower.

European Committee for Standardisation (2011) ISO 10218-1:2011 Robots and robotic devices - Safety requirements for industrial robots - Part 1: Robots.

Stock, D. (2012) 'World production and consumption of ceramic tile'. *Tile Today*, 77: 30-37.

Wan, W. C. (2004) *Tiling Failures - A Chronic Problem Re-Visited*. Castellón: Camara Oficial de Comercio, Industria y Navegacion. 'Overcoming Repetition: Robotic fabrication processes at large scale'.

Endnotes

¹ See, Construction Productivity and Capability Fund, online: <http://www.bca.gov.sg/cpcf/cpcf.html> (accessed 12th April 2014).

² BCA, "Good Industry Practice - Tiling"

³ Stichting STABU, STABU-Standaard 2007, „Bestekssystematiek voor de woning- en utiliteitsbouw," Ede, The Netherlands, 2007.

⁴ Grouting is only performed days after the tile adhesive has cured. It is a very fast and easy to perform process. For these reasons, we do not consider it part of the automation process.

⁵ Wan, W. C. (2004). *Tiling Failures - A Chronic Problem Re-Visited*. QUALICER 2004: VIII World Congress on Ceramic Tile Quality, Castellón (Spain), Camara Oficial de Comercio, Industria y Navegacion.

⁶ BCA, "Builders Guide on Measuring Productivity"

⁷ However, wall tiling itself is only a small market, since contrary to widespread floor tiling, only a few designated walls are being tiled.

Acknowledgements

This work is part of a research project at FCL in collaboration with its partner ROB Technologies AG and would have been impossible without the project collaborators Dr Ralph Bärtschi, David Jenny and Matthias Heubi. We would like to thank Willi Viktor Lauer for his collaboration and valuable feedback on the gripper development.

The project was awarded the SMART Innovation Grant in July 2014. The grant is administered by the SMART Innovation Centre and enables faculty and students to accelerate their innovations towards commercialisation.



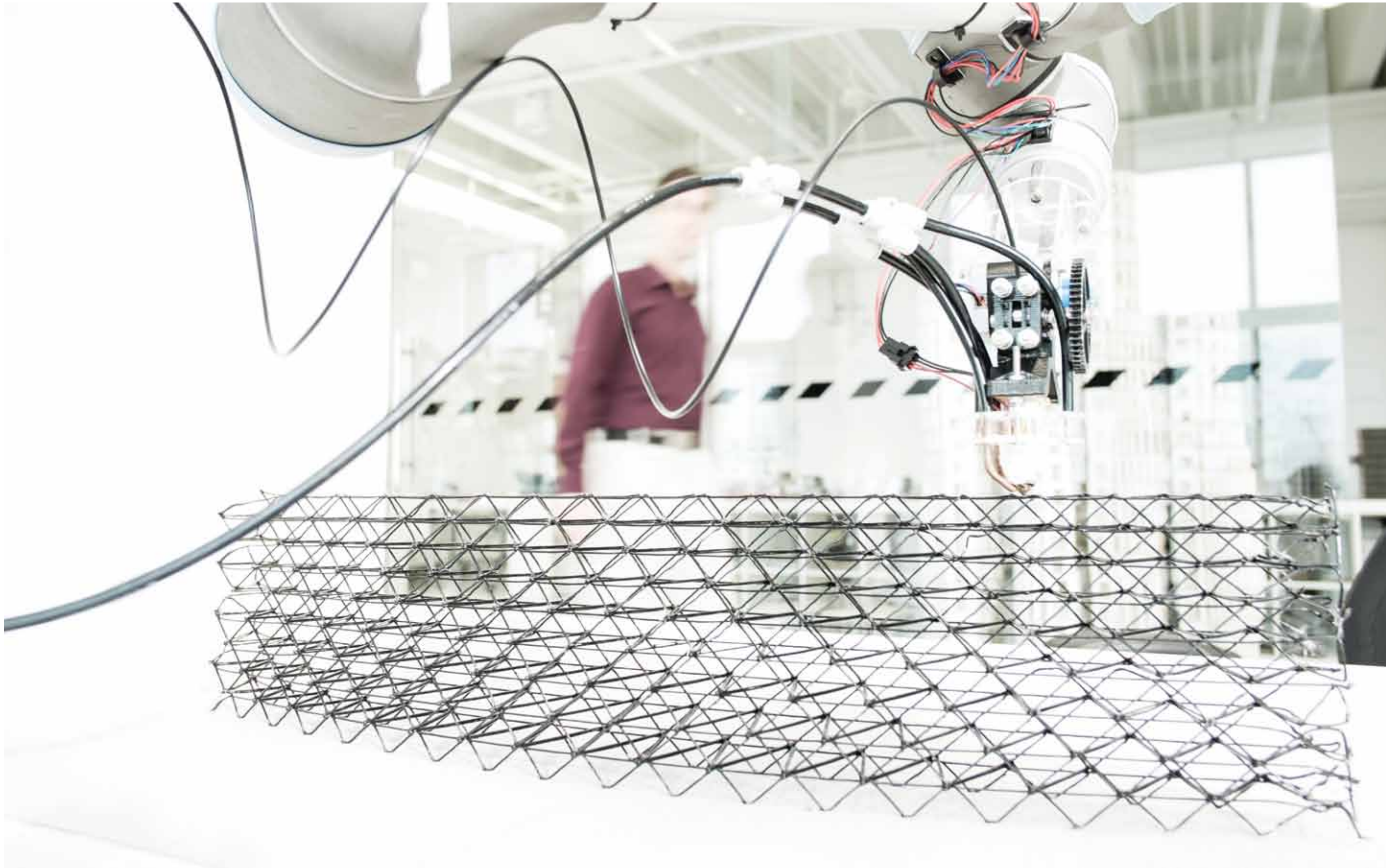









Colophon

Design of Robotic Fabricated High Rises No.03 Research Projects 2011-14

Publisher:

Research Module of
Architecture and Digital Fabrication
Future Cities Laboratory
ETH Singapore SEC Ltd

Editors:

Michael Budig

Layout:

Uta Bogenrieder

Graphical concept:

Lilia Rusterholtz and Uta Bogenrieder

Proofreading:

Text Control AG, Zürich

Print:

First Printers Pte Ltd, Singapore

Images:

Bas Princen: pages 6-7

Callaghan Walsh: cover, pages 20, 22, 44-45

Future Cities Laboratory: pages 23

Vocare Media: pages 12-13, 60, 63, 64-65, 84-85

Campbell McLennan (for Forma-Tech): page 37

All other images © Gramazio & Kohler, Architecture
and Digital Fabrication, ETH Zürich 2011-14

Project funded by:

NATIONAL
RESEARCH
FOUNDATION

(SEC) SINGAPORE-ETH 新加坡-ETH
CENTRE 研究中心

SMART

Industry Partners:



GÜDEL

SIEMENS



R-O-B

Research Module of
Architecture and Digital Fabrication
Gramazio & Kohler
Future Cities Laboratory
Singapore-ETH Centre
www.dfab.arch.ethz.ch
www.futurecities.ethz.ch

Prof. Fabio Gramazio
Prof. Matthias Kohler

Michael Budig (Module Coordinator)
Tobias Bonwetsch
Selen Ercan
Norman Hack
Matthias Heubi
David Jenny
Dr. Silke Langenberg
Willi Lauer
Emiko Lim
Jason Lim
Ena Lloret Kristensen
Raffael Petrovic
Dr. Jan Willmann

© 2014 Future Cities Laboratory
ETH Singapore SEC Ltd
22B Duxton Hill
Singapore 089605



ETH zürich

DARCH

(FCL) FUTURE CITIES LABORATORY 未来城市实验室

(SEC) SINGAPORE-ETH 新加坡-ETH
CENTRE 研究中心

CREATE