

# Chemical Injection & Optimization

**COSASCO**<sup>®</sup> care

Chemical Injection and Corrosion Monitoring go hand in hand and are vital to defend against the devastating effects of corrosion in regards to safety and asset life. Knowing when and how much chemicals should be used for treatment will avoid any uncertainty and is fundamental to any preventative and proactive asset integrity program.

Complete corrosion control is at the heart of Cosasco's offering. With a wide variety of chemical injection access options and chemical delivery methods and devices, Cosasco is your one stop shop for controlling corrosion. Our chemical injection offering coupled with real-time data from our online integrated intrusive and non-intrusive corrosion monitoring chemical inhibitor injection levels can be automatically adjusted based on a fluctuation in corrosion rate in real time. The effects of the inhibitor can be seen almost immediately by the reduction in corrosion rate, assuring accurate dosing every time.

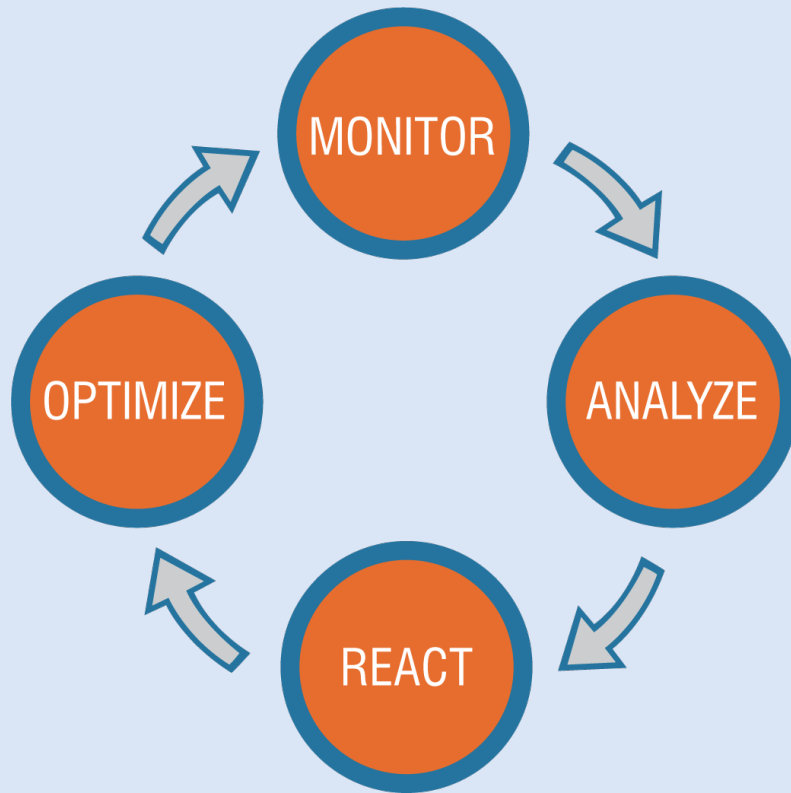

## Injection equals protection

- **Optimize chemical delivery and operational efficiency**
- **Protect and extend asset life**
- **Avoid costly shutdowns**
- **Safely inject a wide variety of chemicals**
- **Control corrosion with accurate dosing**

**Reduction in chemical inhibitor feed starts **saving you money** almost immediately**



## Inject a wide variety of **chemicals**

Cosasco chemical injection equipment may be used with a wide variety of chemicals and across a broad range of industries and applications. From algaecides used in water treatment plants to corrosion inhibitors in oil and gas production our chemical injection devices deliver the right dosage in the most effective means possible. Complete corrosion control gives you peace of mind and reduction in your bottom line.



- Corrosion/Scale Inhibitors
- Biocides
- Boiler Water Chemicals



- Demulsifiers
- Oxygen Scavengers
- Oxidants



- Flocculants
- Neutralizing Agents
- Dewaxers

## Broad range of **applications**



Oil & Gas



Chemical Processing



Pipeline



Heavy Manufacturing



Cooling Systems

## Robust design, bespoke manufacturing

Cosasco chemical injection fittings are manufactured with safety and longevity at the forefront of design and through the whole production process.

Whether it be standard carbon steel or exotic alloys, Cosasco manufactures to the highest quality standards, resulting in a bespoke offering to the latest in stringent safety requirements.

### Unique features

- Robust, machined construction
- Integral check valve (standard)
- Multiple side tee connection options
- Pressures up to 6000 psi
- Meets NACE MR0175 and MR0103



**High Pressure Flanged Chemical Injection Fitting**



Flanged Chemical Injection  
Access Fitting



Secondary Process  
Containment Cover



Flanged Side Tee

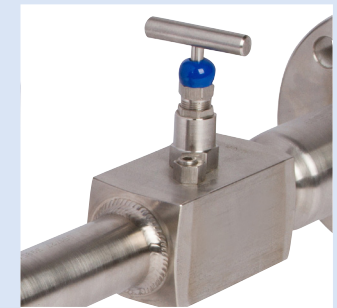

Shut-off Valve

# High pressure injection system

Cosasco offers a wide option of delivery options from standard NPT to robust flanged side tees for chemical injection into high pressure systems. Chemicals can be injected through a variety of side tee connections with custom designs to meet your operating and safety requirements. Cosasco high pressure chemical injection fittings allow safe, controlled, and easy injection under full operating pressure, dramatically reducing downtime.

## Mounting Options

- Flarweld
- Butt weld
- Socket weld
- NPT
- RF & RJ Flanged

## Side Tee Options

- NPT
- RF & RJ Flanged
- Socket weld
- Butt weld

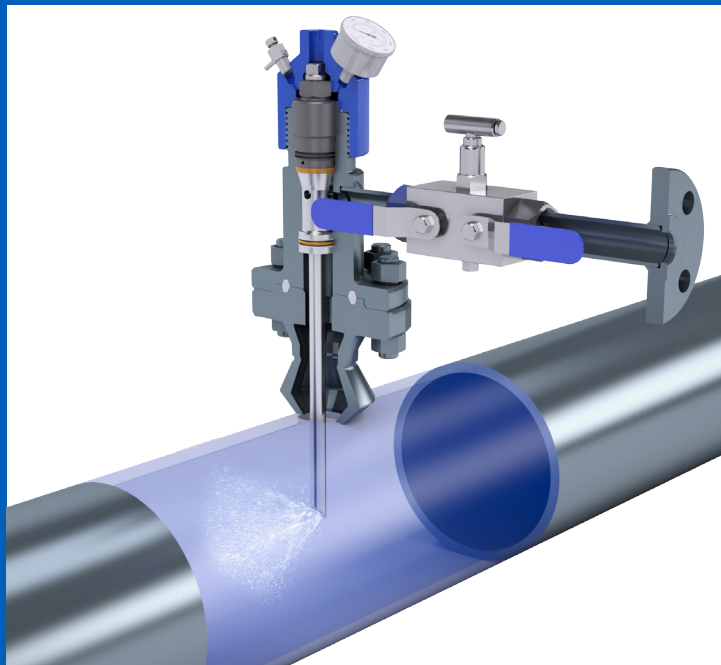

Flanged Chemical Injection Fitting with Socketweld Tee and Double Block & Bleed Valve with Flange Mounting

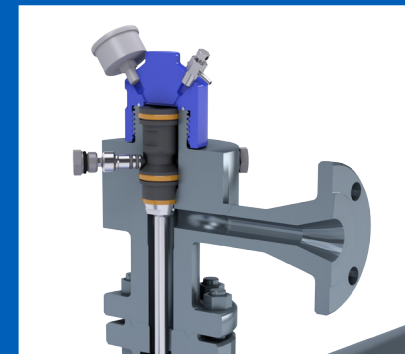
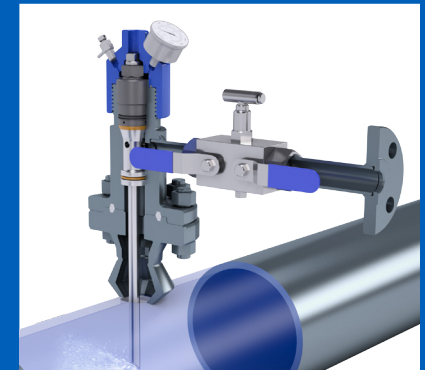



## Low pressure injection system

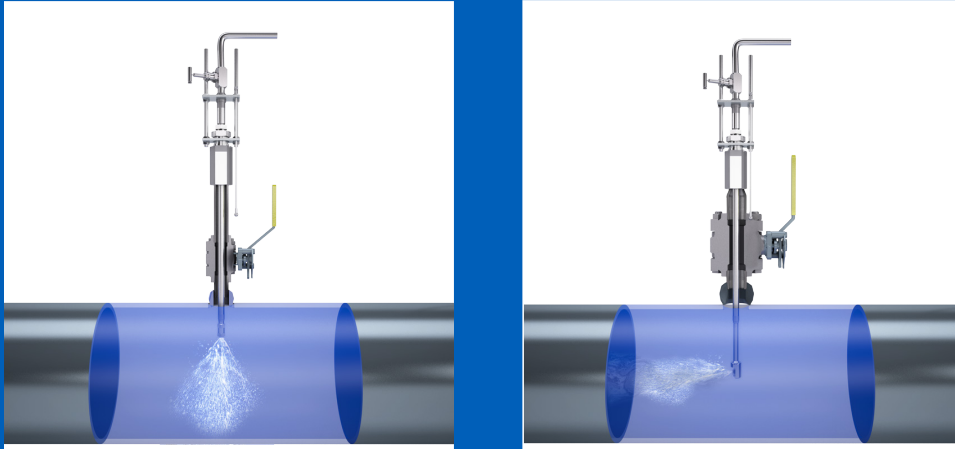

Control chemical dosing and dispersment with Cosasco's retractable chemical injection/sampling tube assemblies. In systems with pressures up to 1500 psi a retractable method of injection is preferred.

The injection/sampling tube can be inserted into the precise location within the process fluid and adjusted if there is a change in the flow pattern or velocities.

- Easily removable for inspection, routine maintenance or insertion in another location
- Adjustable for accurate line positioning
- Wide range of quills and nozzles available

## Fixed injection system

Cosasco Flanged Injection Quills provide a safe and economical means of injecting chemical inhibitors into a pipeline or vessel in both low and high velocity flow lines.

The flanged injection quill can be connected to any type of standard isolating valve, including double isolation. A separate flanged injection component provides safe and efficient means of isolating the line without having to sacrifice either the isolating valve or the flanged quill if one has to be replaced due to damage or malfunction, whereas a single isolating valve/injection component combination would have to be completely replaced.

- All welded design for highest integrity
- For low or high velocity flow lines
- Streamlined designed quill for high velocity applications
- Various materials available

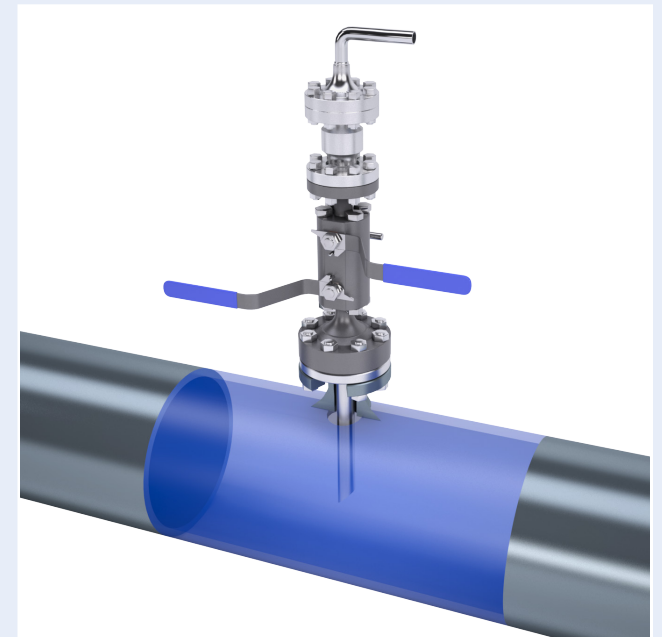

## Chemical injection and optimization

Chemical over-treatment can be expensive especially with corrosion prevention chemicals, and under-treatment can be catastrophic and even more costly. The effects of the inhibitor can be seen almost immediately by the reduction in corrosion rate, assuring accurate dosing every time.

Proper injection and dispersment of chemicals are critical to the integrity of the pipe. If not properly dispersed, some chemicals can be highly corrosive causing significant metal loss to the point of pipeline failure.

With our online integrated systems approach, we can provide you with a total corrosion monitoring and chemical injection package based on your specific application. Comprehensive corrosion data fed into one of our corrosion management servers or DCS, provides continuous data so chemical injection rates can be adjusted in real-time. Our extensive range of chemical injection equipment covers a wide range of applications and seamlessly integrates with our access equipment and tools.



## Chemical injection data logger

Avoid the unnecessary expense of chemical over-treatment and the high risk of under-treatment with Cosasco's RDC-CI Chemical Injection Data Logger.

Quickly discover chemical flow interruptions caused by low tank levels, pump failures, or high-temperature vapor locks. Gain immediate, improved, and economical asset management with the RDC-CI Chemical Injection Data Logger.

### Key benefits of the RDC-CI Chemical Injection Data Logger

- Ensures continuous and cost-effective chemical injection
- Accurate chemical flow monitoring
- User-adjustable graphical analysis software included
- Suitable for a wide variety of applications and chemicals
- Battery operated for quick installation in remote locations
- Easy to use



# Chemical injection portfolio

Chemical Injection Type	Fixed	Retractable	Retrievable
Insertion Method	By Hand	Mechanical (60 Retractor)	Mechanical (RBS/RBSA/RSL Retriever)
Shut-down Required for Insertion/Retrieval	Yes	No	No
Temperature Rating	+500°F (+260°C)	+500°F (+260°C)	-15°F (-26°C) to 400°F (+204°C)
Maximum Operating Pressure	High Pressure (up to 6000 psi)	Low Pressure (up to 1500 psi)	High Pressure (up to 6000 psi)
Mounting Option	Standard ANSI/API Flanges	1"-1 1/2" Full Port Ball Valve	Cosasco Access Fitting
Meets NACE MR0175 and MR0103	Yes	Yes	Yes
Meets CRN and PED	No	No	Yes
Sampling Option	Yes	Yes	Yes
Replaceable Injection Quill/ Nozzle	No	Yes	Yes
Maintenance Under Operating Pressure (ie. clogged nozzle)	No	Yes	Yes



## Regional offices

### Santa Fe Springs

11841 Smith Avenue, Santa Fe Springs,  
CA 90670 USA  
Phone: +1 (800) 635-6898  
Phone: +1 (562) 949-0123  
Fax: +1 (562) 949-3065

### Middle East

PO Box 8186, SAIF Zone  
Sharjah, UAE  
Phone: 00971 6 5579630  
Fax: 00971 6 5579631

### Australia

5/17 Caloundra Road, Clarkson,  
Perth, WA 6030 Australia  
Phone: +61 8 9207 2578  
Fax: +61 8 6316 1417

### United Kingdom

Units 1 & 2, Technology Centre  
Aberdeen Science & Energy Park  
Claymore Drive, Bridge of Don  
Aberdeen, AB23 8GD, UK  
Phone: +44 (0) 1224 825500  
Fax: +44 (0) 1224 825505

### Singapore

51 Goldhill Plaza  
#14-07/08  
Singapore 308900  
Phone: +65 6255 2822  
Fax: +65 6255 1191

### Houston

Northgreen Business Park  
1404 N. Sam Houston Parkway E, Suite 130  
Houston, TX 77032  
Phone: +1 (281) 219-8200  
Fax: +1 (281) 219-7745

### China

Room 1502, Tianchen Plaza  
Yi-12 Chaoyangmen North Street  
Dongcheng District, Beijing, P.R.China 100020  
Phone: +86-10-6551-6135

Contact your local Cosasco office for more details and pricing at [sales@cosasco.com](mailto:sales@cosasco.com) or visit [www.cosasco.com](http://www.cosasco.com) for more product information.

**COSASCO**<sup>®</sup>