

CORRATER® E-9020

DIGITAL TRANSMITTER

Reference Manual



CORRATER® and MICROCOR® are registered trademarks of Rohrback Cosasco Systems, Inc.

No part of this manual may be reproduced or transmitted in any form or by any means, electronic or mechanical, including photocopying and recording, for any purpose, without the express written permission of Rohrback Cosasco Systems, Inc.

Table of Contents

Chapter 1 Introduction	1
Chapter 2 Specification	3
Chapter 3 Installation	5
Chapter 4 Operation	15
Appendix A ATEX Certifications	17
Appendix B Troubleshooting Procedure	21
Appendix C Corrater Theory of Operation	23

Introduction

CHAPTER 1

NOTE: Your Corratel® E-9020 Transmitter was carefully tested, inspected and packaged prior to shipment. Before unpacking the instruments, please inspect the packaged materials for shipping damage and retain damaged packaged materials to support any claim against your freight carrier should this become necessary.

The Corratel digital transmitter Model E-9020 is based on the same technology as the high-resolution Microcor® digital transmitter. The resolution of this new transmitter far out-performs previous instruments. Its resolution is 0.1% of ranges 0-1%, 1-10%, and 10-100% of full scale. The E-9020 has a corrosion rate range of 0 to 200 mpy and imbalance range of 0 to 200 pitting units.

The E-9020 has a patented high frequency measurement on two electrodes for compensation of solution resistance that provides the highest accuracy and widest range of operation. It is designed to operate on the same communication lines as Microcor and is ideal for on-line corrosion monitoring of water systems in electrically hazardous areas.



Figure 1 Model E-9020 Corratel Transmitter

The transmitter must be relatively close-coupled to the probe in order to achieve this improved performance. This is achieved by direct connection to the probe through short probe-connecting adapter, or in the case of some retractable probes through a cable of no more than 2 meters (6 feet) length.

A typical installation of a Corratel transmitter is on a high pressure access fitting with a flexible conduit connection cable. The transmitter and the connectors that attach to it are explosion-proof (flame-proof).

Warning: Power must be removed before disconnecting either connector on the transmitter if explosive gases are present

The Corratel transmitter may be used for continuous on-line monitoring systems with or without Microcor transmitters. The 24 VDC power supply and the RS 485 communications in an online system allow multi-drop connections between the central corrosion monitoring computer and all of the transmitters, which minimizes cabling costs. Each transmitter has internal DIP switches to set the Identification Number or Address of the transmitter from 0 to 31 for communications over the two-wire RS 485 bus.

Specification

CHAPTER 2

Corrater® Transmitter Model E-9020:

- Enclosure NEMA 7 and IP 66/ NEMA 4X
- Weight 3.5 lbs (1.6 Kg)
- Dimensions 4.5" (115mm) Diameter by 4.25" (108 mm) High including connectors
- Power supply 10-32 VDC at the transmitter
- Current consumption at 24VDC typical 17 mA
- Communication RS 485 two-wire 2400 Baud, 8 data bits, 1 stop bit, and no parity if applicable
- Proprietary communications protocol (see Appendix B for details)
- RS 485 addresses 0 to 31
- Measurement Ranges:

Corrosion Rate:	0 to 200 mpy 0 - 5,000 $\mu\text{m}/\text{y}$ 0 - 5 mm/y
-----------------	--

Imbalance (Pitting Index):	0 to 200 pitting units
----------------------------	------------------------

Potential Measurement:	0 to 2 volts
Potential Input Impedance	>20 Mohms

Galvanic/Current Measurement	0 to 500 μA
------------------------------	------------------------

- Resolution: 0.1% of ranges 0-1%, 1-10%, 10%-100% of full scale

- Operating Range:

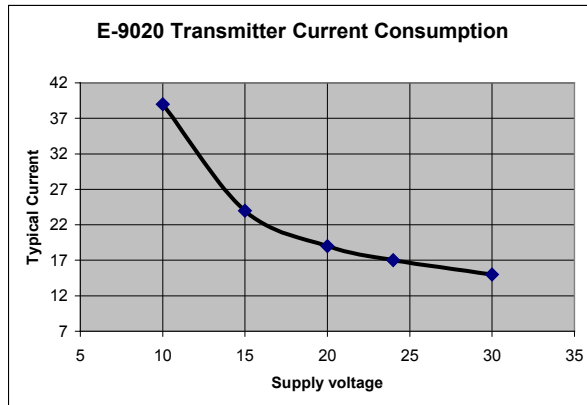

- Multiplier Range: 0.2 to 2.99
- Probe Compatibility:
2 or 3 Electrode CORRATER® probe
- Measurement Cycle Time:
5, 10, 15, 20 minutes selectable
- Isolation:

Measurement circuit to RS 485	>20 Mohms
Measurement circuit to ground	>20 Mohms
- Ambient temperature range -40C to +70C (-40F to 158F)
- Hazardous area Certifications:

ATEX:	Class 1 Zone 1, EEx d IIC T6
UL:	Class 1 Zone 1, AEx d IIC T6
CSA:	Class 1 Zone 1, Ex d IIC T6
	at $T_{amb} = -40C$ to $+70C$

Installation

CHAPTER 3

The E-9020 is intended to be used with any standard 2-electrode CORRATER® probes. Three electrode probes can also be used, but for simplicity and economy, it is recommended that 2-electrode probes be used. Probes with replaceable cylindrical electrodes are generally referred to as “standard” probes, and probes with disc electrodes are referred to as “flush” probes because the electrodes are flush with the end surface of the probe. The probes are available in many designs including fixed, adjustable, retractable and retrievable mounting configurations. Also, probe electrodes are available in many element and alloy materials. The material selected should closely match the material of construction of the pipe or vessel for which corrosion information is desired.

Probes should be installed where corrosion is most likely to be greatest so that readings will truly represent the most aggressive system corrosion rates. Preferably, they should be located where the liquid flow velocity past the electrode exceeds 1 foot per second (0.3 m/sec.) if it is required to measure corrosion rates representative of a flowing environment. Alignment of the electrodes relative to the direction of process flow is important to obtain reliable corrosion rate measurements. Proper alignment is with the imaginary line connecting the center lines of the two electrodes perpendicular to the direction of the process flow. Refer to Figure 1. With this orientation, one electrode does not “shade” the other electrode, and both are subject to nearly the same corrosive environment. If a probe is installed in an elbow fitting, where flow changes direction, position the probe so that the electrodes “face” the oncoming flow. Refer to Figure 2.

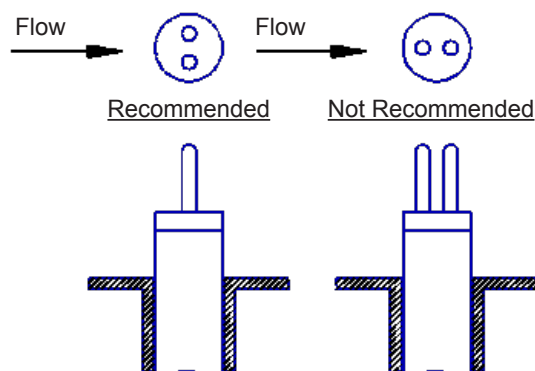

Figure 1 Probe Orientation Relative to Flow

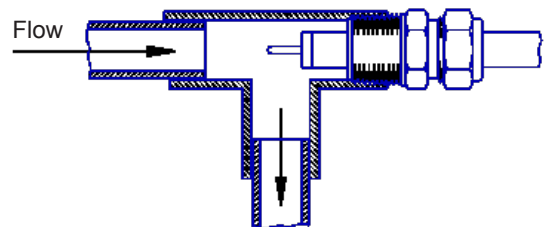

Figure 2 Probe Orientation at a Tee Fitting



Figure 3 Model 7012 and 6112 Probes

Transmitter Enclosure

The Corratel transmitter enclosure is explosion-proof (flame-proof), and is sealed with an O-ring so as to be gas-tight when fully tightened.

Warning: It is very important to make sure that the transmitter cover is fully tightened down on to the O-ring seal, to avoid in-leakage of water or moist air that may subsequently cause condensation. Water or condensation is likely to cause malfunction of the transmitter and even corrosion of the electronics. A corrosion inhibitor pad is included inside the transmitter for added protection.

The transmitter cover can be tightened, with the aid of a 2" center by 1/4" pin spanner wrench on the base of the unit and by hand or with a 3/8" square bar or similar on the cover. See Figure 4. The cover of the transmitter can be locked in place with the 1/16" Allen screw. See Figure 5. This is a requirement of the explosionproof (flameproof) enclosure to prevent accidental loosening of the cover. When connecting the transmitter to a probe and power/communications cables in a hazardous area, explosionproof (flameproof) connectors are used as shown in Figure 6. Take care when making these connections not to damage the sealing O rings. A small amount of white grease or silicone grease should be used to lubricate the O rings to assist assembly. Make sure that the connector nuts are fully tightened over the O rings, and that the Allen screws are then locked to prevent loosening. The connections may only be made and unmade in a hazardous area with the power shut off to the system. Take care when disconnecting a cable or probe to make sure that the Allen locking screw has been loosened first.



Figure 4 Spanner Wrench



Figure 5 Locking Allen Screw

The transmitter connects to the probe directly via the probe-connecting adapter. If necessary, a special extension cable of no more than 6 feet (2 meters) may be used between the probe and the transmitter. This may be required on some retractable probe installations where the transmitter on the end of the probe would be subject to too much vibration or too high a temperature.

The spanner wrench, Allen Key, and manual CD are included in the Installation Kit.

Transmitter Connections

The System connections to the transmitter are as follows:

Connector	Color	Pairs	Description
A	Black	Pair	0 VDC Supply
B	Red		24 VDC Supply
C	Green	Pair	RS 485 - Tx+ (B)
D	White or Black		RS 485 - Tx- (A)

When multiple transmitters are used on the same RS 485 line, each transmitter must be set to a different electronic address. By the RS 485 standard, up to 32 transmitter/receivers may be used on one RS 485 line. The maximum line length is 4000 feet (1200 meters). For lengths greater than 4000 ft, a repeater must be used. For typical systems with more than 32 transmitters, multiple communication ports are used on the corrosion computer with no more than 32 transmitters on any one com port.

The requirements of the standards for use of the Corratex transmitter under its explosion-proof rating (flame-proof) call for the transmitter to grounded (earthed) or bonded to ground. When the transmitter is connected directly to a probe, this bonding is accomplished through the probe body. To ensure good bonding, an 14 to 18 swg grounding wire can be attached to the transmitter at the grounding stud provided and connected to ground (earth)

Setting Addresses for RS 485 Multi-drop

The transmitters are delivered with addresses already set. This address is marked on the outside of the transmitter as the I/N or Identification Number. These addresses can be used directly if the system is less than 32 transmitters without making any changes. If it is an add-on to an existing system, then the number may have to be changed, in order to avoid any address conflicts with an existing transmitter on the same line. If there are more than 32 transmitters on the system, then no more than 32 can be used on any one communication line.

The DIP switch for setting the address and other parameters is on the top circuit board of the transmitter (see figure 6)

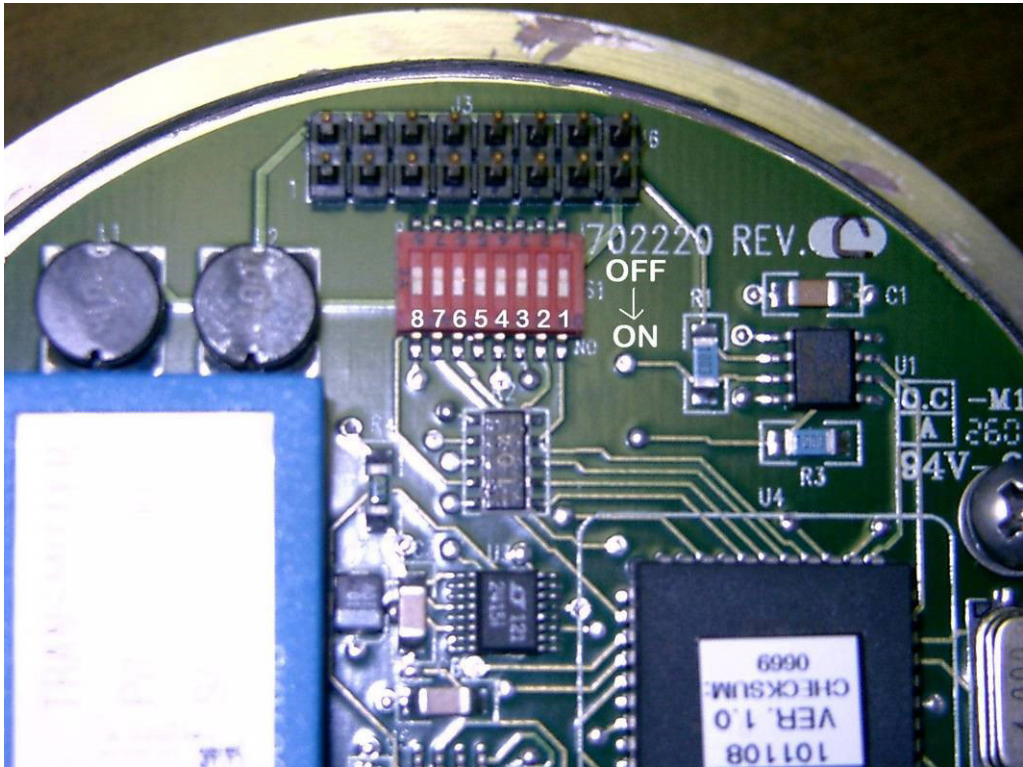

Figure 6 DIP Switches

The Transmitter addresses are set by DIP switches 1 to 5

DIP	1	2	3	4	5	1	2	3	4	5	1	2	3	4	5	1	2	3	4	5	
Address	0					8					16					24					
ON	*	*	*	*	*	*	*	*		*	*	*	*	*		*	*	*			
OFF									*						*				*	*	
Address	1					9					17					25					
ON		*	*	*	*		*	*		*		*	*	*			*	*			
OFF	*					*			*		*				*	*			*	*	
Address	2					10					18					26					
ON	*		*	*	*	*		*		*	*		*	*		*		*			
OFF		*					*		*			*			*		*		*	*	
Address	3					11					19					27					
ON			*	*	*			*		*			*	*				*			
OFF	*	*				*	*		*		*	*			*	*	*		*	*	
Address	4					12					20					28					
ON	*	*		*	*	*	*			*	*	*		*		*	*				
OFF			*					*	*				*		*			*	*	*	
Address	5					13					21					29					
ON		*		*	*		*			*		*		*			*				
OFF	*		*			*		*	*		*		*		*	*		*	*	*	
Address	6					14					22					30					
ON	*			*	*	*				*	*			*		*					
OFF		*	*				*	*	*			*	*		*		*	*	*	*	
Address	7					15					23					31					
ON				*	*					*				*							
OFF	*	*	*			*	*	*	*		*	*	*		*	*	*	*	*	*	

The DIP switches 6 and 7 may be OFF or ON on this model.

System Wiring Requirements

Care is required when installing cabling for connection of an on-line multi-drop system, especially on the 24VDC supply lines to ensure that there is sufficient voltage at each transmitter to drive the electronics. A two pair individually shielded cable is recommended. The gauge of the wire depends on the number of transmitters and the maximum cable length. We do not recommend cables of less than 22 swg. The following calculations are based on a nominal 24VDC supply at the source. The Corratel transmitter and connectors are explosion-proof (flame-proof) and meet hazardous area requirements. Flexible or rigid conduits are required to meet North American hazardous area requirements. Flexible conduits are also frequently preferred in order to provide physical protection to the cables, such as shown in figure 2. If cabling is sized correctly for the 24 VDC supply, it will also be more than adequate for the RS 485 communications.

Maximum Number of Transmitters with 24 VDC Supply					
Wire Gauge		Cable Length			
		300 m	600 m	900 m	1200 m
AWG	Dia (in)	1000 ft	2000 ft	3000 ft	4000 ft
10	0.120	32	32	32	32
12	0.096	32	32	32	27
14	0.076	32	32	22	17
16	0.060	32	21	14	10
18	0.048	27	13	9	6
20		17	8	5	4
22		10	5	3	2

The connection arrangement for multi-drop wiring is shown in figure 7.

Warning: RS 485 is a serial, not parallel, connection system. Only short connections are permitted between the RS 485 bus and the transmitter (not more than 50 feet). Splitting the RS 485 bus into two or more spurs of more than 50 feet is not permitted without an RS 485 repeater module.

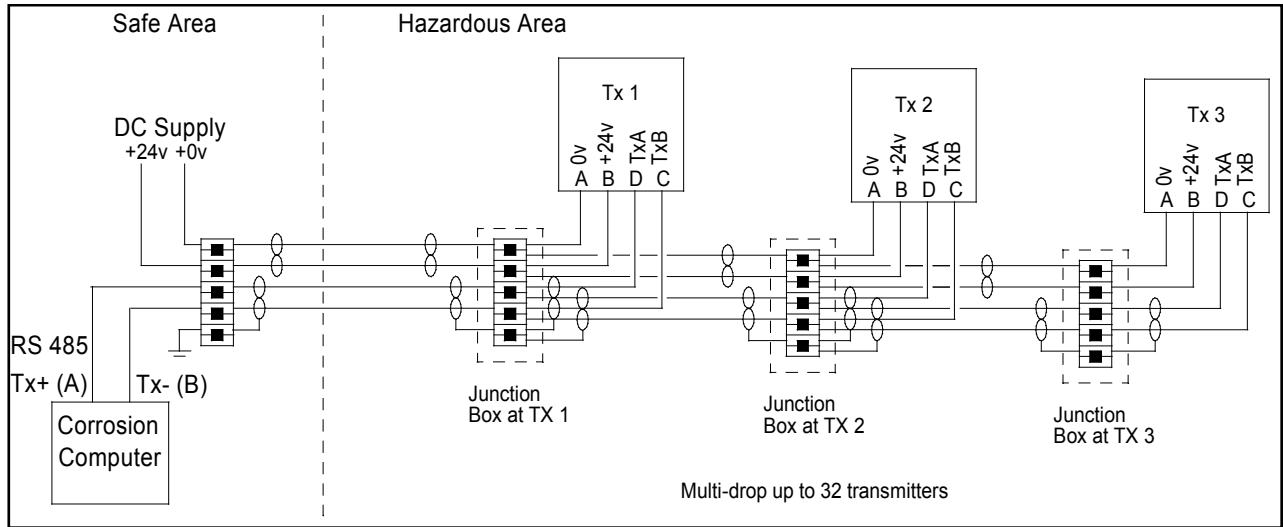

Figure 7 Multi-drop wiring

Conventions of designating Tx+ and Tx-, or A and B for RS 485, commonly vary with different manufacturers. The conventions used here correspond with the EIA standard. Under idle conditions, terminal B is positive with respect to terminal A. The corrosion computer can use a plug-in isolating RS 485 card on a desktop or industrial computer, or an external RS 232 to RS 485 converter (preferably isolating), such as the RCS model MA-1000, on a portable computer (see figure 8).

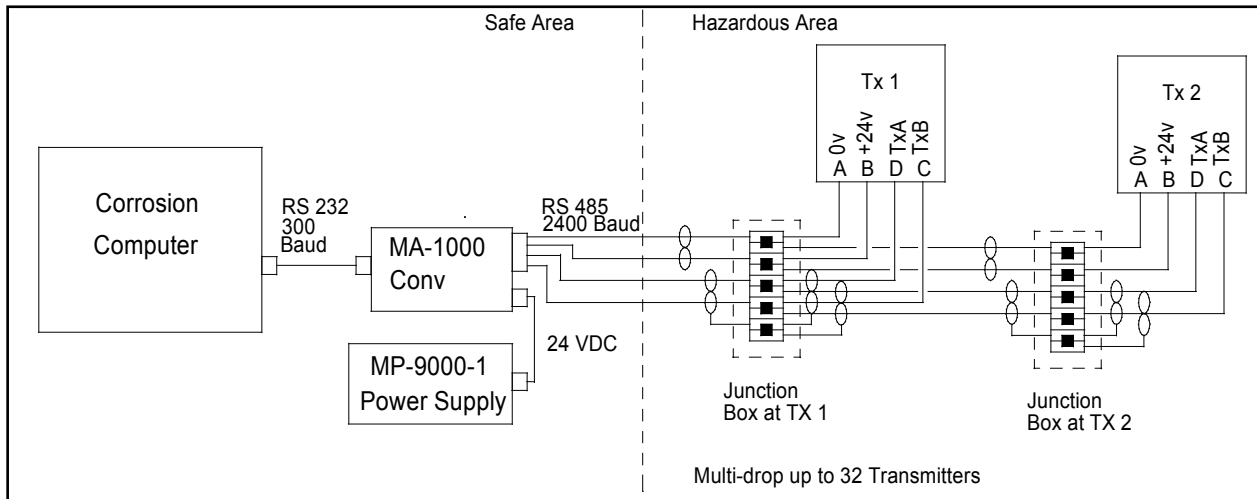

Figure 8 Connection with RS232/485 Converter

The terminal blocks in the junction boxes should be 10 way with adjacent pairs linked. This allows a single wire to be inserted into each terminal and provide proper connection.

Warning: Two wires should not be connected into one terminal block, as this may cause a high resistance connection or a completely failed connection. This is important particularly in multi-drop connection systems to avoid possible system failures.

On systems that use the RCS model MA-1000 converter for RS232 to RS485, and or 24 VDC power supply Model MP-9000-1, completely assembled RCS cables are generally used. Within these cables the same general color coding of wires is generally used, namely

Connector	Color	Pairs	Description
A	Black	Pair	0 VDC Supply
B	Red		24 VDC Supply
C	Green	Pair	RS 485 - Tx+ (B)
D	White or Black		RS 485 - Tx- (A)

RS 485 Drivers and Converters

The transmission is two-wire RS 485 on all units (computer and Corratel transmitters), so that they are all in the receive mode until switched on for a transmission, after which they return to the receive mode. Consequently, only one transmitter at a time must be addressed, and then the response awaited. The transmitter may take up to 1.5 seconds to respond. The Microcor-Corrater Tools and ICMS3/Amulet software require that any RS485 cards, RS232 to RS 485 converters, or fiber-optic converters have automatic switching for two-wire RS 485. When using such converters set up the baud rate for 2400 baud, and 8 bit, 1 start bit, 1 stop bit, and no parity if applicable. This sets the time delays associated with the automatic switching. Wrong settings can cause loss of transmissions and their replies.

Since the RS 485 bus on the Corratel transmitter operates at 2400 baud, line termination should not be required up to the maximum 4000 ft (1200 meters) that the RS 485 standard allows. At this baud rate all reflections from the end of line should have died before the next transmission character.

Bias is normally preset or settable on most converters. The standard settings for the converter will normally operate satisfactorily. Only on long RS485 lines with a large number of transmitters and if line termination resistors are used is it likely that the bias setting may have to be adjusted. See the documentation with that comes with the converter.

Checking Operation with Test Probe

A test probe is provided to allow testing of the proper operation of the transmitter. This test probe is very useful to distinguish if a problem is suspected with a probe or transmitter. By simply connecting the test probe to the transmitter in place of the probe, you can demonstrate if everything other than the probe and its cable and/or adapter is working correctly. The exact value is not usually particularly important, as it is usually more of a functional test. The actual reading on the transmitter should be within the range specified on the test probe.

If the test probe is being used to check the transmitter performance, the actual reading and any changes over time can be reviewed. The repeatability of the reading at constant temperature should be within the specified range.

Operation

CHAPTER 4

The Corratel transmitter is normally used with a corrosion computer running either Microcor and Corratel Tools software for simpler systems, or ICMS3-Amulet software for full corrosion management systems. For detailed operation of this software refer to the manual, P/N 100156.

The ICMS3-Amulet software allows continuous on-line monitoring and display of multiple Microcor and Corratel transmitters, typically up to 256 or more points. This is a full corrosion management system. With both systems, the reading interval may be set, typically at every 5 to 10 minutes. The probe alloy multiplier must also be set. The probe multiplier is a proportionality factor that relates the electrical polarization characteristics of a probe to its corrosion rate. See the software manual referenced above for detailed instructions.

UNS Code	Material	Multiplier
K03005	Pipe Grade Carbon Steel	1.00
A91100	Aluminum 1100-0	0.94
A92024	Aluminum 2024	0.88
C11000	Copper 110 ETP Comm. Pure	2.00
C44300	CDA 443 Arsenical Admiralty	1.67
C44500	CDA 445 Phosphorized Adm.	1.68
C64200	CDA 642 A1 Silicon Bronze	1.48
C68700	CDA 687 Alum. Brass Arsenical	1.62
C70610	CDA 706 90/10 Copper/Nickel	1.80
C71500	CDA 715 70/30 Copper/Nickel	1.50
G41300	AISI 4130 Alloy Steel	1.00
L50045	Lead	2.57
N04400	Monel 400 Nickel	1.13
N05500	Monel K-500 Nickel	1.04
N06022	Hastelloy C22	0.85
N06600	Inconel 600 Nickel	0.95
N08020	Carpenter 20 CB3 SST	0.98
N08800	Incolloy 800	0.89
N08825	Incolloy 825	0.88

UNS Code	Material	Multiplier
N10276	Hastelloy C276	0.86
R50400	ASTM B-348 Grades 2-4 Titanium	0.75
S30400	AISI 304 Stainless Steel	0.89
S31600	AISI 316 Stainless Steel	0.90
S31603	AISI 316L Stainless Steel	0.90
S31803	2205 Duplex Stainless Steel	0.89
S32750	2507 Duplex Stainless Steel	0.88
Z17001	Grades 1A, 1, 2, 3, or 5 Zinc	1.29

NOTE: These factors are recommended for use with the E-9020 when setting the MULTIPLIER value. They are based upon use of Corratel electrodes which have surface areas of 5cm² for “standard” probes and 0.5 cm² for “flush” probes.

ATEX Certifications

Appendix A

EC-TYPE EXAMINATION CERTIFICATE

[1]
[2]

Equipment or Protective System intended for use
in Potentially explosive atmospheres
Directive 94/9/EC



- [3] EC-Type Examination Certificate Number: DEMKO 03 ATEX 0215219
- [4] Equipment or Protective System: Transmitters for Monitoring Corrosion MT-9485, 9485A, ST-9485A and E-9020
- [5] Manufacturer: Rohrback Cosasco Systems Inc
- [6] Address: 11841 E Smith Ave, Santa Fe Springs CA 90670 USA
- [7] This equipment or protective system and any acceptable variation there to is specified in the schedule to this certificate and the documents therein referred to.
- [8] UL International Demko A/S, notified body number 0539 in accordance with Article 9 of the Council Directive 94/9/EC of 23 March 1994, certifies that this equipment or protective system has been found to comply with the Essential Health and Safety Requirements relating to design and construction of equipment and protective systems intended for use in potentially explosive atmospheres given in Annex II to the Directive.
- The examination and test results are recorded in confidential report no: 02NK15219
- [9] Compliance with the Essential Health and Safety Requirements has been assured by compliance with:
EN 50014: 1997 E, and Amendments 1 and 2, EN 50018 : 2000 E, and Amendment 1
- [10] If the sign "X" is placed after the certificate number, it indicates that the equipment or protective system is subject to special conditions for safe use specified in the schedule to this certificate.
- [11] This EC-Type examination certificate relates only to the design, examination and tests of the specified equipment or protective system in accordance to the Directive 94/9/EC. Further requirements of this Directive apply to the manufacturing process and supply of this equipment or protective system. These are not covered by the certificate.
- [12] The marking of the equipment or protective system shall include the following:

II 2G EEx d IIC T6

On behalf of UL International Demko A/S

Herlev, 2005-05-20

Karina Christiansen
Certification Manager

UL International Demko A/S

Lyskaer 8, P.O. Box 514
DK-2730, Herlev, Denmark
Telephone: +45 44856565
Fax: +45 44856500

Certificate 03 ATEX 0215219

This certificate may only be reproduced in its
entirety and without any change, schedule included



A Subsidiary of
**Underwriters
Laboratories Inc.**

P1

[13]

Schedule

[14]

EC-TYPE EXAMINATION CERTIFICATE No.

DEMKO 03 ATEX 0215219

[15] Description of Equipment or protective system:

The MT-9485, and -9485A Transmitters are used for cathodic protection, which is a method of corrosion control for pipe lines and tanks from external soil corrosion. The data is stored temporarily in the data transmission section, until the data is called up by a field master unit. The MT-9485 is modified by incorporating "auto ranging" capability into it and now designated MT-9485A.

The E-9020 is the same as the MT-9485 except for the electronic measuring circuit within the flame proof enclosure.

The ST-9485A is the same as the MT-9485 except for the probe sensing material.

Temperature Range:

Ambient temperature range: $-40^{\circ}\text{C} \leq T_{\text{amb}} \leq +70^{\circ}\text{C}$

Electrical data:

Supply Voltage:
3.6V battery and 10 to 36 V dc

Current Consumption at:
10 V dc....75 mA....750 mW
15 V dc....45 mA....675 mW
20 V dc....32 mA....640 mW
24 V dc....26 mA....624 mW
30 V dc....20 mA....600 mW

Routine Tests:

Each main enclosure with connectors fitted, shall be subjected to a routine overpressure test of 15.95 bar for at least 10 seconds and no greater than 60 seconds as required by clause 16.1 of EN50018. There shall be no permanent deformation or damage to the enclosure.

Each connector main body shall be subjected to a routine overpressure test of 14.5 bar for at least 10 seconds and no greater than 60 seconds as required by clause 16.1 of EN50018. There shall be no permanent deformation or damage to the enclosure.

Certificate: 03 ATEX 0215219
Report: 05NK07865

P 2 / 3

UL International Demko A/S This certificate may only be reproduced in its
entirety and without any change, schedule included
Lyskaer 8, P.O. Box 514
DK-2730, Herlev, Denmark
Telephone: +45 44856565
Fax: +45 44856500

 A Subsidiary of
**Underwriters
Laboratories Inc.**

[13]

Schedule

[14]

EC-TYPE EXAMINATION CERTIFICATE No.

DEMKO 03 ATEX 0215219

[16] Report No.: 0315219 Report [02NK15219]
[04NK22574]
[05NK07865]

Drawings:

Drawing Number	Rev./ Date	Model	Title
702106, 1/2	K	MT & ST	System diagram
702200	A	MT	Transmitter assembly
748215	E	MT & E	Connector Detail
14540 - 003	B	MT & E	Nut
3550 - 125	D	MT & E	Connector
3800 - 009	E	MT & E	Cover
2050 - 008	C	MT & E	Base
2050 - 009	J	MT	Base Assembly
702152	E	MT & E	Base Weldment
14100 - 076	B	MT	Nameplate, warning
14100 - 075	K	MT & ST	Nameplate, Transmitter
710951	2004-10-12	E	System diagram
710950	2004-09-03	E	Transmitter top assembly
710974	2004-09-03	E	Base Weldment
710975	2004-09-03	E	Nameplate, warning
710977	A/2004-09-21	E	Nameplate, transmitter
702201	-	ST	Transmitter assembly

The manufacturer shall inform the notified body concerning all modifications to the technical documentation as described in ANNEX III to Directive 94/9/EC of the European Parliament and the Council of 23 March 1994.

[17] Special conditions for safe use: None

[18] Essential Health and Safety Requirements

Concerning ESR this Schedule verifies compliance with the Ex standards only. The manufacturer's Declaration of Conformity declares compliance with other relevant Directives.

On behalf of UL International Demko A/S

Herlev, 2005-05-20

Karina Christiansen
Certification Manager

Certificate: 03 ATEX 0215219
Report: 05NK07865

P 3 / 3

UL International Demko A/S

Lyskaer 8, P.O. Box 514
DK-2730, Herlev, Denmark
Telephone: +45 44856565
Fax: +45 44856500

This certificate may only be reproduced in its
entirety and without any change, schedule included



A Subsidiary of
**Underwriters
Laboratories Inc.®**

Troubleshooting Procedure

Appendix B

What to do in case of no response from the transmitter:

Use HyperTerminal to test communication between the computer and transmitter. Open HyperTerminal from the Windows Start Menu: Programs > Accessories > Communications > HyperTerminal. Choose a name for the HyperTerminal connection (any name is fine, for example, Test). Connect using the serial COM port to which the transmitter is connected (the transmitter will be connected through a converter and power supply assembly). Enter the following in the Port Settings Window:

Bits per second: 2440
Data bits: 8
Parity: None
Stop bits: 1
Flow control: None

At the blinking cursor the following key combinations may be entered to test communications:

To poll each transmitter on the loop, type an uppercase letter “S”, that is: shift + S

This should return a reading for each transmitter connected on the loop. If a reading is not returned from each transmitter

If abnormal readings, or an excursion occurs that cannot be explained, the system electronics may be verified by connecting the meter prover in place of the probe and checking that the reading corresponds to 50% of the probe span. See “Checking Operation with Meter Prover” in Chapter 3 Installation.

If the meter prover shows the electronics to be operating correctly, then inspect the probe to transmitter connections, and the probe for damage, high resistance, or poor connections.

After initial application of power, the transmitter takes approximately one minute to start up during which time it will send the error code -999,999, or -999,996 when its data is requested. On ICMS3 systems these codes will show up as an error message.

-999,999 - “Startup Mode”.
-999,996 - “Auto Ranging”

If there is a probe or probe connection failure an error code -999,998 or -999,997 will be generated. On ICMS3 systems this will display as follows:

Code: -999,998 Display: Probe Fault (4)

Code: -999,997 Display: Probe Fault (1)

Theory of Operation of CORRATER® Systems

Appendix C

CORRATER® systems measure the instantaneous corrosion rate of a metal in a conductive fluid using the linear polarization resistance (“LPR”) measurement technique. Corrosion is an electrochemical process in which electrons are transferred between anodic and cathodic areas on the corroding metal resulting in oxidation (corrosion) of the metal at the anode and reduction of cations in the fluid at the cathode.

Sterns and Geary originally demonstrated that the application of a small polarizing potential difference (ΔE) from the corrosion potential (E_{corr}) of a corroding electrode resulted in a measured current density (i_{meas}) which is related to the corrosion current density (i_{corr}) by equation (1):

$$\Delta E_{i_{\text{meas}}} = \frac{b_a b_c}{(2.303 i_{\text{corr}})(b_a + b_c)} \quad (1)$$

where: b_a = Anodic Tafel Slope
 b_c = Cathodic Tafel Slope

Since the Tafel coefficients are more or less constant for a given metal/fluid combination, i_{meas} is proportional to i_{corr} which is proportional to the corrosion rate. Equation (1) and the entire LPR technique are only valid when the polarizing potential difference is very low (typically up to 20 mV). In this region the curves are linear, hence the term LPR.

Inspection of Equation (1) shows that the result is a resistance, the Polarization Resistance, R_p . While strictly speaking, there are both anodic and cathodic R_p values, which can differ, they are usually assumed to be equal. The resistance to current flow between anode and cathode on the LPR probe is the sum of both polarization resistance values and the resistance of the solution between the electrodes (R_s) as shown in Equation (2):

$$E = i_{\text{meas}} (2R_p + R_s) \quad (2)$$

From Equations (1) and (2), obtaining results from the LPR technique would seem to require only instantaneous readings of resistance. In practice, however, the determination of polarization resistance is complicated by a capacitance effect at the metal-fluid interface (double-layer capacitance). Figure A-1 is an equivalent electrical circuit of the corrosion cell formed by the measuring electrodes and the fluid, showing the importance of R_s and double-layer capacitance effects.

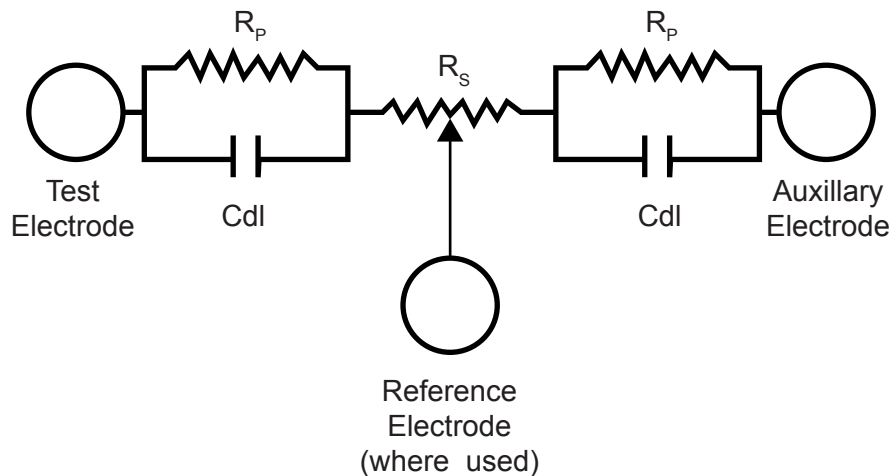

Figure A-1 Equivalent Circuit of LPR Probe

The effect of the double-layer capacitance is to require the direct current flow to initially charge-up the capacitors, resulting in a decaying exponential current flow curve vs. time after application of the polarizing potential difference. A typical LPR current vs. time curve is shown in Figure A-2.

Each metal/fluid interface has its own characteristic capacitance which in turn determines the amount of time required to obtain valid measurements of i_{corr} and corrosion rate. The actual time required can vary from a few seconds up to 20 minutes, depending upon the metal/process combination being measured. Choosing too short a polarization time can result in current readings much higher than the true i_{corr} thus causing measured corrosion rate to be lower than actual, sometimes by a significant amount.

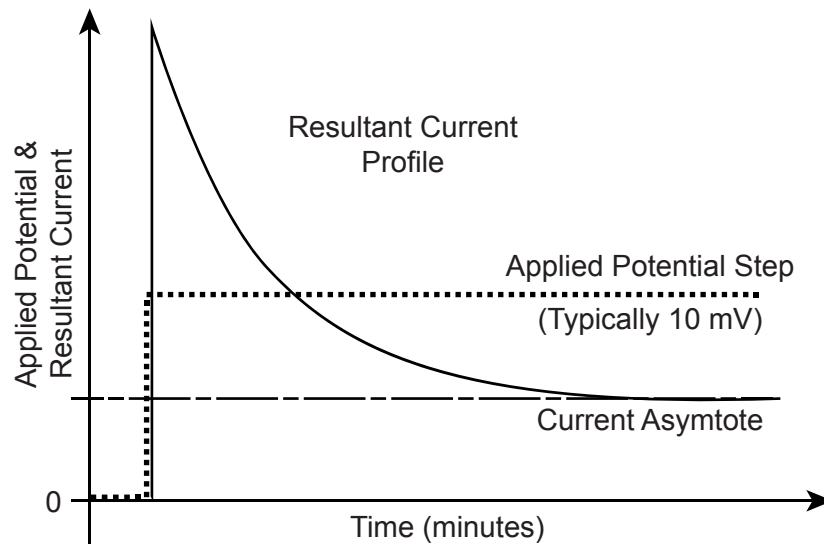

Figure A-2 Typical LPR Current vs. Time Decay Curve

Solution resistance can also have a significant effect on accuracy if it is relatively high compared to the polarization resistance. In most industrial water applications, conductivity of the solution is high and solution resistance is low compared to the polarization resistance, so i_{meas} is an accurate measure of polarization resistance, and therefore, corrosion rate.

A serious problem develops, however, when the solution resistance increases or the polarization resistance decreases enough to make the solution resistance a significant portion of the total resistance to current flow between the electrodes. In these cases, the accuracy of the LPR measurement is affected. This situation tends to occur at high corrosion rates (low polarization resistance) and in solutions with low conductivity (high solution resistance) and is manifested by the indicated (measured) corrosion rate being lower than the actual corrosion rate. The graph in Figure A-3 shows the effect of this limitation on the recommended operating range of LPR instruments.

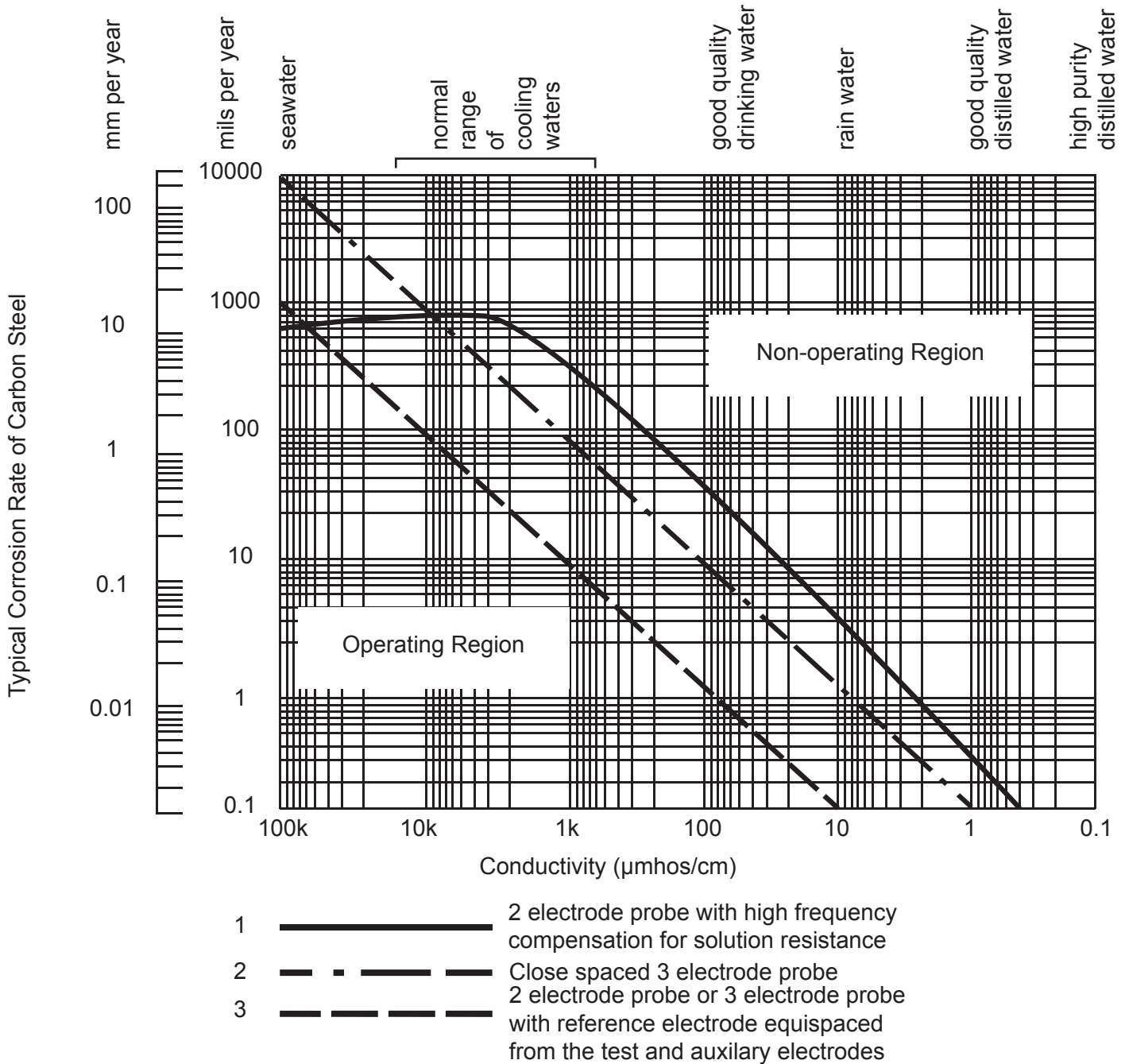

Figure A-3 Operating Range of LPR Instruments
Corrosion Rate vs. Solution Conductivity

Several techniques have been used over the years to minimize the impact of solution resistance on LPR measurements. The most common techniques involved the use of a three electrode probe. The effectiveness of the reference electrode in reducing the effect of solution resistance has been shown to be dependent upon the proximity of the reference electrode to the measurement electrode. Rohrback Cosasco three-electrode probes (see Figure A-4) are unique compared to other major LPR probes because they utilize a closely-spaced electrode.

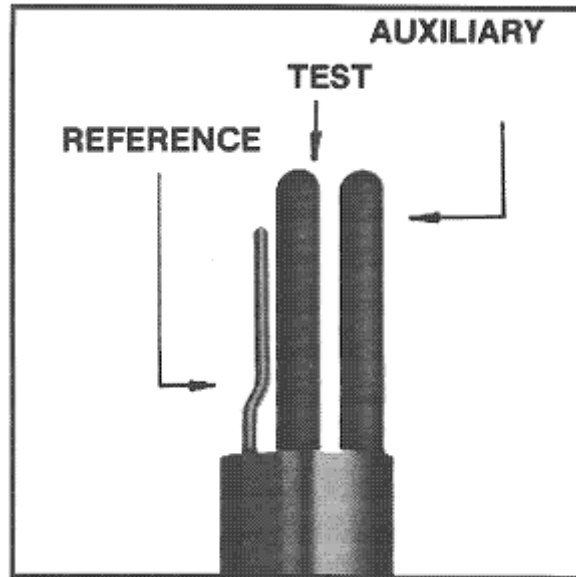

Figure A-4 Rohrbach Cosasco 3-Electrode Probe Configuration

A better way to deal with this problem, however, is to directly measure and compensate for the solution resistance. Rohrbach Cosasco has exclusive patent rights to the Solution Resistance Compensation (SRC) technique incorporated in most of the CORRATER® range of instruments. In this method, a high-frequency a.c. voltage signal is applied between the electrodes short-circuiting R_p through the double-layer capacitance, thereby directly measuring the solution resistance. The state-of-the-art, patented SRC technology also eliminates the need for a third electrode, even in low conductivity solutions. Consequently, Rohrbach Cosasco's two-electrode probes have become the standard RCS offering, with the three-electrode probe available on special order only.

The above points are clearly indicated in ASTM Standard Guide G96 which quotes:

“3.2.8 Two-electrode probes and three-electrode probes with the reference electrode equidistant from the test and auxiliary electrode do not correct for effects of solution resistance without special electronic solution resistance compensation. With high to moderate conductivity environments, this effect of solution resistance is not normally significant.”

“3.2.9 Three-electrode probes compensate for the solution resistance RS by varying degrees depending on the position and proximity of the reference electrode to the test electrode. With a close-spaced reference electrode, the effects of RS can be reduced up to approximately ten fold. This extends the operating range over which adequate determination of the polarization resistance can be made.”

3.2.10 A two-electrode probe with electrochemical impedance measurement technique at high frequency short circuits the double-layer capacitance, C_{dl} , so that a measurement of solution resistance R_s can be made for application as a correction. This also extends the operating range over which adequate determination of polarization resistance can be made.”

Imbalance (or Pitting/Index)

In addition to general or uniform corrosion, localized corrosion (pitting) may occur in a system. This can result in much more rapid failure of a structure than a simple measure of corrosion rate would indicate. A pit on the metal surface is the result of a localized, high anodic current density. Positive ions flow away from the pit into the solution and electrons flow away from the pit into the surrounding metal.

If it were possible to place a zero-impedance ammeter between the pit and the nearby metal surface, the current in the anode-cathode system of the pit could be measured. Individual measurements are not practical because the areas are small. Instead, current flow between the two metallurgically identical electrodes of a CORRATER® probe under short-circuit conditions can be used to indicate pitting tendency. All Rohrbach Cosasco CORRATER® instruments include a imbalance/pitting reading. The user should note that this is a qualitative measurement (or index) and utilize it accordingly. It has proven very useful in many applications (e.g. cooling water treatment) and offers information not generally available about a system except by coupons which lag behind actual events and offer no way of detecting upsets.

If the pitting reading is low compared to the corrosion reading, the pitting problem will probably be minimal. On the other hand, a pitting reading which is high compared to the corrosion reading can indicate that pitting or crevice corrosion will be the main form of corrosive attack. When the readings are about equal, some pitting is indicated, but the pits will probably be broad and shallow.