



1

BEFORE YOU START

1. The Receiver is designed to carry a maximum of 15 Amps. That is, for example, 15 Amps through one output or 5 Amps each through 3 outputs.
2. Master Output. This can be configured to Continuous or Parallel operation, see overleaf for details.
3. If Receiver outputs are connected in parallel with an external switching device (wired remote) the Receiver will instantly switch off when the wired remote is operated
4. Lodar Receivers **MUST** have an **isolation switch** for safety, to allow for registering a replacement Transmitter.
5. Safety Feature. Both the Transmitter and the Receiver will "time out" after 30 minutes of inactivity. This can be altered, ask your dealer.

2

IDENTIFY POWER CONNECTION POINT AND ISOLATE SUPPLY

Remove fuse

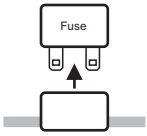

or Disconnect Battery



3

MOUNT RECEIVER

CAUTION



TAKE TIME TO LOCATE THE BEST POSITION

If necessary, power the Receiver and move it around the vehicle until the required performance is achieved. Operate the Transmitter and observe the Receiver internal LED's.

Mount as **HIGH** as possible
AVOID surfaces with **HEAVY VIBRATION**
AVOID DIRECT SPRAY from wheels
 In a **HOT CLIMATE** fit in a **SHADED** position
 Cable gland should face **DOWN** or **BACK**

Receiver 9206RX and 9306RX shown,
 Waterproof to IP67, complete with 3 metres (10 ft) cables

POSITIVE
 NEGATIVE

2 core cable.
 These are
 Power Inputs

7 core cable.
 These are
 Power Outputs

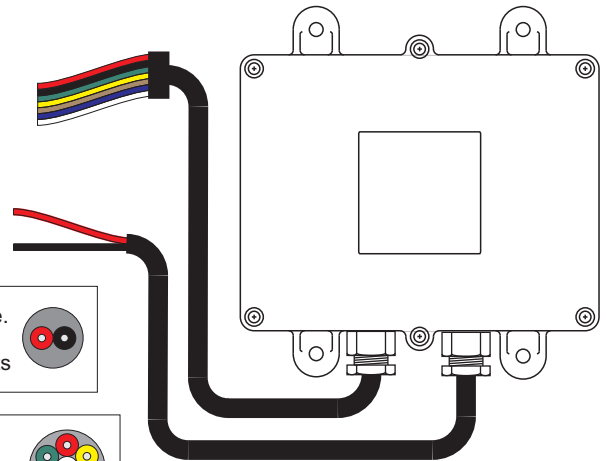

Secure using 5mm (3/16") bolts (not supplied) through the 4 mounting feet

4

CONNECT WIRES

Transmitter Function I.D.

RECEIVER WIRES Power Connections	
WIRE COLOUR	
RED	12 to 36 Volts DC Positive
BLACK	Negative

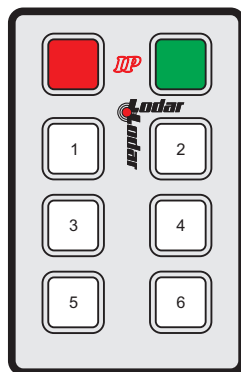

RECEIVER WIRES for given Transmitter Operation	
WIRE COLOUR	FUNCTION
GREEN	Output F1
YELLOW	Output F2
BROWN	Output F3
BLUE	Output F4
BLACK	Output F5
RED	Output F6
WHITE	Master Output

5

ACTIVATE SUPPLY

Replace fuse

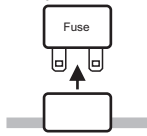

or re-connect Battery

6

TEST

Press the Transmitter **RESET** button to activate the system. Carefully test each function for correct operation.



Your product is marked with this symbol. It means that used electrical and electronic products should not be mixed with general household waste. There is a separate collection system for these products.
In the EEC - Please contact your National Distributor (see www.lodar.com for this information) who will inform you about the take-back of the product. You might be charged for the costs arising from the take-back and recycling. Small products might be taken back by your local collection facilities.
Outside the EEC - If you wish to discard this product please contact your local authorities and ask for the correct method of disposal

FM Series - Effective working range up to a distance of 60 metres (200 feet).
Narrow Band FM Series - Effective working range up to a distance of 300 metres (1000 feet)

STOP Button switches off the Receiver and the keypad function buttons

L.E.D. Blinks when Transmitter and Receiver are active.

L.E.D. ON when a Transmitter Button is pressed.

L.E.D. FLASHES when batteries are low and a Button is pressed

4 Release Screws for Battery Compartment at rear.

4 x AAA batteries



RESET Button activates the Receiver and the keypad function buttons

Function Buttons

SAFETY FEATURE

The Transmitter automatically transmits a **STOP** signal after 30 minutes; this de-activates the Receiver and the Transmitter keypad.

To register Transmitters to the Receiver.

Switch OFF or DISCONNECT the power to the Receiver.

Switch ON or Reconnect the power to the Receiver.

This opens a 20 second registration window in the Receiver processor.
If you are looking at the Receiver PCB the Fault LED Flashes.

Immediately PRESS and HOLD the Transmitter Reset Button (Indicated) for 5 seconds during this 20 second window.

When the Transmitter is Registered the Fault LED lights continuously

IF YOU ARE REGISTERING TWO TRANSMITTERS THEN WITHIN 2 SECONDS

PRESS and then HOLD the second Transmitter Reset Button (indicated) for 5 seconds all during the 20 second window.

When the second Transmitter is Registered the Fault LED goes out and the Set LED comes on.
 Both your Transmitters are now operating the Receiver.

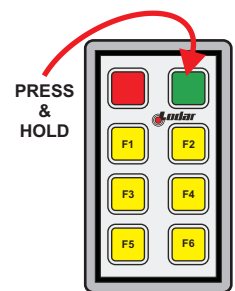

Connection Detail

S-, S+ Connections For Safety Solenoid etc. Part No. 9820 or 9821

Supply 12/24 V DC 40 Volts ABSOLUTE MAX

Outputs F1, F2, F3, F4, F5, F6 and Master.

The Receiver is designed to handle 15 Amps, current draw in excess of this will trigger a system shut down.

Any output can handle this maximum current.

SMA connector for External Aerial Antenna Part No. 9861, 9862, 9863 or 9869

Standard (Internal) Antenna connection

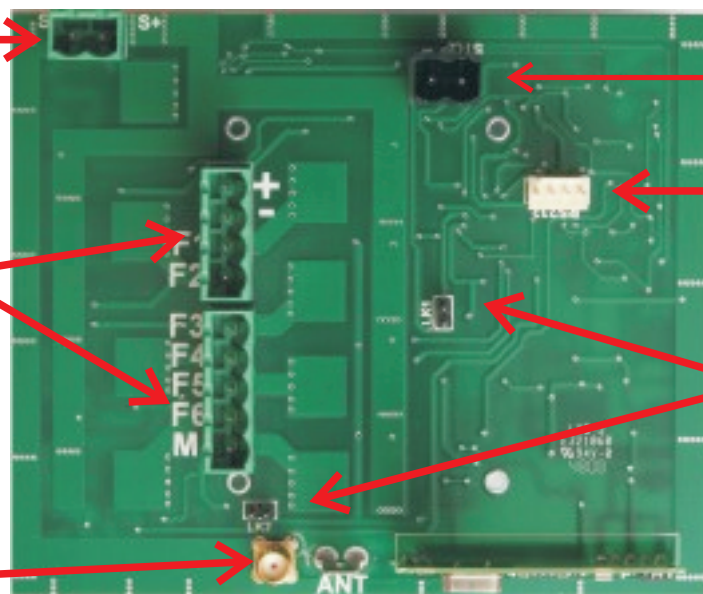

STOP and -, when connected together will cause the Receiver to power down

RS232 connection for programming and special features

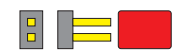

Lk1, when bridged causes the Master Output to be Parallel

LK2, when bridged causes the Master Output to be Continuous

Jumper MUST be fitted to only ONE link

POWER DOWN RECEIVER BEFORE MAKING CHANGES

Component Detail

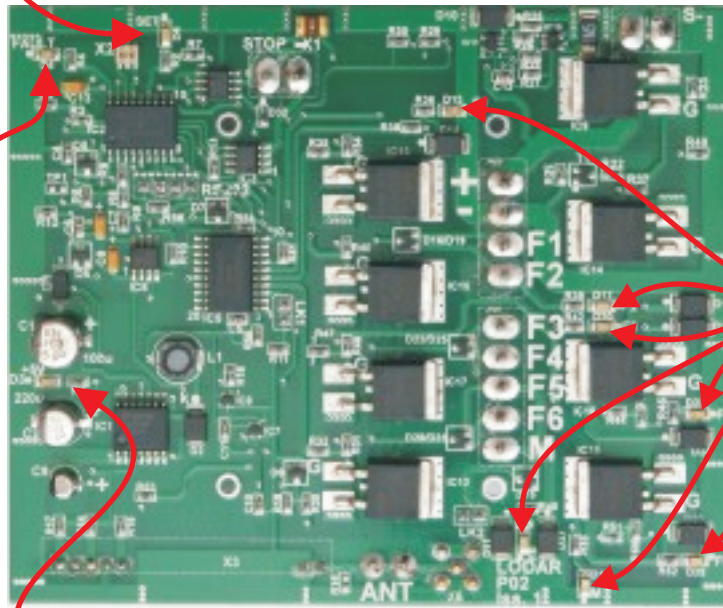

LED marked "SET"

Indicates system is active

LED's marked "F1 - F2 - F3 - F4 - F5 - F6 and M"

When **ON** indicate an output to that function

LED marked "FAULT"

Indicates an overload is present; the System cannot be **RESET** until overload is removed.

This LED blinks for 20 seconds when the Receiver is initially powered. A replacement Transmitter has to be registered during this 20 second period.

LED marked "5V"

Indicates power supply for control circuits is OK

VOLTAGE

Working Range
12 Volts to 36 Volts DC

Limits
8 Volts minimum to
40 Volts absolute max.

Note 42 Volt System
48 Volt Max is currently
Special Order

FAULT CHECK

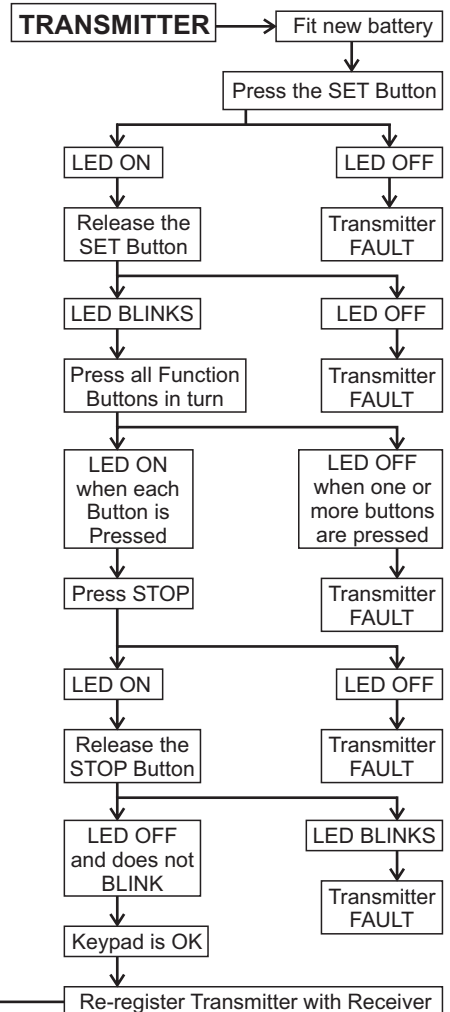
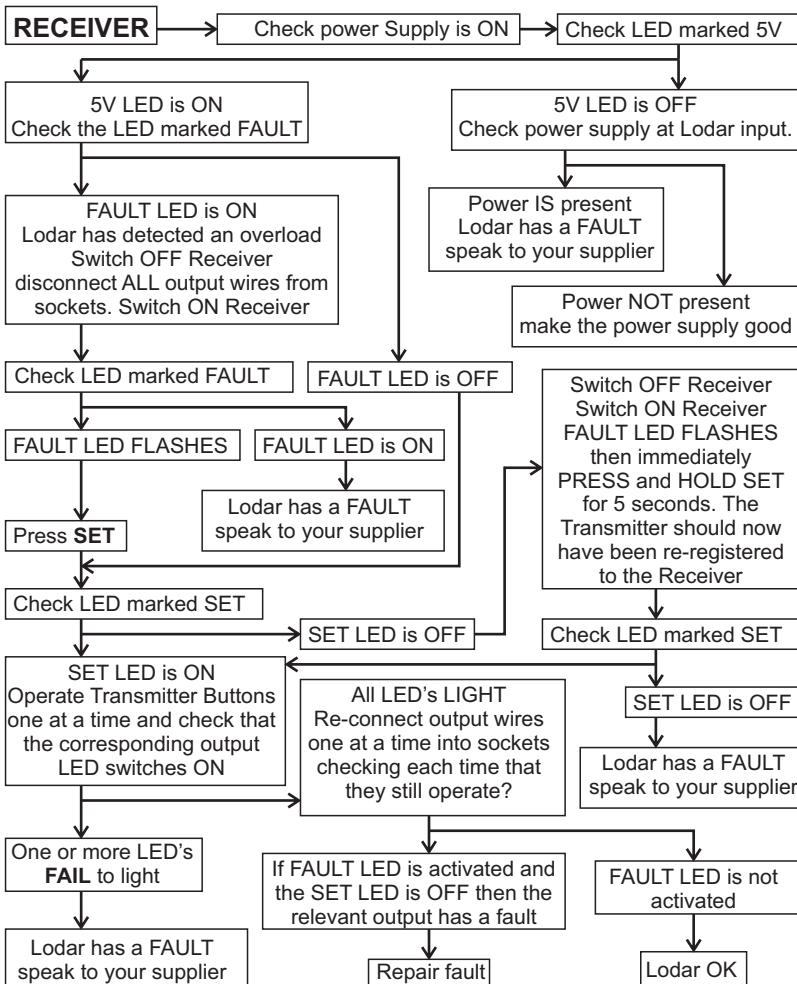

Skidmore 4WD Limited Warranty for LODAR Valid Worldwide

Limited Warranty.

Skidmore 4wd Ltd ("Seller") warrants to the original buyer ("You") all parts and components to be free of faults in materials workmanship for a period of two (2) years from provable date of purchase. Any Lodar product that is faulty will be repaired or replaced without charge to you, upon compliance with these procedures. The Warranties set forth herein are exclusive and in lieu of all other Warranties, whether oral or written, express or implied.

Limited Warranty Performance Procedure

Upon discovery of a faulty Lodar product, you shall notify the Seller in writing, at his factory or at any authorised distributor, details of the said fault and mail, or otherwise ship the faulty Lodar product, postage or other carriage prepaid. Repairs or replacements by the Seller under this Limited Warranty will normally be accomplished within fifteen (15) working days after the receipt of the faulty Lodar product. The Seller, or its authorised distributor, may make reasonable charges for repairs that are not covered by this Limited Warranty

Warranty and Remedy Limitations and Exclusions

The following exclusions or limitations of Warranties and limitations of remedies shall be expressly applicable:

Express Warranties. Seller warrants that the Lodar is as described in the "Lodar Owners Manual" provided herewith: no other express Warranty is made in respect to the Lodar. If any model or sample was shown to you, such model or sample was used for illustrative purposes only, and shall not be construed as a Warranty that the Lodar will conform to the sample or model.

Implied Warranties. The implied Warranty of merchantability and all other implied Warranties shall only extend from the provable date of purchase for two(2) years. Some States within the USA do not allow limitations on how long an implied Warranty lasts, so the above limitation may not apply to you.

Incidental and Consequential Damage. Subject to the Sellers Limited Warranty obligations set forth herein, the Seller shall not be responsible for incidental damages of any kind, or for consequential damages to property, loss of profits and loss of use which may be caused by any fault in, or malfunction, or failure of the enclosed Lodar. Some States within the USA do not allow the exclusion or limitation of incidental or consequential damages, so the above limitation may not apply to you.

Condition of Warranty. The Seller shall not be required to comply with its Warranty duties provided herein if the fault, malfunction or failure of the Lodar was caused by damage (not resulting from faulty or malfunctioning components) or unreasonable use by you. Unreasonable use shall include, but not be limited to, the failure to provide reasonable and necessary maintenance or installation or use of the Lodar without compliance with the instructions contained in the Lodar Owners manual. Sellers liability under this Warranty or for any loss or damage to the Lodar product shall not exceed the cost of correcting the defects in or replacing the Lodar product, and upon expiration of the Warranty period, all such liability shall terminate. The agents, distributors and employees of the Seller are not authorised to make modifications to this Warranty, or additional Warranties binding on the Seller. Accordingly, additional statements, whether oral or written, do not constitute Warranties and should not be relied upon.

Legal Remedies of the Buyer

This limited Warranty gives you specific legal rights, and you may also have other legal rights, which may vary from State to State within the USA and from country to country. You also have implied Warranty rights. In the event of a problem with Limited Warranty service or performance, you may be able to go to a small claims court, a state court or a federal district court in the USA or to appropriate jurisdictions outside the USA.

Enquiries

Any enquiries regarding compliance with Warranties provided herein may be addressed in writing to:
Skidmore 4WD Limited, 60 Sandwell Street, Walsall WS1 3EB, England.

We, Skidmore 4wd Ltd., 60 Sandwell St., Walsall. WS1 3EB England.

Declare under our sole responsibility that the product:

Product Details	Name	- Lodar	
	Series	- 92 2 00	93 2 00
	Type	- 92 2 06	93 2 06

To which this declaration relates is in conformity with the essential requirements and other relevant requirements, and is compliant with the standards and/or other documents, of the following directives :

EN 301 489-3	
R&TTE	(1999/5/EC)
Safety	Low Voltage Directive 300.683
	BS EN 954-1 to Category 3.
	BS EN 60204-1
EMC	2004/104/EEC ETSI 300-220 v1.1.1
Automotive EMC	Approval Granted - e11*72/245*95/54*3087*00
FCC	Approval Granted
Spectrum	433.92 MHz F1D (EUROPE CE E)
	418.0 MHz F1D (USA)

Please note that this certificate only covers Lodar and not the installation

Martin Skidmore	Position	Date
	CEO	January 2009

**F.C.C. PART 15 INTENTIONAL RADIATOR MANUAL STATEMENT
RADIO FREQUENCY INTERFERENCE STATEMENT**

Note, this equipment has been tested and found to comply with the limits for an intentional radiator, pursuant to Part 15, subpart C of the F.C.C. Rules. This equipment generates uses and can radiate radio frequency energy. If not installed and used in accordance with the instructions, it may cause interference to radio communications.

The limits are designed to provide reasonable protection against such interference in a residential situation. However there is no guarantee that interference will not occur in a particular installation. If this equipment does cause interference to radio or television reception, which can be determined by turning the equipment on and off, the user is encouraged to try to correct the interference by one or more of the following measures:

- Reorient or relocate the receiving antenna of the affected radio or television
- Increase the separation between the equipment and the affected receiver.
- Connect the equipment and the affected receiver to power outlets on separate circuits.
- Consult the dealer or experienced radio/TV technician for help.

MODIFICATIONS

Changes or modifications not expressly approved by Skidmore 4wd Ltd. could void the users authority to operate the equipment

Lodar 92 1 00 FM Series and 93 1 00 Narrow Band FM Series are guaranteed for a period of 5 Years (with conditions) from the date of purchase, as long as it is wired in accordance with our instructions and that **the equipment is fitted with an isolation system to shut off all power in event of an emergency.**

CONTACT INFORMATION

Lodar
60 Sandwell Street,
Walsall, WS1 3EB.
England

Tel: +44 (0)1922 613633
Fax: +44 (0)1922 626991
email: sales@lodar.com

www.lodar.com

FM Series

System Part No.	Transmitter Part No.
USA ONLY	- 418 MHz
92 2 06-8 <input type="checkbox"/>	92 2 06TX-8

Rest of the World	- 433.92 MHz
92 2 06-3 <input type="checkbox"/>	92 2 06TX-3

Narrow Band FM Series

System Part No.	Transmitter Part No.
93 2 06-x <input type="checkbox"/>	93 2 02TX-x

(where "x" is the channel number)
Channel No. 1 2 3 4 5

Date purchased

Serial No.

For your records, put a cross in the relevant box , & enter date purchased & serial No.