

## 1 BEFORE YOU START

- The Receiver is designed to carry a maximum of 15 Amps. That is, for example, 15 Amps through one output or 5 Amps each through 3 outputs.
- Master Output. This can be configured to Continuous or Parallel operation, see overleaf for details.
- If Receiver outputs are connected in parallel with an external switching device (wired remote) the Receiver will instantly switch off when the wired remote is operated
- Lodar Receivers **MUST** have an **isolation switch** for safety, to allow for registering a replacement Transmitter.
- Safety Feature. Both the Transmitter and the Receiver will “time out” after 30 minutes of inactivity. This can be altered, ask your dealer.

## 2 IDENTIFY POWER CONNECTION POINT AND ISOLATE SUPPLY

Remove fuse

or Disconnect Battery

**WARNING**

Vehicle batteries contain gases which are flammable and explosive. Wear eye protection and do not lean over battery while disconnecting. Do not wear metal jewellery.

## 3 MOUNT RECEIVER

**CAUTION**

TAKE TIME TO LOCATE THE BEST POSITION

If necessary, power the Receiver and move it around the vehicle until the required performance is achieved. Operate the Transmitter and observe the Receiver internal LED's.

Mount as **HIGH** as possible  
**AVOID** surfaces with **HEAVY VIBRATION**  
**AVOID DIRECT SPRAY** from wheels  
 In a **HOT CLIMATE** fit in a **SHADED** position  
 Cable gland should face **DOWN** or **BACK**

92 00 RX & 93 00 RX have 4 core cable

92 02/4 RX & 93 02/4 RX have 7 core cable

Secure using 5mm (3/16") bolts (not supplied) through the 4 mounting feet

## 4 CONNECT WIRES

Transmitter Function I.D.

RECEIVER WIRES for given Transmitter Operation			
WIRE COLOUR	FUNCTION	9200 9300	9204 9302 9304
RED	12 to 36 Volts DC Positive	YES	YES YES
BLACK	Negative	YES	YES YES
GREEN	Output F1	YES	YES YES
YELLOW	Output F2	YES	YES YES
BROWN	Output F3	NOT AVAILABLE	NOT USED YES
BLUE	Output F4	NOT AVAILABLE	NOT USED YES
WHITE	Master Output	NOT AVAILABLE	YES YES

## 5 ACTIVATE SUPPLY

Replace fuse

or re-connect Battery

## 6 CONNECT TRANSMITTER BATTERY

Batteries generally have to be disconnected when shipping.

Your product is marked with this symbol. It means that used electrical and electronic products should not be mixed with general household waste. There is a separate collection system for these products.

**In the EEC** - Please contact your National Distributor (see [www.lodar.com](http://www.lodar.com) for this information) who will inform you about the take-back of the product. You might be charged for the costs arising from the take-back and recycling. Small products might be taken back by your local collection facilities.

**Outside the EEC** - If you wish to discard this product please contact your local authorities and ask for the correct method of disposal

## 7 TEST

Press the Transmitter **RESET** button to activate the system, and carefully test each function for correct operation.

**FM Series - Effective working range up to a distance of 60 metres (200 feet).**  
**Narrow Band FM Series - Effective working range up to a distance of 300 metres (1000 feet)**

**STOP** Button switches off the Receiver and the keypad function buttons

**L.E.D. Blinks** when Transmitter and Receiver are active.

**L.E.D. ON** when a Transmitter Button is pressed.

**L.E.D. FLASHES** when batteries are low and a Button is pressed

4 Release Screws for Battery Compartment at rear.

4 x AAA batteries



**RESET** Button activates the Receiver and the keypad function buttons

Function Buttons



**SAFETY FEATURE**

The Transmitter automatically transmits a **STOP** signal after 30 minutes; this de-activates the Receiver and the Transmitter keypad.

**To register a replacement Lodar Transmitter to a Receiver.**

Step 1.  
Switch OFF or DISCONNECT the power to the Receiver.

Step 2.  
Switch ON or Reconnect the power to the Receiver.  
This opens a 20 second registration window in the Receiver.  
*If you are looking at the Receiver PCB the Fault LED Flashes.*

Step 3.  
Immediately PRESS and HOLD the Transmitter Green Button for a minimum of 10 seconds during this 20 second window.  
*When the Transmitter is Registered the Fault LED goes out, and the Set LED comes on.*

Your Transmitter is now operating the Receiver.

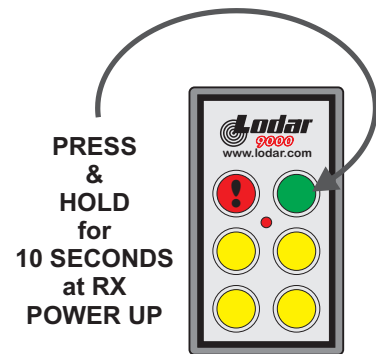

**Connection Detail**

S-, S+ Connections For Safety Solenoid etc. Part No. 9820 or 9821

Supply 12/24 V DC 40 Volts ABSOLUTE MAX

Outputs sockets +, -, F1 & F2 F3, F4, and Master.

The Receiver is designed to handle 15 Amps, current draw in excess of this will trigger a system shut down.

Any output can handle this maximum current.

SMA connector for External Aerial Antenna Part No. 9861, 9862, 9863 or 9869

Standard (Internal) Antenna connection

STOP and -, when connected together will cause the Receiver to power down

RS232 connection for programming and special features



Lk1, when bridged causes the Master Output to be Parallel

LK2, when bridged causes the Master Output to be Continuous

Jumper MUST be fitted to only ONE link

**POWER DOWN RECEIVER BEFORE MAKING CHANGES**

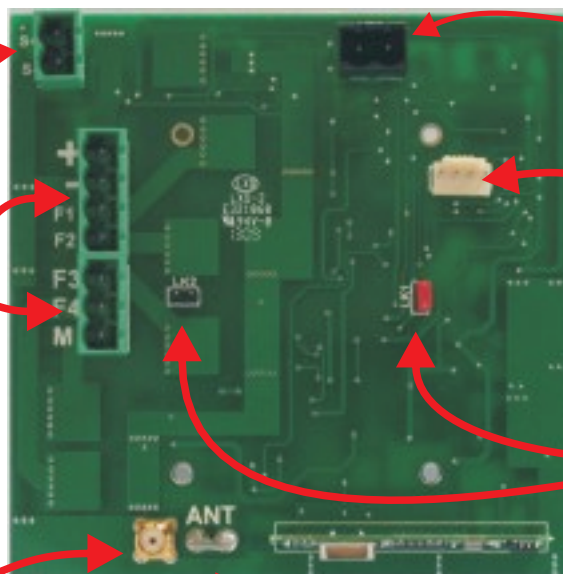

# Component Detail

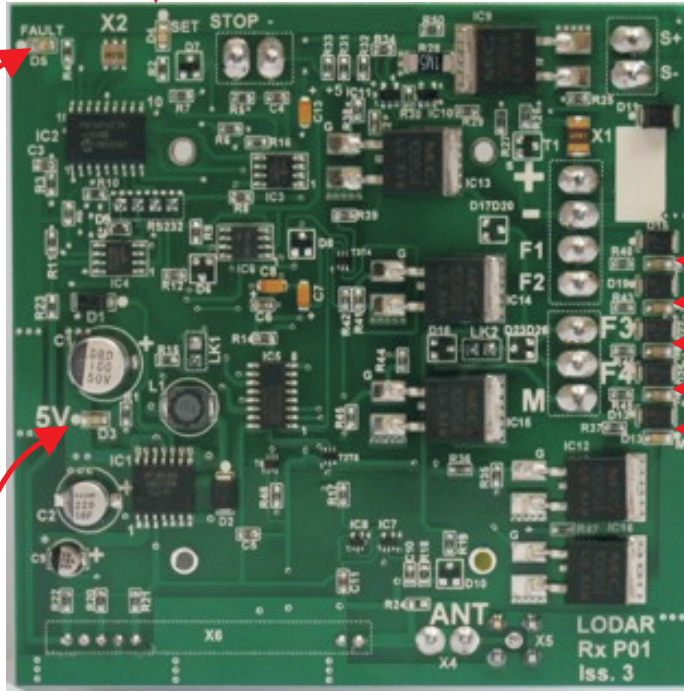

**LED marked "SET"**  
Indicates system is active

**LED's marked "F1 - F2 - F3 - F4 and M"**  
When ON indicate an output to that function

**LED marked "FAULT"**  
Indicates an overload is present; the System cannot be **RESET** until overload is removed.  
  
This LED blinks for 20 seconds when the Receiver is initially powered. A replacement Transmitter has to be registered during this 20 second period.

**LED marked "5V"**  
Indicates power supply for control circuits is OK

**VOLTAGE**  
Working Range  
12 Volts to 36 Volts DC  
  
Limits  
8 Volts minimum to 40 Volts absolute max.  
  
Note 42 Volt System  
48 Volt Max is currently Special Order

## FAULT CHECK

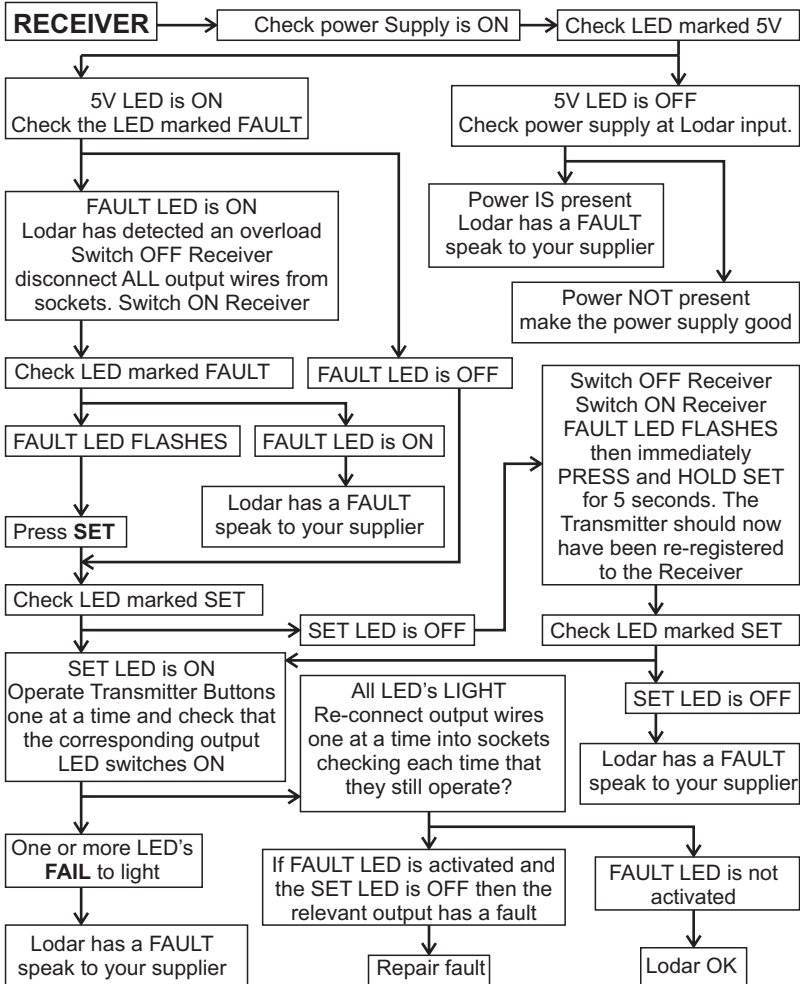
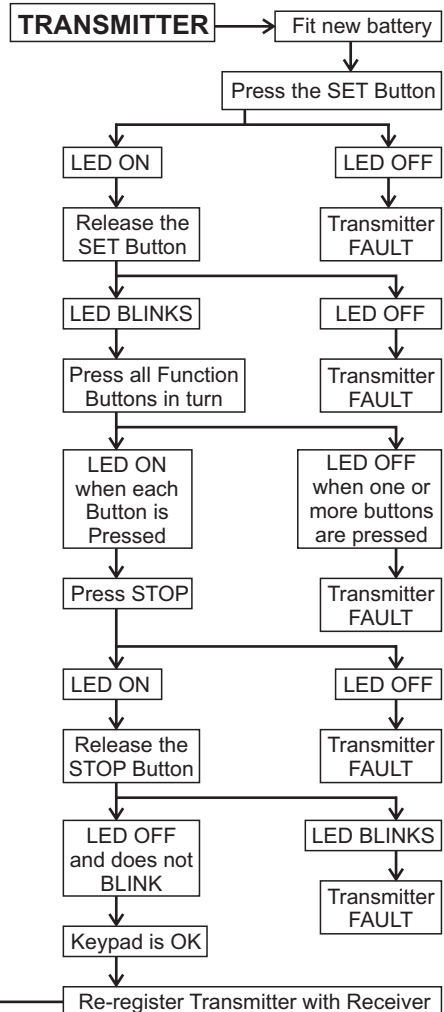

**Skidmore 4WD Limited Warranty for LODAR Valid Worldwide**

**Limited Warranty.**

Skidmore 4wd Ltd ("Seller") warrants to the original buyer ("You") all parts and components to be free of faults in materials workmanship for a period of two (2) years from provable date of purchase. Any Lodar product that is faulty will be repaired or replaced without charge to you, upon compliance with these procedures. The Warranties set forth herein are exclusive and in lieu of all other Warranties, whether oral or written, express or implied.

**Limited Warranty Performance Procedure**

Upon discovery of a faulty Lodar product, you shall notify the Seller in writing, at his factory or at any authorised distributor, details of the said fault and mail, or otherwise ship the faulty Lodar product, postage or other carriage prepaid. Repairs or replacements by the Seller under this Limited Warranty will normally be accomplished within fifteen (15) working days after the receipt of the faulty Lodar product. The Seller, or its authorised distributor, may make reasonable charges for repairs that are not covered by this Limited Warranty

**Warranty and Remedy Limitations and Exclusions**

The following exclusions or limitations of Warranties and limitations of remedies shall be expressly applicable:

**Express Warranties.** Seller warrants that the Lodar is as described in the "Lodar Owners Manual" provided herewith: no other express Warranty is made in respect to the Lodar. If any model or sample was shown to you, such model or sample was used for illustrative purposes only, and shall not be construed as a Warranty that the Lodar will conform to the sample or model.

**Implied Warranties.** The implied Warranty of merchantability and all other implied Warranties shall only extend from the provable date of purchase for two(2) years. Some States within the USA do not allow limitations on how long an implied Warranty lasts, so the above limitation may not apply to you.

**Incidental and Consequential Damage.** Subject to the Sellers Limited Warranty obligations set forth herein, the Seller shall not be responsible for incidental damages of any kind, or for consequential damages to property, loss of profits and loss of use which may be caused by any fault in, or malfunction, or failure of the enclosed Lodar. Some States within the USA do not allow the exclusion or limitation of incidental or consequential damages, so the above limitation may not apply to you.

**Condition of Warranty.** The Seller shall not be required to comply with its Warranty duties provided herein if the fault, malfunction or failure of the Lodar was caused by damage (not resulting from faulty or malfunctioning components) or unreasonable use by you. Unreasonable use shall include, but not be limited to, the failure to provide reasonable and necessary maintenance or installation or use of the Lodar without compliance with the instructions contained in the Lodar Owners manual. Sellers liability under this Warranty or for any loss or damage to the Lodar product shall not exceed the cost of correcting the defects in or replacing the Lodar product, and upon expiration of the Warranty period, all such liability shall terminate. The agents, distributors and employees of the Seller are not authorised to make modifications to this Warranty, or additional Warranties binding on the Seller. Accordingly, additional statements, whether oral or written, do not constitute Warranties and should not be relied upon.

**Legal Remedies of the Buyer**

This limited Warranty gives you specific legal rights, and you may also have other legal rights, which may vary from State to State within the USA and from country to country. You also have implied Warranty rights. In the event of a problem with Limited Warranty service or performance, you may be able to go to a small claims court, a state court or a federal district court in the USA or to appropriate jurisdictions outside the USA.

**Enquiries**

Any enquiries regarding compliance with Warranties provided herein may be addressed in writing to:  
Skidmore 4WD Limited, 60 Sandwell Street, Walsall WS1 3EB, England.

We, Skidmore 4wd Ltd., 60 Sandwell St., Walsall. WS1 3EB England.

Declare under our sole responsibility that the product:

Product Details	Name	- Lodar	
	Series	- 92 2 00	93 2 00
	Type	- 92 2 04	93 2 04

To which this declaration relates is in conformity with the essential requirements and other relevant requirements, and is compliant with the standards and/or other documents, of the following directives :

EN 301 489-3	(1999/5/EC)	
R&TTE	Low Voltage Directive 300.683	
Safety	BS EN 954-1 to Category 3.	
	BS EN 60204-1	
EMC	2004/104/EEC	ETSI 300-220 v1.1.1
Automotive EMC	Approval Granted - e11*72/245*95/54*3087*00	
FCC	Approval Granted	
Spectrum	433.92 MHz F1D (EUROPE)	CE
	418.0 MHz F1D (USA)	

Please note that this certificate only covers Lodar and not the installation

Martin Skidmore	Position	Date
	CEO	January 2009

**F.C.C. PART 15 INTENTIONAL RADIATOR MANUAL STATEMENT  
RADIO FREQUENCY INTERFERENCE STATEMENT**

Note, this equipment has been tested and found to comply with the limits for an intentional radiator, pursuant to Part 15, subpart C of the F.C.C. Rules. This equipment generates uses and can radiate radio frequency energy. If not installed and used in accordance with the instructions, it may cause interference to radio communications.

The limits are designed to provide reasonable protection against such interference in a residential situation. However there is no guarantee that interference will not occur in a particular installation. If this equipment does cause interference to radio or television reception, which can be determined by turning the equipment on and off, the user is encouraged to try to correct the interference by one or more of the following measures:

- Reorient or relocate the receiving antenna of the affected radio or television
- Increase the separation between the equipment and the affected receiver.
- Connect the equipment and the affected receiver to power outlets on separate circuits.
- Consult the dealer or experienced radio/TV technician for help.

**MODIFICATIONS**

Changes or modifications not expressly approved by Skidmore 4wd Ltd. could void the users authority to operate the equipment

Lodar 92 1 00 FM Series and 93 1 00 Narrow Band FM Series are guaranteed for a period of 5 Years (with conditions) from the date of purchase, as long as it is wired in accordance with our instructions and that **the equipment is fitted with an isolation system to shut off all power in event of an emergency.**

**CONTACT INFORMATION**

Lodar  
60 Sandwell Street,  
Walsall, WS1 3EB.  
England

Tel: +44 (0)1922 613633  
Fax: +44 (0)1922 626991  
email: sales@lodar.com

**www.lodar.com**

**FM Series**

System Part No.	Transmitter Part No.
USA ONLY	- 418 MHz
92 2 00-8 <input type="checkbox"/>	92 2 02TX-8
92 2 02-8 <input type="checkbox"/>	92 2 02TX-8
92 2 04-8 <input type="checkbox"/>	92 2 04TX-8
Rest of the World	- 433.92 MHz
92 2 00-3 <input type="checkbox"/>	92 2 02TX-3
92 2 02-3 <input type="checkbox"/>	92 2 02TX-3
92 2 04-3 <input type="checkbox"/>	92 2 04TX-3

**Narrow Band FM Series**

System Part No.	Transmitter Part No.
93 2 00-x <input type="checkbox"/>	93 2 02TX-x
93 2 02-x <input type="checkbox"/>	93 2 02TX-x
93 2 04-x <input type="checkbox"/>	93 2 04TX-x

(where "x" is the channel number)

Channel No. 1  2  3  4  5

Date purchased

Serial No.

For your records, put a cross in the relevant box , & enter date purchased & serial No.