

DV4500i

4500lb High Performance Trailer Winch



PN641656 12V
PN642037 24V

Features Include

- Power in and power out
- Sliding ramping clutch for rapid wire rope payout
- Circuit breakers shut off winch to prevent overheating of motor
- Weather-resistant plastic housing for extra durability
- Dynamic and mechanical brake holds full load
- Integrated contactor for complete protection of wirings
- Compact and light weight allows for a wide range of applications

Specifications

- Rated line pull: 2,041 kg / 4,500 lb single line
- Motor: 1,200 w / 1.6 hp 12/24V permanent magnet
- Gear train: 3-stage planetary 170:1
- Clutch (freespooling): Sliding ramping
- Brake (outside the drum): Automatic load-holding mechanical brake
- Drum size: 54 x 83 mm
- Control: Handheld pendant switch remote control
- Rope type: Galvanized aircraft A7 x 19
- Rope size: 6.3 mm x 15.2 m
- Mounting bolts pattern: 86 x 93 mm

Line Speed and Amp. Draw (1st layer of wire rope on the drum):

Line Pull, kg / lb	Line Speed, mpm / fpm	Amp. Draw, A	
		12V	24V
No Load	6.5 / 21.3	25	10
545 / 1,000	5 / 16.4	110	55
907 / 2,000	3.6 / 11.8	210	95
1,134 / 2,500	3.2 / 10.5	240	110
1,361 / 3,000	2.5 / 8.2	270	120
1,588 / 3,500	1.8 / 5.9	290	140
1,814 / 4,000	1.4 / 4.6	310	155
2,041 / 4,500	0.4 / 1.3	330	170

Line Pull and Rope Capacity:

Layer of Rope	Pull by Layer, kg / lb	Total Rope on the Drum, m / ft
1 st	2,041 / 4,500	2.4 / 7.9
2 nd	1,688 / 3,722	5.3 / 17.4
3 rd	1,440 / 3,174	8.7 / 28.6
4 th	1,255 / 2,766	12.6 / 41.4
5 th	1,112 / 2,451	15.2 / 50

Warning!

Winches are not to be used for the lifting or moving of persons.

The rated line pull shown is based on the first layer of rope on the drum.

The rope shall remain with a minimum of 5 wraps on the drum.

Warranty

Limited lifetime warranty for mechanical components, one (1) year warranty for electrical components.

WIRE ROPES ARE NOT INCLUDED UNDER WARRANTY.

Dimension, mm/in:

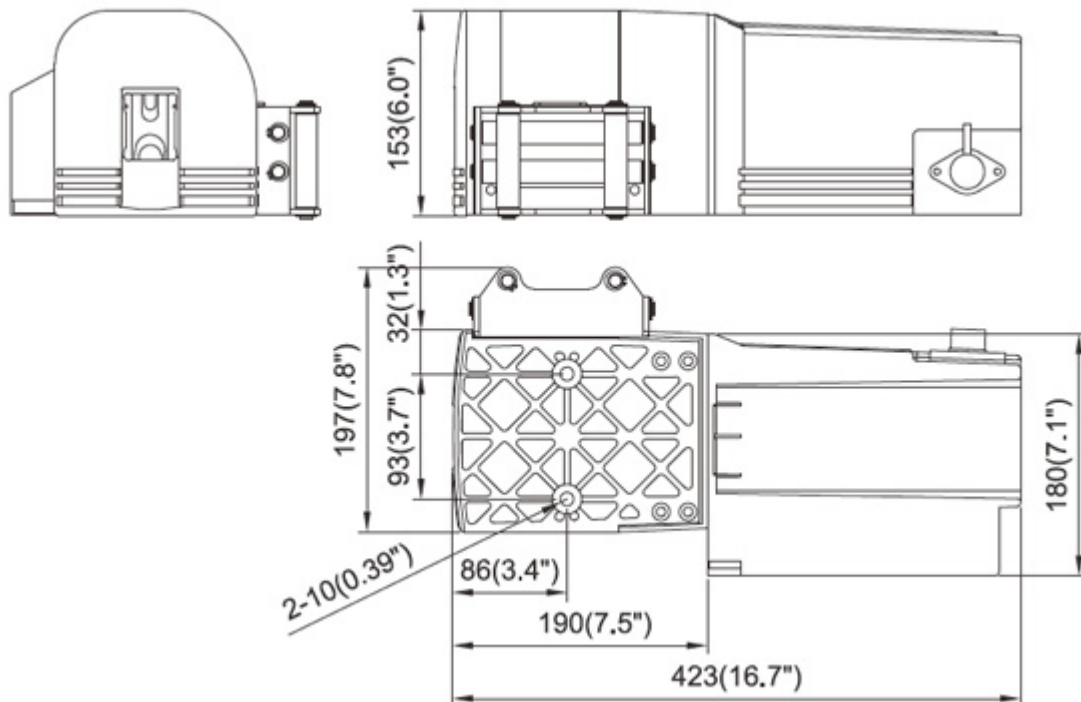

Packaging

- Winch weight (including rope) 14.2 kg
- Gross weight 18.2 kg
- Box dimension 470 x 280 x 200 mm

Accessories

- Wire rope w/safety hook
- Remote control 5m cord
- 1.5m 6 gauge battery lead
- Roller fairlead
- Circuit breakers
- Hand-saver strap
- Snatch block (OPTIONAL)
- Winch accessory kit (OPTIONAL)