

# GTD-1200

## 1200 lb (544kg) Heavy-Duty Hoist



PN 751321 12V  
PN 750375 24V

### Features Include

- Provides an answer to the health and safety recommendations for manual lifting.
- High efficient low amp. draw and sealed permanent magnet motor.
- Lightweight and compact design is ideal for small crane and davit applications.
- Mechanical spring applied and dynamic motor brake provide for precise load control.
- Waterproof industrial remote control with 5 m lead
- Full metal 3 stage planetary gear train, quiet, smooth and efficient.
- Submersible sealed contactor handles high amps and allows higher duty cycle.
- In compliance with standard of ANSI B30.5 for  $D/d \geq 18$  and rope safety factor  $\geq 3.5$

### Specifications

- Rated load: 1200 lb (544kg)
- Line speed (1st layer):

12 v	7.4 mpm	30 A @ no load
	5.5 mpm	130 A @ full load
24 v	5.9 mpm	15 A @ no load
	5.0 mpm	30 A @ full load
- Motor: 900 w / 1.2 hp 12 v / 24 v permanent magnet
- Gear ratio: 3-stage planetary 216:1
- Brake (outside the drum): Cone brake and dynamic motor
- Winch construction: Aluminum die-cast housings with steel drum.
- Drum size: 89 x 151 x 73 L
- Control: Remote control with 5 m lead
- Recommended Wire Rope: Galvanized aircraft A7 x 19
- Size: 4.8 mm x 18.3 m
- Mounting bolts pattern: 114 x 101.6 mm
- Standard Compliance: CE Machinery Directive 2006/42  
CE EMC Directive 2004/108/EC  
ANSI B30.5

## Line Pull and Rope Capacity

ROPE LAYER	PULL BY LAYER (KG / LB)	TOTAL ROPE ON DRUM (M)
1	544 / 1 200	4.2
2	494 / 1 089	8.8
3	452 / 996	13.8
4	416 / 917	18.3

LINE SPEED & AMP DRAW (1st Layer of Wire Rope on the Drum)						
LINE PULL	LINE SPEED (MPM)		AMP DRAW		% DUTY CYCLE	
	KG / LB	12V	24V	12V		24V
NO LOAD		7.4	5.9	30	15	2.5
136 / 300		6.9	5.7	55	19	2.3
272 / 600		6.4	5.5	75	25	2.0
408 / 900		5.9	5.2	95	36	1.8
544 / 1 200		5.5	5.0	130	50	1.5

## Dimensions mm/inch

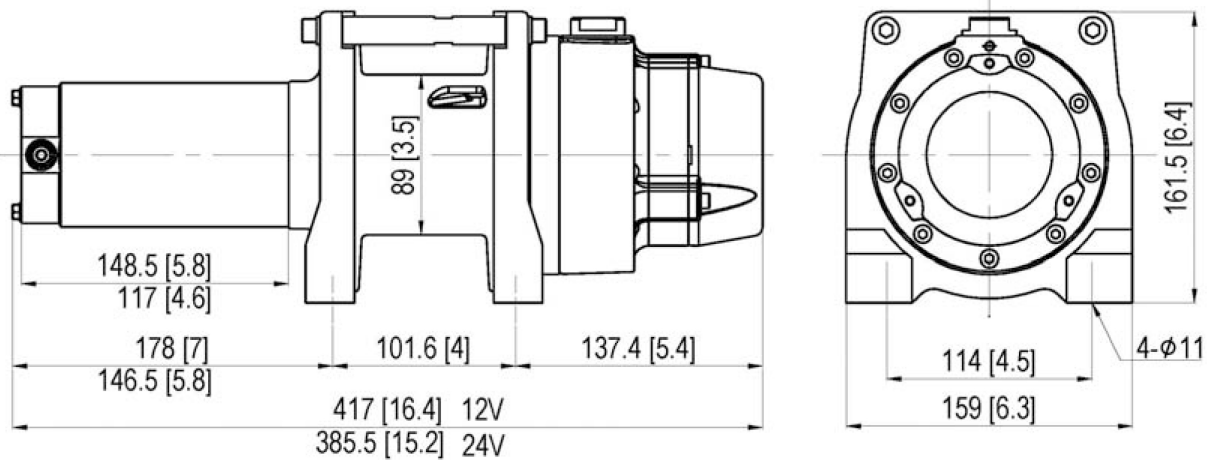

## Packaging

- Hoist Weight: 15.3 kg
- Gross Weight: 20.2 kg
- Box Dimensions: 504 x 214 x 363 mm

## Accessories

- Wire rope 4.8 mm x 18.3 m w/safety hook
- Remote control 5m cord
- Control box

## WARNING!

- Do not use hoist to transport, lift or otherwise move personnel.
- The rated line pull shown is based on the first layer of rope on the drum.
- The wire rope must remain on the drum at all times with at least 5 wraps.

## Warranty

Each new hoist is guaranteed against defects in workmanship and material defects for a period of 12 months from date of purchase.