

GTD-800

800 lb / 360kg Heavy-Duty Hoist



PN 750925 12V
PN 750955 24V

Features Include

- Provides an answer to the health and safety recommendations for manual lifting.
- Highly efficient low amp. draw and sealed permanent magnet motor.
- Lightweight and compact design is ideal for small cranes and davit applications.
- Spring applied and permanent motor dynamic brakes provide precise load control.
- Waterproof industrial remote control with 5 m lead.
- Full metal 3 stage planetary gear train is quiet, smooth and efficient.
- Submersible sealed contactor handles high amps and allows higher duty cycle.
- In compliance with standard of ANSI B30.5 for D/d \geq 18 and rope safety factor \geq 3.5

Specifications

- Rated load: 800 lb / 360kg
- Line speed (1st layer):
 - 12 v 3.6 m/m 20 A @ no load
 - 3.2 m/m 55 A @ full load
 - 24 v 4.3 m/m 15 A @ no load
 - 4.0 m/m 35 A @ full load
- Motor: 800 w / 1.0 hp 12 v / 24 v permanent magnet
- Gear ratio: 3-stage planetary 191:1
- Brake: Mechanical spring applied and dynamic motor
- Winch construction: Aluminum die-cast housings and drum.
- Drum size: 68 x 105 x 119 L
- Control: Remote control with 5 m lead
- Recommended Wire Rope: Galvanized aircraft A7 x 19
- Size: 4mm x 18.3m A7 x 19
- Mounting bolts pattern: 168 x 76 mm
- Standard Compliance: CE Machinery Directive 2006/42
CE EMC Directive 2004/108/EC
ANSIB30.5

Line Pull and Rope Capacity

| ROPE LAYER | PULL BY LAYER (KG / LB) | TOTAL ROPE ON DRUM (M) |
|------------|-------------------------|------------------------|
| 1 | 362 / 800 | 6.6 |
| 2 | 327 / 721 | 14.0 |
| 3 | 297 / 655 | 18.3 |

| LINE SPEED & AMP DRAW (1st Layer of Rope on the Drum) | | | | | |
|--|------------------|-----|----------|-----|--------------|
| LINE PULL KG / LB | LINE SPEED (MPM) | | AMP DRAW | | % DUTY CYCLE |
| | 12V | 24V | 12V | 24V | MIN / 10 MIN |
| NO LOAD | 3.6 | 4.2 | 20 | 15 | 3.0 |
| 181 / 400 | 3.4 | 4.1 | 40 | 25 | 2.0 |
| 362 / 800 | 3.2 | 4.0 | 55 | 35 | 1.5 |

Dimensions mm/inch

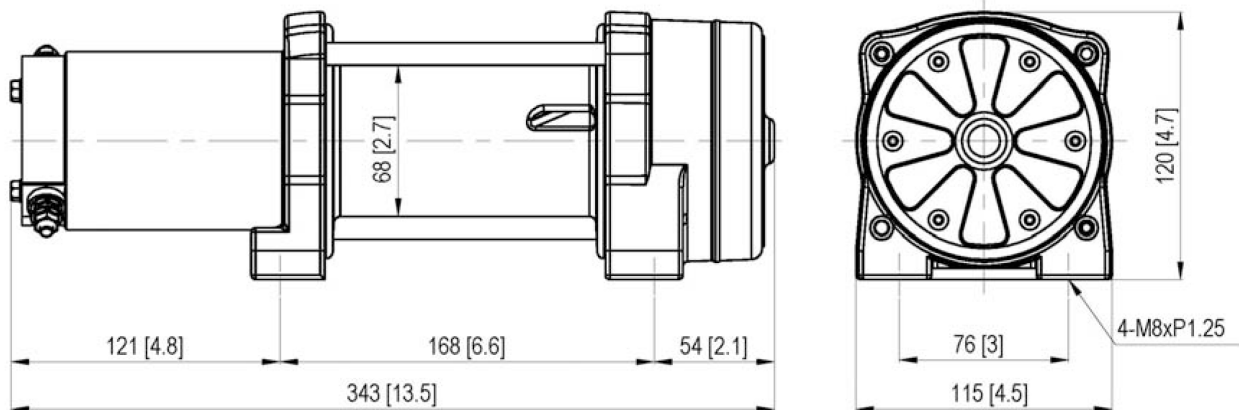

Packaging

- Hoist Weight: 8.3 kg
- Gross Weight: 12.2 kg
- Box Dimensions: 430 x 170 x 300 mm

Accessories

- Wire rope 4 mm x 18.3 m w/safety hook
- Remote control 5m cord
- Contactor box

WARNING!

- **Do not use hoist to transport, lift or otherwise move personnel.**
- **The rated load shown is based on the first layer of rope on the drum.**
- **The rope must remain on the drum at all times with at least 5 wraps.**

Warranty

Each new hoist is guaranteed against defects in workmanship and material defects for a period of 12 months from date of purchase.