

# DV-9

## 9000 lb Self-Recovery Winch



PN 856329 12V  
PN 856335 24V

### Features Include

- Robust and Reliable electric winch for commercial and recreational applications.
- 3430w / 12V or 1940w / 24V series wound motor.
- Free spool clutch with Stainless Steel T Handle can be rotated to suit various mounting arrangements.
- Hardened steel, 3-stage planetary gear train for efficient and reliable operation.
- Water-proof remote control with thermometric LED indicator alerts when the motor is over-heated.
- Mechanical cone brake holds the full load without slipping.
- Submersible sealed contactor handles high amps and allows higher duty cycle.
- Separate solenoid box can be remote mounted leaving a low profile winch ideal for discrete mounting.

### Specifications

- Rated line pull: 4082 kg single line.
- Line speed (1st layer):
  - 12v 13.4 m/m 55 A @ no load
  - 24v 13.4 m/m 30 A @ no load
  - 12v 2.0 m/m 350 A @ full load
  - 24v 2.0 m/m 210 A @ full load
- Motor:
  - 12v 3 430 w / 4.6 hp series wound
  - 24v 1 940 w / 2.6 hp series wound
- Gear ratio: 3-stage planetary 156:1
- Clutch (free-spooling): Rotating ring gear.
- Brake (outside the drum): Automatic, full load cone brake.
- Winch construction: Aluminum die-cast housings with steel drum.
- Drum size: 63.5 x 229 mm
- Control: Weather proof 5 m remote with thermometric indicator LED
- Wire Rope: Galvanized aircraft A7 x 19
- Size: 8.3 mm x 30.5 m
- Mounting bolts pattern: 254 x 114 mm

## Line Pull and Rope Capacity

ROPE LAYER	PULL BY LAYER (KG / LB)	TOTAL ROPE ON DRUM (M)
1	4 082 / 9 000	6.1
2	3 316 / 7 310	13.6
3	2 792 / 6 154	22.6
4	2 410 / 5 314	30.5

LINE SPEED & AMP DRAW (1st Layer of Wire Rope on the Drum)		
LINE PULL (KG / LB)	LINE SPEED (MPM)	AMP DRAW (12V)
No Load	13.4	55
907 / 2 000	4.6	110
1 814 / 4 000	3.4	200
2 722 / 6 000	2.7	230
3 629 / 8 000	2.3	260
4 082 / 9 000	2.0	350

## Dimensions mm/inch

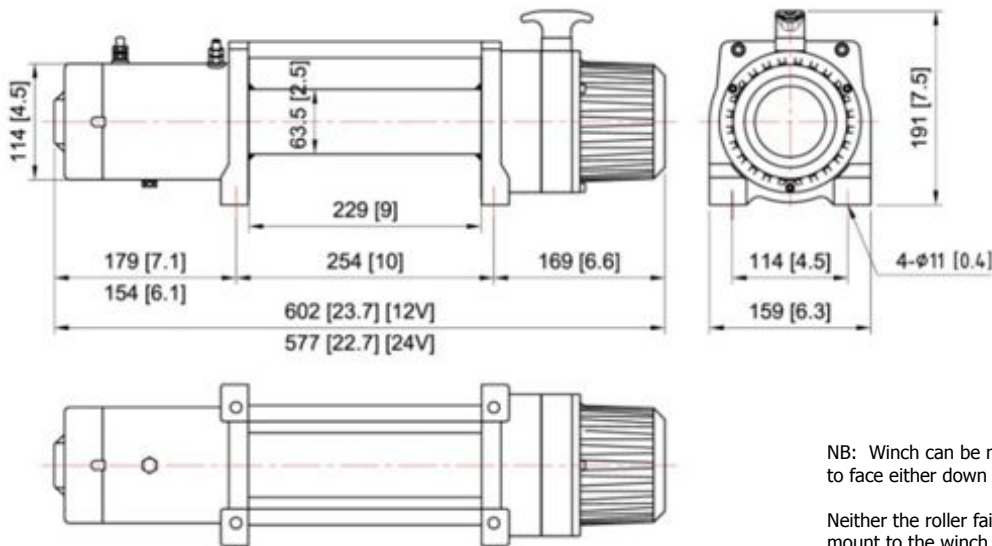

NB: Winch can be mounted with the feet orientated to face either down or forward.

Neither the roller fairlead or the solenoid enclosure mount to the winch.

## Packaging

- Winch Weight (including rope): 33 kg
- Gross Weight: 43 kg
- Box Dimensions: 650 x 192 x 415 mm

## Accessories

- Roller fairlead
- Remote control 5 m cord
- Detachable control box
- 1.8 m 2-gauge battery lead
- Wire rope w safety hook
- Hand-saver strap
- Mounting channel (OPTIONAL)
- Snatch block (OPTIONAL)
- Winch accessory kit (OPTIONAL)

## WARNING!

- Do not use winch to transport, lift or otherwise move personnel.
- The rated line pull shown is based on the first layer of wire rope on the drum.
- The wire rope must remain on the drum at all time with at least 5 wraps.

## Warranty

Limited lifetime warranty for mechanical components and one (1) year warranty for electrical components from date of purchase. Wire/Synthetic ropes are not included under warranty.