

# Cub 3

---

## 3 000 lbs Powersport Winch

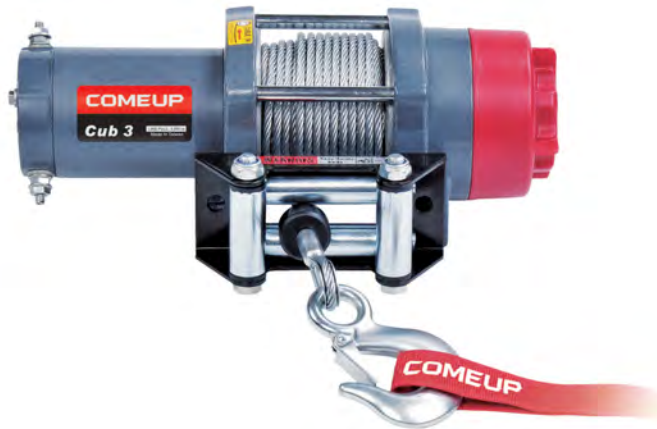

PN 123561 12V

### Features Include

---

- Sealed highly efficient low amp draw permanent magnet motor.
- Lightweight and compact design.
- Centre drum winch provides better support, handles side loading, increases strength and performance.
- Mechanical and dynamic brakes for 100% loadholding.
- Cam activated free spool clutch for rapid wire rope payout.
- Submersible, sealed contactor handles high amps and allows higher duty cycle.

### Specifications

---

- Rated line pull: 1361 kg (3 000 lb) single line.
- Line speed (1st layer): 6.8 mpm 20A at no load.  
2.0 mpm 230A at full load.
- Motor: 800 w / 1.0 hp 12V permanent magnet.
- Gear ratio: 3-stage planetary 138.5:1
- Clutch (free-spooling): Cam activated.
- Brake (outside the drum): Mechanical spring applied and dynamic brakes.
- Winch construction: Aluminum die-cast drum and steel plate housings.
- Drum size: 55 x 75 L
- Control: Handlebar rocker switch.
- Wire rope: Galvanised aircraft A7 x 19
- Size: 4.8 mm x 15.2 m
- Mounting bolts pattern: 124 mm x 76 mm
- Std Compliance: CE Machinery Directive 2006/42/EC  
CE EMC Directive 2004/108/EC

## Line Pull and Rope Capacity

### LINE SPEED & AMP DRAW

(1st Layer of Rope on the Drum)

ROPE LAYER	PULL BY LAYER (KG / LB)	TOTAL ROPE ON DRUM (M)
1	1 361 / 3 000	2.8
2	1 173 / 2 585	6.1
3	1 030 / 2 271	9.9
4	918 / 2 025	14.1
5	829 / 1 827	15.2

LINE PULL	LINE SPEED	AMP DRAW
KG / LB	MPM	12V
No Load	6.8	20
454 / 1 000	4.8	75
907 / 2 000	3.0	140
1361 / 3 000	2.0	230

## Dimensions mm/inch

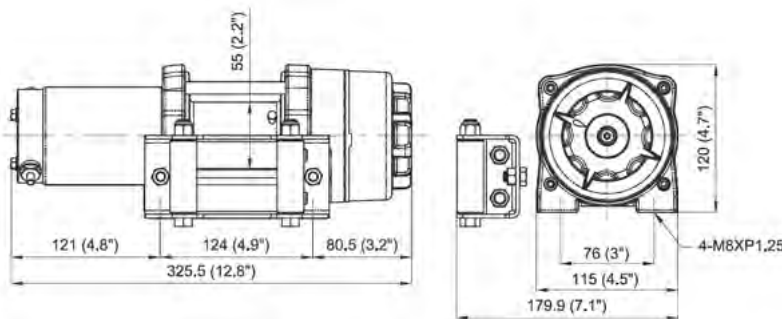

## Packaging

- Winch Weight: 8.2 kg
- Gross Weight: 12.5 kg
- Box Dimensions: 349 x 331 x 144 mm

## Accessories

- Wire rope 4.8 mm x 15.2 m w/safety hook
- Handlebar rocker switch kit
- Roller fairlead
- Detachable control box
- Mounting hardware
- Contactor pack

## WARNING!

- Do not use winch to transport, lift or otherwise move personnel.
- The rated line pull shown is based on the first layer of wire rope on the drum.
- The wire rope must remain on the drum at all time with at least 5 wraps.

## Warranty

Limited lifetime warranty for mechanical components and one(1) year warranty for electrical components from date of purchase. Wire/Synthetic ropes are not included under warranty.