

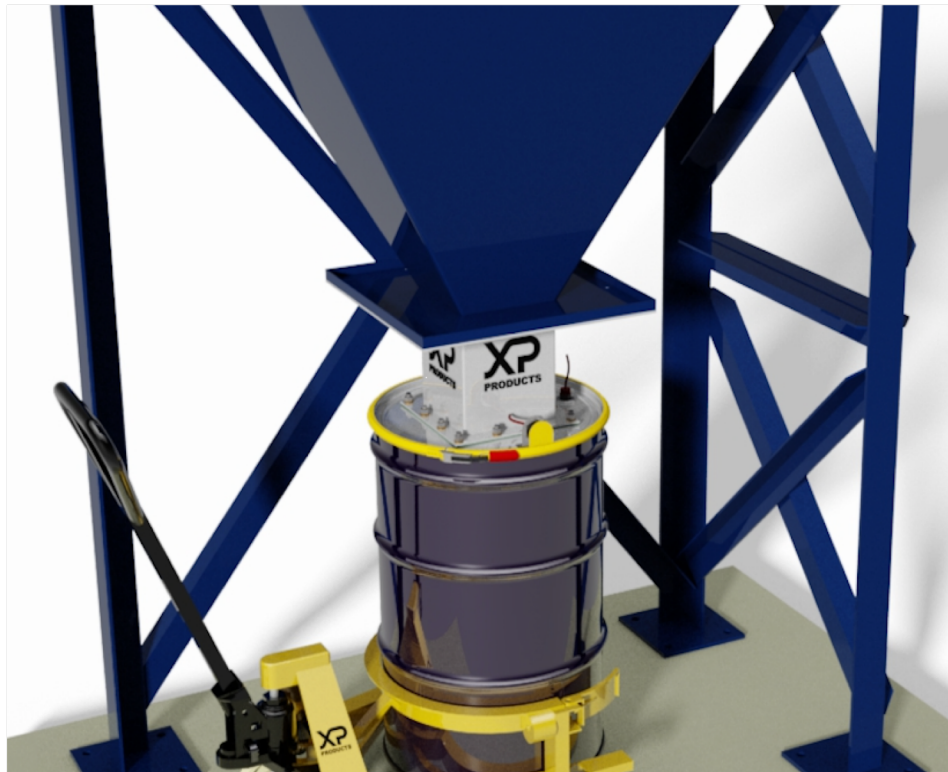



YOUR COMBUSTIBLE DUST MANAGEMENT PROFESSIONALS

2021 Update

INSTALLATION, OPERATION, AND MAINTENANCE
MANUAL
XP DRUM KIT



This manual is property of the owner. Leave with the XP Drum kit when set-up and start-up are complete. XP Products LLC reserves the right to change design and specifications without prior notice

 This is a safety alert symbol. It is used to alert you to potential personal injury hazards. Obey all safety messages that follow this symbol to avoid possible injury or death

 **WARNING** Process owners/operators have important responsibilities relating to combustible hazards. Process owners/operators must determine whether their process creates combustible dust, fume or mist. If combustible dust, fume, or mist is generated, process owners/operators should at a minimum:

- Comply with all applicable codes and standards. Among other considerations, current NFPA standards require owners/operators whose processes involve potentially combustible materials to have a current Hazard Analysis, which can serve as the foundation for their process hazard mitigation strategies.
- Prevent all ignition sources from entering any dust collection equipment
- Design, select, and implement fire and explosion mitigation, suppression, and isolation strategies that are appropriate for the risks associated with their application
- Develop and implement maintenance work practices to maintain a safe operating environment, ensuring that combustible dust, fume, or mist does not accumulate within the plant

XP Products recommends process owner/operators consult with experts to insure each of these responsibilities are met.

DO NOT operate this equipment until you have read and understand the instruction warnings in the Installation and Operations Manual.

 **DANGER** indicates a hazardous situation which, if not avoided, will result in death or serious injury

 **WARNING** indicates a hazardous situation which, if not avoided, could result in death or serious injury

 **CAUTION** indicates a hazardous situation which, if not avoided, could result in minor or moderate injury

NOTICE is used to address practices not related to personal injury that may result in damage to equipment

TABLE OF CONTENTS

INTENDED PURPOSE	4
EQUIPMENT DESCRIPTION	5
ATEX 2020 Certification Nameplate	5
END-USER OBLIGATION AND LIMITS OF APPLICABILITY	6
Design Requirements.....	6
Operability Requirements.....	6
Replacement Drum Requirements.....	6
INSTALLATION PROCEDURES	7
Inspection on Arrival.....	7
Installation.....	7
AVAILABLE OPTION	8
Drum In Place (DIP) Sensor.....	8
High Level (HL) Sensor.....	8
Gate Valve (Round and Square flange).....	9
HYDRAULIC DRUM LIFT OPERATION AND MAINTENANCE	11
Trouble Shooting.....	12
WIRING DIAGRAMS FOR DRUM IN PLACE AND HIGH LEVEL SENSORS	13
High Level Sensor Range.....	14
APPENDIX A- Sensor Specifications	15
High Level Sensor IFM OID 250.....	15
Drum In Place (DIP) Sensor IFM IIS 302.....	16
Warranty Statement	

Intended Purpose

The XP Drum Kit is an innovative alternative to traditional rotary valves for providing a means of explosion isolation. Our design provides an economical solution that improves ergonomics and reliability. The drum kit has been designed to collect/contain dust for dust collectors and acts as a strengthened extension of the dust collector. It is designed to withstand the reduced pressure (P_{red}) that develops during a properly vented or suppressed deflagration event. There are no moving parts that actuate or react upon detection of a pressure wave or thermal flux, therefore this device is not limited by a K_{St} value.

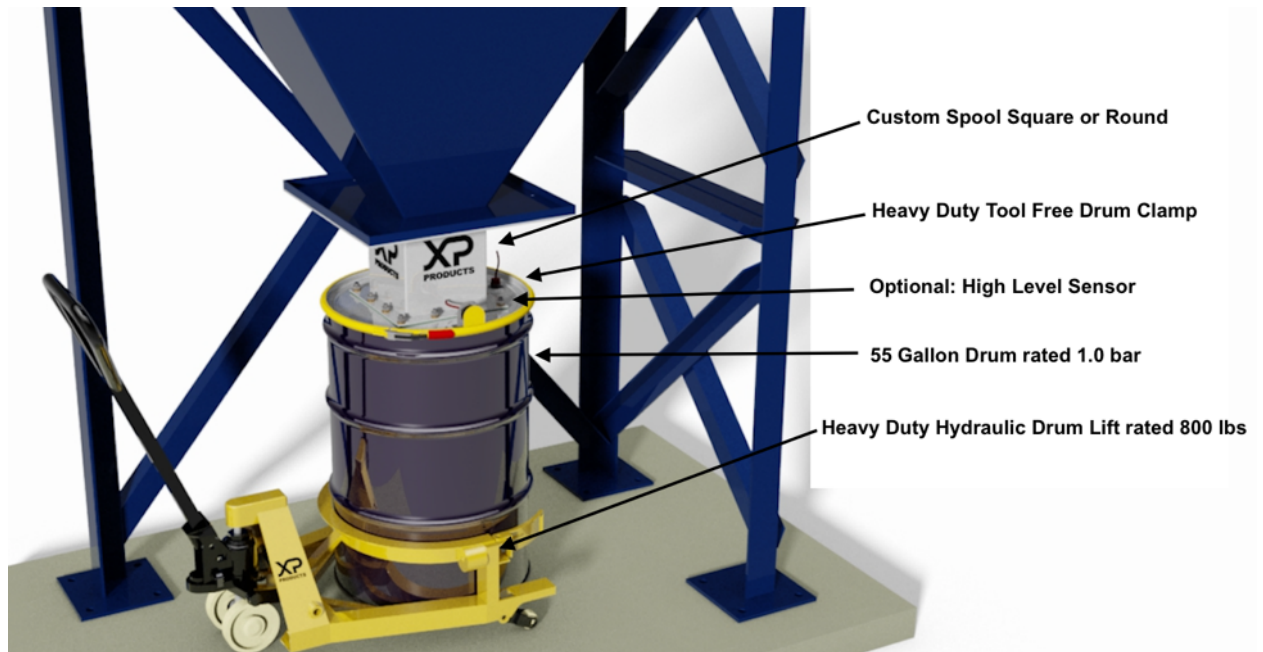

The XP Drum Kit has been third-party independently tested under flame and pressure conditions to establish a pressure rating of 1.0 bar. The test report is available for download on our website (www.xpproducts.com). This document demonstrates equivalency per NFPA 69 by providing the technical justification for the established pressure rating of this product.

The drum kit includes a spool piece that is custom fabricated to match the flange pattern of the discharge hopper on the dust collector and to provide the appropriate clearance between the discharge hopper and grade. The kit also includes a UN certified 55-gallon drum with a pressure rating of 100 kPa (1 bar) and a hydraulic drum lift with an 800 lb lift capacity.

WARNING

It is important to emphasize that this device is only effective when the proper design and installation of separate explosion mitigation equipment with the purpose of relieving or suppressing the pressure and flame effects that result from a deflagration event has been employed. By no means is this device designed to satisfy the pressure containment protections strategy specified in NFPA 69 which aims to contain the maximum pressure effects of a deflagration. The XP Drum Kit as designed to simply withstand pressures of 1.0 bar or less.

Equipment Description

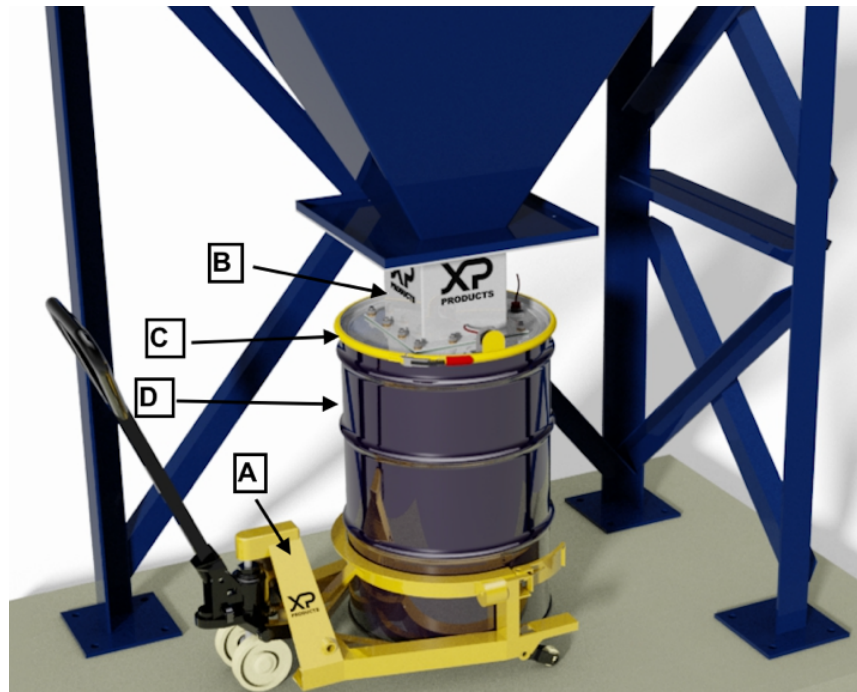

A. HYDRAULIC DRUM TRUCK/LIFTER:

Drum truck designed for use with 55-gallon steel drums with a lifting capacity of 800 lbs. The drum truck provides a safe and easy way to maneuver drums with a single operator. The drum hydraulic drum truck weighs 117 lbs.

B. HEAVY DUTY FLANGED SPOOL:

7-gauge square or round bolted flange to match dust collector outlet flange. 7-gauge square or round spool bolted and reinforced to drum lid.

C. DRUM COVER CLAMP AND DRUM LID:

Reinforced drum cover clamp with manual lever. EPDM rubber gasket seal around drum top perimeter.

D. HEAVY DUTY 55 GALLON STEEL DRUM:

Steel drum, exterior black painted. Capacity 425 kg. Shipping standard compliant UN1A2/Y1.2/100, UN 1A2/Y425/S. Drum is considered UN compliant for shipping.

ATEX Certification 2020

XP Products Naperville, IL 60540
xpproducts.com 630-464-3800

TYPE: XP-DK Serial Number: __-____
YEAR OF MANUFACTURING: _____



II 2D Ex h ExNB 20 ATEX 008
IIIC T120C Db

Test Pressure Rating: 0.9 bar
Power Requirement: 24 vdc
Ambient Temperature: -20 C to 50 C

End-User Obligations and Limits of Applicability

Design Requirements

The XP Drum Kit has a pressure rating of 1.0 bar and is only suitable for use for dust collectors with explosion mitigation systems that have been designed to limit the reduced pressure (P_{red}) to a value that is equal to or less than 1.0 bar. For typical applications, the drum kit adds an additional 0.25 m³ of volume that must be accounted for when sizing explosion relief vents or explosion suppression systems. For vented applications, the additional height the drum kit adds to the system must be considered to account for potential flame stretching effects. Please consult NFPA 68 for details on calculating minimum required explosion relief vent areas.

Operability Requirements

The XP Drum Kit includes a hydraulic lift that is used to raise the 55-gallon drum into place. The drum must be secured to the lid with the supplied lever locking clamp prior to operating the dust collector. The hydraulic drum lift should remain in place while the dust collector is in operation. The dust collector must be shut down prior to drum removal. An optional knife-gate valve is available to allow for drum changes during dust collector operation.

Operators should wear safety shoes and protective gloves when operating the hydraulic drum lift. To avoid tipping hazards, the drum lift should be used on a firm level surface and care must be taken not to overload the drum lift. This equipment should not be operated on a gradient greater than 2%. The drum lift should not be used as a lifting platform or step. Ensure hands and feet are not under the lift during operation and always check the work area for overhead obstructions and other possible hazards during operation.

Replacement Drum Requirements

The spool of the Drum Kit that connects directly to the hopper discharge flange can withstand fairly high-pressure due to its rugged construction. The weak point of the system is the drum itself therefore it is important to ensure replacement drums satisfy the pressure requirement for the system.

A UN certified drum is supplied with the XP Drum Kit. UN marked drums have a series of letters and numbers that specify the material of construction, type of drum, the packing class it can be used for, the material its designed to handle, etc. Most drums will have two numbers, one for its solid rating and one for its liquid rating. These numbers may look like UN1A2/Y425/S, UN1A2/Y1.2/100. The “UN” designation means that the drum has been tested and certified per CFR-178.60. The next three letters are the packaging identification codes. In this instance, 1A2 means the drum (1) is made from steel (A) and has an open head design (2). The next letter (Y) indicates the packing class the drum is appropriate for and is the same for both liquid and solid designations.

The next two numbers or number/letter combinations are of high importance for selecting appropriate replacement drums. For solids, a 425/S designation means the drum is rated to handle a maximum of 425 kilograms and is designed for use with solids (S). For liquids we see 1.2/100. This means that the drum is designed to handle liquids with a specific gravity of 1.2 or lower and that the drum has a pressure rating of 100 kPa (~14 psi). This pressure rating is the most important for selecting a proper replacement drum for the XP Drum Kits. XP Products provides a drum with the following UN designation: **UN1A2/Y1.2/100**

Replacement drums must be certified to handle pressures equal to or greater than 100 kPa.

Installation Procedures

The drum kit is shipped assembled. Carefully remove packaging material and unload the drum kit off the pallet. Check to ensure no bolts have loosened during transport.

Inspection on Arrival

1. Inspect XP Products Drum Kit upon arrival
2. Report any damage to the delivery carrier
3. Request a written inspection report form the Claims Inspector to substantiate any damage claim
4. Compare collector received with description of product ordered
5. Report incomplete shipments to the delivery carrier and your XP Products representative
6. Remove shipping pallets, and straps. Remove loose components and accessories before lifting drum kit from truck
7. Check for hardware that may have loosened during shipping
8. Use caution removing temporary covers

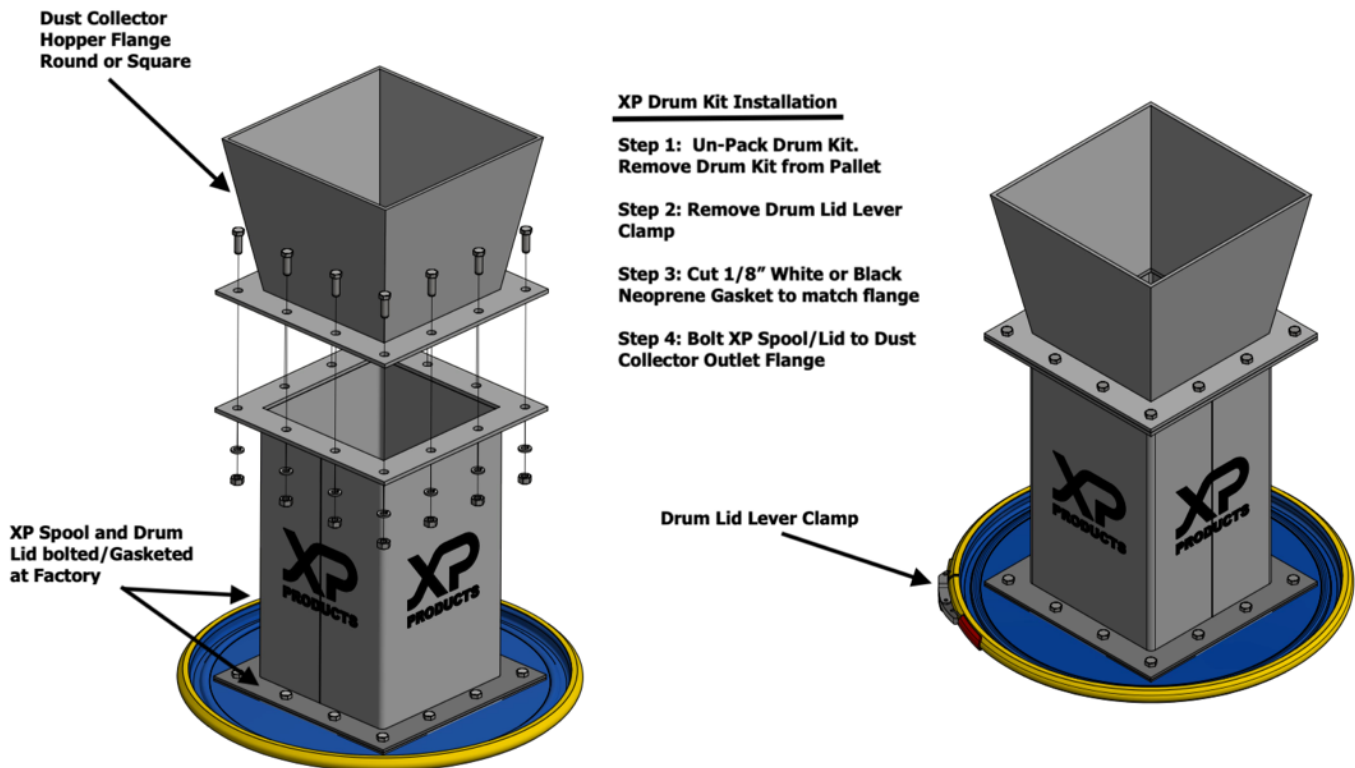

Installation

1. Use the hydraulic drum lift to position drum kit below the discharge hopper.
2. Place the included gasket (can be found inside the drum) on top of the dust collector mating flange.

3. Use the hydraulic drum lift to lift the drum kit into place. Ensure the bolt pattern on the dust collector mating flange lines up with the bolt pattern on the dust collector discharge hopper.
4. Secure the drum kit to the dust collector discharge flange using appropriate bolts (hardware supplied by end-user). **See above install diagram**
5. Wire proximity switches as required. Wiring diagrams for optional Drum-in-Place and Hi-Level proximity switches are shown below.

AVAILABLE OPTIONS



1. Drum in Place Sensor – Technical Specifications Appendix A



IIS302
PROX. SENSOR

2. High Level Sensor – Technical Specifications Appendix A

OID250 DISCRETE
DISTANCE SENSOR
(PNP)



3. Gate Valve (6", 8", 10" and 12") Round or Square Flange Pattern

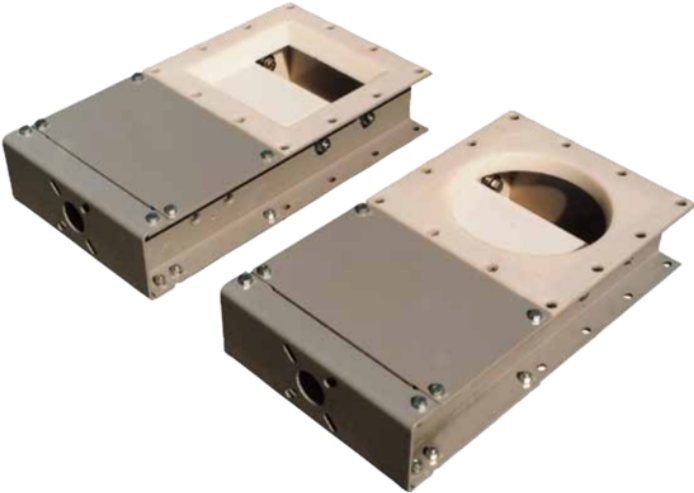

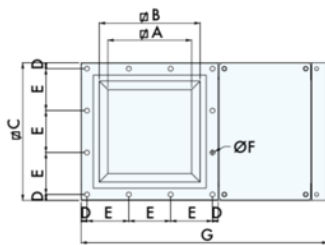

Square Cross Section Valves
 Schieber mit quadratischem Querschnitt
 Vannes à Section Carrée
 Valvole con Sezione Quadrata



TYPE	A	B	C	D	E	N°E	Ø F	Bolts Schrauben Boulons Bulloni	G	H	kg
VLQ0150..	120	175	261	15,5	115,0	2	12,5	M10	455	113	14
VLQ0200..	170	225	311	15,5	93,3	3	12,5	M10	555	113	18
VLQ0250..	220	275	361	15,5	110,0	3	12,5	M10	650	113	22
VLQ0300..	270	325	431	23,0	128,3	3	12,5	M10	765	113	30
VLQ0350..	320	375	481	18,0	89,0	5	12,5	M10	900	125	40
VLQ0400..	370	425	531	15,5	100,0	5	12,5	M10	1.000	125	46

- 1 Carbon Steel / Stahl / Acier au carbone / Acciaio al carbonio
- 3 304 Stainless Steel / Edelstahl 1.4301 / Acier inox 304 / Acciaio inox AISI 304

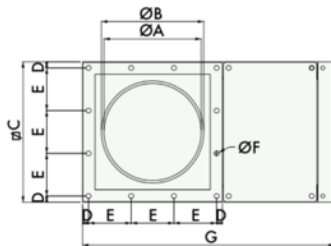

Round Cross Section Valves
 Schieber mit rundem Querschnitt
 Vannes à Section Circulaire
 Valvole a Sezione Circolare



TYPE	A	Ø B	Ø C	D	E	N°E	Ø F	Screw Schrauben Boulons Bulloni	G	H	kg
VLC0150..	150	165	261	15,5	115,0	2	12,5	M10	455	113	14
VLC0200..	200	215	311	15,5	93,3	3	12,5	M10	555	113	18
VLC0250..	250	265	361	15,5	110,0	3	12,5	M10	650	113	22
VLC0300..	300	315	431	23,0	128,3	3	12,5	M10	765	113	30
VLC0350..	350	365	481	18,0	89,0	5	12,5	M10	900	125	40
VLC0400..	400	415	531	15,5	100,0	5	12,5	M10	1.000	125	46

- 1 Carbon Steel / Stahl / Acier au carbone / Acciaio al carbonio
- 3 304 Stainless Steel / Edelstahl 1.4301 / Acier inox 304 / Acciaio inox AISI 304



8" x 8" Square Gate with Manual Actuator

Hydraulic Drum Lift Operation and Maintenance

The hydraulic drum lift is supplied to support the drum kit while the dust collector is in operation and to improve the ergonomics of removing and changing the drums.

WARNING

The dust collector must be shutdown prior to changing drums unless a slide gate is provided to isolate the collector from the drum during change out.

The lever on the hydraulic drum lift has three positions; Lower, Neutral, Ascent. These lever positions are illustrated in the following figure.

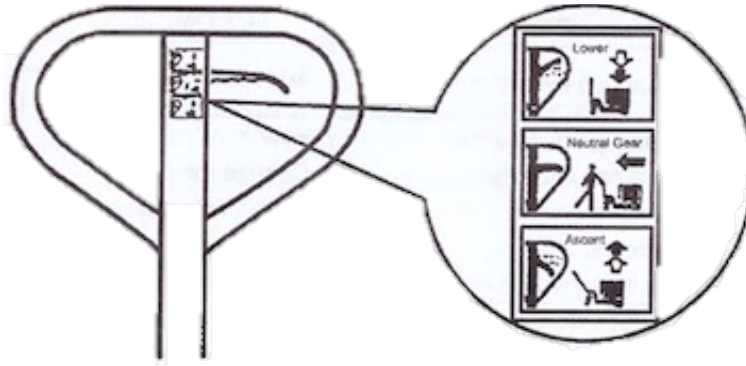

The “Lower” position is used to lower the lift and release the drum, the “Neutral” position is used to move the load, and the “Ascent” position is used to grab and lift the drum.

To lower and release the drum, pull the lever back towards the handle. The lift will lower until the drum is resting on the ground. Continue holding the lever to open the holding claw. This will release the drum.

To load a drum, the holding claw must be in the open position. Wheel the drum lift into position. Push the lever away from the handle into the ascent position. Move the handle up and down to close the holding claw and lift the drum to the desired height.

To move the drum, place the lever in the neutral position and use the handle to steer the drum and drum lift to the desired location.

⚠ CAUTION Operators should wear safety shoes and protective gloves when operating the hydraulic drum lift. To avoid tipping hazards, the drum lift should be used on a firm level surface and care must be taken not to overload the drum lift. This equipment should not be operated on a gradient greater than 2%.

Trouble Shooting Tips

The following table provides trouble shooting tips for the hydraulic drum lift.

	Trouble	Cause	Action
1	The forks do not lift to max height	-Not enough hydraulic oil	-Add more oil
2	The forks do not lift up	-Not enough hydraulic oil -Air in hydraulic oil -Discharge valve needs adjustment	-Add more oil -Change the oil -Adjust setting screw 140H
3	The forks do not descend	-Rod 102 and cylinder 159H are deformed -Unbalanced load -Setting screw 140H in wrong position	-Replace rod 102 and cylinder 159H -Adjust load -Adjust setting screw 140H
4	Leaking Oil	-Seals worn or damaged -Check for cracked parts	-Replace seals or damaged parts
5	The forks descend without being lowered	-Air in the oil -Seals are worn -Valve B is not adjusted	-Expel the air and change oil -Replace seals -Adjust setting screw
6	The handle will not hold position	-Hydraulic leak -Damaged seals	-Check hydraulics -Replace seals

Wiring Diagrams for Drum In Place DIP302 and High Level HL250

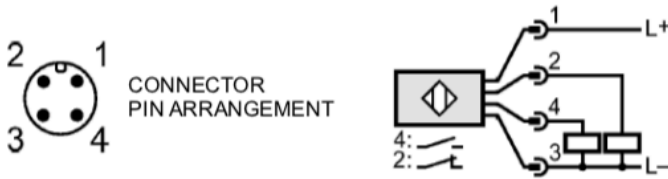

IFP
OID250 DISCRETE
DISTANCE SENSOR
(PNP)

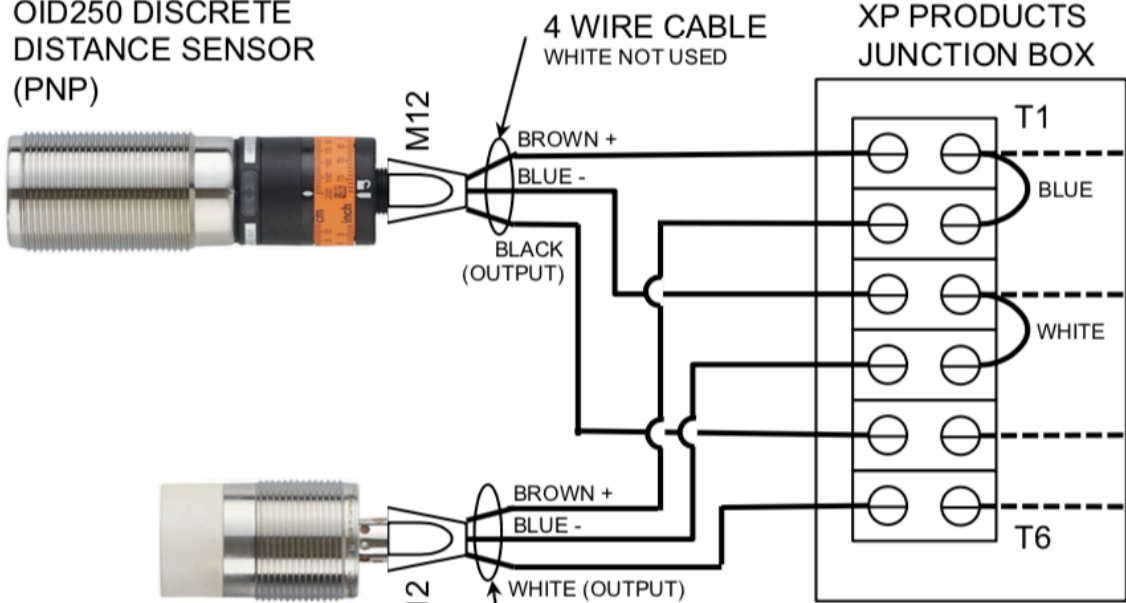

IFP
IIS302
PROX. SENSOR
(PNP)

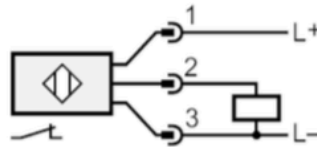
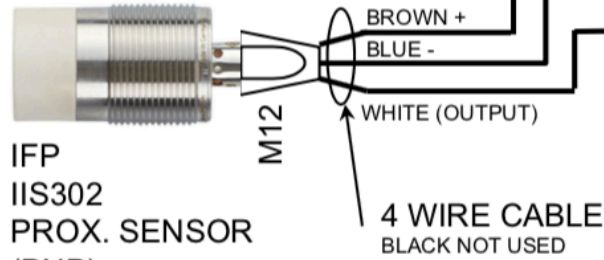

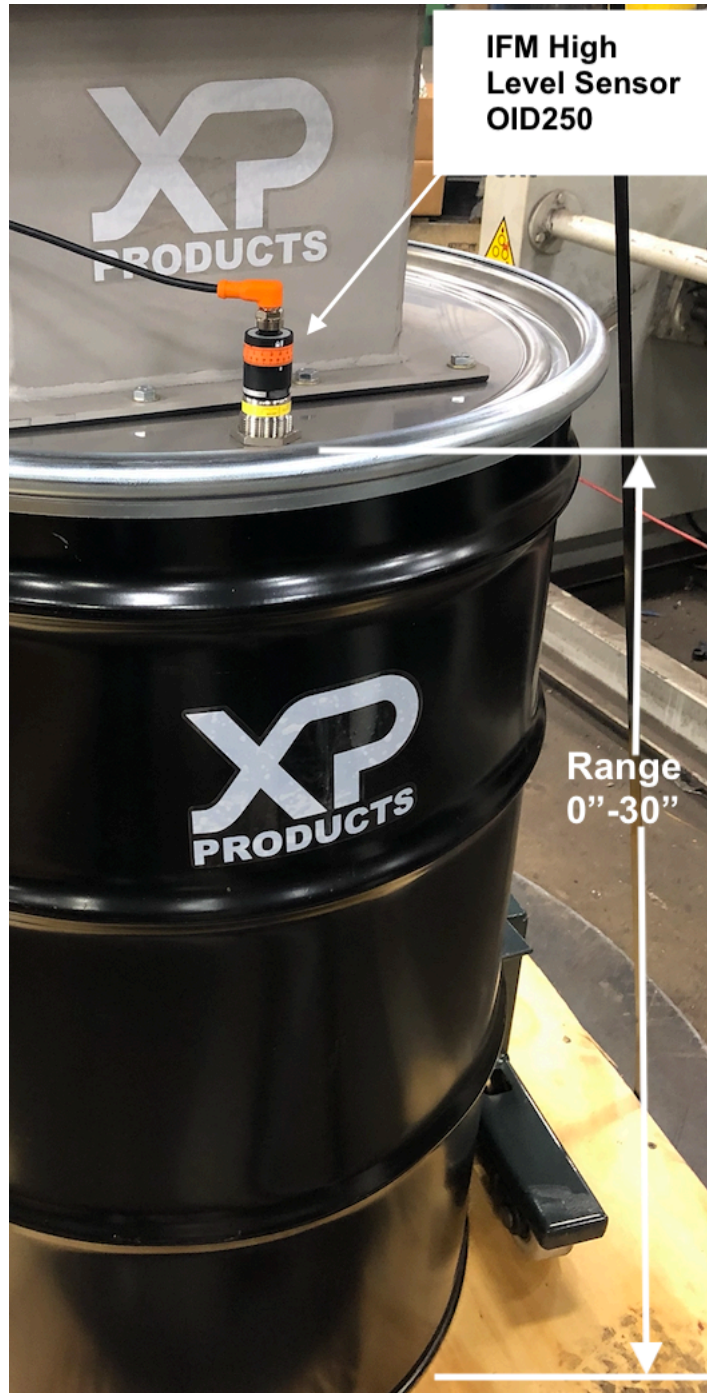

APPENDIX A- Sensor Technical Specifications

High Level Sensor IFM OID250

efector200



OID250

OIDLCPKG/US

Photoelectric sensors

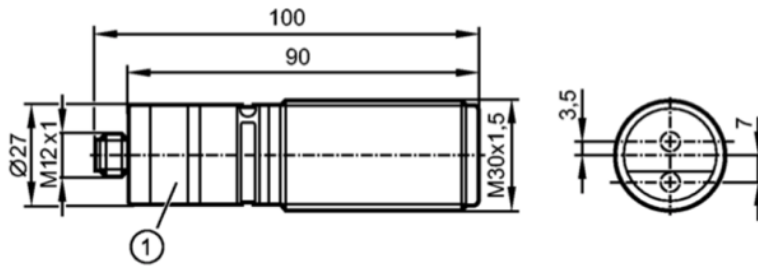

1: setting ring



Product characteristics

Photoelectric distance sensor

Connector

Background suppression

Visible laser light, LASER CLASS 1

setting ring

manually adjustable [cm/inch]

Measuring range 0.03...2 m

Background suppression ...20 m

Electrical data

Electrical design	DC PNP
Operating voltage [V]	10...30 DC; "supply class 2" to cULus.
Current consumption [mA]	75 (24 V)
Life expectancy typ. [h]	50000
Type of light	Red light 650 nm
Protection class	III
Reverse polarity protection	yes

Outputs

Output function	2 switching outputs normally open / closed complementary
Current rating [mA]	2 x 100
Short-circuit protection	pulsed
Overload protection	yes
Switching frequency [Hz]	11

Range

Background suppression	...20 m
Light spot diameter [mm]	< 5 (Range 2 m)
Hysteresis [%]	< 4; black (6 % remission) at max. range

Hysteresis graph

x: distance in [mm]
y: Hysteresis in [mm]

Drum In Place Sensor DIP M30



EZProx Proximity Sensors

XP Drum In Place Sensor DIP M30 Flush

EZ Prox Selection Guide and Specifications

Specifications	M8		M12		M18		M30	
Type	Flush	Non Flush	Flush	Non Flush	Flush	Non Flush	Flush	Non Flush
Housing Construction	Stainless Steel SS304		Nickel Plated Brass or Stainless Steel SS304 (Double sense only in Stainless Steel SS304)					
Sensing Distance (Standard)	2.0mm (0.079in)	2.5mm (0.098in)	2.5mm (0.098in)	4.0mm (0.157in)	5.0mm (0.196in)	8.0mm (0.315in)	10.0mm (0.393in)	15.0mm (0.590in)
Sensing Distance (Double Sense)	4.0mm (0.157in)	6.0mm (0.236in)	6.0mm (0.236in)	10.0mm (0.393in)	12.0mm (0.472in)	18.0mm (0.709in)	20mm (.787in)	30mm (1.18in)
Switching Frequency	1000 Hz		2000 Hz		600 Hz		200 Hz	
Metal Sensing Material Factor	Steel Type FE 360 - S(n) x 1.00, Brass - S(n) x 0.64, Aluminum - S(n) x 0.55, Copper - S(n) x 0.51, Stainless Steel (V2A) - S(n) x 0.85							
Differential Hysteresis	2-10%							
Repeat Accuracy	Better than 2% of sensing distance							
Supply Voltage	10-30VDC with <10% ripple							
No Load Supply Current	≤20mA							
Load Current	Maximum 100mA		Maximum 200mA				Maximum 400mA	
Leakage Current	≤10µA							
Voltage Drop	1.2 volts maximum							
Output Logic	PNP sourcing transistor or NPN sinking transistor "ON" when target within sensing range, "OFF" if no target, for NO models. Reverse logic for NC models							
Light Ring Indicators	LED Light Ring Indicator turns ON when output transistor is ON							
Time delay before availability (tv)	100ms maximum							
Power & Output Voltage Protection	Reverse polarity protection for power, Short-circuit protection for output with automatic recovery and transient voltage protection for output for typical inductive load							
Operating Temperature / Drift	-25° to +70° C (-13° to 158° F), Drift of sensing range <10%							
Tightening Torque	4 Nm (2.95 lb-ft)		10 Nm (7.37 lb-ft)		35.0 Nm (25.8 lb-ft)		50.0 Nm (36.8 lb-ft)	
Protection Degree	IEC IP 67, NEMA 6P							
Agency Approvals	cUL, UL pending							
Sensing Face materials	PBT							

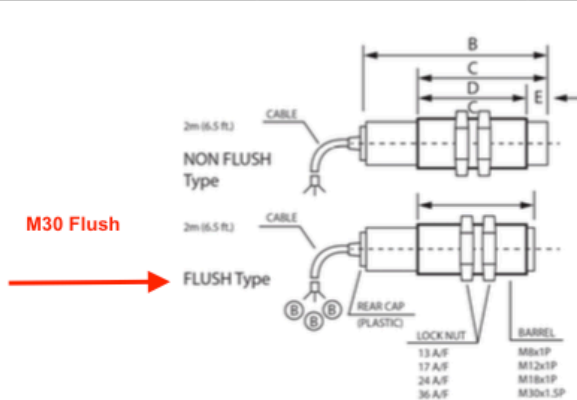

* All dimensions in mm, NB-Nickel Brass, SS-Stainless Steel, TS-Triple Sense Stainless Steel

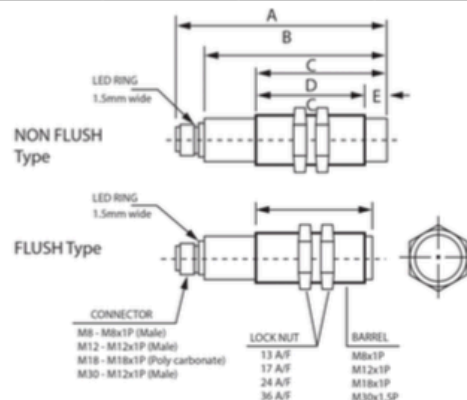

* All dimensions in mm, NB-Nickel Brass, SS-Stainless Steel, TS-Triple Sense Stainless Steel

Sizes	B	C	D	E
M8, NB, SS or TS	50	50	45	5
M12, NB or SS	50	38	33	5
M12, TS Flush	50	38	-	-
M12, TS Non Flush	53	41	33	8
M18, NB or SS	50	38	30	8
M18, TS Flush	50	38	-	-
M18, TS Non Flush	54	42	30	12
M30, NB or SS	60	48	33	15

Sizes	A	B	C	D	E
M8, NB, SS or TS	60	50	50	45	5
M12, NB or SS	60	50	38	33	5
M12, TS Flush	60	50	38	-	-
M12, TS Non Flush	63	53	41	33	8
M18, NB or SS	60	46	34	26	8
M18, TS Flush	60	48	34	-	-
M18, TS Non Flush	64	50	38	26	12
M30, NB or SS	65	51	39	24	15

SPARE PARTS LIST (October 2019)

Description	Part Number	Qty	Price
Drum In Place DIP Sensor 10-30 V DC	EZ-M30-PNPNO-FMW-TS	1	\$205.00
High Level Sensor 24 V DC	Efector 200 OID 250	1	\$356.00
High Level Cable Assembly (4) Wire	Efector EVC004	1	\$34.00
Heavy Duty 55 Gallon Drum CQ5508Q	UN Solid 1 A2/X430/S	1	\$291.00
Drum Lid Gasket Black EPDM	GE5500	1	\$28.50
Hydraulic Drum Lift Truck 800 lb	HJ365 Color RAL 1028	1	\$978.00
Gate Valve rated 0.3 Bar 8",10",12"	call	1	call

WARRANTY STATEMENT

XP Products warrants XP Drum Kit for a period of 12 months from initial start-up or 18 months from date of shipment, whichever is less, that products manufactured by XP Products covered by Buyer's order

(1) are free from defects in material and manufacture and (2) have the capacities and ratings set forth in XP's OEM manual (the "Warranty.") Exclusions from this Warranty include damage or failure arising from: wear and tear; corrosion, erosion, or deterioration; Buyer's failure to follow the XP OEM manual; modifications made by others to XP's equipment. XP Products shall not be obligated to pay for the cost of lost lubricant. XP Products obligations and liabilities under this Warranty are limited to furnishing replacement equipment or parts, at its option, f.o.b. factory or warehouse at XP-designated shipping point, for all non-conforming XP manufactured products which have been returned by Buyer to XP Products. Returns must have prior written approval by XP Products and are subject to restocking charge where applicable. XP PRODUCTS MAKES NO REPRESENTATION OR WARRANTY, EXPRESS OR IMPLIED, REGARDING MISUSE, DRUM CAPACITY, LIFT MALFUNCTION, OR ANY OPERATOR MISUSE.

No liability whatever shall attach to XP Products until products have been paid for and XP's

liability under this Warranty shall be limited to the purchase price of the equipment shown to be defective. Further warranty protection is available on an extra-cost basis. Any further warranty must be in writing and agreed to by an authorized signatory of XP Products.

THIS WARRANTY IS GIVEN IN LIEU OF ALL OTHER WARRANTIES, EXPRESS OR IMPLIED, INCLUDING IMPLIED WARRANTIES OF MERCHANTABILITY AND FITNESS FOR A PARTICULAR PURPOSE AND/OR OTHERS ARISING FROM COURSE OF DEALING OR TRADE. IN NO EVENT SHALL XP Products BE LIABLE FOR ANY INCIDENTAL