



EXPLOSION PROOF DRUM KIT

DATASHEET XPDK1901

PASSIVE SOLUTION

The XP Drum Kit is a truly passive solution that is designed to contain the effects from an explosion in a properly vented or suppressed dust collector or cyclone.

SAFE AND ERGONOMIC

The 800lb capacity Hydraulic Lift allows safe removal of the drum, reducing risk of injury or spills. The ergonomic design of the XP drum kit makes changing barrels a simplistic maneuver.

ECONOMICAL

The low installation and maintenance costs combined with the time savings of quick drum change out equates to more money in your pocket.

- Half the Cost of Rotary Valve
- No moving Parts
- No Maintenance
- Low Operation Costs

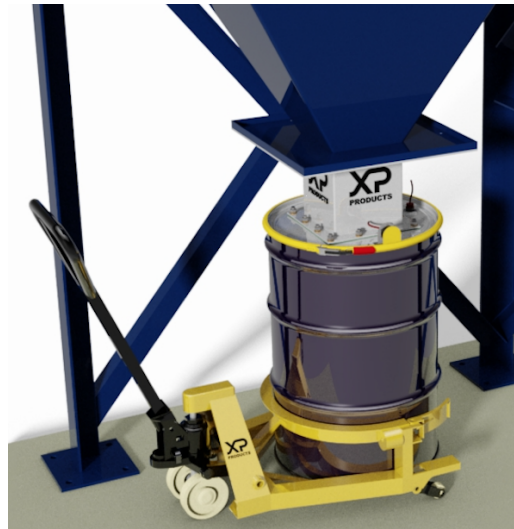

Drum Level Sensor 0-100% Adjustable. 0-30 vdc

Drum In Place Proximity Sensor (DIP) 0-30 vdc



XP DRUM KIT

The XP Drum Kit is an innovative replacement to traditional rotary valves. The XP Drum Kit has been 3rd party tested using a ST1 dust, $P_{max} = 7.6$ bar. **The XP Drum Kit has been tested and rated 14.5 psig!**

The NFPA Drum Kit Acts as a strengthened extension of the dust collector. It is designed to withstand the reduced pressure (P_{red}) that develops during a properly vented deflagration event, and is not limited by K_{st} value.

OPTIONS

- Drum Level Sensor 1-100%
- 304 SS Food Grade
- Drum in Place (DIP) Sensor
- Gate Valves 6" - 14" Sizes
- "Mini" Drum Kits for 20"-40" clearances

SPECIFICATIONS

- Drum Kit Rated to 1.0 bar
- 800lb Lift Capacity
- Outdoor Temperatures -20F to 115F
- Heavy Duty Design
- Complete Grounding and Bonding



YOUR COMBUSTIBLE DUST MANAGEMENT PROFESSIONALS

engineering@xpproducts.com | 630-464-3800 | www.xpproducts.com

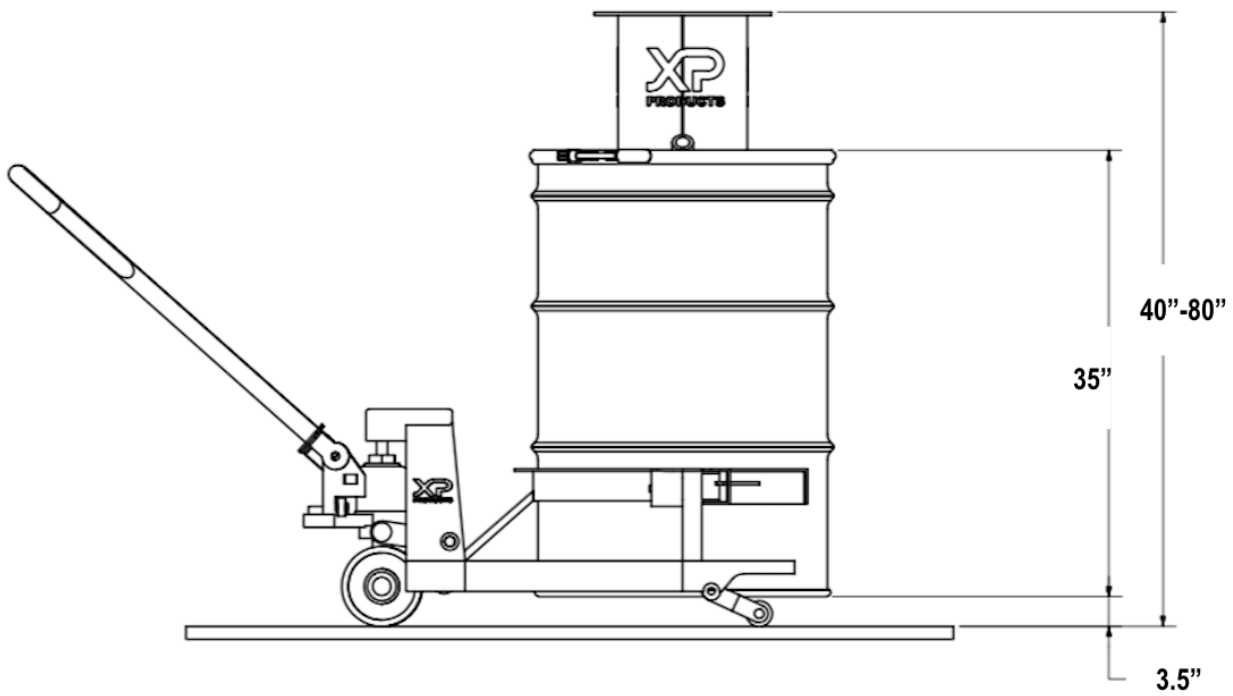

Elevation

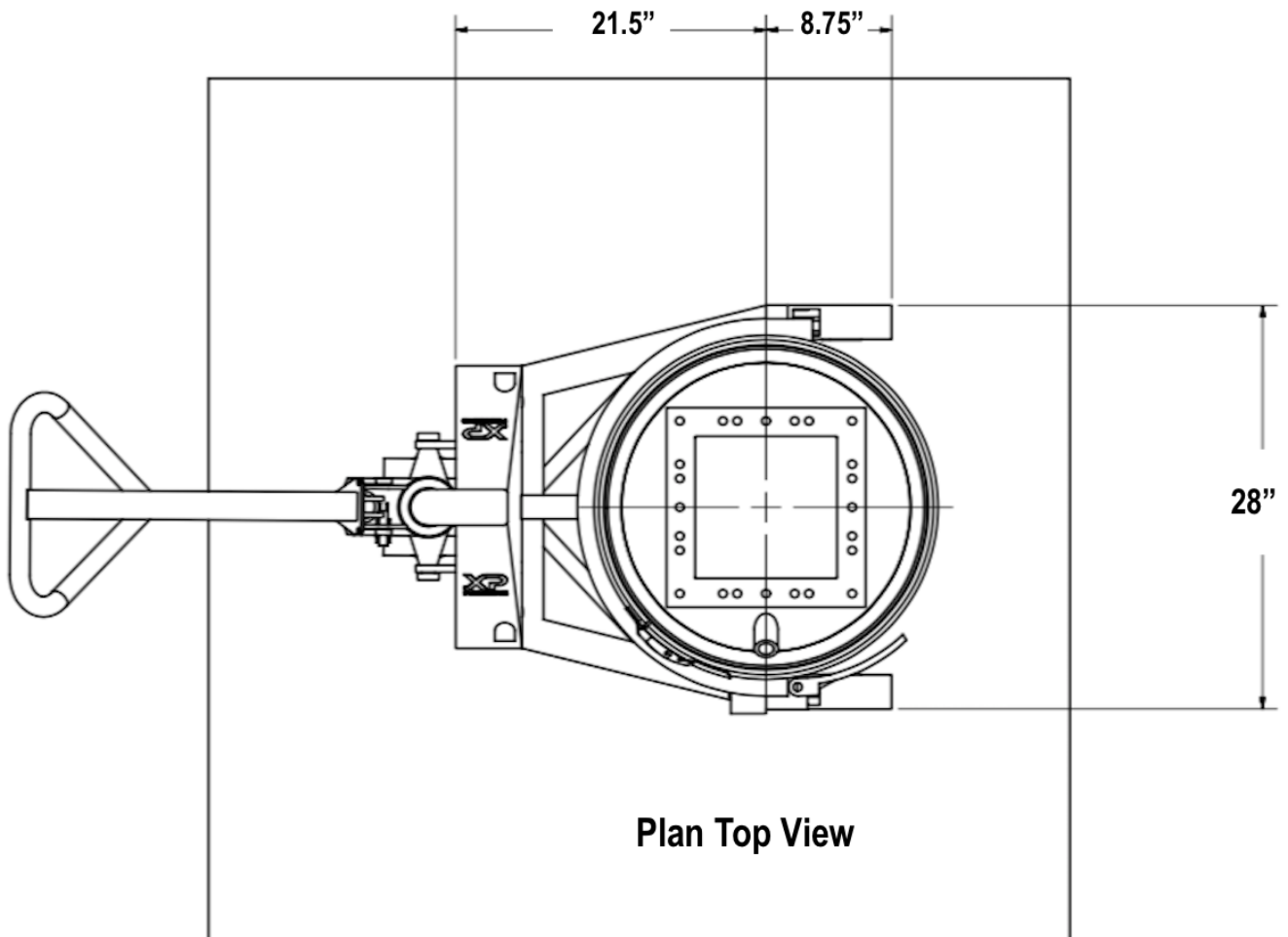

Plan Top View