



OMNTEC

Advanced Tank Monitoring & Leak Detection



1. Open the camera app
2. Focus the camera on the QR code by gently tapping the code
3. Follow the instructions on the screen to view PDF file

L1PD2-12VDC INSTALLATION GUIDE

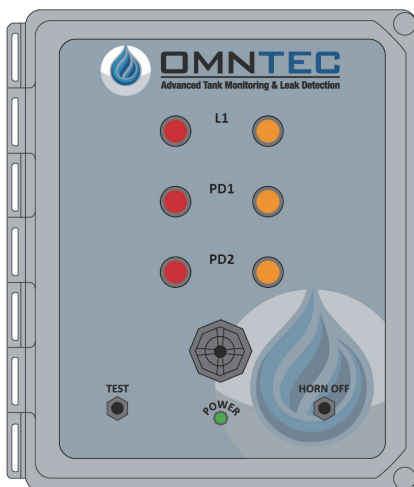

THREE CHANNEL ALARM PANEL

Revision 2410

Document No. L1PD2-12VDC

TABLE OF CONTENTS

L1PD2-12VDC SPECIFICATION	3
DIMENSIONS FOR MOUNTING AND KNOCKOUTS	4
LPD-SERIES INSTALLATION INSTRUCTIONS	5
L1PD2-12VDC CONTROLLER CONNECTION DIAGRAM	9
PDS SENSOR	10
PDWF SENSOR	11
PDWS SENSOR	12
L-1 SENSOR.....	13
L-2 SENSOR.....	14
L-R-1 SENSOR.....	15
LPD SERIES SYSTEM OPERATION AND TEST INSTRUCTIONS	17
L1PD2 CONTROL DRAWING.....	18
RA-SERIES REMOTE HIGH-LEVEL ALARM	19
LOG SHEET	20
WARRANTY	21

L1PD2-12VDC

THREE CHANNEL ALARM PANEL

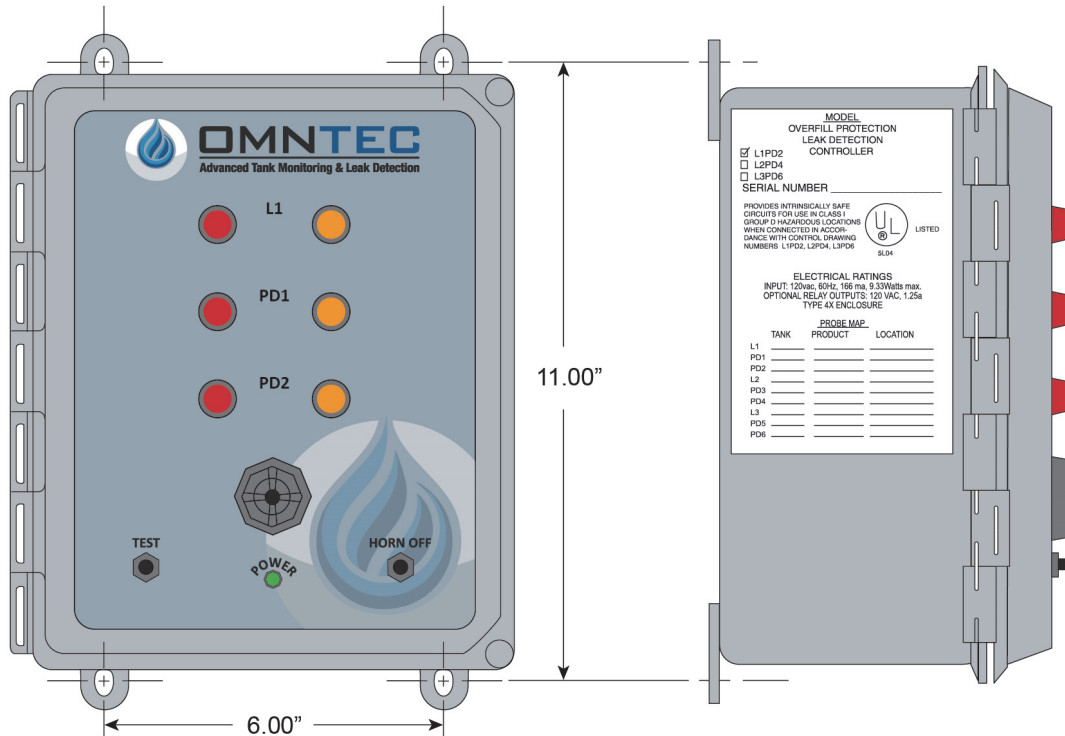

L1PD2-12VDC SPECIFICATION

POWER INPUT

12 VDC

POWER TO SENSORS

2 VDC @ 13 mA

RELAY OUTPUT

SPST normally open dry contacts 0.5 AMPS, 120 AC switches when an alarm condition occurs

WEIGHT

6 LBS.

DIMENSIONS

(W) 9" x (H) 10.5"

SENSOR CABLE

Shielded 22 AWG UL-E118830 CM
Maximum length 2000 feet

ENCLOSURE

NEMA 4X

OPERATING TEMPERATURE

-40° to 140° F

UL LISTED

Intrinsically safe circuits for use in class I group D hazardous locations when connected in accordance with control drawings L1PD2

AUDIO/VISUAL CONSOLE

AUDIBLE ALARM - 95 dB pulsing horn with 30 second timeout

RED LIGHT - Indicates either liquid alarm for L-Series sensor or product alarm for PD-Series sensor

AMBER LIGHT - Indicates either low level alarm for L-2 Series sensor or water alarm for PD-Series sensor

TEST BUTTON - When pressed will test system lights and horn

GREEN LIGHT - Indicates the power is on

HORN OFF BUTTON - Silences the audible alarm when pressed

SENSORS

- L-1 High level optic sensor
- L-2 Dual level high/low liquid optic sensor
- PD-Series Product distinguishing liquid optic sensor
- L-R-1 Reservoir sensor

OPTIONAL ACCESSORIES

- RA-Series Audio/visual remote annunciator
- RLY-RA External relay box series

LABELS

Provided with controller

L1PD2-12VDC

DIMENSIONS FOR MOUNTING AND KNOCKOUTS

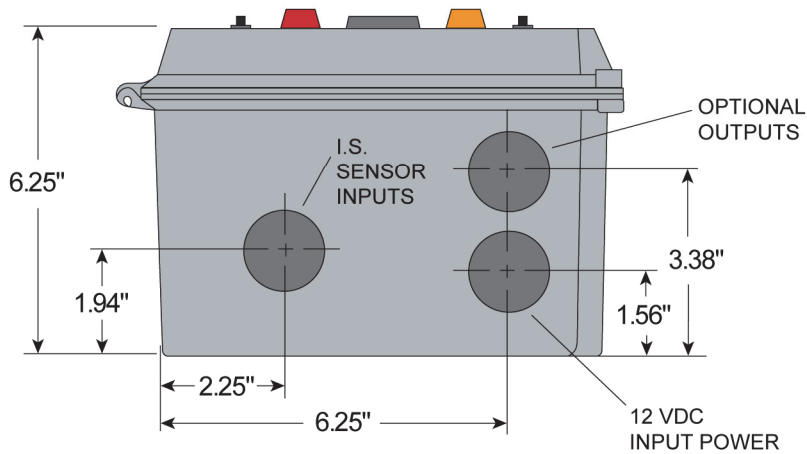
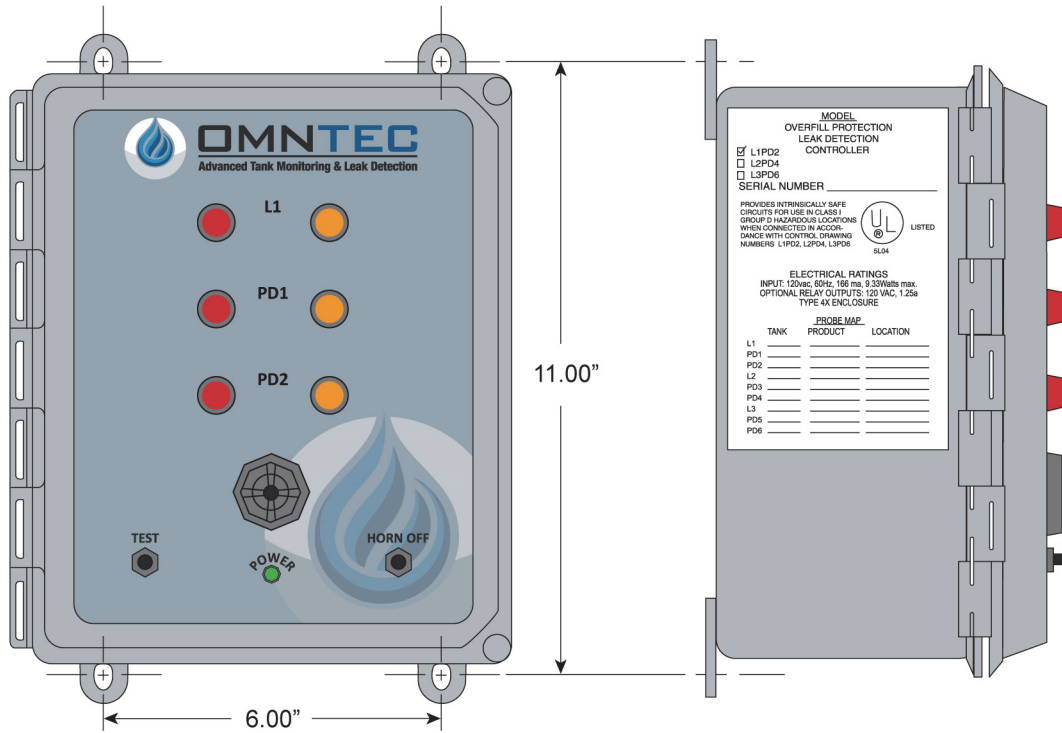

LPD-SERIES INSTALLATION INSTRUCTIONS

READ ALL INSTRUCTIONS PRIOR TO SYSTEM INSTALLATION. ALL WIRING IS TO BE DONE IN ACCORDANCE WITH ALL NATIONAL AND LOCAL ELECTRICAL CODES. POWER IS TO BE OFF DURING ANY WIRING. WIRE AND TEST ENTIRE SYSTEM BEFORE UTILIZING SK-4 CONNECTOR SEALING KITS. STANDARD EQUIPMENT IS COMPATIBLE WITH MOST PETROLEUM PRODUCTS. SOME CHEMICAL AND SOLVENTS REQUIRE SPECIFIC MATERIALS OF CONSTRUCTION. IF UNSURE OF COMPATIBLE CONTACT MANUFACTURER.

1. L-SERIES

1. L-SERIES

The L-1 (see pg. 13) is primarily used to detect a liquid level inside the tank. The sensor detects a single liquid level and is typically used for overfill protection at 90% tank capacity.

The L-1 sensor is installed into the tank via the 2" bushing which is an integral part of the L-1 sensor. This sensor screws directly into a 2" female threaded NPT (use a reducer bushing if necessary).

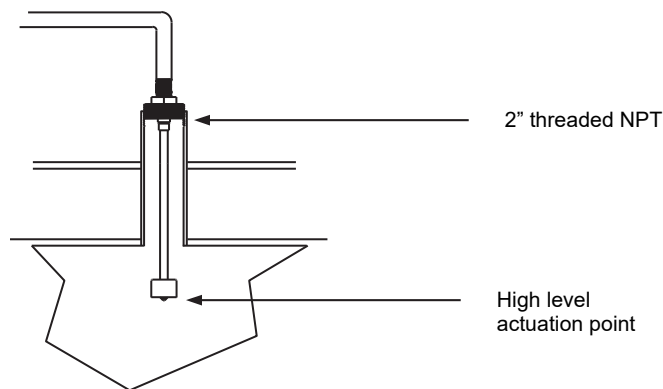

2. PDS SENSOR

The PDS sensor (see pg. 10) is designed to detect liquid in sumps or containment areas.

To install the PDS sensor as an above ground sump sensor mount a junction box between 2 and 3 feet above bottom of containment area. Attach sensor to junction box via conduit or cable clamp, leaving a ¼" clearance between the sensor end and the bottom of the containment area. For detailed wiring scheme refer to appropriate drawing (see pg. 9 and 18). Connect sensor cables to control unit cables in junction box using supplied SK-4 connector sealing kit.

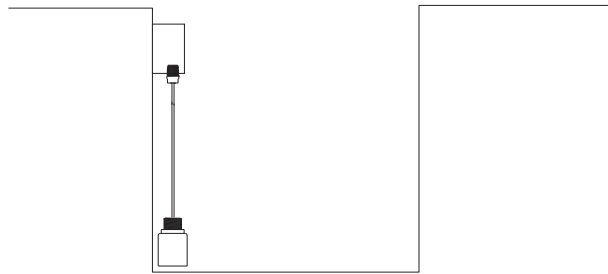

3. PDW-* SENSOR

PDW-* sensor (see pg. 11 and 12) is designed to detect liquid and differentiate water from hydrocarbons in the interstitial space of a double wall tank. The PDWF-* sensor is designed for fiberglass tanks and the PDWS sensor is designed for steel tanks.

1. PDWF SERIES

The PDWF-* sensor is installed through the interstitial port. If the tank is pitched, locate the interstitial sensor at lowest elevation of tank. Insert sensor into the interstitial port and push down around outside of inner tank. When PVC handle contacts the inner tank the sensor should be located at the bottom of interstitial space. Reduce the riser to 3/4" NPT and install the supplied oiltight fitting. The oiltight fitting must be installed to prevent liquids from entering the interstitial space. Run conduit from interstitial manhole to the central junction box, located in the manway. Install a second oiltight on the sensor cable and pull sensor cable through conduit. Connect oiltight to conduit and tighten. For detailed wiring scheme refer to appropriate control drawing (see pg. 9 and 18). Connect sensor wires in central junction box to control unit cable(s) and use SK-4 connector sealing kit.

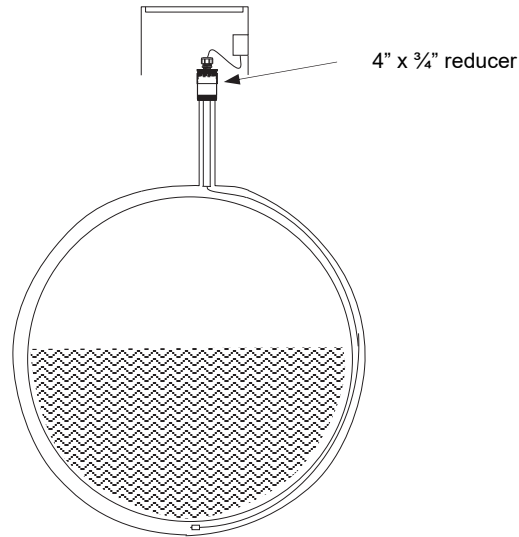

2. PDWS

To install the PDWS as a doublewall steel tank sensor remove the oiltight from the sensor cable. Feed the cable through the appropriate bushing required to adapt the interstitial port to 3/4" NPT (oiltight). Feed wires through oiltight, leaving it loose. Gently lower sensor down interstitial port until it rests on the bottom. Install oiltight into the bushing. Pull sensor up by the cable until it just comes off the bottom. Maintain this position and tighten the oiltight fitting. This is required to seal the interstitial port. All connections are made using the supplied SK-4 connector kit.

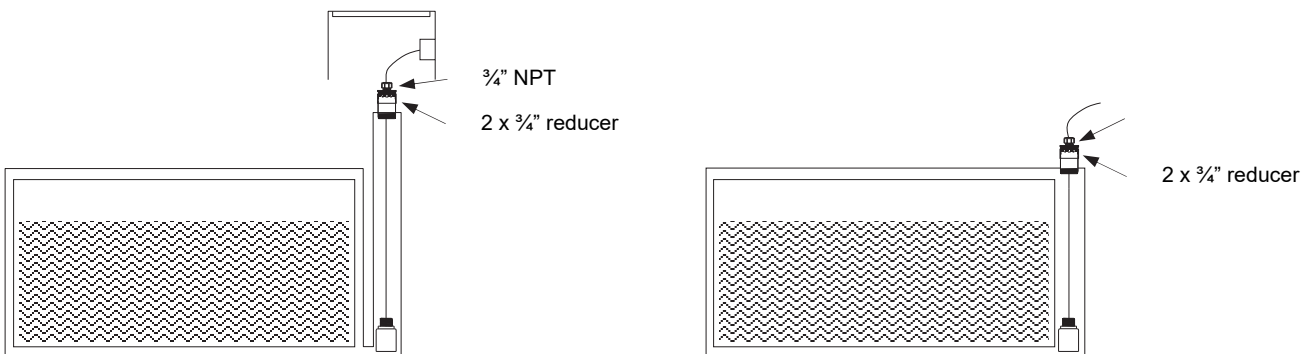

4. CONTROL UNIT

The control unit (see pg. 3) should be mounted in a manned area. Route sensor control cable through conduit from the junction box to the control unit. Sensor control cables enter the control unit through the output port only. The cables are wired as shown in the appropriate drawing (see pg. 9). The control unit accepts any possible combination of L-Series sensors.

1. INPUT POWER HOOKUP

Input power requirements are:
85-125 VAC
16 Watts max
47-440 Hz

Input power cable should be wired in accordance with all pertinent electrical codes. This cable should enter the control unit through the input power port only. The power is hooked up to the power supply and wired as per control drawing (see pg. 18).
NOTE: EARTH GROUND TERMINAL MUST BE CONNECTED.

2. REMOTE ANNUNCIATOR OPTION

Mount remote annunciator (see pg. 19) within audio / visual range of the filling operator. NOTE: the remote must be outside of the HAZARDOUS AREA. Pull appropriate low voltage wire from the remote to the control unit. See appropriate drawing for wiring details. Run wires through output port. Connect color coded nuts.

3. SK-4 CONNECTOR SEALING KIT

Make all splices using SK-4 connector kit (supplied).

L1PD2-12VDC CONTROLLER CONNECTION DIAGRAM

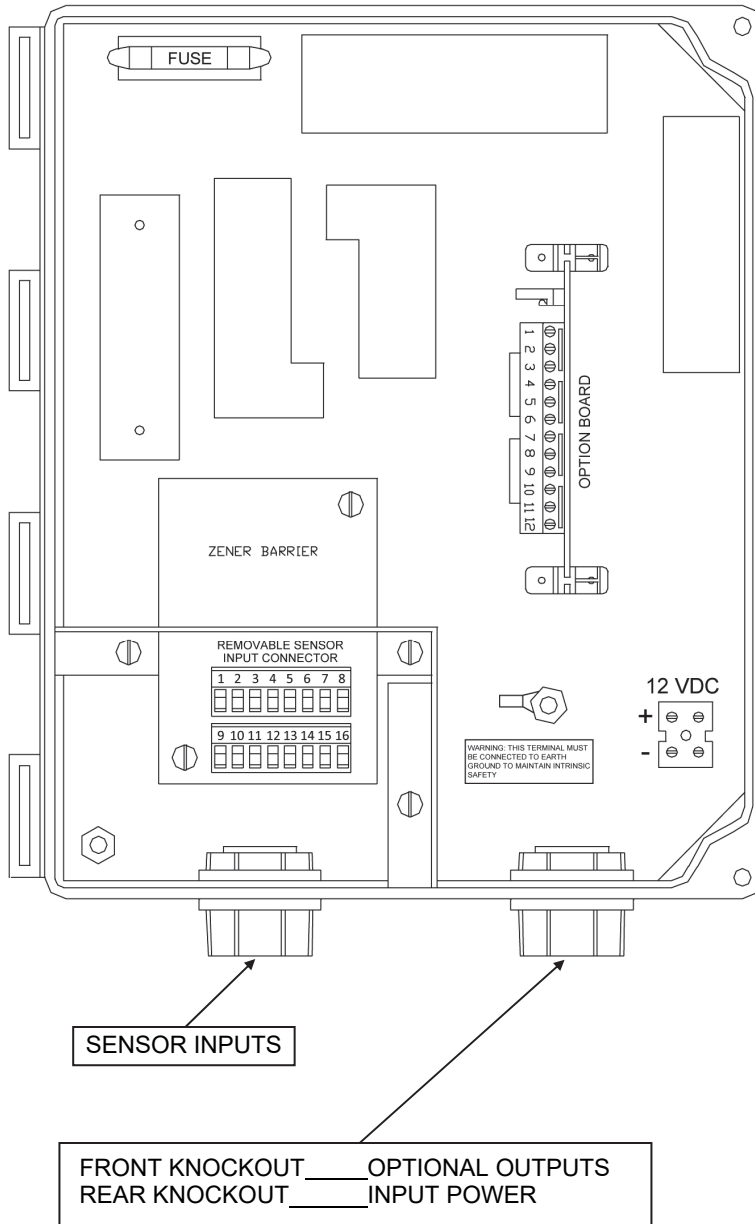

COLOR CODE

CABLES FROM SENSORS TO REMOVABLE SENSOR INPUT CONNECTORS

1	RED	L1 SENSOR #1 (L.E.D.)
2	WHITE	L1 SENSOR #1 (RETURN 1)
3	RED	PD1 SENSOR #2 (L.E.D.)
4	WHITE	PD1 SENSOR #2 (RETURN 1)
5	GREEN	PD1 SENSOR #2 (RETURN 2)
6	RED	PD2 SENSOR #3 (L.E.D.)
7	WHITE	PD2 SENSOR #3 (RETURN 1)
8	GREEN	PD2 SENSOR #3 (RETURN 2)
9	BLACK	FROM SENSOR #1, #2 & #3
10	SHIELD DRAIN	FROM SENSOR #1, #2 & #3
11	GREEN	L1 SENSOR #1 (RETURN 2)*
12	UNUSED	
13	UNUSED	
14	UNUSED	
15	UNUSED	
16	UNUSED	

*Used only for low level option

WIRES TO OPTION BOARD

WIRES FROM REMOTE

1	GREEN	- HORN
2	RED	+ HORN
3	BLACK	GROUND
4	WHITE	L1
5	ORANGE	PD1
6	BLUE	PD2

WIRES FROM RELAY OUTPUTS

7	COMMON	PD2 (LEAK)
8	NORMALLY OPEN	PD2 (LEAK)
9	COMMON	PD1 (LEAK)
10	NORMALLY OPEN	PD1 (LEAK)
11	COMMON	L1 (LEAK)
12	NORMALLY OPEN	L1 (LEAK)

12 VDC

WIRES TO POWERSUPPLY

+	12 VDC
-	GROUND

NOTE: To maintain proper shielding, BLACK sensor wires and SHIELD DRAINS should **not** be connected together at sensors.

PDS SENSOR

PRODUCT DISTINGUISHING OPTIC SENSOR

PRINCIPLES OF OPERATION

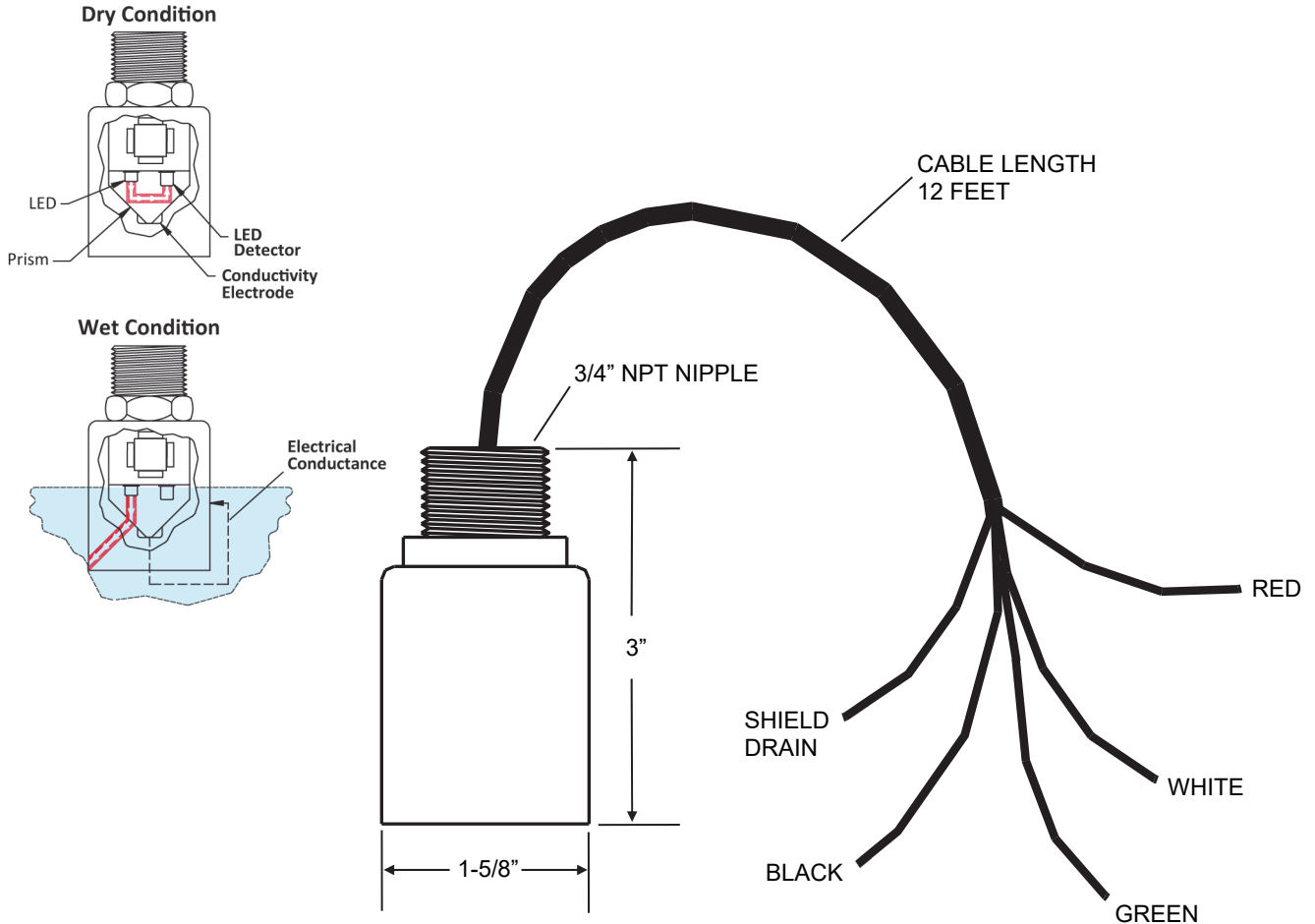

PDS SPECIFICATIONS

U.L. LISTED 5L04

Intrinsically safe Class I, Group D Hazardous Locations when connected in accordance with control drawing nos. L1PD2, L2PD4, L3PD6

OPERATING TEMPERATURE

-40 to +140 F

POWER

2 VDC @ 13 mA

WEIGHT

1/2 pound

PRINCIPLES OF OPERATION

Liquids (ex: fuel, water) - Photo optic
 Dry Condition - Normally closed light beam
 Alarm Condition - Opens (refracts) normally closed light beam
 Water Detection - Conductance

SENSOR CABLE

Shielded 22 AWG UL-E118830 CM
 Maximum length 2000 feet

RESPONSE TIME

Immediate

PDWF SENSOR

PRODUCT DISTINGUISHING FIBERGLASS TANK DRY INTERSTITIAL SENSOR

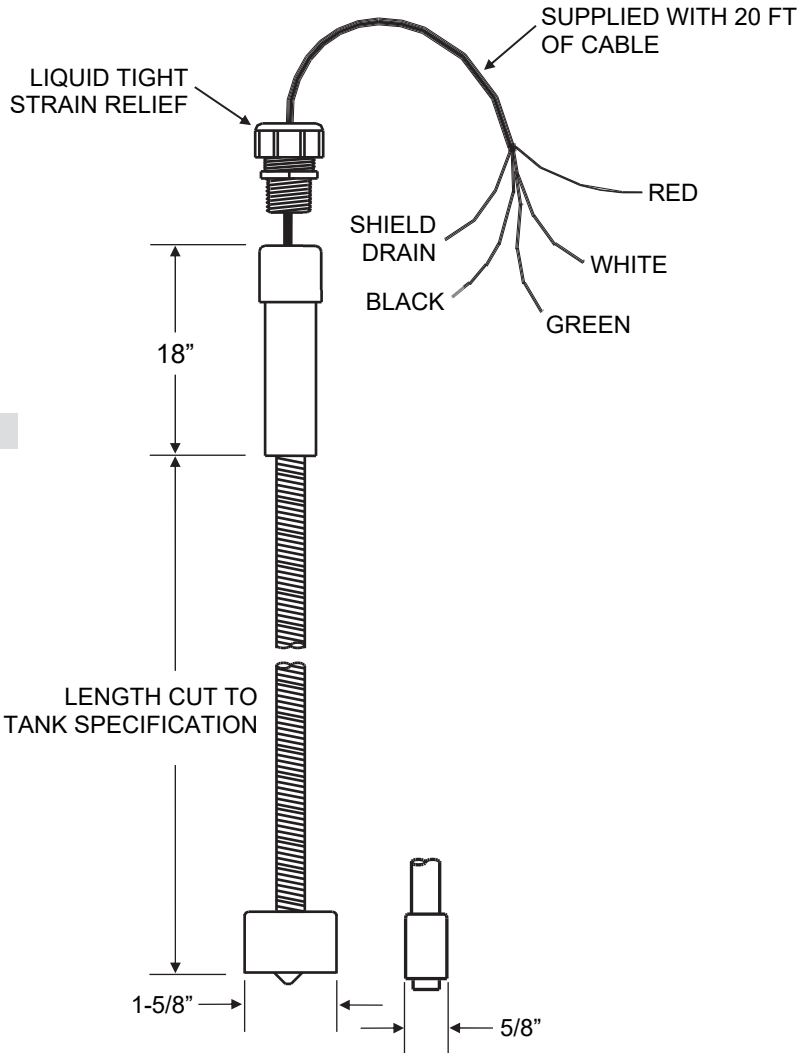

PRINCIPLES OF OPERATION

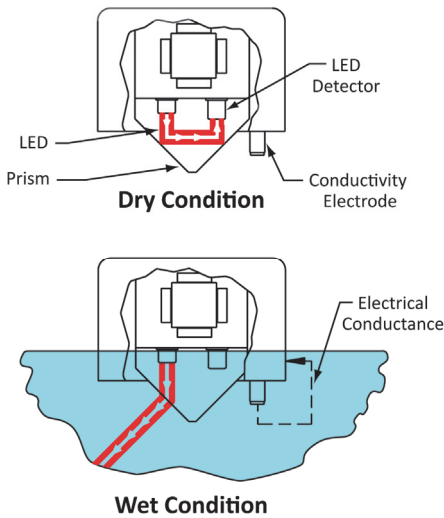

PDWF SPECIFICATIONS

U.L. LISTED 5L04

Intrinsically safe Class I, Group D Hazardous Locations when connected in accordance with control drawing nos. L1PD2, L2PD4, L3PD6

OPERATING TEMPERATURE

-40 to +140 F

POWER

2 VDC @ 13 mA

WEIGHT

1/2 pounds

PRINCIPLES OF OPERATION

Liquids (ex: fuel, water) - Photo optic
 Dry Condition - Normally closed light beam
 Alarm Condition - Opens (refracts) normally closed light beam
 Water Detection - Conductance

SENSOR CABLE

Shielded 22 AWG UL-E118830 CM
 Maximum length 2000 feet

RESPONSE TIME

Immediate

PDWS SENSOR

PRODUCT DISTINGUISHING STEEL TANK DRY INTERSTITIAL SENSOR

PRINCIPLES OF OPERATION

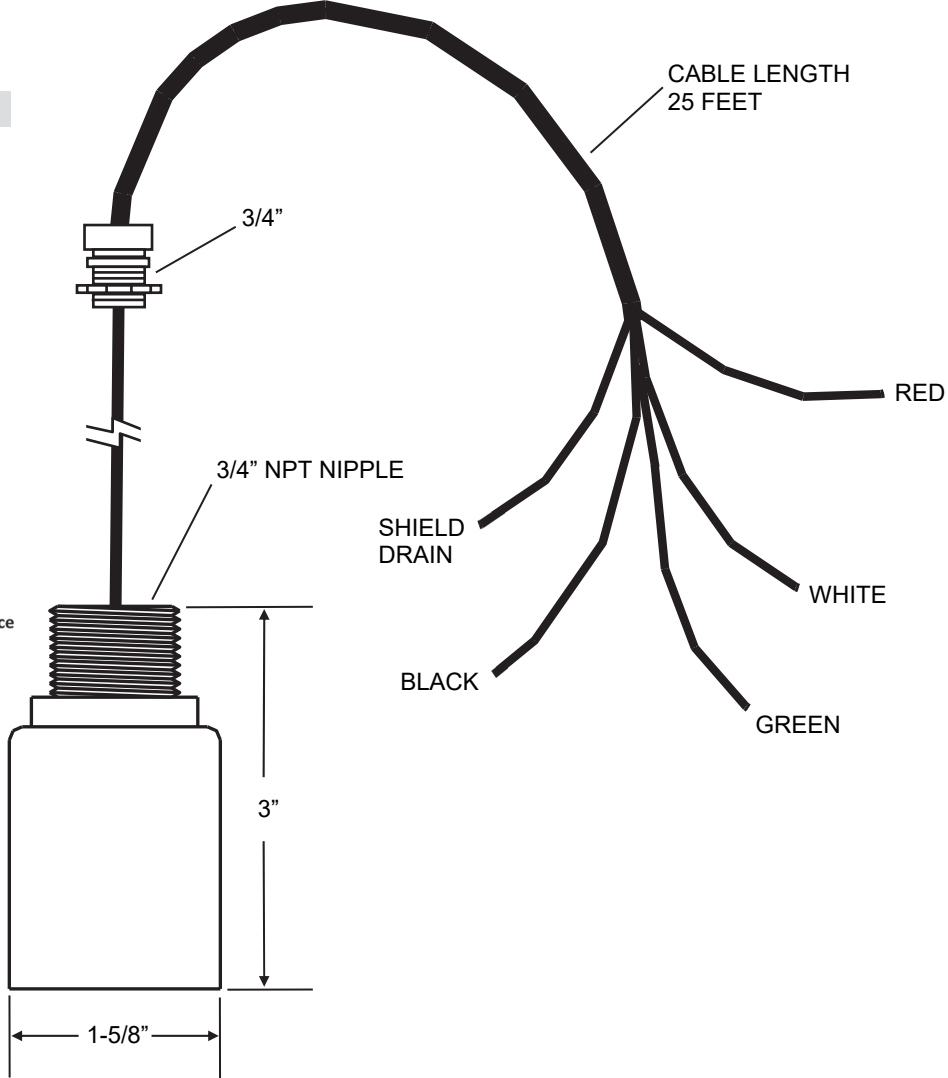
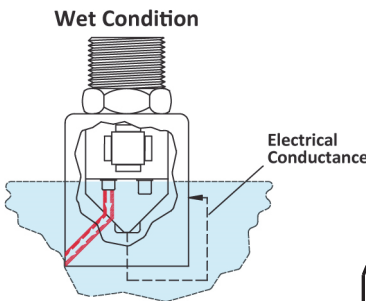
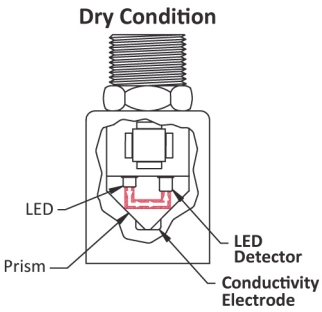

PDWS SPECIFICATIONS

U.L. LISTED 5L04

Intrinsically safe Class I, Group D Hazardous Locations when connected in accordance with control drawing nos. L1PD2, L2PD4, L3PD6

OPERATING TEMPERATURE

-40 to +140 F

POWER

2 VDC @ 13 mA

WEIGHT

1/2 pound

PRINCIPLES OF OPERATION

Liquids (ex: fuel, water) - Photo optic
 Dry Condition - Normally closed light beam
 Alarm Condition - Opens (refracts) normally closed light beam
 Water Detection - Conductance

SENSOR CABLE

Shielded 22 AWG UL-E118830 CM
 Maximum length 2000 feet

RESPONSE TIME

Immediate

L-1 SENSOR

LIQUID LEVEL OPTIC SENSOR

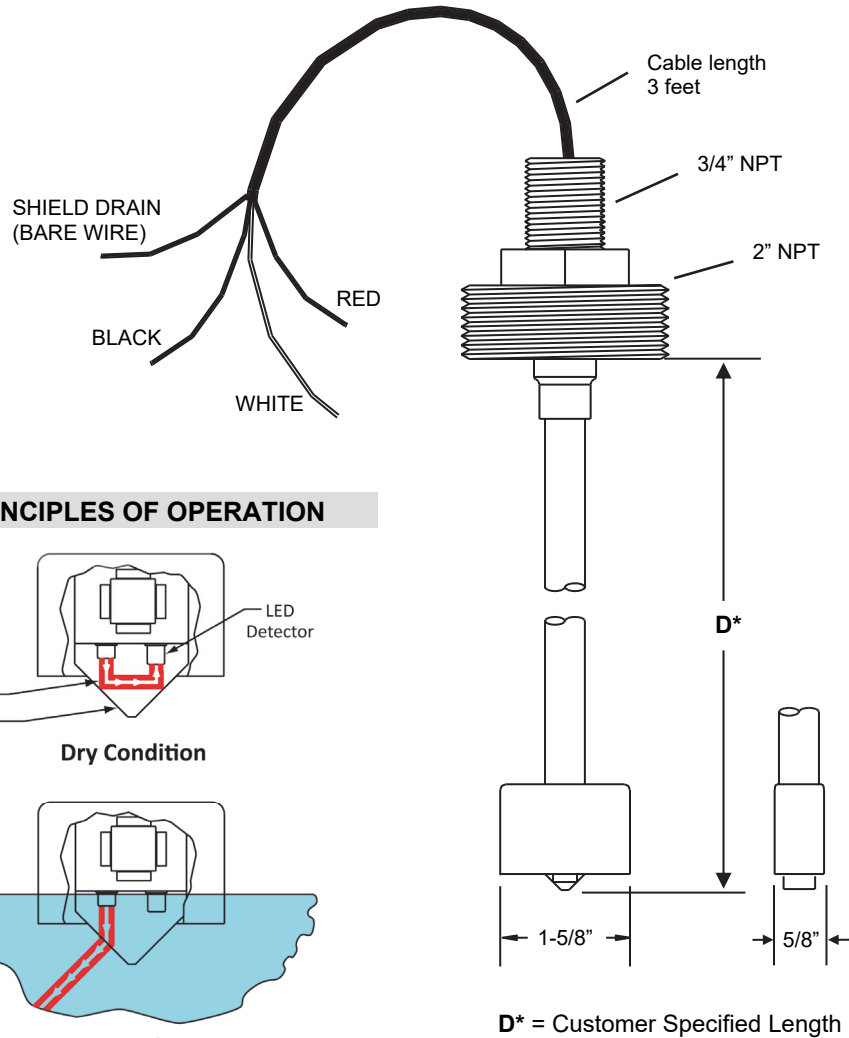

PRINCIPLES OF OPERATION

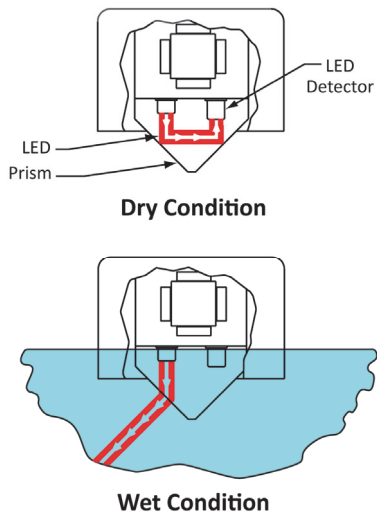

L-1 SPECIFICATIONS

U.L. LISTED 5L04

Intrinsically safe Class I, Group D Hazardous Locations when connected in accordance with Control Drawing nos. L1, L2, L3, L4, L6, L9

OPERATING TEMPERATURE

-40 TO +140 F

POWER

2 VDC @ 13 mA

WEIGHT

2 pounds

PRINCIPLES OF OPERATION

Liquids (ex: fuel, water) - Photo optic
 Dry Condition - Normally closed light beam
 Alarm Condition - Opens (refracts) normally closed light beam

SENSOR CABLE

Shielded 22 AWG UL-E118830 CM
 Maximum length 2000 feet

RESPONSE TIME

Immediate

L-2 SENSOR

DUAL LEVEL LIQUID OPTIC SENSOR FOR HIGH AND CAUTION LEVEL

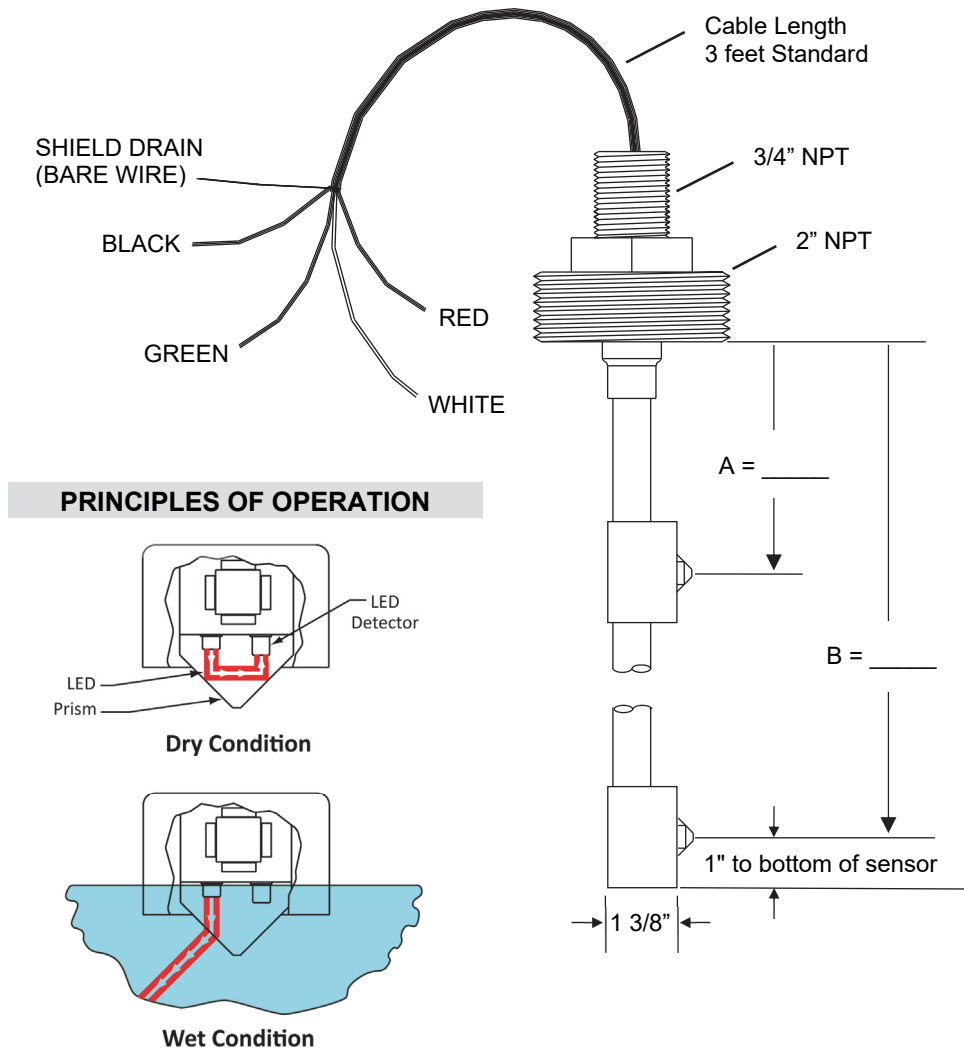

L-2 SPECIFICATIONS

U.L. LISTED 5L04

Intrinsically safe Class I, Group D Hazardous Locations when connected in accordance with Control Drawing nos. L1, L2, L3, L4, L6, L9

PRINCIPLES OF OPERATION

Liquids (ex: fuel, water) - Photo optic
 Dry Condition - Normally closed light beam
 Alarm Condition - Opens (refracts) normally closed light beam

OPERATING TEMPERATURE

-40 TO +140 F

SENSOR CABLE

Shielded 22 AWG UL-E118830 CM
 Maximum length 2000 feet

POWER

2 VDC @ 13 mA

RESPONSE TIME

Immediate

WEIGHT

2 pounds

L-R-1 SENSOR RESERVOIR SENSOR

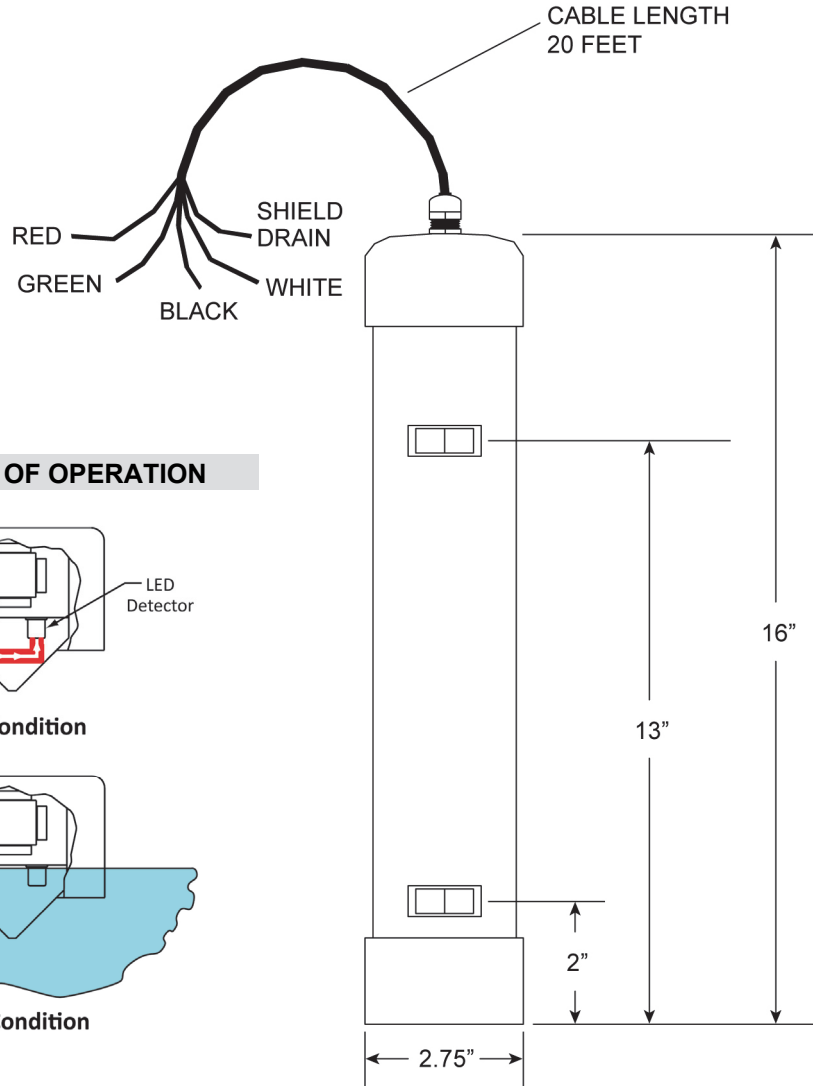

PRINCIPLES OF OPERATION

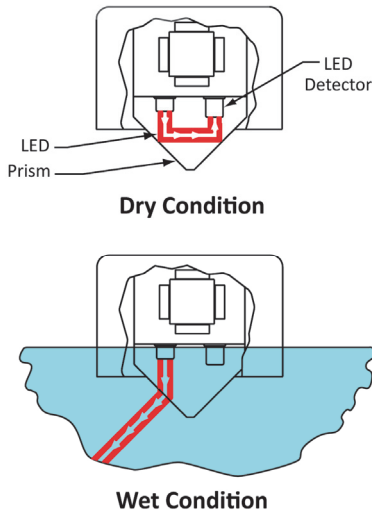

L-R-1 SPECIFICATIONS

SOLID STATE (NO MOVING PARTS)

OPERATING TEMPERATURE

-40 TO +140 F

POWER

2 VDC @ 13 mA

WEIGHT

2 pounds

RESPONSE TIME

Immediate

PRINCIPLES OF OPERATION

LIQUIDS (ex: fuel, water) - Photo optic

DRY CONDITION -

High level: Normally closed light beam

Low Level: Normally open light beam

ALARM CONDITION -

Hi level: Opens (refracts) normally closed light beam

Low level: Closes normally open light beam

SENSOR CABLE

Shielded 22 AWG UL-E118830 CM

Maximum length 2000 feet

L-R-1 SENSOR

TYPICAL RESERVOIR SENSOR INSTALLATION

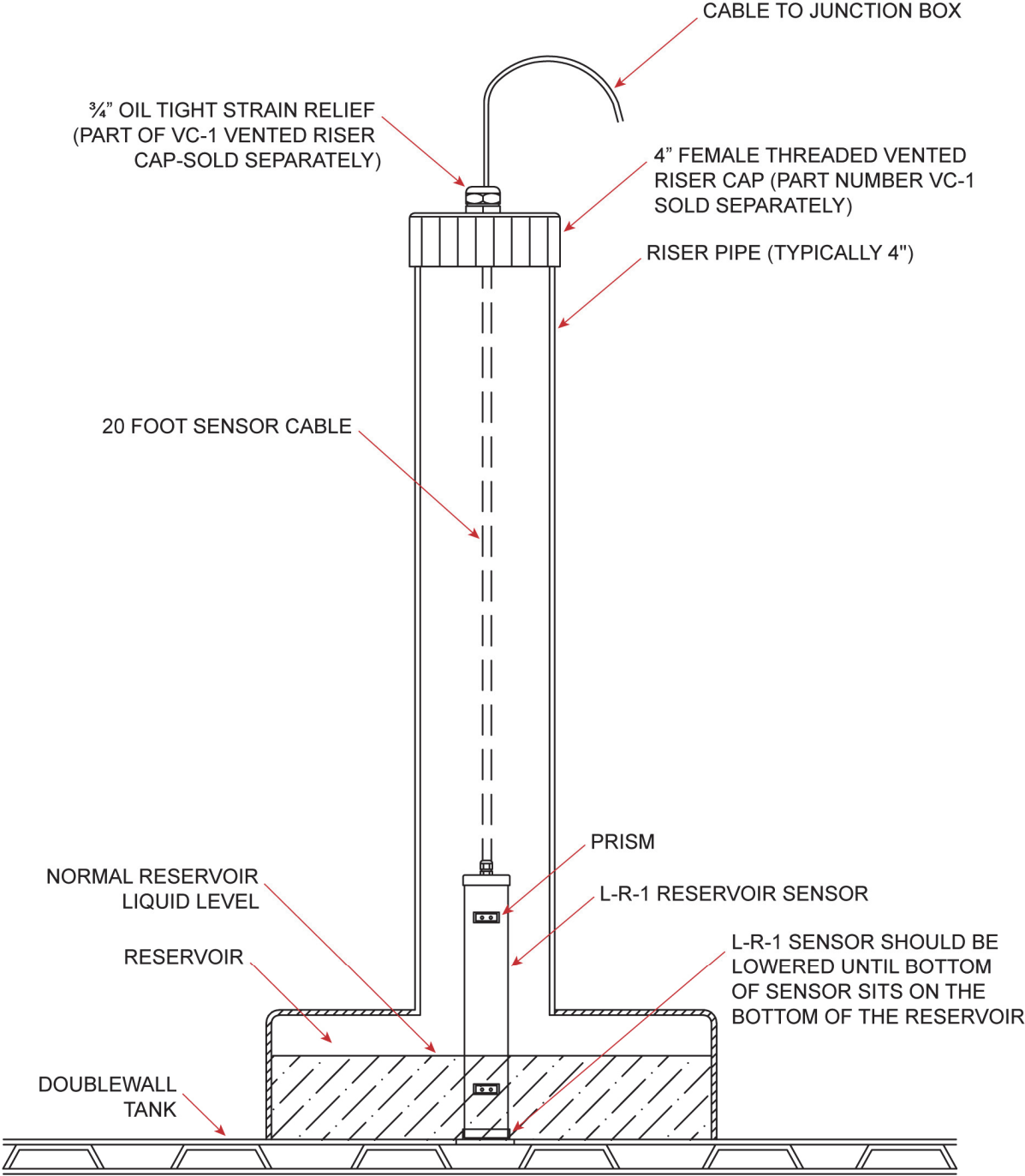

LPD SERIES SYSTEM OPERATION AND TEST INSTRUCTIONS

1. On the front panel the Green “SYSTEM DETECTING” light should be on indicating that system is up and running
2. If sensors are not in alarm, all Red and Amber lights should be off (see figure 1)
 - a) Optical sensors are solid state and use a normally closed light loop in a prism for sensing. When liquid is present at sensor, the normally closed loop opens, thus sending an alarm signal back to the alarm panel. The panel responds by turning on the appropriate light and sounding an audible alarm (see figure 2). The audible alarm will signal for 30 seconds. The visual alarm will remain on until alarm condition is cleared.
 - b) PD-Series sensors contain a conductivity electrode that will send an alarm upon presence of water. In the unlikely event that the conductivity electrode does not detect water, the sensor will send a liquid alarm signal to the controller as described in 2(a).
 - c) Since OMNTEC employs electro-optic technologies and works with a normally closed beam of light. Any wire break, disconnection, or sensor malfunction will be immediately indicated at the control panel.
3. Sensors can be tested as follows:
 - a) Since sensors work with normally closed loop of light be sure sensor is not exposed to light source of any kind.
 - b) Hit the test button on alarm panel and observe panel lights (see figure 3).
 - c) If all lights illuminate and audible alarm sounds, system test is complete.
 - d) When test button is hit a signal is sent to sensor to turn its light off. What this does is put the sensor into an alarm condition simulating an actual alarm even by opening the normally closed light loop.
 - e) The sensor then responds as explained in part 2(a).
 - f) Pressing Horn OFF button will silence audible alarm.
 - g) The conductivity portion of the sensor can be tested by submerging the sensor in water.
4. System should be tested on at least a weekly basis
5. The physical location of all sensors should be checked for proper location, at a minimum, on an annual basis (ie. *high level, interstitial, sump, piping sump).
6. Every alarm, malfunction and test result should be recorded in a dated signed log

Note: If a reservoir or high/low sensor is being used follow same procedures as above to test its high level portion. To test low level sensor, it must either be lifted out of liquid, or liquid level must be lowered below sensor

**L-series sensor high level to be set at no greater than 95%. Pump shutdown available when using RLY series relays.*

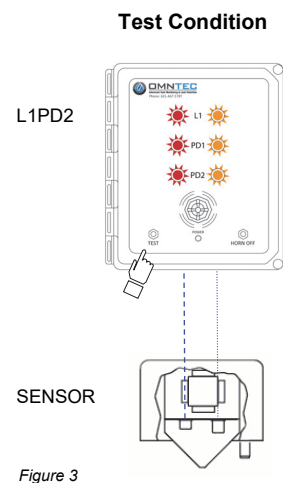
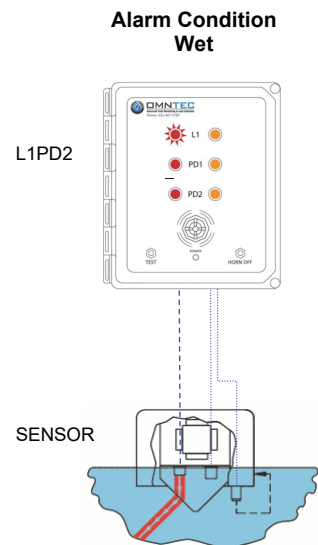
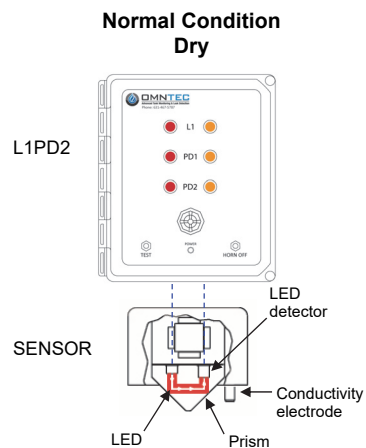

----- Normal signal
----- Alarm signal

L1PD2 CONTROL DRAWING

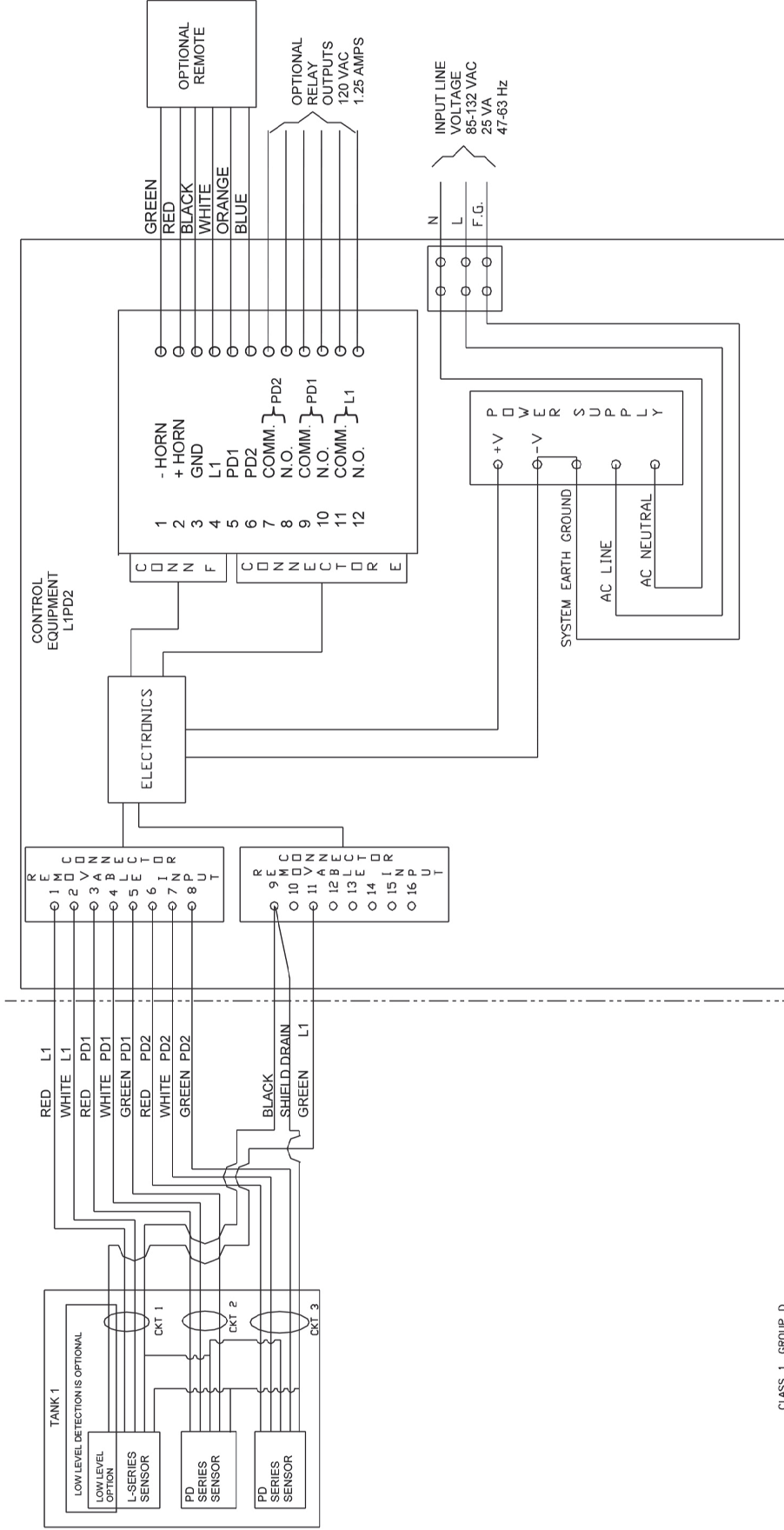

CLASS 1, GROUP D
HAZARDOUS AREA

NOTES ON PROBES

1. LOOP ALL SENSOR GROUNDS (BLACK WIRES) FOR EACH TANK.
2. LOOP ALL SENSOR SHIELD DRAINS (BARE WIRES) AT EACH TANK.
3. LOW LEVEL DETECTION IS OPTIONAL. WHEN SPECIFIED, IT IS AN INTEGRAL PART OF THE HIGH LEVEL SENSOR. THE GREEN WIRE OF CIRCUIT 1 IS UTILIZED ONLY WHEN LOW LEVEL DETECTION IS PRESENT.
4. THE INTRINSICALLY SAFE FIELD WIRING SHALL BE INSTALLED IN ACCORDANCE WITH ARTICLE 504 IN THE NATIONAL ELECTRICAL CODE ANSI/NFPA 70.
5. ALL SENSORS ARE ELECTRONICALLY IDENTICAL AND MAY BE INTERCHANGED ALLOWING SYSTEM FLEXIBILITY.
6. SENSOR TO CONTROL UNIT CABLE WILL BE TWO PAIR OF #22 AWG WITH SHIELD AND DRAIN PVC JACKETED UL-118830 CM. CABLE LENGTH WILL BE LIMITED TO 2000 FEET MAXIMUM.

NON-HAZARDOUS AREA

NOTES ON CONTROL EQUIPMENT

1. ALL WIRING MUST MEET LOCAL AND NATIONAL ELECTRICAL CODES.
2. SYSTEM EARTH GROUND MUST BE CONNECTED TO TERMINAL F.G. TO INSURE INTRINSIC SAFETY AND MUST BE LESS THAN 1 Ω WITH RESPECT TO EARTH GROUND.
3. OPTIONAL REMOTE REQUIRES #22 AWG LOW VOLTAGE COMMUNICATION CABLE MINIMUM.

Control Drawing No. L1PD2

RA-SERIES REMOTE HIGH-LEVEL ALARM

RA-1



RA-2



RA-3



RA-4



INTERNAL WIRING COLOR CODE

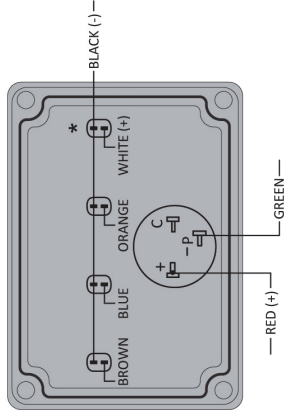
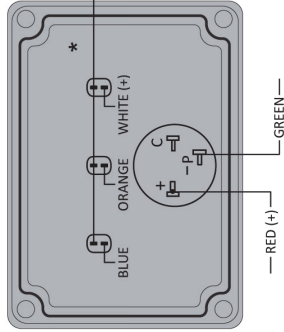
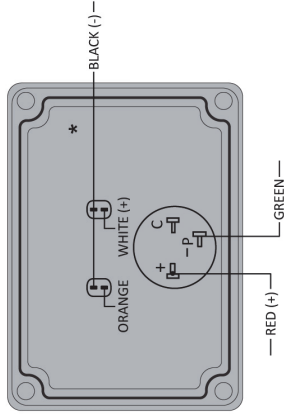
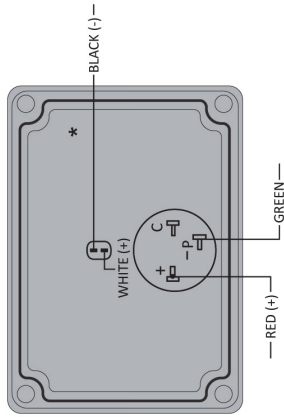

***Warning Label Placed Here** **WARNING: LOW VOLTAGE INPUTS ONLY**

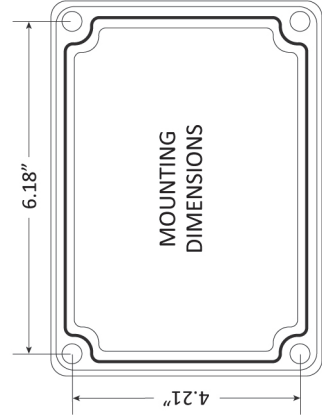
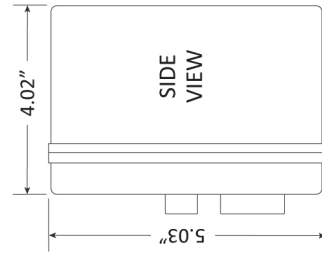

SPECIFICATIONS

Audible Alarm	95 dB pulsing horn
Red Light	Liquid-high-level alarm
Response Time	Immediate
Power Input	12VDC @200mA maximum from controller
Wire	22 AWG minimum
Weight	1 lb.

Note: It is recommended that knockouts be placed in the bottom of enclosure.

WARRANTY

The seller OMNTEC Mfg., Inc. warrants to buyer defects when properly installed, and maintained by user. The seller's sole obligation is to repair or replace parts found to be defective, or non-conforming for one year and only after evaluation by factory. The liability of the seller shall not exceed the price paid for the components found to be defective. The above warranty is exclusive of all other warranties whether implied or expressed. Seller assumes no obligation for special or, indirect damages incurred by user.

All standard tank gauging systems are free of defects when properly installed and maintained by user. Warranty on tank gauging systems will only be effective after proper documentation has been submitted by the buyer to OMNTEC Mfg., Inc. The seller's sole obligation is to repair or replace parts found to be defective, or non-conforming for one year and only after evaluation by factory. Technical support must be contacted for a Return Material Authorization (RMA #) prior to sending any potentially defective parts. The liability of the seller shall not exceed the price paid for the components found to be defective. The above warranty is exclusive of all other warranties whether implied or expressed. Seller assumes no obligation for special or indirect damages incurred by user.

All standard replacement parts, "add-ons", or spare parts are free of defects when properly installed and maintained by user. The seller's sole obligation is to repair or replace parts found to be defective or non-conforming for 90 days and only after evaluation by factory. The liability of the seller shall not exceed the price paid for the components found to be defective. The above warranty is exclusive of all other warranties whether implied or expressed. Seller assumes no obligation for special or indirect damages incurred by user.

Equipment not covered by this warranty includes but is not limited to: custom equipment and control systems.