

**SPECIFICATIONS**

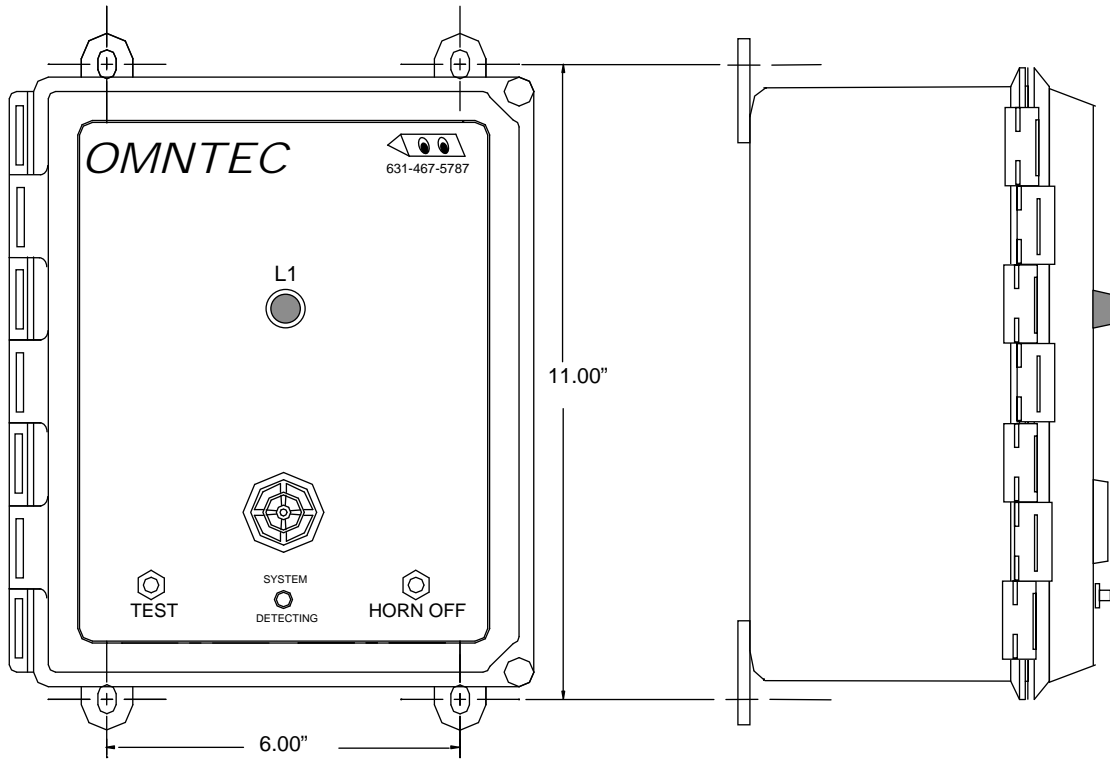

**POWER INPUT**

85-125 VAC, 47-440 Hz  
16 Watts maximum

**POWER TO CONTACTS**

2 VDC @ 13 ma

**WEIGHT      DIMENSIONS**

6 LBS.      (W) 9" x (H) 10.5"

**SENSOR CABLE**

Shielded 22 AWG UL-E118830 CM  
Maximum length 2000 feet

**ENCLOSURE      OPERATING TEMPERATURE**

NEMA 4X      -40° to 140° F

**AUDIO/VISUAL REMOTE**

**AUDIBLE ALARM** - 95 dB pulsing horn with 30 second timeout

**RED LIGHT** -Indicates open contact

**TEST BUTTON**- When pressed will test audible alarm and lights

**GREEN LIGHT**- indicates the power is on

**HORN OFF BUTTON** - Silences the audible alarm when pressed

**DRY CONTACT INPUT**

Normally open

**LABELS**

Provided with controller

Dimensions for mounting and knockouts

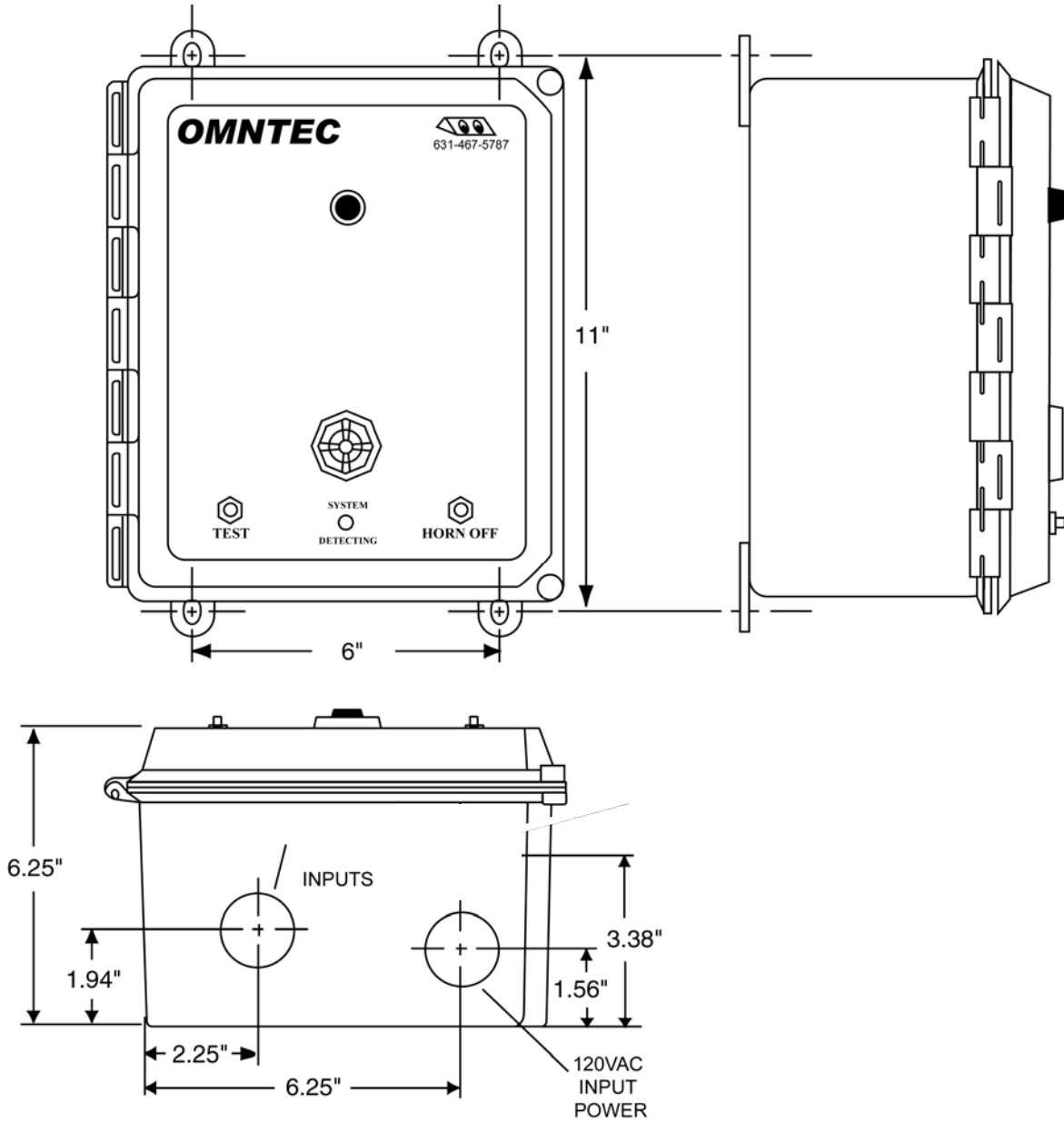

# RA-LU1 REMOTE CONNECTION DIAGRAM

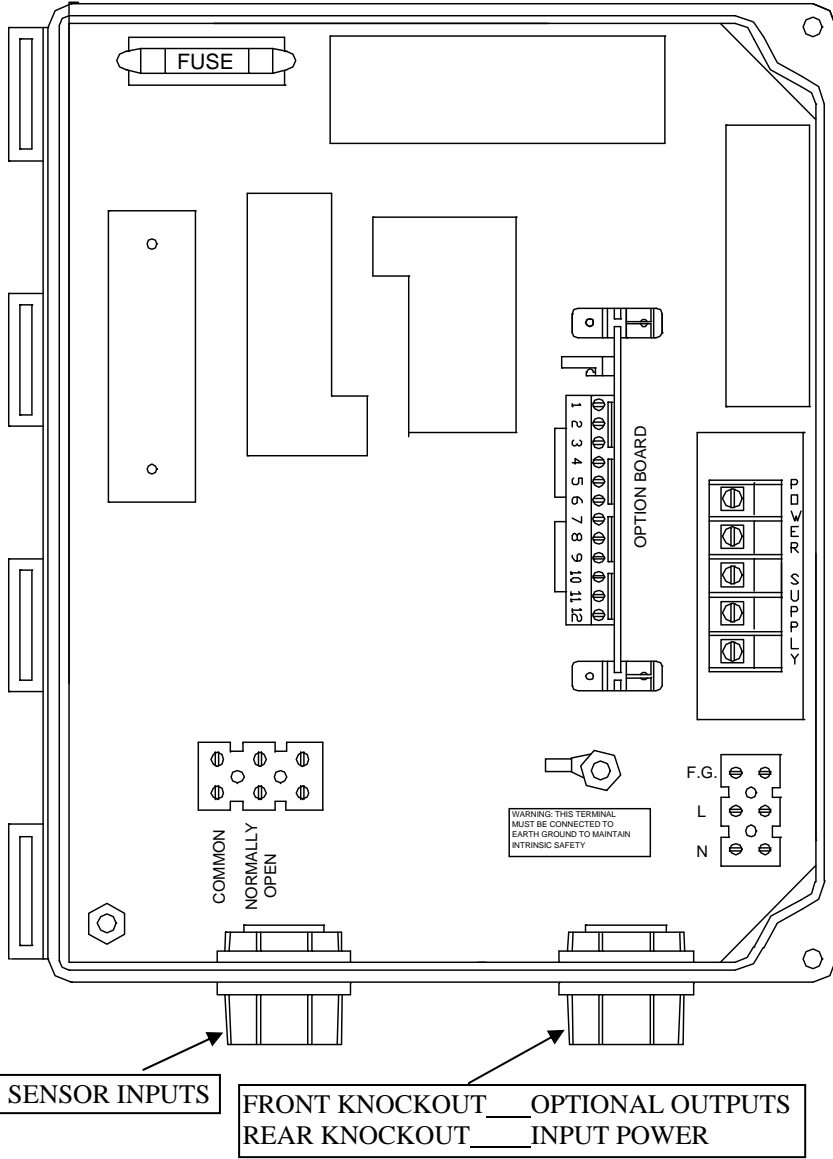

<b>120VAC</b>	
<b>WIRES TO POWER SUPPLY</b>	
F.G.	FIELD GROUND
L	LINE
N	NEUTRAL

**NOTE:** To maintain proper shielding, BLACK sensor wires and SHIELD DRAINS should **not** be connected together at sensors.

## Warranty

---

The seller OMNTEC Mfg., Inc. warrants to buyer defects when properly installed, and maintained by user. The sellers sole obligation is to repair or replace parts found to be defective, or non-conforming for one year and only after evaluation by factory. The liability of the seller shall not exceed the price paid for the components found to be defective. The above warranty is exclusive of all other warranties whether implied or expressed. Seller assumes no obligation for special or, indirect damages incurred by user.

All standard tank gauging systems are free of defects when properly installed and maintained by user. Warranty on tank gauging systems will only be effective after proper documentation has been submitted by the buyer to OMNTEC Mfg., Inc. The sellers sole obligation is to repair or replace parts found to be defective, or non-conforming for one year and only after evaluation by factory. The liability of the seller shall not exceed the price paid for the components found to be defective. The above warranty is exclusive of all other warranties whether implied or expressed. Seller assumes no obligation for special or indirect damages incurred by user.

All standard replacement parts, "add-ons", or spare parts are free of defects when properly installed and maintained by user. The sellers sole obligation is to repair or replace parts found to be defective or non-conforming for 90 days and only after evaluation by factory. The liability of the seller shall not exceed the price paid for the components found to be defective. The above warranty is exclusive of all other warranties whether implied or expressed. Seller assumes no obligation for special or indirect damages incurred by user.

Equipment not covered by this warranty includes, but is not limited to: custom equipment, pressure transducers, and control systems.