

OMNTEC MTG*-Probe Installation for Corrosive Chemical Applications

Note: Before Probe Installation

1. Take a level reading at the probe riser with a gauge stick and record the information for system set-up.
2. Record wire speed and probe length on top of probe for system set-up.

CAUTION

Floats must not be allowed to drop down shaft during installation. May result in damage to probe. Floats must slowly be lowered to the base of the shaft before insertion.

CAUTION

Probe must be lowered slowly until the probe foot touches the tank bottom. Sudden impact may result in damage to probe or tank. Lift probe a minimum of 1" off bottom of tank to allow for tank deflection.

CAUTION

EXTENSION CABLE from MTG probe to OEL8000II must be **OMNTEC EC-2** or BELDEN #8761

1 INSERT PROBE INTO RISER

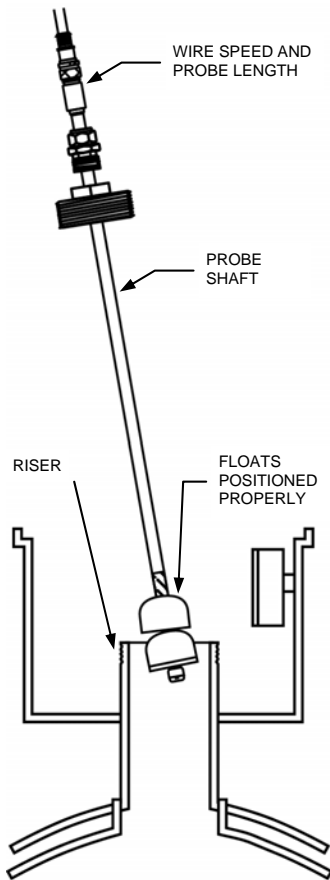

2 LOWER PROBE INTO TANK

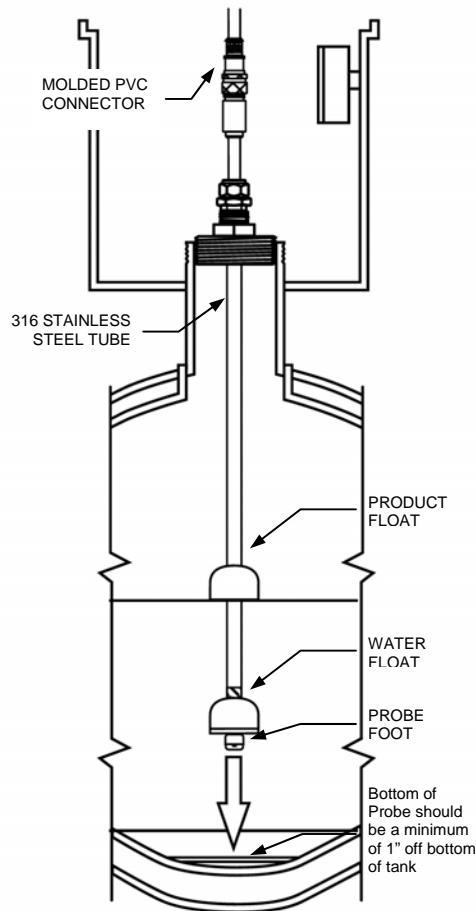

3 CHECK MINIMUM CLEARANCE

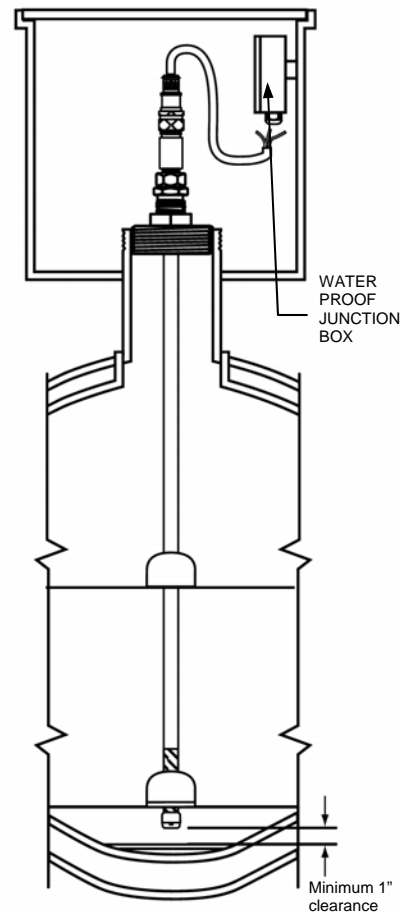

4 TIGHTEN FITTINGS AND WIRE INTO JUNCTION BOX

