

# FLANGED BALL CHECK VALVE

## TECHNICAL PASSPORT

### BALL CHECK VALVE - DUCTILE IRON BODY FLANGE CONNECTION PN10

**CBL 4240**

#### APPLICATION

The TECOFI ball check valve is suitable for wastewater transfer applications and for heavy or viscous fluids.



**General use:** discharge of wastewater, purification, sanitation, pumping

#### GENERAL CHARACTERISTICS

**Range:** from DN40 to DN400.

- Design according to EN 16767.
- Resilient seated non return check valve.
- Mounting direction is indicated by an arrow on the body.
- Self-cleaning ball that moves freely in the body,
- Low pressure drop.
- Complete erasure of the ball allowing full passage.
- Mounting in horizontal or vertical ascending position.
- Lifting ring on the bonnet for easy handling.
- Easy maintenance thanks to the easy disassembly of the bonnet.
- Plug for unclogging the ball under the body.



#### STANDARDS

<b>Design</b>	Meets the requirements of European Directive 2014/68/UE: «Equipment under pressure» modulate H.
<b>Face to face</b>	Face to face dimension according to NF EN 558-1 serie 48, DIN 3202/1 serie F6.
<b>Connection</b>	Flanged connection EN 1092-2 ISO PN10 in standard, PN 16 by request.
<b>Tests</b>	Hydraulic tests according to EN12266-1, DIN 3230, BS 6755 and ISO 5208: - Body : 15 bar - Seat : 11 bar

#### PRODUCT APPROVALS



#### Tecofi France

83 rue Marcel Mérieux - 69960 Corbas  
Tél. +33 (0)4 72 79 05 79 - Fax. +33 (0)4 78 90 19 19  
E-mail : sales@tecofi.fr - [www.tecofi.fr](http://www.tecofi.fr)



# FLANGED BALL CHECK VALVE

## TECHNICAL PASSPORT

**CBL 4240**

### CONSTRUCTION

Component	Coating
Body (1)	Epoxy powder RAL 5015 thickness 250µm
Bonnet (2)	Epoxy powder RAL 5015 thickness 250µm

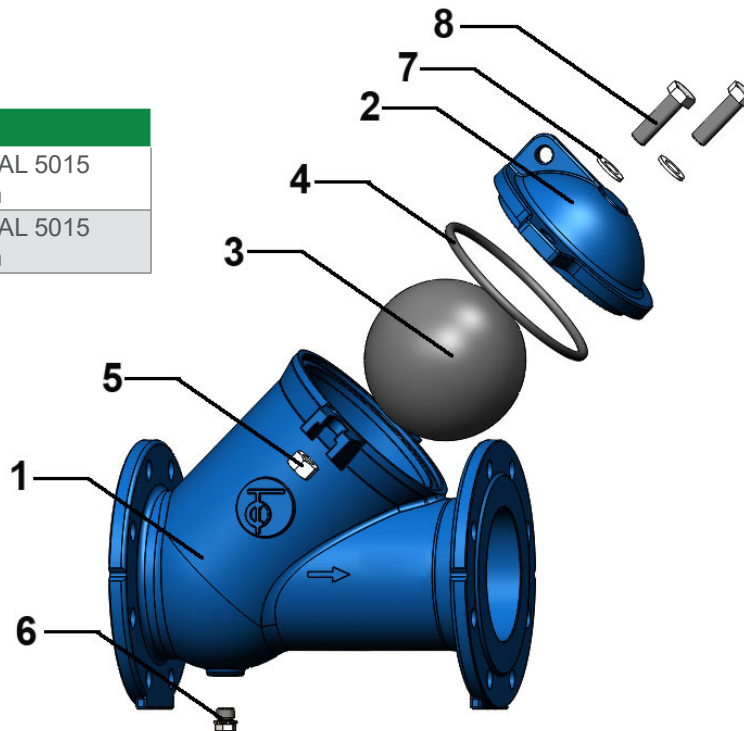

Pos.	Q-ty	Description	Material	Equivalences		
				DIN	ASTM	BS
1	1	Body	Ductile iron EN-GJS-500-7	GGG 50	A536 70-50-05	1563 EN-JS1050
2	1	Bonnet	Ductile iron EN-GJS-500-7	GGG 50	A536 70-50-05	1563 EN-JS1050
3	1	Ball	DN 40-50 : NBR DN 65-80 : Aluminium + NBR DN 100-400 : Cast iron + NBR			
4	1	Gasket	NBR			
5	n*	Nut	Stainless steel A2-70			
6	2	Plug	Carbon steel			
7	n*	Washer	Stainless steel A2-70			
8	n*	Screw	Stainless steel A2-70			
9	1	Nameplate				

\* n= 2 (DN40-150) / 4 (DN200-350) / 6 (DN400)

### Tecofi France

83 rue Marcel Mérieux - 69960 Corbas  
Tél. +33 (0)4 72 79 05 79 - Fax. +33 (0)4 78 90 19 19  
E-mail : sales@tecofi.fr - [www.tecofi.fr](http://www.tecofi.fr)



## FLANGED BALL CHECK VALVE

### TECHNICAL PASSPORT

**CBL 4240**

#### DIMENSIONS

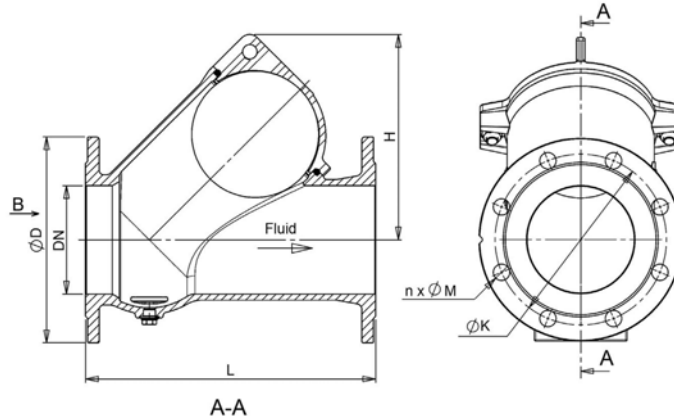

DN		L	H	Ø D	Ø K	n	Ø M	Cracking pressure (mbar)	Weight (kg)
mm	inch								
40	1 1/2	180	100	150	110	4	19	6.9	5.63
50	2"	200	113	165	125	4	19	12.6	7.56
65	2 1/2	240	135	185	145	4	19	20.5	10.11
80	3"	260	165	200	160	8	19	12.0	12.73
100	4"	300	203	220	180	8	19	16.0	18.47
125	5"	350	247	250	210	8	19	41.6	30.25
150	6"	400	284	285	240	8	23	25.7	38.50
200	8"	500	380	340	295	8	23	26.7	76.00
250	10"	600	464	400	350	12	23	32.5	125.3
300	12"	700	556	455	400	12	23	35.7	177
350	14"	800	651	505	460	16	23	54.2	276.5
400	16"	900	767	565	515	16	28	64.0	423

#### WORKING CONDITIONS

Maximum working pressure : 10 bar.  
Maximum working temperature : -10°C / +80°C.

⚠ Please consult us in the case of using under low load.

⚠ During the mounting it is recommended to maintain a distance of 3 to 5 times the minimal diameter upstream and downstream of an elbow or appliance. This makes it possible to stay out of areas of turbulence likely to increase the risk of wear.  
At the discharge of a pump it is advisable to carry out the assembly in accordance with the **FD CEN/TR 13932** standards

#### HEAD LOSS CHART

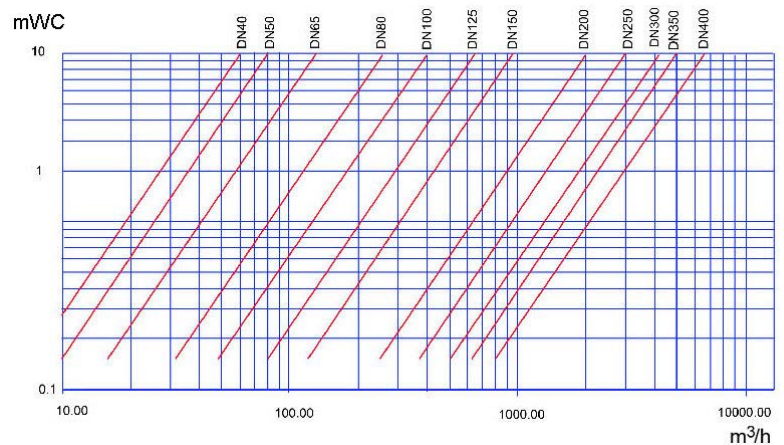

#### Tecofi France

83 rue Marcel Mérieux - 69960 Corbas  
Tél. +33 (0)4 72 79 05 79 - Fax. +33 (0)4 78 90 19 19  
E-mail : sales@tecofi.fr - [www.tecofi.fr](http://www.tecofi.fr)

