



Foundation 100 Series

Product Manual



Document ver.1 - March 2023

System Overview

Foundation 100 Series harnesses the power of the Raspberry Pi Compute Module 4, which provides the core functionality of the Raspberry Pi 4. Combined with our own industry-focused carrier board, and a custom-designed industrial chassis, Foundation 100 Series has been engineered for today's industrial and embedded applications.

Foundation 100 Series is running ISAAC Workspace which is accessible through your web browser.

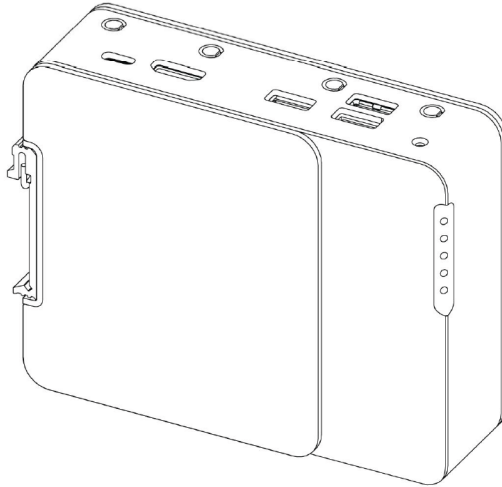

Accessories

- 1x Power supply kit (with Power Terminal Block)
- 1x Extra Power Terminal Block
- 1x Com Terminal Block
- 1x DIN Rail Mounting Kit (Edge)

Additional information can be found on our website at <https://www.isaacplatform.com>

System Dimensions	5.07" x 1.5" x 4" 129x 38 x 102 mm
Board Dimensions	4.47" x 3.85"
CPU (on solder side of board)	Raspberry Pi CM4 Headers
Memory	CM4-dependent, with 8GB
LAN Controller	1x Realtek RTL8153B (GbE) 1x from CM4 (GbE)
Expansion	1x M.2 2280 B-Key (USB 3.2 5Gb/s) 1x M.2 2280 B-Key (SATA III)
Back I/O	2x 1GbE LAN 1x 5-pin Serial (RS232/422/485) 3-pin Terminal Block with 12-24 V input
Front I/O	2x USB 3.2 10Gb/s 1x USB 2.0 1x HDMI 1x USB-C for CM4 Programming 1x Reset button
Onboard Headers & Connectors	1x Battery on a cable 1x Raspberry Pi Expansion Header (Female) 1x SPI TPM Header 1x CM4 Boot Mode Select 1x PoE PD Header 1x USB2 Modem Header
Voltage Input	12-24V or PoE PD
Power Input	3-pin Terminal Block or PoE PD
Operating Systems	Raspbian, Ubuntu 20.04
Special Features	RTC TPM header - support TPM01 Support for 4G LTE and GPS expansion cards
Thermal Standards (Subject to change through RFI and RFQ steps)	Board Operating Temperature: -20-60C Storage Temperature: -40-85C Operating Humidity: 10% - 95% (non-condensing)
Extra Chassis Features	4 Antenna holes M3x0.5 threaded mounting holes
Regulatory	SAFETY IEC/UL/EN 62368-1 EMC CISPR 32/35 Class A FCC Part 15 Class A IEC/EN 60601-1-2:2014 EMC Ready Radio Equipment Directive (2014/53/EU) [Only applicable for configurations with wireless transmitters] RoHS 3 Directive (2015/863/EU) WEEE Directive (2012/19/EU)

Exterior Features and Dimensions

Top I/O

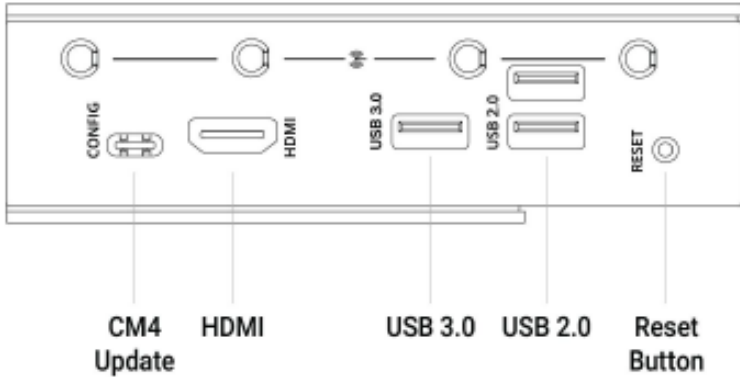

Bottom I/O

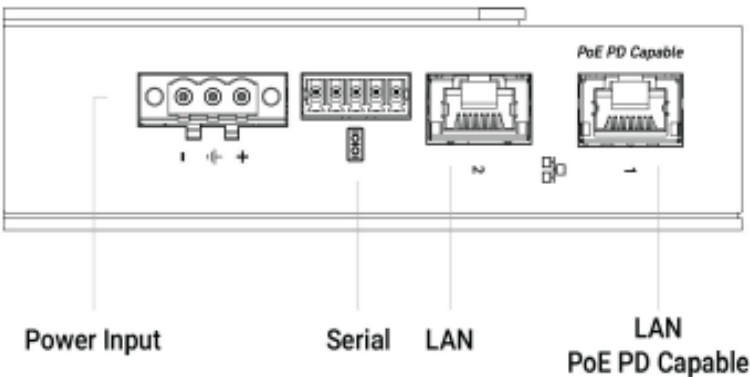

I/O Definitions

Dimensions

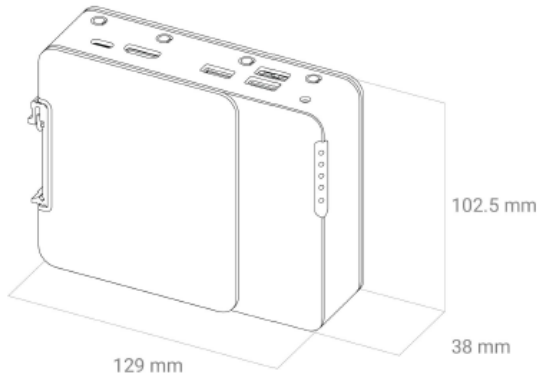

USB-C Config Port (CM4 Update by manufacturer only)

A USB-C port is provided to connect to the CM4 in USB 2.0 device mode, to update the bootloader firmware or modify the eMMC filesystem in USB MSD mode.

A USB 2.0 host used to connect Foundation 100 Series must provide a 5V output in order to enable the USB-C connection to the CM4. System power must also be provided separately via the main power input or PoE.

USB 3.x, alternate function modes, and power output are not supported on this connector.

HDMI

Foundation 100 Series uses the CM4's integrated HDMI to drive the external HDMI Port. Resolutions up to 4096x2304 @ 60Hz are supported. CEC (Consumer Electronics Control) functionality is also supported, depending on software configuration. This video output is not used by ISAAC Workspace.

USB 3.2 Gen1 5Gb/s

One USB 3.2 Gen1 (5Gb/s) port is provided for peripherals or boot media.

By default, this port is disabled during system boot to ensure that the CM4 boots from internal media. This behavior can be changed in software, or via the jumper header located in the center of the motherboard. See the headers section of this manual for more information.

USB 2.0

Two USB 2.0 ports are provided for peripheral usage. Together, they may deliver a maximum of 2A at 5V, depending on peripheral and device configuration.

Reset Button

The front reset button can be used to trigger a reset of the CM4. The reset button is a momentary contact button that is tool-accessible through the chassis.

3-Pin Terminal Block Power Connector

Mainboard power is applied to the Foundation 100 Series platform by way of a 3-pin terminal block connector (Mating part: Dinkle 2ESSM-03P or equivalent). The system is operational from 8V~24V. The maximum rated current of the connector is 15A per pin. Use a wire gauge that is rated for the operational current. See below for on-board connector pinout.

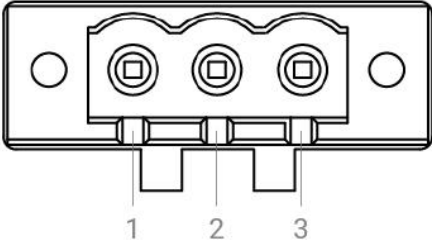
	Pin	Definition
	1	GND
	2	Chassis/Earth GND
3	12~24V VDC Input	

3-Pin terminal power pinout

5-Pin COM Terminal Block

The serial port supports RS-232, RS-422, and RS-485 configurations by way of a 5-pin terminal block connector (Mating part: Dinkle 0221-2005 or equivalent). The mode can be selected from within the operating system using available configuration tools. See documentation for details.

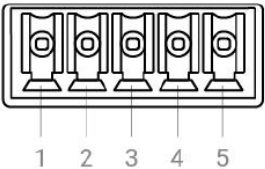
	Pin	RS-232	RS-422	RS-485
	1	GND	GND	GND
	2	NC	TX-	TX-/RX-
	3	NC	RX-	NC
	4	RX	TX+	TX+/RX+
	5	TX	RX+	NC

COM terminal pinout

LAN1 - CM4 Output

The CM4 LAN Port on Foundation 100 Series supports up to 1Gbps link speeds over standard shielded CAT5e or CAT6 cables. The connector is the industry standard RJ45 connector. The LAN link state is shown by the two LEDs enclosed in the port. Activity is also indicated by the LANI LED on the side of the system. The default configuration is included below, but the behavior can be customized using the CM4 boot configuration file.

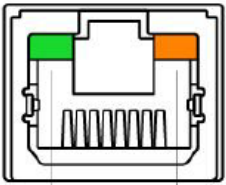
	Speed/Act State	Speed State	Function
	Off	Off	LAN link is not established
	Green (Flash for Activity)	Off	10 Mb/s data rate
	Green (Flash for Activity)	Orange	100 Mb/s data rate
	Off	Orange (Slow Blink)	1000 Mb/s data rate

LAN activity light description

LAN2 – Realtek RTL8153B

The second LAN Port on Foundation 100 Series supports up to 1Gbps link speeds over standard shielded CAT5e or CAT6 cables. The connector is the industry standard RJ45 connector. The LAN link state is shown by the two LEDs enclosed in the port. The description is included below. Activity is also indicated by the LAN2 LED on the side of the system.

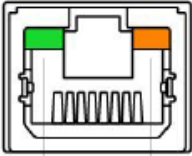

Speed/Act State	Speed/Act State	Function
Off	Off	LAN link is not established
Green (Flash off for Activity)	Green (Flash on for activity) / Orange	10 Mb/s data rate
Green (Flash on for Activity)	Green (Flash on for Activity) / Orange	100 Mb/s data rate
Green (Flash off for Activity)	Green (Flash on for Activity) / Orange	1000 Mb/s data rate

LAN activity light description

Power Management

Protection Circuitry

These DC levels specified are the absolute max values for the pins for function and safety of the system. The protection circuitry allows for brief transient voltages above these levels without the system turning off or being damaged. A transient voltage suppressor on the power input allows momentary excursions above stated limits.

Parameter	Value
Nominal operating voltage (Rated DC value of input)	12~24V
Undervoltage protection trip DC level (system turns off)	6.5V
Maximum safe DC voltage (system not damaged)	27V

EMC Results

Summary of EN 55032 / EN 55035 / EN 60601-1

The Foundation 100 Series platform complies with the EN 55032:2015 standards for radiated and conducted emissions limits. The unit is compliant with EN 55035:2016 and tailored by EN 60601-1-2 for ESD, radiated immunity, magnetic immunity, electrical fast transient (EFT) AC power line, dips/interrupts and EFT signal line immunity based on performance criteria in Tables 4, 5, 6, 7, 8, and 9.

ESD Immunity Data

ESD immunity tests were performed following EN 55035 in accordance with EN 61000-4-2 and EN 60601-1-2 in accordance with EN 61000-4-2.

The unit does not exhibit susceptibility to 4-kV and 6-kV contact/8-kV air and 8kV contact/15kV air discharges applied singly or repetitively and directly or indirectly. The relative humidity during unit testing was measured to be between 30% and 60%. The Foundation 100 Series platform was unaffected during testing.

Radiated Immunity Data

Radiated immunity tests were performed following EN 55035 in accordance with EN 61000-4-3 and EN 60601-1-2 in accordance with EN 61000-4-3.

The system does not exhibit susceptibility to 10 V/m radiated electric fields, amplitude modulated at 1000 Hz, 80%, from 80 MHz to 6 GHz. Frequencies listed are samples and spots. The Foundation 100 Series platform was unaffected during testing.

The system does not exhibit susceptibility to radiated electric fields, in accordance with EN 61000-4-3 Table 9. The Foundation 100 Series platform was unaffected during testing.

Magnetic Immunity Data

Magnetic immunity tests were performed following EN 60601-1-2 in accordance with EN 61000-4-8.

The system does not exhibit susceptibility to radiated magnetic fields of 30 A/m at 50/60Hz. The Foundation 100 Series platform was unaffected during testing.

Electrical Fast Transient Immunity Data

Electrical fast transient immunity tests were performed following EN 55035 in accordance with EN 61000-4-4 and EN 60601-1-2 in accordance with EN 61000-4-4.

The system does not exhibit susceptibility to 1-kV/2-kV electrical fast transients, delivered in 5-kHz bursts to power lines. "A" result = No effect on EUT.

The system does not exhibit susceptibility to 0.5-kV/1-kV electrical fast transients, delivered in 5-kHz bursts to signal lines. The Foundation 100 Series platform was unaffected during testing.

Dips/Interrupts Immunity Data

Dips/interrupts immunity tests were performed following EN 55035 and EN 60601-1-2 in accordance with EN 61000-4-11.

The system does not exhibit susceptibility. The Foundation 100 Series platform was unaffected during testing.

Safe Use and Installation Instructions

1. Install the device securely. Be careful handling the device to prevent injury and do not drop.
2. Wall or ceiling mounting the device requires use of a mounting plate or bracket. The plate or bracket must be of metal construction and have a minimum thickness of 1mm.
3. Use M4x0.5mm Flat Head screws to attach mounting plate or mounting brackets to threaded holes on bottom or rear of chassis. Screws should be a minimum length of 4mm. Add 1mm of screw length for every mm of additional thickness of plate or bracket beyond 1.5mm.
4. Ambient operating temperature must be between 0 °C to 60 °C with a non-condensing relative humidity of 10-90%.
5. The device can be stored at temperatures between -10 °C to 85 °C.
6. Keep the device away from liquids and flammable materials.
7. Do not clean the device with liquids. The chassis can be cleaned with a cloth.
8. Allow at least 2 inches of space around all sides of the device for proper cooling. It is recommended to mount the device such that the metal side plates are vertical to allow air to rise unobstructed. Alternative orientations may result in reduced operational temperature range.
9. This device is intended for indoor operation only.
10. Use UL Listed external power supply with rated output 8-24Vdc
11. Install the device only with shielded network cables.
12. Only use SAE approved cables for automotive installation.
13. The installer should be experienced in aftermarket installation and familiar with general practices for installing electronics devices in vehicles.
14. The device should not be installed in the driver's area of a vehicle.
15. The device should be mounted in accordance with accepted aftermarket practices and materials for vehicle installation.
16. Only use UL Listed connectors for power and serial.
17. Service and repair of the device must be done by qualified service personnel. This includes, but is not limited to, replacement of the CMOS battery. Replacement CMOS battery must be of the same type as the original.
18. Proper disposal of CMOS battery must comply with local governance.

Warning

There is danger of explosion if the CMOS battery is replaced incorrectly. Disposal of battery into fire or a hot oven, or mechanically crushing or cutting of a battery can result in an explosion.



Foundation 100 Series Product Manual

ISAAC is developed by Smart Monkeys, Inc.

Information in this document is subject to change without notice. Smart Monkeys, Inc. reserves the right to change or improve its products and to make changes in the content without obligation to notify any person or organization of such changes or improvements. Visit the ISAAC Web site (www.isaacplatform.com) for current updates and supplemental information concerning the use and operation of this and other ISAAC products.

ISAAC and the ISAAC “3 layer” logo and design are registered trademarks of Smart Monkeys, Inc. All other marks and names mentioned herein may be trademarks of their respective companies.

© Smart Monkeys, inc. All right reserved.