

# OPTI-GARD

HIGH-PERFORMANCE REVERSE ACTING RUPTURE DISC

**Versatile, single disc solution suitable for a wide range of process conditions. Using the Opti-Gard can reduce stock holdings by up to 65%.**

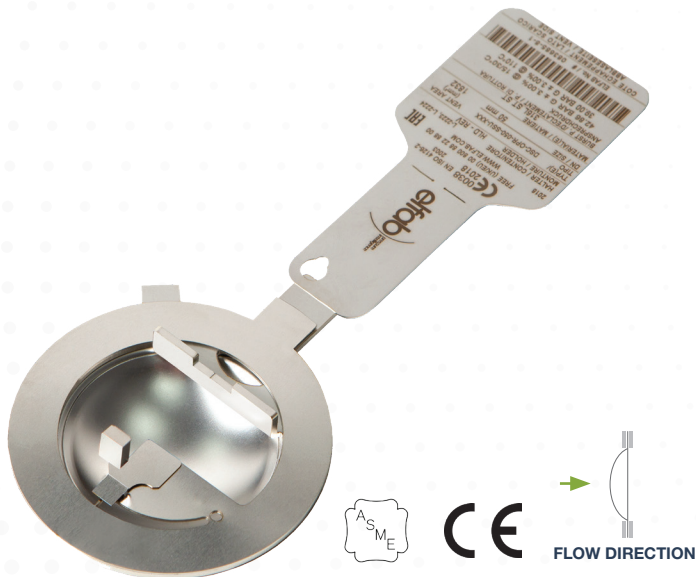

The high-performance Opti-Gard acts as a single disc solution across a complete line of sizes, materials, burst pressures and process conditions. Performing equally well with liquid, gas or vapour, Opti-Gard is the ideal multi-purpose pressure relief solution. It is non-fragmenting and can be used alone or in combination with a safety valve.

Opti-Gard features a smooth surface finish and can be supplied with an optional fluoropolymer liner on the process and/or vacuum side. It withstands full vacuum and high levels of back pressure without additional vacuum support to ensure the maximum free-flow area on burst.

When installed as part of our stock rationalisation programme, Opti-Gard can reduce stock holdings by up to 65%. This offers significant cost savings with reduced variance in inventory and installation, without affecting quality.

<b>Size</b>	1" - 24"
<b>Burst Pressure</b>	5 - 1,015 psig
<b>K<sub>R</sub> Value (K<sub>RGL</sub>)</b>	1.74
<b>Operating Ratio</b>	95%
<b>Performance Tolerance</b>	+/- 3%
<b>Manufacturing Range</b>	0%

**Let us help you with all your pressure relief questions.**

**US office** | Broken Arrow  
+1 (918) 258 5626 | info@osecoelfab.com

**UK office** | North Shields  
+44 (0)191 293 1234 | uksales@osecoelfab.com

[osecoelfab.com](http://osecoelfab.com)





Size range	1"-24" (25-600mm)
Burst pressure range	5 psig to 1015 psig (0.35 barg to 70 barg)
Temperature range	-328°F to 1112°F (-200°C to 600°C)
Standard materials	Hastelloy® C (others available on request)
K <sub>R</sub> Value	1.74
Max. Operating Ratio	95% of minimum burst pressure (92% of nominal burst pressure)
Performance Tolerance	+/-3%
Manufacturing Range	0%
Fragmentation	Non-fragmenting design
Vacuum Service	Withstands full vacuum (14.7 psi) without separate vacuum support
Fluid compatibility	Gas service, liquid service and two-phase service
Torque requirements	Not torque sensitive
Cycling or static service	Cycling service: Tested to over 100,000 pressure/vacuum cycles
Protective linings	Fluoropolymer liners available on vent and process sides
Relief Valve Isolation	Suitable for safety relief valve isolation
Disc Surface Finish	Smooth surface on the process side to minimize product build-up
Design Standards	Designed to meet ISO 4126-2:2019 and PED 2014/68/EU

## Certifications

ASME UD  
CE  
SIL

## Related Products

### Sensors

Flo-Tel  
Flo-Tel XD

### HOLDERS

Reverse holders

### Rupture Discs

Opti-Gard (High-Strength Magnet)  
Opti-Gard SoLo  
Opti-Gard Ferrule

# Burst Pressure Ranges

Opti-Gard Min/Max Burst Pressure @ 15-30°C (59-86°F)



SIZE		MATERIAL	MIN barg (psig)	MAX barg (psig)
DN (mm)	inches			
25	1	Hastelloy C 316 Stainless Steel / Inconel Nickel / Monel	3.5 (50)	70 (1015) 70 (1015) 55 (797)
40	1.5	Hastelloy C 316 Stainless Steel / Inconel Nickel / Monel	1.9 (27)	70 (1015) 70 (1015) 55 (797)
50	2	Hastelloy C 316 Stainless Steel / Inconel Nickel / Monel	0.9 (13) 1.0 (14) 1.0 (14)	60 (870) 60 (870) 45 (652)
65	2.5	Hastelloy C 316 Stainless Steel / Inconel Nickel / Monel	0.9 (13) 1.0 (14) 1.0 (14)	60 (870) 60 (870) 45 (652)
80	3	Hastelloy C 316 Stainless Steel / Inconel Nickel / Monel	0.5 (7)	50 (725) 50 (725) 38 (551)
100	4	Hastelloy C 316 Stainless Steel / Inconel Nickel / Monel	0.35 (5)	50 (725) 50 (725) 38 (551)
150	6	Hastelloy C 316 Stainless Steel / Inconel Nickel / Monel	0.7 (10)	40 (580) 40 (580) 30 (435)
200	8	Hastelloy C 316 Stainless Steel / Inconel Nickel / Monel	0.6 (8.5)	30 (435) 30 (435) 23 (334)
250	10	Hastelloy C 316 Stainless Steel / Inconel Nickel / Monel	0.5 (7)	20 (290) 20 (290) 15 (217)
300	12	Hastelloy C 316 Stainless Steel / Inconel Nickel / Monel	0.5 (7)	15 (217) 15 (217) 11 (159)
350	14	Hastelloy C 316 Stainless Steel / Inconel Nickel / Monel	0.4 (5.7)	12 (174) 12 (174) 9.5 (137)
400	16	Hastelloy C 316 Stainless Steel / Inconel Nickel / Monel	0.4 (5.7)	6 (87) 6 (87) 4.5 (65)
450	18	Hastelloy C 316 Stainless Steel / Inconel Nickel / Monel	0.4 (5.7)	6 (87) 6 (87) 4.5 (65)
500	20	Hastelloy C 316 Stainless Steel / Inconel Nickel / Monel	0.4 (5.7)	6 (87) 6 (87) 4.5 (65)
600	24	Hastelloy C 316 Stainless Steel / Inconel Nickel / Monel	0.4 (5.7)	6 (87) 6 (87) 4.5 (65)

## Free Flow Area / Minimum Net Flow Area (MNFA)



NOMINAL BORE		MNFA with no vacuum support (XXX)	
DN (mm)	inches	mm <sup>2</sup>	Sq. Inch
25	1	494	0.766
40	1.5	1,065	1.651
50	2	1,799	2.789
65	2.5	2,657	4.119
80	3	4,336	6.722
100	4	7,047	10.923
150	6	15,046	23.322
200	8	28,625	44.37
250	10	42,095	65.248
300	12	61,294	95.006
350	14	81,278	125.982
400	16	110,674	171.545
450	18	137,932	213.795
500	20	167,571	259.735
600	24	240,048	372.075

## Burst Tolerance

+/-2 psig ≤ 65 psig  
+/-3% > 65 psig

+/-0.14 barg ≤ 4.48 barg  
+/-3% > 4.48 barg

## K<sub>R</sub> Value (Frictional Loss Factor)

K <sub>R</sub>	Opti-Gard
K <sub>RGL</sub>	1.74

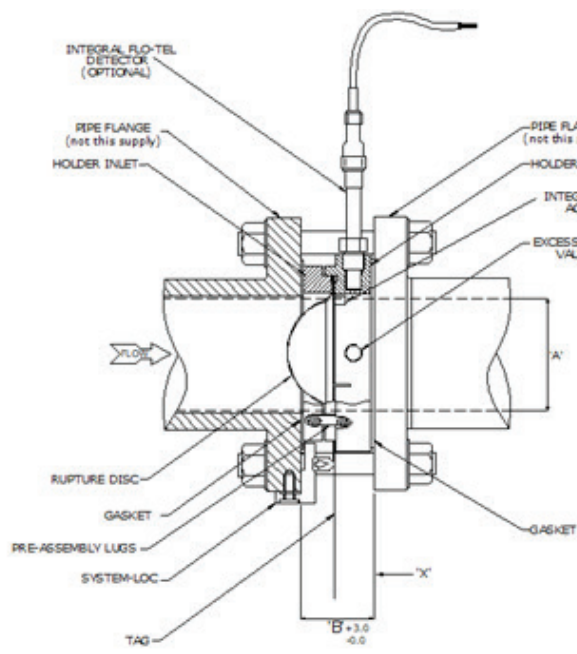

Without Dome Protection

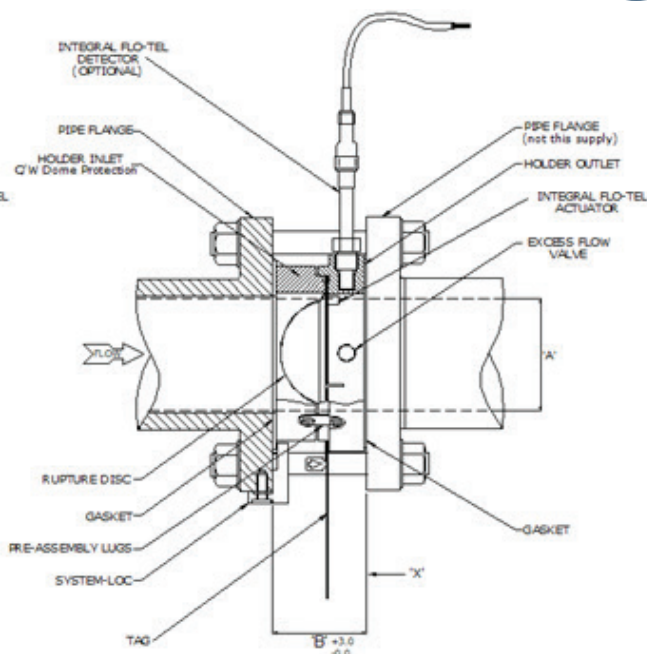

With Dome Protection

NOMINAL BORE (A)		FACE-TO-FACE (B)	
DN (mm)	inches	With dome protection (mm)	No dome protection (mm)
25	1	40.4 (Std)	-
40	1.5	42.4 (Std)	-
50	2	44.4 (Std)	-
65	2.5	50 (Std)	-
80	3	55 (Std)	-
100	4	58 (Std)	-
150	6	74.5 (Std)	-
200	8	90.5	51.5 (Std)
250	10	105.5	51.5 (Std)
300	12	120.5	51.5 (Std)
350	14	145	51 (Std)
400	16	166	51 (Std)
450	18	182	51 (Std)
500	20	201	51 (Std)
600	24	238	51 (Std)

FLANGE SPECIFICATIONS	
EN 1092-1 PN DESIGNATED	BS EN 1759-1 ANSI DESIGNATED
PN 6	ANSI 150
PN 10	ANSI 300
PN 16	ANSI 600
PN 20	ANSI 900
PN 25	ANSI 1500
PN 40	ANSI 2500
PN 50	-
PN 63	-
PN 100	-

Face-to-face dimensions account for the disc and holder assembly only. They do not account for gasket thickness.