

MILLI-GARD

ULTRA LOW PRESSURE REVERSE ACTING RUPTURE DISC

Composite reverse acting disc for gas or vapour applications operating at very low pressures



Milli-Gard's composite construction is specifically designed for accuracy at ultra-low burst pressures.

Unlike other manufacturers' designs, it can act as a single disc solution for either positive pressure or vacuum protection, depending on the application and method of installation.

Milli-Gard offers non-fragmenting opening. All Milli-Gard discs are fitted with a Flo-Tel actuator as standard. As Flo-Tel is non-invasive to the process, it offers accurate functionality even at the lowest end of the burst pressure range.

Install Milli-Gard in our reverse acting disc holder, which is suitable for use within flat and raised-face flanges.

Size	2" - 12"
Burst Pressure	0.044 psig - 7.25 psig
Operating Ratio	60%
Performance Tolerance	+/- 25%
Manufacturing Range	0%

Let us help you with all your pressure relief questions.

US office | Broken Arrow
+1 (918) 258 5626 | info@osecoelfab.com

UK office | North Shields
+44 (0)191 293 1234 | uksales@osecoelfab.com

osecoelfab.com





Size range	2"-12" (50-300mm)
Burst pressure range	0.044 psig to 7.25 psig (3 mbarg to 500 mbarg)
Temperature range	-40°F to 302°F (-40°C to 150°C)
Standard materials	316 Stainless Steel (others available on request)
Max. Operating Ratio	60% of minimum burst pressure (45% of nominal burst pressure)
Performance Tolerance	+/-25%
Manufacturing Range	0%
Fragmentation	Non-fragmenting design
Vacuum Service	Withstands full vacuum (14.7 psi) without separate vacuum support
Fluid compatibility	Gas service, vapour service
Torque requirements	Not torque sensitive
Cycling or static service	Cycling service
Relief Valve Isolation	Suitable for safety relief valve isolation
Design Standards	Designed to meet ISO 4126-2:2019

Certifications

SIL

Related Products

Sensors

Flo-Tel
Flo-Tel XD

Accessories

Test-Tel
System Loc

Rupture Discs

Opti-Gard
Opti-Gard SoLo

HOLDERS

Reverse holders

Burst Pressure Ranges

Milli-Gard Min/Max Burst Pressure @ 15-30°C (59-86°F)



SIZE		MATERIAL	MIN mbarg (psig)	MAX mbarg (psig)
DN (mm)	inches			
50	2	316 Stainless Steel	50 (0.72)	500 (7.25)
80	3	316 Stainless Steel	25 (0.36)	400 (5.80)
100	4	316 Stainless Steel	18 (0.26)	250 (3.63)
150	6	316 Stainless Steel	10 (0.15)	200 (2.90)
200	8	316 Stainless Steel	5 (0.07)	150 (2.18)
250	10	316 Stainless Steel	5 (0.07)	150 (2.18)
300	12	316 Stainless Steel	3 (0.044)	150 (2.18)



Free Flow Area / Minimum Net Flow Area (MNFA)

NOMINAL BORE		MNFA	
DN (mm)	inches	mm ²	Sq. Inch
50	2	1,023	1.59
80	3	2,665	4.15
100	4	4,264	6.64
150	6	9,230	14.38
200	8	16,802	26.18
250	10	26,955	42.01
300	12	38,961	60.72

Burst Tolerance

+/- 3.5 mbarg < 14 mbarg
+/-25% > 14 mbarg

+/- 0.05 psig < 0.2 psig
+/-25% > 0.2 psig

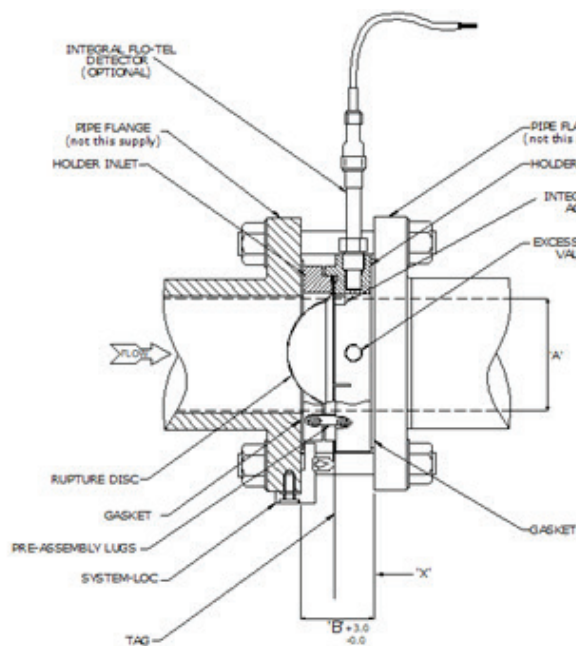

Without Dome Protection

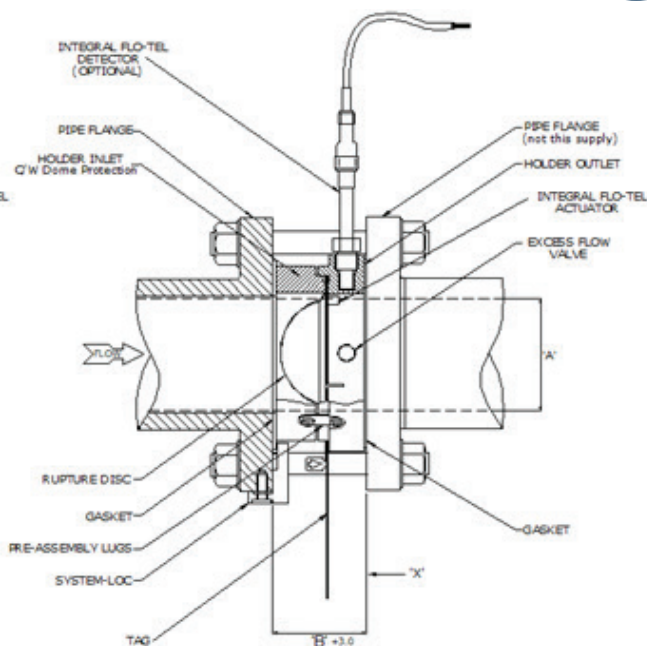

With Dome Protection

NOMINAL BORE (A)		FACE-TO-FACE (B)	
DN (mm)	inches	With dome protection (mm)	No dome protection (mm)
50	2	44.4 (Std)	-
65	2.5	50 (Std)	-
80	3	55 (Std)	-
100	4	58 (Std)	-
150	6	74.5 (Std)	-
200	8	90.5	51.5 (Std)
250	10	105.5	51.5 (Std)
300	12	120.5	51.5 (Std)

Face-to-face dimensions account for the disc and holder assembly only. They do not account for gasket thickness.

FLANGE SPECIFICATIONS	
EN 1092-1 PN DESIGNATED	BS EN 1759-1 ANSI DESIGNATED
PN 6	ANSI 150
PN 10	ANSI 300
PN 16	ANSI 600
PN 20	ANSI 900
PN 25	ANSI 1500
PN 40	ANSI 2500
PN 50	-
PN 63	-
PN 100	-